

SHUTON

HIGH DYNAMICS INSIDE

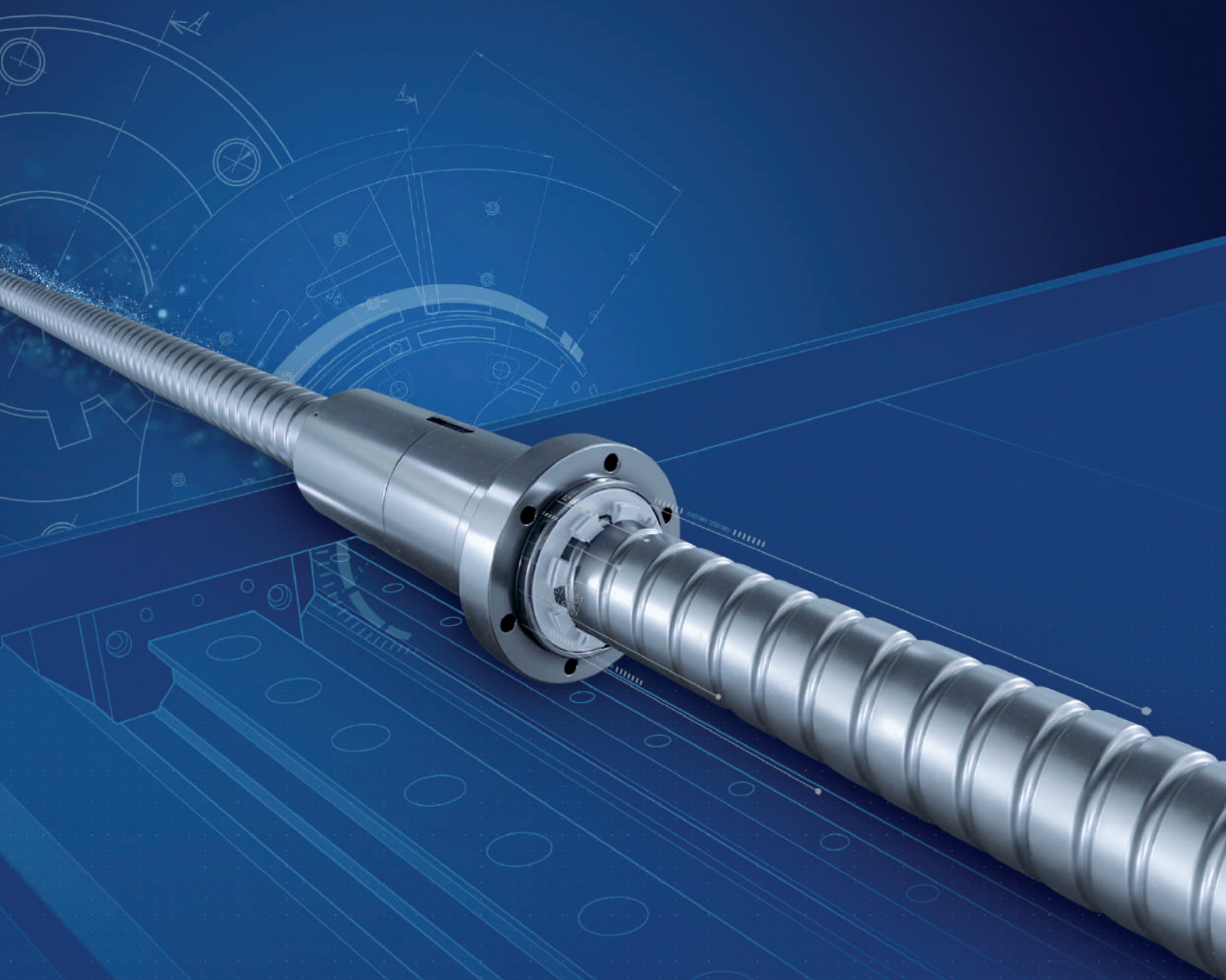

NADELLA
GROUP

SHUTON has verified the accuracy of all the data contained in this catalogue. However, it does not accept liability for any possible incorrect or incomplete data.

Due to the constant development of products, SHUTON reserves the right to modify any information or data in this catalogue without notice.

Publisher:

SHUTON, S.A.

Polígono Industrial Goiain

01170 Legutiano (Álava)

SPAIN

<http://www.shuton.com>

e-mail: shuton@shuton.com

Version EN20

All rights reserved.

Reproduction in full or in part, without SHUTON authorisation, is prohibited.



This catalogue contains the tables of dimensions, loads and nut rigidities,
according to DIN 69051 and ISO 3408 standards,
of precision ball screws manufactured by SHUTON.



INDEX

Company introduction	06
Precision Ball screws	10
Types of Nut	10
Types of ball recirculation system	11
Ball screw Technology	12
SHUTON COMPLEX	13
TD Complex preloaded double nut	15
TUC Complex preloaded ultracompact nut	16
SHUTON PRIME	17
TC PRIME Preloaded Compact nut	18
TD PRIME Preloaded Double nut	19
SHUTON HIGH LOADS	20
TS HIGH LOADS Single nut	20
SHUTON ATR	26
TS ATR Single nut	26
Customised Solutions	28
Engineering service	30
Technical forms and SHUTON calculation programme	30
Quick Selection of a ball screw	33
Reference definition (nomenclature)	36
Ball screws according fastening method	38

Technical description of ball screws	39
Dynamic load and ball screw life expectancy	39
Static load and ball screw force bearing limits	43
Ball screw axial rigidity	45
The importance of axial rigidity in ball screws	49
Ball screw rotation speed limit	50
DN limit	50
Critical rotation speed	51
Ball screw lubrication	52
Lubrication types. Viscosity, load and speed	52
Grease lubrication	53
Oil lubrication	53
Air-oil mix lubrication	54
Comparison and summary: Grease, Oil, Air-Oil	55
Temperature. Thermal expansion. Pretensioning	56
Ball screw refrigeration	57
Deflection or radial deformation due to shaft weight. Intermediate supports	58
Ball screw noise	60
Motor torque, acceleration, system inertia	61
Assembly examples. Rotating shaft and rotating nut. Pretensioned shaft	62
Ball screw acceptance conditions and tests	64
Tables of Load and Dimensions	86
COMPLEX	86
TD Double Nut (1 start), TUC Ultracompact Nut	90
TD Double Nut (2 starts)	132
TUC Most common Ultracompact nut cases	146
PRIME	148
TD Double Nut, TC Compact Nut	152
HIGH LOADS	164
TS Single Nut	168
ATR	200
TS Single Nut	204
SHUTON location and contacts	242

Major SHUTON markets in:

AMERICA

Brazil
Canada
United States

EUROPE

Austria
Czech Republic
France
Germany
Italy
Slovaquia
Spain
Switzerland
Turkey
United Kingdom

ASIA

China
India
Japan
South Korea

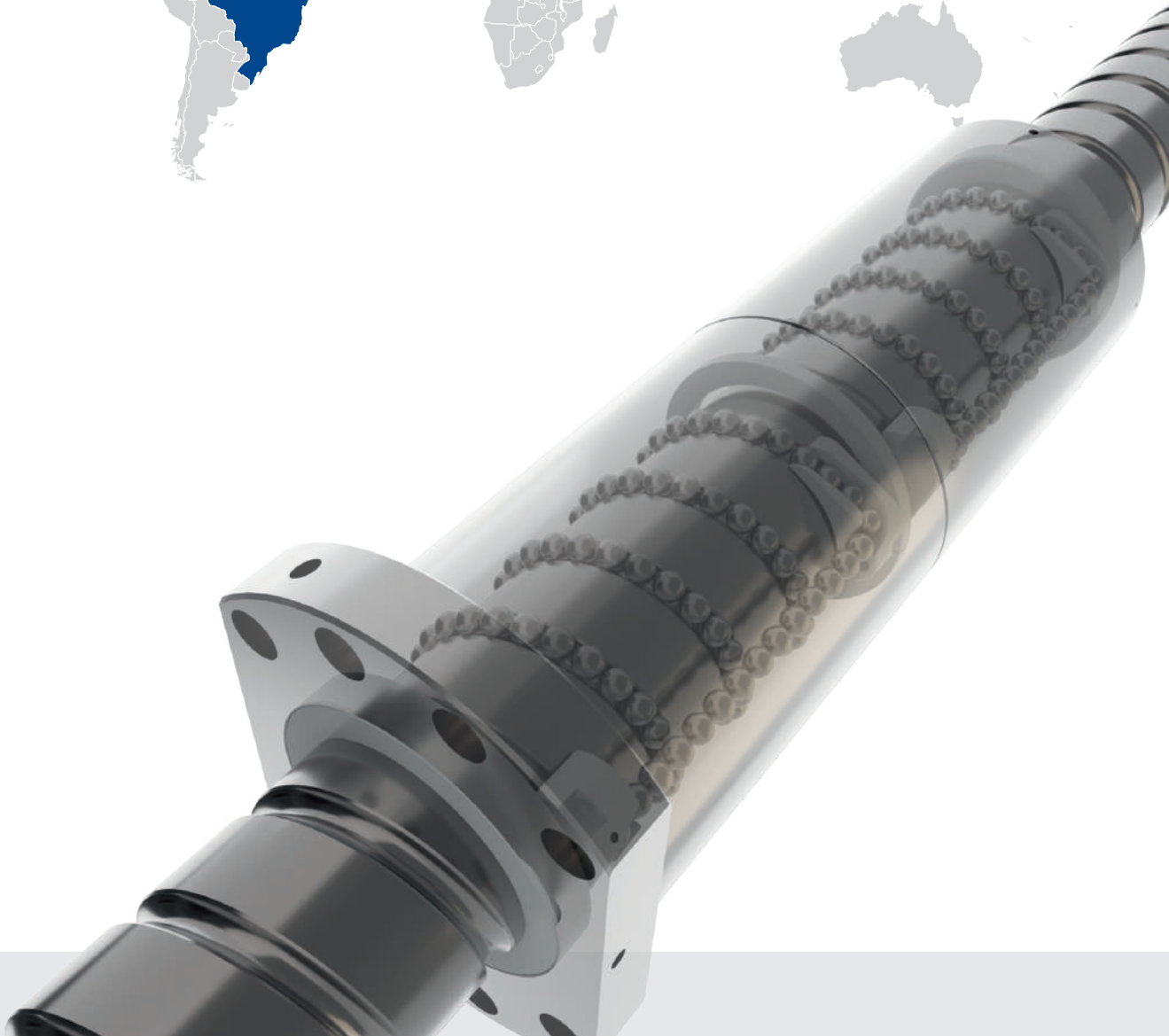
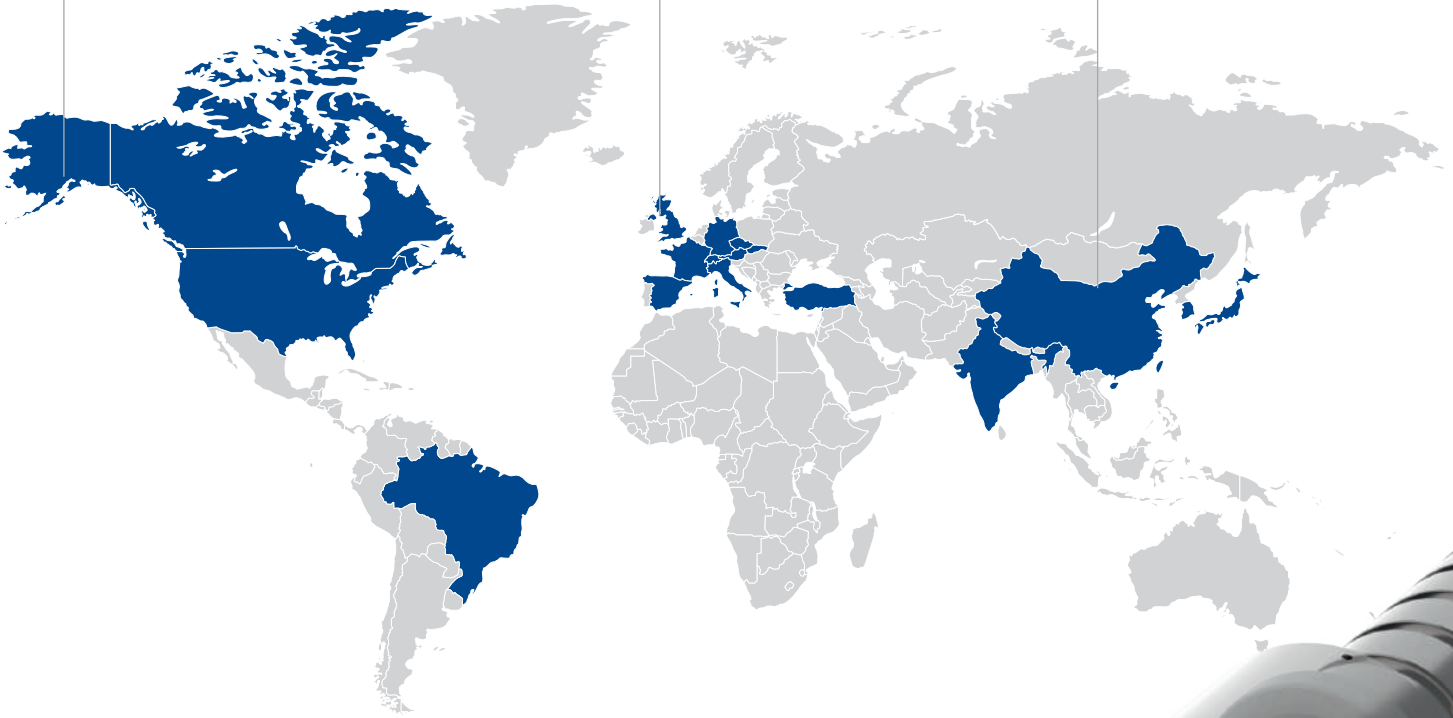

At SHUTON we are glad to introduce to you our product catalogue, containing our latest developments in High-performance ball screws. The new catalogue is a product of ongoing research in our Technology Centre, collaboration with selected technological centres and challenges by the most demanding requirements of our customers.

SHUTON is a leading company in the manufacture of high precision ball screws located in the Basque Country, central and leading area in the machine tool industry in the north of Spain and throughout Europe.

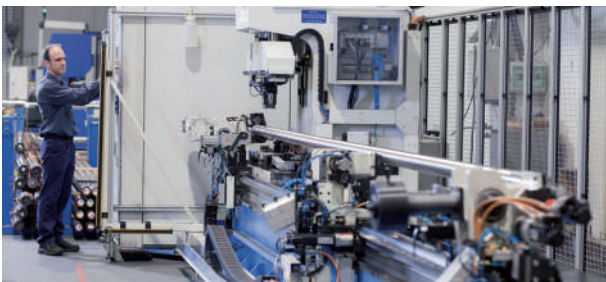
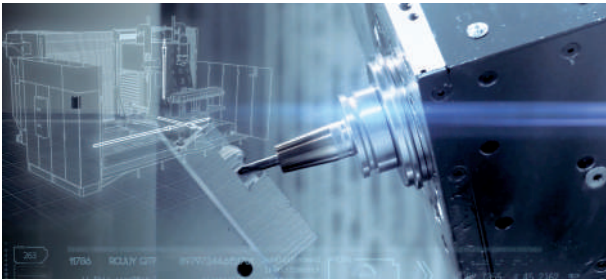

SHUTON has been a part of the Nadella Group since 2020, and with more than 45 years of experience in the development and manufacture of high precision ball screws, our presence in the most advanced machine construction markets, and our close relationship with leading manufacturers facilitates the optimization of our products in order to offer the most efficient results for the most demanding applications.

We are an active and experienced team, of innovative mentality and great capacity for growth and improvement, committed to offer the most innovative and appropriate products and services that best suit the needs of our customers.

Excellence is our key principle that leads us to be present today and in the future as key collaborators and best partners of our customers.





HIGHER PERFORMANCE

Improvement in ball screw acceleration and feed speeds for a better performance for longer duration in extreme applications.



HIGHER RIGIDITY

Efficient rigidity oriented at enhancing the machining quality of the parts, optimizing the natural frequency of the system and improving motor parameters K_v and K_p , and the jerk.



HIGHER DYNAMICS

Improvement of accelerations and feed speeds of the drive, keeping optimum temperature and noise levels.



Engineered by SHUTON



HIGHER DURABILITY

Parallel improvements in materials, treatment and manufacturing processes contribute to an additional increase of the ball screw life.



INCREASED UPTIME

Improvement of ball screw life for increasing the machine uptime.

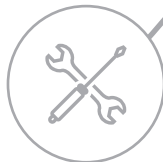

LESS MAINTENANCE

Improvement of ball screw performance and life for a reduction of life-cycle costing (LCC).

HIGH DYNAMICS INSIDE

Xtrem Dynamics redefines **SHUTON**'s philosophy in the search of technologies and materials with the aim of increasing the rigidity of the Ball screws, to improve the dynamics and therefore the efficiency of the machine, resulting in productivity for longer.

In line with this Xtrem Dynamics philosophy and with the aim of obtaining the best results in the most demanding applications, SHUTON has developed different technologies adapted to the different application areas:

SHUTON
COMPLEX

SHUTON
HIGH LOADS

SHUTON
PRIME

SHUTON
ATR

SHUTON **COMPLEX**

High precision ball screws for high dynamics machine tools with efficient rigidity requirements and extreme duty cycles. Oriented to improve machining times in productively demanding sectors such as automotive, aeronautics, die mold processing machines, etc.

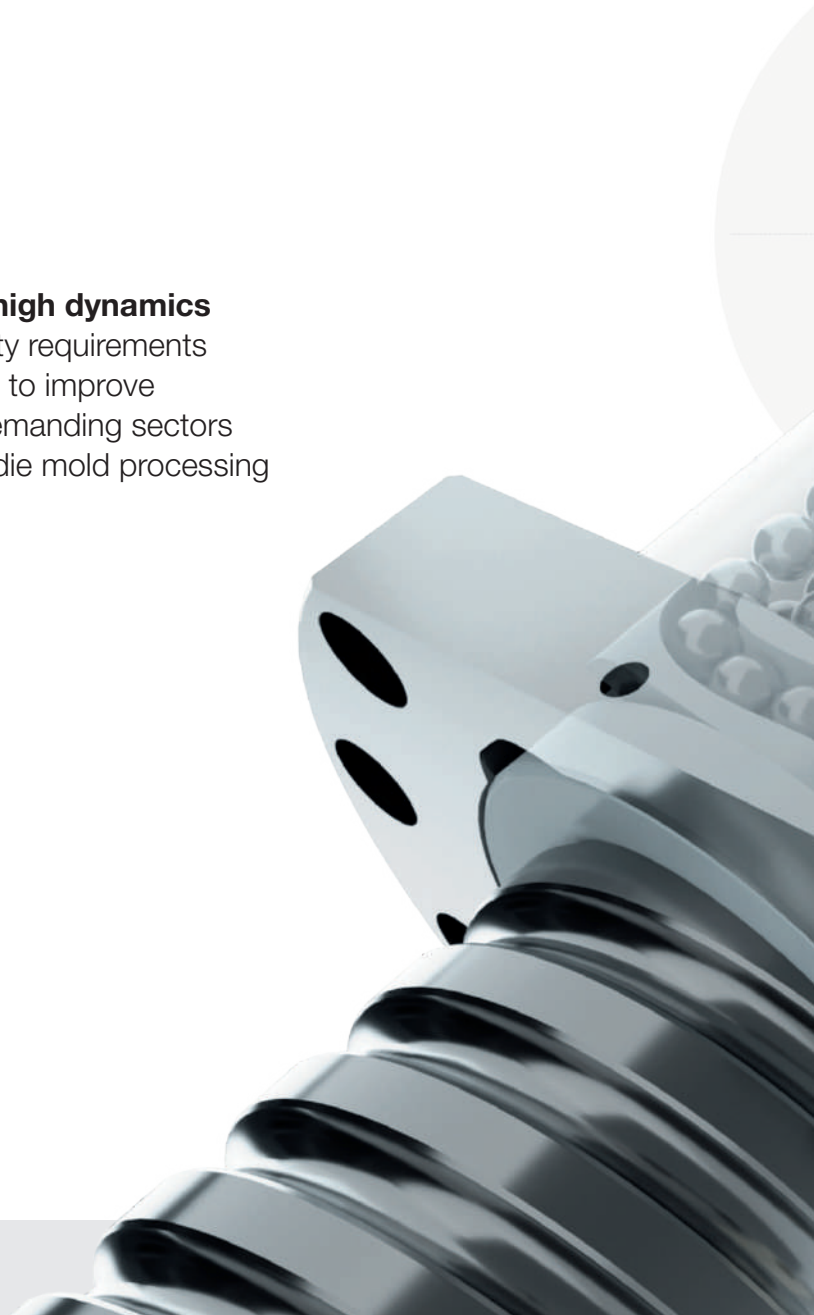



SHUTON COMPLEX

SHUTON COMPLEX

U-type recirculation system

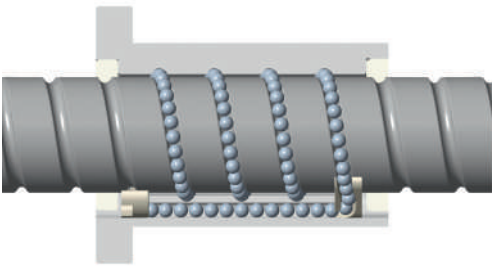

B-type recirculation system

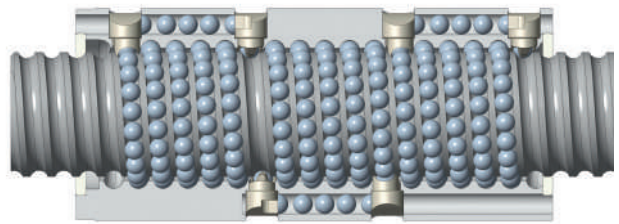

Types of COMPLEX nuts depending on application:

Technology	Sectors	Features	Preload	Nut type	Recirc.	Diameter	Lead	Ball size	Application
COMPLEX	Machine tool (high speed 5 axis, large size and combined machines tools, die mold processing machines, aeronautics and automotive work pieces and other applications with highly demanding conditions.)	High dynamics Efficient rigidity (optimization of rigidity-torque relation) DN up to 210.000. => For Highly demanding duty cycles improvement of machining times	YES	TD Double Nut (1 start)	U	25-120	10-80	5-12	High dynamic applications, Average load requirement
					B	50-160	12,7-25	9-19	High dynamic applications, Higher load requirement
				TD Double Nut (2 start)	U	32-120	20-80	6-12	High dynamic applications, Higher load requirement, without nut length limitation
					B	63-140	25-32	9-12	High dynamic applications, Extra high load requirement, without nut length limitation
				TUC Ultracompact Nut (2start)	U	32-100	20-80	6-9	High dynamic applications, High load requirement, with nut length limitation
					B	63-100	25	9	High dynamic applications, Extra high load requirement, with nut length limitation

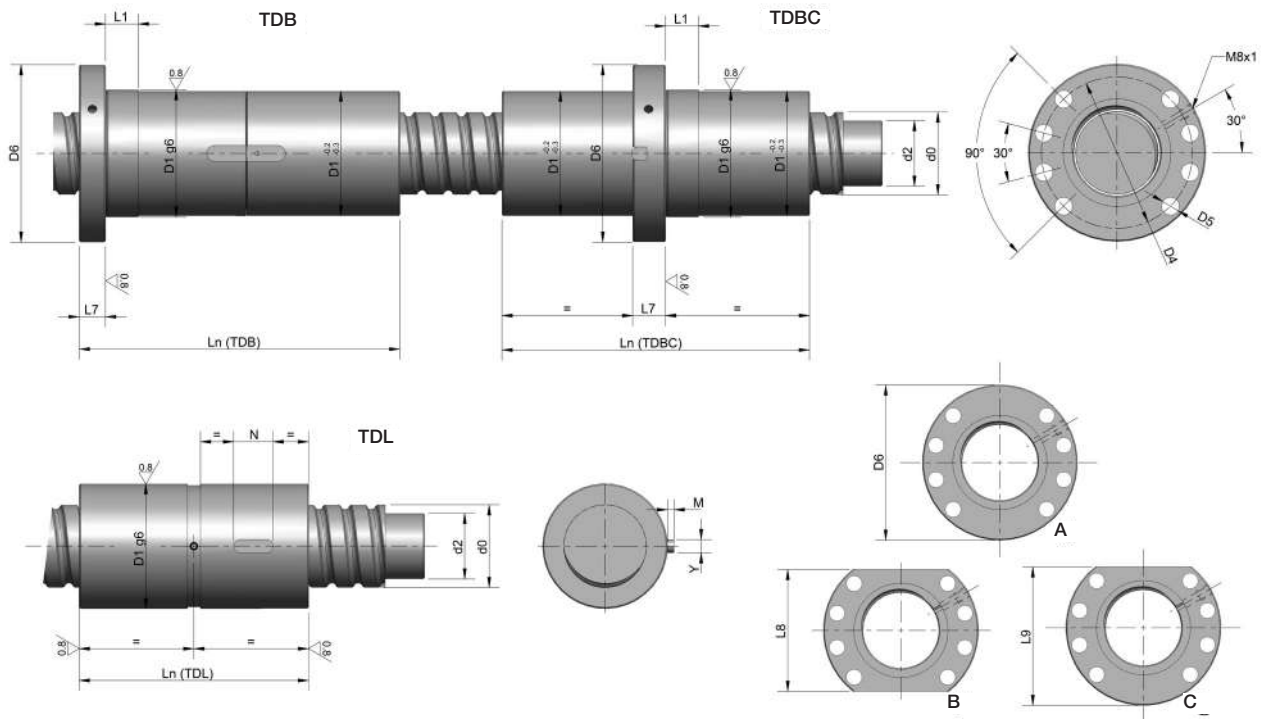
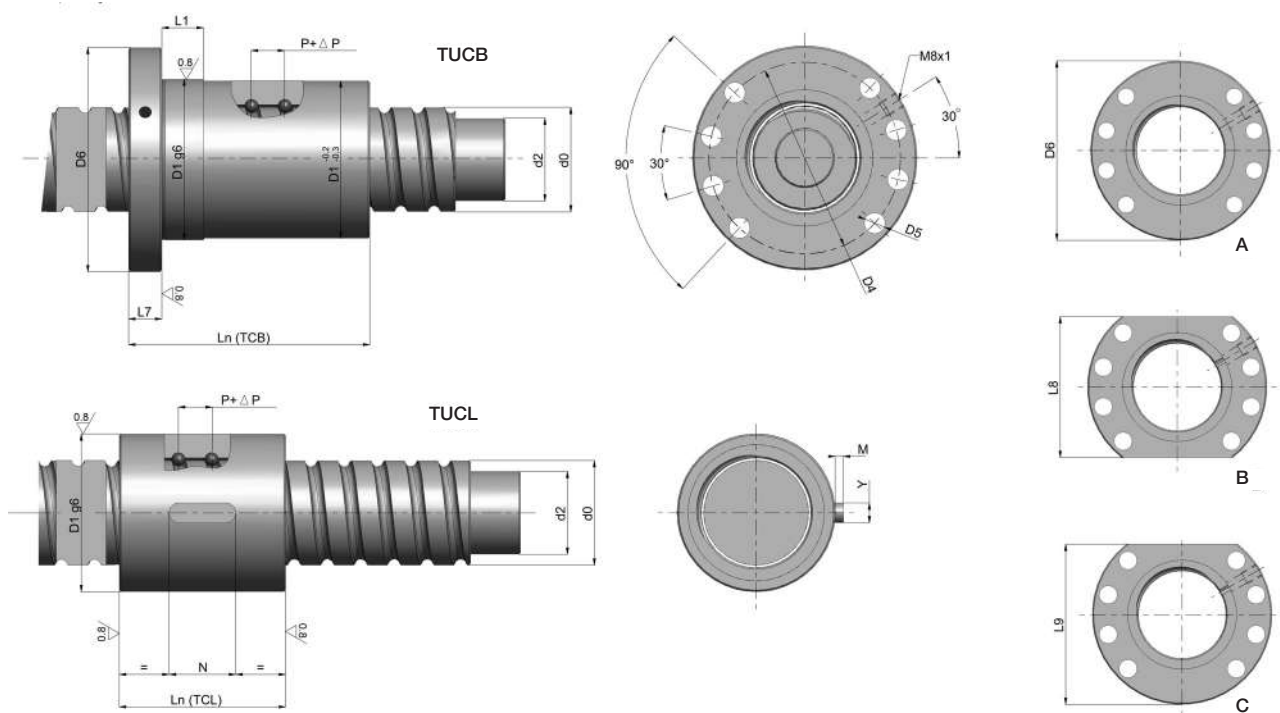
COMPLEX Double Nut

COMPLEX Ultracompact nut

COMPLEX, Double Nut (1start), Ultracompact Nut

Ball screw reference	Nominal diameter	Lead	Ball diameter	Root diameter	Circuits	Dynamic load capacity	Static load capacity	Rigidity of ball contact zone, with Fpr:10%Ca	Rigidity of nut, with Fpr:10%Ca
TDB Flanged double nut TDL Cylindrical double nut TDBC Centre flanged double nut TUCB Flanged Ultracompact nut TUCL Cylindrical Ultracompact nut	d_0	P_h	D_w	d_2	$i (I_e)$	$C_a (N)$	$C_{oa} (N)$	$R_{b/t,pr} (N/\mu m)$	$R_{nu} (N/\mu m)$
TD_-U 2510-5-2	25	10	4,762	21,7	2	17900	25900	670	650
TD_-U 2510-5-3	25	10	4,762	21,7	3	25500	42000	1040	1010
TD_-U 2510-5-4	25	10	4,762	21,7	4	32700	57200	1380	1340
TD_-U 2510-5-5	25	10	4,762	21,7	5	40100	73300	1730	1680
TD_-U 2512-5-2	25	12	4,762	21,7	2	17900	25800	670	650
TD_-U 2512-5-3	25	12	4,762	21,7	3	25400	41900	1040	1010
TD_-U 2512-5-4	25	12	4,762	21,7	4	32600	57000	1370	1330
TD_-U 2515-5-2	25	15	4,762	21,7	2	17700	25700	660	640
TD_-U 2515-5-3	25	15	4,762	21,7	3	25200	41600	1020	1000
TD_-U 2516-5-2	25	16	4,762	21,7	2	17700	25600	650	640
TD_-U 2516-5-3	25	16	4,762	21,7	3	25200	41500	1020	1000
TD_-U 2520-5-2	25	20	4,762	21,7	2	17900	26300	660	650
TD_-U 2525-5-2	25	25	4,762	21,7	2	17500	25900	640	630
TD_-U 3210-6-2	32	10	6,35	26,5	2	28900	42500	830	800
TD_-U 3210-6-3	32	10	6,35	26,5	3	41600	70300	1320	1260
TD_-U 3210-6-4	32	10	6,35	26,5	4	53600	96500	1770	1700
TD_-U 3210-6-5	32	10	6,35	26,5	5	65900	124300	2230	2140
TD_-U 3210-6-6	32	10	6,35	26,5	6	77300	150400	2630	2520
TD_-U 3212-6-2	32	12	6,35	26,5	2	28800	42400	830	800
TD_-U 3212-6-3	32	12	6,35	26,5	3	41500	70200	1310	1270
TD_-U 3212-6-4	32	12	6,35	26,5	4	53400	96300	1760	1700
TD_-U 3212-6-5	32	12	6,35	26,5	5	65700	124000	2220	2140
TD_-U 3212-6-6	32	12	6,35	26,5	6	77100	150100	2620	2530
TD_-U 3215-6-2	32	15	6,35	26,5	2	29400	43900	850	830
TD_-U 3215-6-3	32	15	6,35	26,5	3	41300	69900	1300	1260
TD_-U 3215-6-4	32	15	6,35	26,5	4	53800	97500	1780	1730
TD_-U 3216-6-2	32	16	6,35	26,5	2	29300	43800	850	820
TD_-U 3216-6-3	32	16	6,35	26,5	3	41200	69800	1300	1260
TD_-U 3216-6-4	32	16	6,35	26,5	4	53700	97400	1770	1730
TD_/TUC_-U 3220-6-2	32	20	6,35	26,5	2	29100	43500	830	820
TD_/TUC_-U 3220-6-3	32	20	6,35	26,5	3	40900	69300	1280	1250
TD_/TUC_-U 3225-6-2	32	25	6,35	26,5	2	28700	43100	820	800
TD_/TUC_-U 3225-6-3	32	25	6,35	26,5	3	41000	70300	1280	1260
TD_/TUC_-U 3232-6-2	32	32	6,35	26,5	2	28800	43900	820	810
TD_-U 4010-6-2	40	10	6,35	34,5	2	33800	56500	1060	1000
TD_-U 4010-6-3	40	10	6,35	34,5	3	48000	91400	1630	1530
TD_-U 4010-6-4	40	10	6,35	34,5	4	61600	124700	2190	2060
TD_-U 4010-6-5	40	10	6,35	34,5	5	74900	157900	2700	2540
TD_-U 4010-6-6	40	10	6,35	34,5	6	88400	192800	3230	3050
TD_-U 4010-6-7	40	10	6,35	34,5	7	101200	226100	3710	3510
TD_-U 4010-6-8	40	10	6,35	34,5	8	113700	259300	4170	3940

* C_a and C_{oa} : Modified static and dynamic load capacities, calculated according to DIN 69051/4 standard and ISO3408/5. See pages 39 and 43.

** $R_{b/t,pr}$: Rigidity of the balls contact zone for an external force 10% of C_a . See page 47. For a different preload force, multiply by $\sqrt[3]{F_{pr}/0,1 C_a}$

*** R_{nu} : Total rigidity of the complete nut. It must be multiplied by the factor $f_{a'}$, which depends on the manufacturing tolerance. See page 48.

Nut length 1 start	Nut length 2 starts	Nut dimensions										Grease quantity TD 'steel ball'	Grease quantity TUC 'steel ball'	Ball screw reference
		$D_{1, std}$	$D_{1, min}$	D_4	D_6	M	D_5	L_7	L_1	L_8	L_9			
TDB	TUC											$Q_{gr, real, TD}$ (cm^3)	$Q_{gr, real, TUC}$ (cm^3)	
89	--	50	(45)	65 (58)	80 (71)	M8	9	10	16	62 (55)	71 (63)	4,4 ~ 6,5	--	TD_U 2510-5-2
109	--	50	(45)	65 (58)	80 (71)	M8	9	10	16	62 (55)	71 (63)	5,2 ~ 7,8	--	TD_U 2510-5-3
129	--	50	(45)	65 (58)	80 (71)	M8	9	10	16	62 (55)	71 (63)	6,1 ~ 9,2	--	TD_U 2510-5-4
149	--	50	(45)	65 (58)	80 (71)	M8	9	10	16	62 (55)	71 (63)	7 ~ 10	--	TD_U 2510-5-5
97	--	50	(45)	65 (58)	80 (71)	M8	9	10	16	62 (55)	71 (63)	4,6 ~ 6,9	--	TD_U 2512-5-2
121	--	50	(45)	65 (58)	80 (71)	M8	9	10	16	62 (55)	71 (63)	5,6 ~ 8,4	--	TD_U 2512-5-3
145	--	50	(45)	65 (58)	80 (71)	M8	9	10	16	62 (55)	71 (63)	6,7 ~ 10	--	TD_U 2512-5-4
107	--	50	(45)	65 (58)	80 (71)	M8	9	14	16	62 (55)	71 (63)	4,8 ~ 7,2	--	TD_U 2515-5-2
137	--	50	(45)	65 (58)	80 (71)	M8	9	14	16	62 (55)	71 (63)	6,1 ~ 9,2	--	TD_U 2515-5-3
111	--	50	(45)	65 (58)	80 (71)	M8	9	14	16	62 (55)	71 (63)	5 ~ 7,5	--	TD_U 2516-5-2
139	--	50	(45)	65 (58)	80 (71)	M8	9	14	16	62 (55)	71 (63)	6,1 ~ 9,1	--	TD_U 2516-5-3
125	--	50	(45)	65 (58)	80 (71)	M8	9	14	16	62 (55)	71 (63)	5,4 ~ 8,1	--	TD_U 2520-5-2
141	--	50	(45)	65 (58)	80 (71)	M8	9	14	16	62 (55)	71 (63)	6 ~ 9	--	TD_U 2525-5-2
106	--	56		71	86	M8	9	14	20	65	75,5	8,5 ~ 13	--	TD_U 3210-6-2
126	--	56		71	86	M8	9	14	20	65	75,5	9,5 ~ 14	--	TD_U 3210-6-3
146	--	56		71	86	M8	9	14	20	65	75,5	11 ~ 16	--	TD_U 3210-6-4
166	--	56		71	86	M8	9	14	20	65	75,5	12 ~ 18	--	TD_U 3210-6-5
177	--	56		71	86	M8	9	14	20	65	75,5	12 ~ 18	--	TD_U 3210-6-6
108	--	56		71	86	M8	9	14	20	65	75,5	7,4 ~ 11	--	TD_U 3212-6-2
132	--	56		71	86	M8	9	14	20	65	75,5	8,6 ~ 13	--	TD_U 3212-6-3
156	--	56		71	86	M8	9	14	20	65	75,5	9,9 ~ 15	--	TD_U 3212-6-4
177	--	56		71	86	M8	9	14	20	65	75,5	11 ~ 16	--	TD_U 3212-6-5
204	--	56		71	86	M8	9	14	20	65	75,5	13 ~ 19	--	TD_U 3212-6-6
125	--	56		71	86	M8	9	14	20	65	75,5	7,7 ~ 12	--	TD_U 3215-6-2
155	--	56		71	86	M8	9	14	20	65	75,5	9,2 ~ 14	--	TD_U 3215-6-3
185	--	56		71	86	M8	9	14	20	65	75,5	11 ~ 16	--	TD_U 3215-6-4
130	--	56		71	86	M8	9	14	20	65	75,5	7,7 ~ 12	--	TD_U 3216-6-2
162	--	56		71	86	M8	9	14	20	65	75,5	9,3 ~ 14	--	TD_U 3216-6-3
194	--	56		71	86	M8	9	14	20	65	75,5	11 ~ 16	--	TD_U 3216-6-4
131	77	56		71	86	M8	9	14	20	65	75,5	6,6 ~ 9,9	4,9 ~ 7,3	TD_U/TUC_U 3220-6-2
171	97	56		71	86	M8	9	14	20	65	75,5	8,5 ~ 13	6 ~ 9,1	TD_U/TUC_U 3220-6-3
155	88	56		71	86	M8	9	14	20	65	75,5	6,8 ~ 10	5,1 ~ 7,6	TD_U/TUC_U 3225-6-2
201	111	56		71	86	M8	9	14	20	65	75,5	8,9 ~ 13	5,9 ~ 8,9	TD_U/TUC_U 3225-6-3
177	96	56		71	86	M8	9	14	20	65	75,5	7,2 ~ 11	4,3 ~ 6,5	TD_U/TUC_U 3232-6-2
107	--	63		78	93	M8	9	14	16	70	81,5	10 ~ 16	--	TD_U 4010-6-2
127	--	63		78	93	M8	9	14	16	70	81,5	12 ~ 18	--	TD_U 4010-6-3
147	--	63		78	93	M8	9	14	16	70	81,5	13 ~ 20	--	TD_U 4010-6-4
167	--	63		78	93	M8	9	14	16	70	81,5	15 ~ 22	--	TD_U 4010-6-5
187	--	63		78	93	M8	9	14	16	70	81,5	16 ~ 24	--	TD_U 4010-6-6
207	--	63		78	93	M8	9	14	16	70	81,5	18 ~ 27	--	TD_U 4010-6-7
227	--	63		78	93	M8	9	14	16	70	81,5	20 ~ 29	--	TD_U 4010-6-8

Key dimensions of the cylindrical nut: N, M, Y are obtained in the tables of page 38 of the catalogue.

SHUTON advises to use the dimensions of the tables, although it is possible to manufacture ball screw with other dimensions.

Smaller nut diameters than the first option of the table can reduce the rigidity of the assembly between 5 and 10%.

Please consult SHUTON.

COMPLEX, Double Nut (1start), Ultracompact Nut

Ball screw reference	Nominal diameter	Lead	Ball diameter	Root diameter	Circuits	Dynamic load capacity	Static load capacity	Rigidity of ball contact zone, with Fpr:10%Ca	Rigidity of nut, with Fpr:10%Ca
TDB Flanged double nut TDL Cylindrical double nut TDBC Centre flanged double nut TUCB Flanged Ultracompact nut TUCL Cylindrical Ultracompact nut	d_0	P_h	D_w	d_2	$i (I_e)$	$C_a(N)$	$C_{oa} (N)$	$R_{b/t,pr} (N/\mu m)$	$R_{nu} (N/\mu m)$
TD_-U 4012-6-2	40	12	6,35	34,5	2	33800	56400	1060	1010
TD_-U 4012-6-3	40	12	6,35	34,5	3	48000	91300	1620	1550
TD_-U 4012-6-4	40	12	6,35	34,5	4	61500	124500	2180	2070
TD_-U 4012-6-5	40	12	6,35	34,5	5	74800	157700	2690	2560
TD_-U 4012-6-6	40	12	6,35	34,5	6	88300	192600	3220	3070
TD_-U 4012-6-7	40	12	6,35	34,5	7	101000	225800	3700	3530
TD_-U 4012-6-8	40	12	6,35	34,5	8	114000	260600	4190	3990
TD_-U 4015-6-2	40	15	6,35	34,5	2	33700	56300	1050	1020
TD_-U 4015-6-3	40	15	6,35	34,5	3	47800	91100	1620	1560
TD_-U 4015-6-4	40	15	6,35	34,5	4	61300	124200	2170	2090
TD_-U 4015-6-5	40	15	6,35	34,5	5	75100	159000	2700	2600
TD_-U 4015-6-6	40	15	6,35	34,5	6	88000	192100	3200	3090
TD_-U 4015-6-7	40	15	6,35	34,5	7	100700	225200	3680	3550
TD_-U 4016-6-2	40	16	6,35	34,5	2	33600	56300	1050	1020
TD_-U 4016-6-3	40	16	6,35	34,5	3	47700	91000	1610	1560
TD_-U 4016-6-4	40	16	6,35	34,5	4	61200	124100	2160	2090
TD_-U 4016-6-5	40	16	6,35	34,5	5	75000	158800	2700	2600
TD_-U 4016-6-6	40	16	6,35	34,5	6	87900	191900	3200	3090
TD_/TUC_-U 4020-6-2	40	20	6,35	34,5	2	34100	57700	1070	1040
TD_/TUC_-U 4020-6-3	40	20	6,35	34,5	3	47500	90600	1600	1550
TD_/TUC_-U 4020-6-4	40	20	6,35	34,5	4	61400	125200	2170	2110
TD_/TUC_-U 4020-6-5	40	20	6,35	34,5	5	74600	158200	2670	2600
TD_/TUC_-U 4025-6-2	40	25	6,35	34,5	2	33800	57300	1060	1030
TD_/TUC_-U 4025-6-3	40	25	6,35	34,5	3	47700	91700	1600	1570
TD_/TUC_-U 4025-6-4	40	25	6,35	34,5	4	60900	124400	2140	2090
TD_/TUC_-U 4030-6-2	40	30	6,35	34,5	2	33500	56800	1040	1020
TD_/TUC_-U 4030-6-3	40	30	6,35	34,5	3	47200	90900	1580	1550
TD_/TUC_-U 4040-6-2	40	40	6,35	34,5	2	33200	57300	1020	1010
TD_/TUC_-U 4050-6-2	40	50	6,35	34,5	2	32800	57500	1000	990
TD_/TUC_-U 4060-6-2	40	60	6,35	34,5	2	32200	57400	960	960
TD_-U 4015-8-2	40	15	7,938	33,3	2	46100	73300	1160	1120
TD_-U 4015-8-3	40	15	7,938	33,3	3	64700	116700	1770	1720
TD_-U 4015-8-4	40	15	7,938	33,3	4	84300	162800	2420	2340
TD_-U 4015-8-5	40	15	7,938	33,3	5	102500	206300	3000	2910
TD_-U 4015-8-6	40	15	7,938	33,3	6	121200	252400	3580	3470
TD_-U 4016-8-2	40	16	7,938	33,3	2	46000	73200	1150	1120
TD_-U 4016-8-3	40	16	7,938	33,3	3	64700	116600	1770	1720
TD_-U 4016-8-4	40	16	7,938	33,3	4	84200	162700	2420	2350
TD_-U 4016-8-5	40	16	7,938	33,3	5	102400	206100	2990	2910
TD_-U 4016-8-6	40	16	7,938	33,3	6	121100	252200	3570	3470
TD_-U 4020-8-2	40	20	7,938	33,3	2	45800	72900	1140	1120

* C_a and C_{oa} : Modified static and dynamic load capacities, calculated according to DIN 69051/4 standard and ISO3408/5. See pages 39 and 43.

** $R_{b/t,pr}$: Rigidity of the balls contact zone for an external force 10% of C_a . See page 47. For a different preload force, multiply by $\sqrt[3]{F_{pr}/0,1 C_a}$

*** R_{nu} : Total rigidity of the complete nut. It must be multiplied by the factor f_{at} , which depends on the manufacturing tolerance. See page 48.

Nut length 1 start	Nut length 2 starts	Nut dimensions										Grease quantity TD 'steel ball'	Grease quantity TUC 'steel ball'	Ball screw reference	
		$D_{1, std}$	$D_{1, min}$	D_4	D_6	M	D_5	L_7	L_1	L_8	L_9				$Q_{gr, real, TD}$ (cm^3)
TDB	TUC														
106	--	63		78	93	M8	9	14	20	70	81,5	8,8 ~ 13	--	TD_U 4012-6-2	
130	--	63		78	93	M8	9	14	20	70	81,5	10 ~ 15	--	TD_U 4012-6-3	
154	--	63		78	93	M8	9	14	20	70	81,5	12 ~ 18	--	TD_U 4012-6-4	
178	--	63		78	93	M8	9	14	20	70	81,5	14 ~ 20	--	TD_U 4012-6-5	
202	--	63		78	93	M8	9	14	20	70	81,5	15 ~ 23	--	TD_U 4012-6-6	
226	--	63		78	93	M8	9	14	20	70	81,5	17 ~ 26	--	TD_U 4012-6-7	
250	--	63		78	93	M8	9	14	20	70	81,5	19 ~ 28	--	TD_U 4012-6-8	
118	--	65	(63)	78	93	M8	9	16	20	70	81,5	8,6 ~ 13	--	TD_U 4015-6-2	
148	--	65	(63)	78	93	M8	9	16	20	70	81,5	10 ~ 16	--	TD_U 4015-6-3	
178	--	65	(63)	78	93	M8	9	16	20	70	81,5	12 ~ 18	--	TD_U 4015-6-4	
208	--	65	(63)	78	93	M8	9	16	20	70	81,5	14 ~ 21	--	TD_U 4015-6-5	
238	--	65	(63)	78	93	M8	9	16	20	70	81,5	16 ~ 24	--	TD_U 4015-6-6	
268	--	65	(63)	78	93	M8	9	16	20	70	81,5	18 ~ 27	--	TD_U 4015-6-7	
131	--	65	(63)	78	93	M8	9	16	20	70	81,5	9,6 ~ 14	--	TD_U 4016-6-2	
163	--	65	(63)	78	93	M8	9	16	20	70	81,5	12 ~ 17	--	TD_U 4016-6-3	
195	--	65	(63)	78	93	M8	9	16	20	70	81,5	13 ~ 20	--	TD_U 4016-6-4	
227	--	65	(63)	78	93	M8	9	16	20	70	81,5	15 ~ 23	--	TD_U 4016-6-5	
259	--	65	(63)	78	93	M8	9	16	20	70	81,5	17 ~ 26	--	TD_U 4016-6-6	
134	75	65	(63)	78	93	M8	9	18	20	70	81,5	8,3 ~ 12	5,6 ~ 8,3	TD/TUC_U 4020-6-2	
174	95	65	(63)	78	93	M8	9	18	20	70	81,5	11 ~ 16	7 ~ 11	TD/TUC_U 4020-6-3	
214	115	65	(63)	78	93	M8	9	18	20	70	81,5	13 ~ 19	8,3 ~ 13	TD/TUC_U 4020-6-4	
254	135	65	(63)	78	93	M8	9	18	20	70	81,5	15 ~ 23	9,9 ~ 15	TD/TUC_U 4020-6-5	
158	82	65	(63)	78	93	M8	9	18	20	70	81,5	9,2 ~ 14	5,3 ~ 7,9	TD/TUC_U 4025-6-2	
208	107	65	(63)	78	93	M8	9	18	20	70	81,5	12 ~ 18	6,9 ~ 10	TD/TUC_U 4025-6-3	
258	132	65	(63)	78	93	M8	9	18	20	70	81,5	15 ~ 22	8,5 ~ 13	TD/TUC_U 4025-6-4	
168	87	65	(63)	78	93	M8	9	18	20	70	81,5	9 ~ 13	5 ~ 7,5	TD/TUC_U 4030-6-2	
228	117	65	(63)	78	93	M8	9	18	20	70	81,5	12 ~ 18	6,8 ~ 10	TD/TUC_U 4030-6-3	
208	107	65	(63)	78	93	M8	9	18	20	70	81,5	10 ~ 15	5,4 ~ 8,1	TD/TUC_U 4040-6-2	
240	124	65	(63)	78	93	M8	9	18	20	70	81,5	11 ~ 17	6 ~ 9	TD/TUC_U 4050-6-2	
276	142	65	(63)	78	93	M8	9	18	20	70	81,5	12 ~ 19	6,6 ~ 10	TD/TUC_U 4060-6-2	
131	--	70		85	100	M8	9	18	25	75	87,5	14 ~ 22	--	TD_U 4015-8-2	
161	--	70		85	100	M8	9	18	25	75	87,5	17 ~ 26	--	TD_U 4015-8-3	
191	--	70		85	100	M8	9	18	25	75	87,5	20 ~ 29	--	TD_U 4015-8-4	
221	--	70		85	100	M8	9	18	25	75	87,5	22 ~ 34	--	TD_U 4015-8-5	
251	--	70		85	100	M8	9	18	25	75	87,5	25 ~ 38	--	TD_U 4015-8-6	
128	--	70		85	100	M8	9	18	25	75	87,5	13 ~ 20	--	TD_U 4016-8-2	
160	--	70		85	100	M8	9	18	25	75	87,5	16 ~ 24	--	TD_U 4016-8-3	
192	--	70		85	100	M8	9	18	25	75	87,5	19 ~ 28	--	TD_U 4016-8-4	
224	--	70		85	100	M8	9	18	25	75	87,5	22 ~ 32	--	TD_U 4016-8-5	
256	--	70		85	100	M8	9	18	25	75	87,5	24 ~ 37	--	TD_U 4016-8-6	
140	--	70		85	100	M8	9	18	25	75	87,5	13 ~ 19	--	TD_U 4020-8-2	

Key dimensions of the cylindrical nut: N, M, Y are obtained in the tables of page 38 of the catalogue.

SHUTON advises to use the dimensions of the tables, although it is possible to manufacture ball screw with other dimensions.

Smaller nut diameters than the first option of the table can reduce the rigidity of the assembly between 5 and 10%.

Please consult SHUTON.

COMPLEX, Double Nut (1start), Ultracompact Nut

Ball screw reference	Nominal diameter	Lead	Ball diameter	Root diameter	Circuits	Dynamic load capacity	Static load capacity	Rigidity of ball contact zone, with Fpr:10%Ca	Rigidity of nut, with Fpr:10%Ca
TDB Flanged double nut TDL Cylindrical double nut TDBC Centre flanged double nut TUCB Flanged Ultracompact nut TUCL Cylindrical Ultracompact nut	d_0	P_h	D_w	d_2	$i (I_e)$	$C_a(N)$	$C_{oa} (N)$	$R_{b/t,pr} (N/\mu m)$	$R_{nu} (N/\mu m)$
TD_-U 4020-8-3	40	20	7,938	33,3	3	64300	116100	1750	1710
TD_-U 4020-8-4	40	20	7,938	33,3	4	83800	162000	2400	2340
TD_-U 4020-8-5	40	20	7,938	33,3	5	102700	207900	3000	2930
TD_/TUC_-U 4025-8-2	40	25	7,938	33,3	2	45400	72400	1130	1110
TD_/TUC_-U 4025-8-3	40	25	7,938	33,3	3	64800	118100	1770	1730
TD_/TUC_-U 4025-8-4	40	25	7,938	33,3	4	83100	161000	2360	2320
TD_/TUC_-U 4030-8-2	40	30	7,938	33,3	2	44900	71900	1110	1090
TD_/TUC_-U 4030-8-3	40	30	7,938	33,3	3	64100	117100	1740	1710
TD_/TUC_-U 4040-8-2	40	40	7,938	33,3	2	44900	73100	1100	1090
TD_/TUC_-U 4050-8-2	40	50	7,938	33,3	2	44600	74000	1090	1080
TD_/TUC_-U 4060-8-2	40	60	7,938	33,3	2	44000	74500	1060	1050
TD_-U 5010-6-2	50	10	6,35	44,5	2	38900	74100	1310	1220
TD_-U 5010-6-3	50	10	6,35	44,5	3	54100	116200	2000	1850
TD_-U 5010-6-4	50	10	6,35	44,5	4	69900	159900	2660	2470
TD_-U 5010-6-5	50	10	6,35	44,5	5	84800	202000	3290	3050
TD_-U 5010-6-6	50	10	6,35	44,5	6	99400	244100	3900	3620
TD_-U 5010-6-7	50	10	6,35	44,5	7	114200	287900	4510	4190
TD_-U 5012-6-2	50	12	6,35	44,5	2	38900	74000	1310	1230
TD_-U 5012-6-3	50	12	6,35	44,5	3	54100	116100	1990	1870
TD_-U 5012-6-4	50	12	6,35	44,5	4	69800	159800	2660	2490
TD_-U 5012-6-5	50	12	6,35	44,5	5	84700	201900	3290	3090
TD_-U 5012-6-6	50	12	6,35	44,5	6	99300	243900	3890	3660
TD_-U 5012-6-7	50	12	6,35	44,5	7	114100	287600	4500	4230
TD_-U 5015-6-2	50	15	6,35	44,5	2	38800	73900	1310	1240
TD_-U 5015-6-3	50	15	6,35	44,5	3	54500	117600	2010	1910
TD_-U 5015-6-4	50	15	6,35	44,5	4	69700	159600	2650	2520
TD_-U 5015-6-5	50	15	6,35	44,5	5	84600	201500	3280	3110
TD_-U 5015-6-6	50	15	6,35	44,5	6	99600	245200	3910	3720
TD_-U 5015-6-7	50	15	6,35	44,5	7	113800	287200	4490	4270
TD_-U 5016-6-2	50	16	6,35	44,5	2	38800	73900	1310	1250
TD_-U 5016-6-3	50	16	6,35	44,5	3	54400	117500	2010	1910
TD_-U 5016-6-4	50	16	6,35	44,5	4	69600	159500	2640	2520
TD_-U 5016-6-5	50	16	6,35	44,5	5	84500	201400	3270	3120
TD_-U 5016-6-6	50	16	6,35	44,5	6	99500	245100	3900	3720
TD_-U 5016-6-7	50	16	6,35	44,5	7	113700	287000	4480	4280
TD_/TUC_-U 5020-6-2	50	20	6,35	44,5	2	38600	73600	1300	1250
TD_/TUC_-U 5020-6-3	50	20	6,35	44,5	3	54200	117200	2000	1920
TD_/TUC_-U 5020-6-4	50	20	6,35	44,5	4	69400	159000	2630	2530
TD_/TUC_-U 5020-6-5	50	20	6,35	44,5	5	84600	202500	3280	3150
TD_/TUC_-U 5020-6-6	50	20	6,35	44,5	6	99100	244400	3880	3730
TD_/TUC_-U 5020-6-7	50	20	6,35	44,5	7	113800	287900	4480	4320

* C_a and C_{oa} : Modified static and dynamic load capacities, calculated according to DIN 69051/4 standard and ISO3408/5. See pages 39 and 43.

** $R_{b/t,pr}$: Rigidity of the balls contact zone for an external force 10% of C_a . See page 47. For a different preload force, multiply by $\sqrt[3]{F_{pr}/0,1 C_a}$

*** R_{nu} : Total rigidity of the complete nut. It must be multiplied by the factor $f_{a'}$, which depends on the manufacturing tolerance. See page 48.

Nut length 1 start	Nut length 2 starts	Nut dimensions										Grease quantity TD 'steel ball'	Grease quantity TUC 'steel ball'	Ball screw reference
		$D_{1, std}$	$D_{1, min}$	D_4	D_6	M	D_5	L_7	L_1	L_8	L_9			
<i>TDB</i>	<i>TUC</i>											$Q_{gr, real, TD}$ (cm^3)	$Q_{gr, real, TUC}$ (cm^3)	
180	--	70		85	100	M8	9	18	25	75	87,5	16 ~ 24	--	TD_U 4020-8-3
220	--	70		85	100	M8	9	18	25	75	87,5	19 ~ 29	--	TD_U 4020-8-4
260	--	70		85	100	M8	9	18	25	75	87,5	23 ~ 34	--	TD_U 4020-8-5
163	92	70		85	100	M8	9	18	25	75	87,5	14 ~ 21	9,2 ~ 14	TD_/TUC_U 4025-8-2
213	117	70		85	100	M8	9	18	25	75	87,5	18 ~ 27	11 ~ 17	TD_/TUC_U 4025-8-3
263	142	70		85	100	M8	9	18	25	75	87,5	22 ~ 33	14 ~ 21	TD_/TUC_U 4025-8-4
176	98	70		85	100	M8	9	18	25	75	87,5	14 ~ 21	8,8 ~ 13	TD_/TUC_U 4030-8-2
234	128	70		85	100	M8	9	18	25	75	87,5	18 ~ 28	11 ~ 17	TD_/TUC_U 4030-8-3
210	112	70		85	100	M8	9	18	25	75	87,5	15 ~ 23	8,6 ~ 13	TD_/TUC_U 4040-8-2
238	123	70		85	100	M8	9	18	25	75	87,5	16 ~ 25	8,4 ~ 13	TD_/TUC_U 4050-8-2
272	140	70		85	100	M8	9	18	25	75	87,5	18 ~ 27	9,3 ~ 14	TD_/TUC_U 4060-8-2
108	--	75		93	110	M10	11	16	16	85	97,5	13 ~ 20	--	TD_U 5010-6-2
128	--	75		93	110	M10	11	16	16	85	97,5	15 ~ 22	--	TD_U 5010-6-3
148	--	75		93	110	M10	11	16	16	85	97,5	17 ~ 25	--	TD_U 5010-6-4
168	--	75		93	110	M10	11	16	16	85	97,5	18 ~ 28	--	TD_U 5010-6-5
188	--	75		93	110	M10	11	16	16	85	97,5	20 ~ 31	--	TD_U 5010-6-6
208	--	75		93	110	M10	11	16	16	85	97,5	22 ~ 33	--	TD_U 5010-6-7
108	--	75		93	110	M10	11	16	20	85	97,5	11 ~ 17	--	TD_U 5012-6-2
132	--	75		93	110	M10	11	16	20	85	97,5	13 ~ 20	--	TD_U 5012-6-3
156	--	75		93	110	M10	11	16	20	85	97,5	15 ~ 22	--	TD_U 5012-6-4
180	--	75		93	110	M10	11	16	20	85	97,5	17 ~ 26	--	TD_U 5012-6-5
204	--	75		93	110	M10	11	16	20	85	97,5	19 ~ 29	--	TD_U 5012-6-6
228	--	75		93	110	M10	11	16	20	85	97,5	21 ~ 32	--	TD_U 5012-6-7
118	--	75		93	110	M10	11	16	20	85	97,5	11 ~ 16	--	TD_U 5015-6-2
148	--	75		93	110	M10	11	16	20	85	97,5	13 ~ 19	--	TD_U 5015-6-3
178	--	75		93	110	M10	11	16	20	85	97,5	15 ~ 23	--	TD_U 5015-6-4
208	--	75		93	110	M10	11	16	20	85	97,5	17 ~ 26	--	TD_U 5015-6-5
238	--	75		93	110	M10	11	16	20	85	97,5	20 ~ 30	--	TD_U 5015-6-6
268	--	75		93	110	M10	11	16	20	85	97,5	22 ~ 34	--	TD_U 5015-6-7
132	--	75		93	110	M10	11	16	20	85	97,5	12 ~ 18	--	TD_U 5016-6-2
164	--	75		93	110	M10	11	16	20	85	97,5	14 ~ 21	--	TD_U 5016-6-3
196	--	75		93	110	M10	11	16	20	85	97,5	17 ~ 25	--	TD_U 5016-6-4
228	--	75		93	110	M10	11	16	20	85	97,5	19 ~ 29	--	TD_U 5016-6-5
260	--	75		93	110	M10	11	16	20	85	97,5	22 ~ 33	--	TD_U 5016-6-6
292	--	75		93	110	M10	11	16	20	85	97,5	24 ~ 37	--	TD_U 5016-6-7
136	75	75		93	110	M10	11	18	25	85	97,5	11 ~ 16	6,9 ~ 10	TD_/TUC_U 5020-6-2
176	95	75		93	110	M10	11	18	25	85	97,5	13 ~ 20	8,5 ~ 13	TD_/TUC_U 5020-6-3
216	115	75		93	110	M10	11	18	25	85	97,5	16 ~ 24	10 ~ 16	TD_/TUC_U 5020-6-4
256	135	75		93	110	M10	11	18	25	85	97,5	19 ~ 28	12 ~ 18	TD_/TUC_U 5020-6-5
296	155	75		93	110	M10	11	18	25	85	97,5	22 ~ 33	14 ~ 21	TD_/TUC_U 5020-6-6
336	175	75		93	110	M10	11	18	25	85	97,5	25 ~ 38	16 ~ 24	TD_/TUC_U 5020-6-7

Key dimensions of the cylindrical nut: N, M, Y are obtained in the tables of page 38 of the catalogue.

SHUTON advises to use the dimensions of the tables, although it is possible to manufacture ball screw with other dimensions.

Smaller nut diameters than the first option of the table can reduce the rigidity of the assembly between 5 and 10%.

Please consult SHUTON.

COMPLEX, Double Nut (1start), Ultracompact Nut

Ball screw reference	Nominal diameter	Lead	Ball diameter	Root diameter	Circuits	Dynamic load capacity	Static load capacity	Rigidity of ball contact zone, with Fpr:10%Ca	Rigidity of nut, with Fpr:10%Ca
TDB Flanged double nut TDL Cylindrical double nut TDBC Centre flanged double nut TUCB Flanged Ultracompact nut TUCL Cylindrical Ultracompact nut	d_0	P_h	D_w	d_2	$i (I_e)$	$C_a(N)$	$C_{oa} (N)$	$R_{b/t,pr} (N/\mu m)$	$R_{nu} (N/\mu m)$
TD_/TUC_-U 5025-6-2	50	25	6,35	44,5	2	39000	75000	1320	1280
TD_/TUC_-U 5025-6-3	50	25	6,35	44,5	3	53900	116700	1980	1920
TD_/TUC_-U 5025-6-4	50	25	6,35	44,5	4	69500	160000	2630	2550
TD_/TUC_-U 5025-6-5	50	25	6,35	44,5	5	84200	201700	3250	3150
TD_/TUC_-U 5025-6-6	50	25	6,35	44,5	6	99000	245000	3870	3750
TD_/TUC_-U 5030-6-2	50	30	6,35	44,5	2	38700	74600	1300	1270
TD_/TUC_-U 5030-6-3	50	30	6,35	44,5	3	54100	117700	1990	1930
TD_/TUC_-U 5030-6-4	50	30	6,35	44,5	4	69000	159200	2600	2540
TD_/TUC_-U 5030-6-5	50	30	6,35	44,5	5	84100	202300	3240	3160
TD_/TUC_-U 5040-6-2	50	40	6,35	44,5	2	38600	75300	1290	1270
TD_/TUC_-U 5040-6-3	50	40	6,35	44,5	3	53700	117800	1960	1920
TD_/TUC_-U 5040-6-4	50	40	6,35	44,5	4	68800	160400	2580	2530
TD_/TUC_-U 5050-6-2	50	50	6,35	44,5	2	37800	74100	1250	1230
TD_/TUC_-U 5050-6-3	50	50	6,35	44,5	3	53000	117600	1920	1890
TD_/TUC_-U 5060-6-2	50	60	6,35	44,5	2	37400	74200	1220	1210
TD_/TUC_-U 5080-6-2	50	80	6,35	44,5	2	36800	75500	1180	1170
TD_-U 5012-8-2	50	12	7,938	43,3	2	52600	93900	1430	1360
TD_-U 5012-8-3	50	12	7,938	43,3	3	74700	151900	2200	2090
TD_-U 5012-8-4	50	12	7,938	43,3	4	95800	207200	2920	2780
TD_-U 5012-8-5	50	12	7,938	43,3	5	117400	265200	3680	3500
TD_-U 5012-8-6	50	12	7,938	43,3	6	137600	320500	4360	4150
TD_-U 5012-8-7	50	12	7,938	43,3	7	158200	378500	5050	4800
TD_-U 5012-8-8	50	12	7,938	43,3	8	177600	433700	5670	5400
TD_-U 5015-8-2	50	15	7,938	43,3	2	52500	93800	1430	1370
TD_-U 5015-8-3	50	15	7,938	43,3	3	74600	151700	2190	2100
TD_-U 5015-8-4	50	15	7,938	43,3	4	95700	206900	2920	2800
TD_-U 5015-8-5	50	15	7,938	43,3	5	117100	264800	3670	3520
TD_-U 5015-8-6	50	15	7,938	43,3	6	137300	320000	4350	4180
TD_-U 5015-8-7	50	15	7,938	43,3	7	157900	377900	5040	4840
TD_-U 5015-8-8	50	15	7,938	43,3	8	177200	433100	5650	5430
TD_-U 5016-8-2	50	16	7,938	43,3	2	52500	93700	1430	1380
TD_-U 5016-8-3	50	16	7,938	43,3	3	74500	151600	2190	2110
TD_-U 5016-8-4	50	16	7,938	43,3	4	95600	206800	2910	2800
TD_-U 5016-8-5	50	16	7,938	43,3	5	117000	264700	3660	3520
TD_-U 5016-8-6	50	16	7,938	43,3	6	137200	319800	4340	4180
TD_-U 5016-8-7	50	16	7,938	43,3	7	157700	377700	5030	4840
TD_-U 5016-8-8	50	16	7,938	43,3	8	177100	432800	5650	5440
TD_-U 5020-8-2	50	20	7,938	43,3	2	53300	96200	1460	1410
TD_-U 5020-8-3	50	20	7,938	43,3	3	74300	151200	2180	2110
TD_-U 5020-8-4	50	20	7,938	43,3	4	96100	209000	2930	2840
TD_-U 5020-8-5	50	20	7,938	43,3	5	116600	263900	3640	3530

* Ca and Coa: Modified static and dynamic load capacities, calculated according to DIN 69051/4 standard and ISO3408/5. See pages 39 and 43.

** Rb/t,pr: Rigidity of the balls contact zone for an external force 10% of Ca. See page 47. For a different preload force, multiply by $\sqrt[3]{F_{pr}/0,1 C_a}$

*** Rnu: Total rigidity of the complete nut. It must be multiplied by the factor f_{ar} , which depends on the manufacturing tolerance. See page 48.

Nut length 1 start	Nut length 2 starts	Nut dimensions										Grease quantity TD 'steel ball'	Grease quantity TUC 'steel ball'	Ball screw reference
		$D_{1, std}$	$D_{1, min}$	D_4	D_6	M	D_5	L_7	L_1	L_8	L_9			
TDB	TUC											$Q_{gr, real, TD}$ (cm^3)	$Q_{gr, real, TUC}$ (cm^3)	
159	80	75		93	110	M10	11	18	25	85	97,5	11 ~ 17	6,1 ~ 9,2	TD_/TUC_-U 5025-6-2
210	105	75		93	110	M10	11	18	25	85	97,5	15 ~ 22	8,1 ~ 12	TD_/TUC_-U 5025-6-3
259	130	75		93	110	M10	11	18	25	85	97,5	18 ~ 27	10 ~ 15	TD_/TUC_-U 5025-6-4
309	155	75		93	110	M10	11	18	25	85	97,5	22 ~ 32	12 ~ 18	TD_/TUC_-U 5025-6-5
359	180	75		93	110	M10	11	18	25	85	97,5	25 ~ 38	14 ~ 22	TD_/TUC_-U 5025-6-6
183	89	75		93	110	M10	11	18	25	85	97,5	13 ~ 19	6,4 ~ 9,5	TD_/TUC_-U 5030-6-2
243	119	75		93	110	M10	11	18	25	85	97,5	16 ~ 24	8,5 ~ 13	TD_/TUC_-U 5030-6-3
303	149	75		93	110	M10	11	18	25	85	97,5	20 ~ 30	11 ~ 16	TD_/TUC_-U 5030-6-4
363	179	75		93	110	M10	11	18	25	85	97,5	24 ~ 36	13 ~ 20	TD_/TUC_-U 5030-6-5
208	107	75		93	110	M10	11	18	25	85	97,5	13 ~ 19	7 ~ 10	TD_/TUC_-U 5040-6-2
288	147	75		93	110	M10	11	18	25	85	97,5	18 ~ 27	9,7 ~ 15	TD_/TUC_-U 5040-6-3
368	187	75		93	110	M10	11	18	25	85	97,5	23 ~ 34	13 ~ 19	TD_/TUC_-U 5040-6-4
248	128	75		93	110	M10	11	18	25	85	97,5	14 ~ 21	8,1 ~ 12	TD_/TUC_-U 5050-6-2
347	177	75		93	110	M10	11	18	25	85	97,5	20 ~ 30	11 ~ 17	TD_/TUC_-U 5050-6-3
282	145	75		93	110	M10	11	18	25	85	97,5	16 ~ 24	8,5 ~ 13	TD_/TUC_-U 5060-6-2
354	181	75		93	110	M10	11	18	25	85	97,5	19 ~ 29	10 ~ 15	TD_/TUC_-U 5080-6-2
116	--	82		100	118	M10	11	16	25	92	105	18 ~ 26	--	TD_-U 5012-8-2
140	--	82		100	118	M10	11	16	25	92	105	20 ~ 30	--	TD_-U 5012-8-3
164	--	82		100	118	M10	11	16	25	92	105	23 ~ 35	--	TD_-U 5012-8-4
188	--	82		100	118	M10	11	16	25	92	105	26 ~ 39	--	TD_-U 5012-8-5
212	--	82		100	118	M10	11	16	25	92	105	29 ~ 43	--	TD_-U 5012-8-6
236	--	82		100	118	M10	11	16	25	92	105	32 ~ 48	--	TD_-U 5012-8-7
260	--	82		100	118	M10	11	16	25	92	105	35 ~ 53	--	TD_-U 5012-8-8
132	--	82		100	118	M10	11	16	25	92	105	18 ~ 27	--	TD_-U 5015-8-2
164	--	82		100	118	M10	11	16	25	92	105	21 ~ 32	--	TD_-U 5015-8-3
192	--	82		100	118	M10	11	16	25	92	105	24 ~ 37	--	TD_-U 5015-8-4
222	--	82		100	118	M10	11	16	25	92	105	28 ~ 42	--	TD_-U 5015-8-5
252	--	82		100	118	M10	11	16	25	92	105	31 ~ 47	--	TD_-U 5015-8-6
282	--	82		100	118	M10	11	16	25	92	105	35 ~ 52	--	TD_-U 5015-8-7
312	--	82		100	118	M10	11	16	25	92	105	39 ~ 58	--	TD_-U 5015-8-8
130	--	82		100	118	M10	11	16	25	92	105	17 ~ 25	--	TD_-U 5016-8-2
162	--	82		100	118	M10	11	16	25	92	105	20 ~ 30	--	TD_-U 5016-8-3
194	--	82		100	118	M10	11	16	25	92	105	23 ~ 35	--	TD_-U 5016-8-4
226	--	82		100	118	M10	11	16	25	92	105	27 ~ 40	--	TD_-U 5016-8-5
258	--	82		100	118	M10	11	16	25	92	105	31 ~ 46	--	TD_-U 5016-8-6
290	--	82		100	118	M10	11	16	25	92	105	34 ~ 51	--	TD_-U 5016-8-7
322	--	82		100	118	M10	11	16	25	92	105	38 ~ 58	--	TD_-U 5016-8-8
144	--	82		100	118	M10	11	18	25	92	105	16 ~ 24	--	TD_-U 5020-8-2
184	--	82		100	118	M10	11	18	25	92	105	20 ~ 31	--	TD_-U 5020-8-3
224	--	82		100	118	M10	11	18	25	92	105	25 ~ 37	--	TD_-U 5020-8-4
264	--	82		100	118	M10	11	18	25	92	105	29 ~ 43	--	TD_-U 5020-8-5

Key dimensions of the cylindrical nut: N, M, Y are obtained in the tables of page 38 of the catalogue.

SHUTON advises to use the dimensions of the tables, although it is possible to manufacture ball screw with other dimensions.

Smaller nut diameters than the first option of the table can reduce the rigidity of the assembly between 5 and 10%.

Please consult SHUTON.

COMPLEX, Double Nut (1start), Ultracompact Nut

Ball screw reference	Nominal diameter	Lead	Ball diameter	Root diameter	Circuits	Dynamic load capacity	Static load capacity	Rigidity of ball contact zone, with Fpr:10%Ca	Rigidity of nut, with Fpr:10%Ca
TDB Flanged double nut TDL Cylindrical double nut TDBC Centre flanged double nut TUCB Flanged Ultracompact nut TUCL Cylindrical Ultracompact nut	d_0	P_h	D_w	d_2	$i (I_e)$	$C_a(N)$	$C_{oa} (N)$	$R_{b/t,pr} (N/\mu m)$	$R_{nu} (N/\mu m)$
TD_-U 5020-8-6	50	20	7,938	43,3	6	137500	321700	4360	4220
TD_-U 5020-8-7	50	20	7,938	43,3	7	157200	376700	5000	4850
TD_/TUC_-U 5025-8-2	50	25	7,938	43,3	2	53000	95800	1450	1410
TD_/TUC_-U 5025-8-3	50	25	7,938	43,3	3	73900	150600	2160	2110
TD_/TUC_-U 5025-8-4	50	25	7,938	43,3	4	95600	208100	2910	2830
TD_/TUC_-U 5025-8-5	50	25	7,938	43,3	5	116800	265600	3650	3560
TD_/TUC_-U 5025-8-6	50	25	7,938	43,3	6	136800	320300	4320	4210
TD_/TUC_-U 5030-8-2	50	30	7,938	43,3	2	52700	95300	1430	1400
TD_/TUC_-U 5030-8-3	50	30	7,938	43,3	3	74200	152500	2170	2130
TD_/TUC_-U 5030-8-4	50	30	7,938	43,3	4	94900	207000	2870	2820
TD_/TUC_-U 5030-8-5	50	30	7,938	43,3	5	116000	264200	3610	3530
TD_/TUC_-U 5040-8-2	50	40	7,938	43,3	2	52800	96800	1430	1410
TD_/TUC_-U 5040-8-3	50	40	7,938	43,3	3	73900	153300	2150	2120
TD_/TUC_-U 5040-8-4	50	40	7,938	43,3	4	95000	209800	2870	2820
TD_/TUC_-U 5050-8-2	50	50	7,938	43,3	2	51700	95300	1380	1370
TD_/TUC_-U 5050-8-3	50	50	7,938	43,3	3	73200	153500	2110	2090
TD_/TUC_-U 5060-8-2	50	60	7,938	43,3	2	51400	96100	1360	1350
TD_/TUC_-U 5080-8-2	50	80	7,938	43,3	2	50200	96900	1300	1290
TD_-B 5012,7-9-2	50	12,7	9,525	42,2	2	66200	111500	1430	1370
TD_-B 5012,7-9-3	50	12,7	9,525	42,2	3	93600	179200	2210	2110
TD_-B 5012,7-9-4	50	12,7	9,525	42,2	4	120800	246900	2960	2820
TD_-B 5012,7-9-5	50	12,7	9,525	42,2	5	148800	318500	3740	3560
TD_-B 5012,7-9-6	50	12,7	9,525	42,2	6	174800	386200	4470	4250
TD_-B 5012,7-9-7	50	12,7	9,525	42,2	7	200300	453900	5120	4880
TD_-B 5012,7-9-8	50	12,7	9,525	42,2	8	217200	493700	5710	5440
TD_-B 5012,7-9-9	50	12,7	9,525	42,2	9	243100	565400	6470	6170
TD_-B 5012,7-9-10	50	12,7	9,525	42,2	10	268600	637100	7220	6890
TD_-B 5012,7-9-11	50	12,7	9,525	42,2	11	291500	700800	7890	7530
TD_-U 5016-9-2	50	16	9,525	42,2	2	66000	111300	1430	1380
TD_-U 5016-9-3	50	16	9,525	42,2	3	93400	178900	2210	2130
TD_-U 5016-9-4	50	16	9,525	42,2	4	120600	246400	2950	2840
TD_-U 5016-9-5	50	16	9,525	42,2	5	148400	318000	3720	3590
TD_-U 5016-9-6	50	16	9,525	42,2	6	174400	385500	4450	4290
TD_-U 5016-9-7	50	16	9,525	42,2	7	199800	453100	5100	4930
TD_-U 5016-9-8	50	16	9,525	42,2	8	224800	520700	5750	5560
TD_-U 5020-9-2	50	20	9,525	42,2	2	65800	111000	1420	1380
TD_-U 5020-9-3	50	20	9,525	42,2	3	93000	178400	2190	2130
TD_-U 5020-9-4	50	20	9,525	42,2	4	121400	249700	2970	2890
TD_-U 5020-9-5	50	20	9,525	42,2	5	147900	317100	3700	3600
TD_-U 5020-9-6	50	20	9,525	42,2	6	173800	384500	4420	4300
TD_-U 5020-9-7	50	20	9,525	42,2	7	199100	451900	5070	4940

* C_a and C_{oa} : Modified static and dynamic load capacities, calculated according to DIN 69051/4 standard and ISO3408/5. See pages 39 and 43.

** $R_{b/t,pr}$: Rigidity of the balls contact zone for an external force 10% of C_a . See page 47. For a different preload force, multiply by $\sqrt[3]{F_{pr}/0,1 C_a}$

*** R_{nu} : Total rigidity of the complete nut. It must be multiplied by the factor f_{at} , which depends on the manufacturing tolerance. See page 48.

Nut length 1 start	Nut length 2 starts	Nut dimensions										Grease quantity TD 'steel ball'	Grease quantity TUC 'steel ball'	Ball screw reference
		$D_{1, std}$	$D_{1, min}$	D_4	D_6	M	D_5	L_7	L_1	L_8	L_9			
TDB	TUC											$Q_{gr, real, TD}$ (cm^3)	$Q_{gr, real, TUC}$ (cm^3)	
304	--	82		100	118	M10	11	18	25	92	105	33 ~ 49	--	TD_U 5020-8-6
344	--	82		100	118	M10	11	18	25	92	105	37 ~ 56	--	TD_U 5020-8-7
164	89	82		100	118	M10	11	18	25	92	105	17 ~ 26	10 ~ 15	TD/TUC_U 5025-8-2
214	114	82		100	118	M10	11	18	25	92	105	22 ~ 33	13 ~ 20	TD/TUC_U 5025-8-3
264	139	82		100	118	M10	11	18	25	92	105	27 ~ 41	16 ~ 24	TD/TUC_U 5025-8-4
314	164	82		100	118	M10	11	18	25	92	105	32 ~ 48	19 ~ 28	TD/TUC_U 5025-8-5
364	189	82		100	118	M10	11	18	25	92	105	37 ~ 56	22 ~ 33	TD/TUC_U 5025-8-6
188	95	82		100	118	M10	11	18	25	92	105	19 ~ 28	9,8 ~ 15	TD/TUC_U 5030-8-2
248	125	82		100	118	M10	11	18	25	92	105	25 ~ 37	13 ~ 20	TD/TUC_U 5030-8-3
308	155	82		100	118	M10	11	18	25	92	105	30 ~ 46	17 ~ 25	TD/TUC_U 5030-8-4
368	185	82		100	118	M10	11	18	25	92	105	36 ~ 54	20 ~ 30	TD/TUC_U 5030-8-5
218	109	82		100	118	M10	11	18	25	92	105	19 ~ 28	9,3 ~ 14	TD/TUC_U 5040-8-2
298	150	82		100	118	M10	11	18	25	92	105	26 ~ 39	14 ~ 21	TD/TUC_U 5040-8-3
376	189	82		100	118	M10	11	18	25	92	105	34 ~ 50	18 ~ 26	TD/TUC_U 5040-8-4
252	127	82		100	118	M10	11	18	25	92	105	21 ~ 32	11 ~ 16	TD/TUC_U 5050-8-2
352	177	82		100	118	M10	11	18	25	92	105	30 ~ 45	15 ~ 23	TD/TUC_U 5050-8-3
282	145	82		100	118	M10	11	18	25	92	105	23 ~ 34	12 ~ 18	TD/TUC_U 5060-8-2
352	180	82		100	118	M10	11	18	25	92	105	28 ~ 42	14 ~ 21	TD/TUC_U 5080-8-2
127	--	85		105	125	M12	13,5	35	25	95	110	29 ~ 44	--	TD_B 5012,7-9-2
153	--	85		105	125	M12	13,5	35	25	95	110	33 ~ 50	--	TD_B 5012,7-9-3
178	--	85		105	125	M12	13,5	35	25	95	110	37 ~ 56	--	TD_B 5012,7-9-4
204	--	85		105	125	M12	13,5	35	25	95	110	41 ~ 61	--	TD_B 5012,7-9-5
229	--	85		105	125	M12	13,5	35	25	95	110	45 ~ 67	--	TD_B 5012,7-9-6
254	--	85		105	125	M12	13,5	35	25	95	110	49 ~ 74	--	TD_B 5012,7-9-7
292	--	85		105	125	M12	13,5	35	25	95	110	58 ~ 87	--	TD_B 5012,7-9-8
318	--	85		105	125	M12	13,5	35	25	95	110	62 ~ 93	--	TD_B 5012,7-9-9
343	--	85		105	125	M12	13,5	35	25	95	110	65 ~ 98	--	TD_B 5012,7-9-10
358	--	85		105	125	M12	13,5	35	25	95	110	66 ~ 99	--	TD_B 5012,7-9-11
153	--	90	(85)	108 (103)	125 (120)	M10	11	20	25	95 (90)	110 (105)	28 ~ 42	--	TD_U 5016-9-2
185	--	90	(85)	108 (103)	125 (120)	M10	11	20	25	95 (90)	110 (105)	33 ~ 49	--	TD_U 5016-9-3
217	--	90	(85)	108 (103)	125 (120)	M10	11	20	25	95 (90)	110 (105)	37 ~ 56	--	TD_U 5016-9-4
249	--	90	(85)	108 (103)	125 (120)	M10	11	20	25	95 (90)	110 (105)	42 ~ 63	--	TD_U 5016-9-5
281	--	90	(85)	108 (103)	125 (120)	M10	11	20	25	95 (90)	110 (105)	46 ~ 70	--	TD_U 5016-9-6
313	--	90	(85)	108 (103)	125 (120)	M10	11	20	25	95 (90)	110 (105)	52 ~ 78	--	TD_U 5016-9-7
345	--	90	(85)	108 (103)	125 (120)	M10	11	20	25	95 (90)	110 (105)	57 ~ 86	--	TD_U 5016-9-8
167	--	90	(85)	108 (103)	125 (120)	M10	11	20	25	95 (90)	110 (105)	27 ~ 41	--	TD_U 5020-9-2
207	--	90	(85)	108 (103)	125 (120)	M10	11	20	25	95 (90)	110 (105)	33 ~ 49	--	TD_U 5020-9-3
247	--	90	(85)	108 (103)	125 (120)	M10	11	20	25	95 (90)	110 (105)	38 ~ 57	--	TD_U 5020-9-4
287	--	90	(85)	108 (103)	125 (120)	M10	11	20	25	95 (90)	110 (105)	44 ~ 65	--	TD_U 5020-9-5
327	--	90	(85)	108 (103)	125 (120)	M10	11	20	25	95 (90)	110 (105)	49 ~ 74	--	TD_U 5020-9-6
367	--	90	(85)	108 (103)	125 (120)	M10	11	20	25	95 (90)	110 (105)	55 ~ 83	--	TD_U 5020-9-7

Key dimensions of the cylindrical nut: N, M, Y are obtained in the tables of page 38 of the catalogue.

SHUTON advises to use the dimensions of the tables, although it is possible to manufacture ball screw with other dimensions.

Smaller nut diameters than the first option of the table can reduce the rigidity of the assembly between 5 and 10%.

Please consult SHUTON.

COMPLEX, Double Nut (1start), Ultracompact Nut

Ball screw reference	Nominal diameter	Lead	Ball diameter	Root diameter	Circuits	Dynamic load capacity	Static load capacity	Rigidity of ball contact zone, with Fpr:10%Ca	Rigidity of nut, with Fpr:10%Ca
TDB Flanged double nut TDL Cylindrical double nut TDBC Centre flanged double nut TUCB Flanged Ultracompact nut TUCL Cylindrical Ultracompact nut	d_0	P_h	D_w	d_2	$i (I_e)$	$C_a(N)$	$C_{oa} (N)$	$R_{b/t,pr} (N/\mu m)$	$R_{nu} (N/\mu m)$
TD_-U 5025-9-2	50	25	9,525	42,2	2	65400	110500	1410	1380
TD_-U 5025-9-3	50	25	9,525	42,2	3	93900	181600	2220	2170
TD_-U 5025-9-4	50	25	9,525	42,2	4	120800	248700	2950	2880
TD_-U 5025-9-5	50	25	9,525	42,2	5	147100	315800	3670	3590
TD_-U 5025-9-6	50	25	9,525	42,2	6	174000	386900	4430	4330
TD_-U 5030-9-2	50	30	9,525	42,2	2	65000	110000	1390	1370
TD_-U 5030-9-3	50	30	9,525	42,2	3	93300	180700	2200	2160
TD_-U 5030-9-4	50	30	9,525	42,2	4	120000	247500	2920	2860
TD_-U 5030-9-5	50	30	9,525	42,2	5	147400	318200	3670	3610
TD_/TUC_-U 5040-9-2	50	40	9,525	42,2	2	65500	112500	1400	1380
TD_/TUC_-U 5040-9-3	50	40	9,525	42,2	3	91800	178400	2140	2110
TD_/TUC_-U 5040-9-4	50	40	9,525	42,2	4	119300	248300	2880	2840
TD_/TUC_-U 5050-9-2	50	50	9,525	42,2	2	64200	110700	1360	1340
TD_/TUC_-U 5050-9-3	50	50	9,525	42,2	3	91200	179500	2110	2090
TD_-U 6310-6-2	63	10	6,35	57,5	2	44400	97000	1650	1500
TD_-U 6310-6-3	63	10	6,35	57,5	3	61500	151400	2450	2220
TD_-U 6310-6-4	63	10	6,35	57,5	4	78300	204100	3230	2930
TD_-U 6310-6-5	63	10	6,35	57,5	5	95200	258500	4020	3650
TD_-U 6310-6-6	63	10	6,35	57,5	6	111800	313000	4770	4330
TD_-U 6312-8-2	63	12	7,938	56,3	2	61200	125900	1810	1690
TD_-U 6312-8-3	63	12	7,938	56,3	3	84700	195800	2730	2540
TD_-U 6312-8-4	63	12	7,938	56,3	4	109000	268500	3620	3380
TD_-U 6312-8-5	63	12	7,938	56,3	5	132200	338500	4480	4170
TD_-U 6312-8-6	63	12	7,938	56,3	6	155500	411200	5330	4970
TD_-U 6312-8-7	63	12	7,938	56,3	7	178300	483900	6150	5740
TD_-U 6315-8-2	63	15	7,938	56,3	2	61100	125700	1810	1710
TD_-U 6315-8-3	63	15	7,938	56,3	3	84600	195600	2720	2570
TD_-U 6315-8-4	63	15	7,938	56,3	4	108900	268300	3620	3420
TD_-U 6315-8-5	63	15	7,938	56,3	5	132700	340900	4500	4250
TD_-U 6315-8-6	63	15	7,938	56,3	6	155300	410800	5320	5030
TD_-U 6315-8-7	63	15	7,938	56,3	7	178100	483400	6140	5810
TD_-U 6316-8-2	63	16	7,938	56,3	2	61100	125700	1810	1710
TD_-U 6316-8-3	63	16	7,938	56,3	3	84500	195500	2720	2580
TD_-U 6316-8-4	63	16	7,938	56,3	4	108900	268200	3610	3430
TD_-U 6316-8-5	63	16	7,938	56,3	5	132700	340800	4500	4270
TD_-U 6316-8-6	63	16	7,938	56,3	6	155200	410600	5320	5040
TD_-U 6316-8-7	63	16	7,938	56,3	7	178000	483300	6140	5830
TD_-U 6320-8-2	63	20	7,938	56,3	2	61000	125500	1800	1730
TD_-U 6320-8-3	63	20	7,938	56,3	3	84400	195200	2710	2600
TD_-U 6320-8-4	63	20	7,938	56,3	4	108600	267700	3600	3450
TD_-U 6320-8-5	63	20	7,938	56,3	5	132400	340200	4480	4300

* C_a and C_{oa} : Modified static and dynamic load capacities, calculated according to DIN 69051/4 standard and ISO3408/5. See pages 39 and 43.

** $R_{b/t,pr}$: Rigidity of the balls contact zone for an external force 10% of C_a . See page 47. For a different preload force, multiply by $\sqrt[3]{F_{pr}/0,1 C_a}$

*** R_{nu} : Total rigidity of the complete nut. It must be multiplied by the factor $f_{a'}$, which depends on the manufacturing tolerance. See page 48.

Nut length 1 start	Nut length 2 starts	Nut dimensions										Grease quantity TD 'steel ball'	Grease quantity TUC 'steel ball'	Ball screw reference	
		$D_{1, std}$	$D_{1, min}$	D_4	D_6	M	D_5	L_7	L_1	L_8	L_9				$Q_{gr, real, TD}$ (cm^3)
TDB	TUC														
168	--	90	(85)	108 (103)	125 (120)	M10	11	20	25	95 (90)	110 (105)	24 ~ 35	--	TD_U 5025-9-2	
218	--	90	(85)	108 (103)	125 (120)	M10	11	20	25	95 (90)	110 (105)	30 ~ 45	--	TD_U 5025-9-3	
268	--	90	(85)	108 (103)	125 (120)	M10	11	20	25	95 (90)	110 (105)	36 ~ 55	--	TD_U 5025-9-4	
318	--	90	(85)	108 (103)	125 (120)	M10	11	20	25	95 (90)	110 (105)	43 ~ 65	--	TD_U 5025-9-5	
368	--	90	(85)	108 (103)	125 (120)	M10	11	20	25	95 (90)	110 (105)	50 ~ 74	--	TD_U 5025-9-6	
193	--	90	(85)	108 (103)	125 (120)	M10	11	20	25	95 (90)	110 (105)	26 ~ 39	--	TD_U 5030-9-2	
253	--	90	(85)	108 (103)	125 (120)	M10	11	20	25	95 (90)	110 (105)	33 ~ 50	--	TD_U 5030-9-3	
313	--	90	(85)	108 (103)	125 (120)	M10	11	20	25	95 (90)	110 (105)	41 ~ 62	--	TD_U 5030-9-4	
373	--	90	(85)	108 (103)	125 (120)	M10	11	20	25	95 (90)	110 (105)	49 ~ 73	--	TD_U 5030-9-5	
218	114	90	(85)	108 (103)	125 (120)	M10	11	20	25	95 (90)	110 (105)	26 ~ 39	14 ~ 20	TD_TUC_U 5040-9-2	
298	154	90	(85)	108 (103)	125 (120)	M10	11	20	25	95 (90)	110 (105)	36 ~ 54	19 ~ 29	TD_TUC_U 5040-9-3	
368	194	90	(85)	108 (103)	125 (120)	M10	11	20	25	95 (90)	110 (105)	44 ~ 66	24 ~ 37	TD_TUC_U 5040-9-4	
252	125	90	(85)	108 (103)	125 (120)	M10	11	20	25	95 (90)	110 (105)	29 ~ 43	14 ~ 20	TD_TUC_U 5050-9-2	
352	175	90	(85)	108 (103)	125 (120)	M10	11	20	25	95 (90)	110 (105)	41 ~ 61	20 ~ 30	TD_TUC_U 5050-9-3	
102	--	90		108	125	M10	11	18	16	95	110	15 ~ 22	--	TD_U 6310-6-2	
122	--	90		108	125	M10	11	18	16	95	110	17 ~ 26	--	TD_U 6310-6-3	
142	--	90		108	125	M10	11	18	16	95	110	19 ~ 29	--	TD_U 6310-6-4	
162	--	90		108	125	M10	11	18	16	95	110	21 ~ 32	--	TD_U 6310-6-5	
182	--	90		108	125	M10	11	18	16	95	110	24 ~ 36	--	TD_U 6310-6-6	
116	--	95		115	135	M12	13,5	20	25	100	117,5	22 ~ 32	--	TD_U 6312-8-2	
140	--	95		115	135	M12	13,5	20	25	100	117,5	25 ~ 37	--	TD_U 6312-8-3	
164	--	95		115	135	M12	13,5	20	25	100	117,5	29 ~ 43	--	TD_U 6312-8-4	
188	--	95		115	135	M12	13,5	20	25	100	117,5	32 ~ 48	--	TD_U 6312-8-5	
212	--	95		115	135	M12	13,5	20	25	100	117,5	36 ~ 54	--	TD_U 6312-8-6	
236	--	95		115	135	M12	13,5	20	25	100	117,5	40 ~ 60	--	TD_U 6312-8-7	
135	--	95		115	135	M12	13,5	20	25	100	117,5	23 ~ 34	--	TD_U 6315-8-2	
165	--	95		115	135	M12	13,5	20	25	100	117,5	27 ~ 40	--	TD_U 6315-8-3	
195	--	95		115	135	M12	13,5	20	25	100	117,5	31 ~ 47	--	TD_U 6315-8-4	
225	--	95		115	135	M12	13,5	20	25	100	117,5	35 ~ 53	--	TD_U 6315-8-5	
255	--	95		115	135	M12	13,5	20	25	100	117,5	40 ~ 59	--	TD_U 6315-8-6	
285	--	95		115	135	M12	13,5	20	25	100	117,5	44 ~ 66	--	TD_U 6315-8-7	
140	--	95		115	135	M12	13,5	20	25	100	117,5	23 ~ 35	--	TD_U 6316-8-2	
172	--	95		115	135	M12	13,5	20	25	100	117,5	27 ~ 41	--	TD_U 6316-8-3	
204	--	95		115	135	M12	13,5	20	25	100	117,5	32 ~ 47	--	TD_U 6316-8-4	
236	--	95		115	135	M12	13,5	20	25	100	117,5	36 ~ 54	--	TD_U 6316-8-5	
268	--	95		115	135	M12	13,5	20	25	100	117,5	41 ~ 61	--	TD_U 6316-8-6	
300	--	95		115	135	M12	13,5	20	25	100	117,5	45 ~ 68	--	TD_U 6316-8-7	
164	--	95		115	135	M12	13,5	20	25	100	117,5	25 ~ 37	--	TD_U 6320-8-2	
204	--	95		115	135	M12	13,5	20	25	100	117,5	30 ~ 45	--	TD_U 6320-8-3	
244	--	95		115	135	M12	13,5	20	25	100	117,5	35 ~ 53	--	TD_U 6320-8-4	
284	--	95		115	135	M12	13,5	20	25	100	117,5	40 ~ 60	--	TD_U 6320-8-5	

Key dimensions of the cylindrical nut: N, M, Y are obtained in the tables of page 38 of the catalogue.

SHUTON advises to use the dimensions of the tables, although it is possible to manufacture ball screw with other dimensions.

Smaller nut diameters than the first option of the table can reduce the rigidity of the assembly between 5 and 10%.

Please consult SHUTON.

COMPLEX, Double Nut (1start), Ultracompact Nut

Ball screw reference	Nominal diameter	Lead	Ball diameter	Root diameter	Circuits	Dynamic load capacity	Static load capacity	Rigidity of ball contact zone, with Fpr:10%Ca	Rigidity of nut, with Fpr:10%Ca
TDB Flanged double nut TDL Cylindrical double nut TDBC Centre flanged double nut TUCB Flanged Ultracompact nut TUCL Cylindrical Ultracompact nut	d_0	P_h	D_w	d_2	$i (I_e)$	$C_a(N)$	$C_{oa} (N)$	$R_{b/t,pr} (N/\mu m)$	$R_{nu} (N/\mu m)$
TD_-U 6320-8-6	63	20	7,938	56,3	6	154900	409900	5300	5080
TD_-U 6320-8-7	63	20	7,938	56,3	7	177600	482400	6110	5860
TD_/TUC_-U 6325-8-2	63	25	7,938	56,3	2	60800	125100	1790	1730
TD_/TUC_-U 6325-8-3	63	25	7,938	56,3	3	84900	197400	2730	2640
TD_/TUC_-U 6325-8-4	63	25	7,938	56,3	4	108200	267000	3580	3460
TD_/TUC_-U 6325-8-5	63	25	7,938	56,3	5	131900	339300	4460	4310
TD_/TUC_-U 6325-8-6	63	25	7,938	56,3	6	155000	411600	5300	5130
TD_/TUC_-U 6325-8-7	63	25	7,938	56,3	7	177700	483900	6110	5910
TD_/TUC_-U 6330-8-2	63	30	7,938	56,3	2	60500	124700	1780	1730
TD_/TUC_-U 6330-8-3	63	30	7,938	56,3	3	84500	196800	2710	2640
TD_/TUC_-U 6330-8-4	63	30	7,938	56,3	4	108500	268900	3590	3490
TD_/TUC_-U 6330-8-5	63	30	7,938	56,3	5	132000	340900	4460	4340
TD_/TUC_-U 6330-8-6	63	30	7,938	56,3	6	154400	410200	5270	5120
TD_/TUC_-U 6330-8-7	63	30	7,938	56,3	7	176900	482300	6070	5910
TD_/TUC_-U 6340-8-2	63	40	7,938	56,3	2	60700	126500	1780	1750
TD_/TUC_-U 6340-8-3	63	40	7,938	56,3	3	84400	197900	2700	2640
TD_/TUC_-U 6340-8-4	63	40	7,938	56,3	4	108100	269400	3560	3490
TD_/TUC_-U 6340-8-5	63	40	7,938	56,3	5	131300	340900	4420	4320
TD_/TUC_-U 6340-8-6	63	40	7,938	56,3	6	154100	412400	5240	5130
TD_/TUC_-U 6350-8-2	63	50	7,938	56,3	2	59900	125100	1740	1720
TD_/TUC_-U 6350-8-3	63	50	7,938	56,3	3	83200	195900	2640	2600
TD_/TUC_-U 6350-8-4	63	50	7,938	56,3	4	107400	269300	3520	3460
TD_-B 6312,7-9-2	63	12,7	9,525	55,2	2	76100	145500	1800	1690
TD_-B 6312,7-9-3	63	12,7	9,525	55,2	3	107800	234400	2750	2580
TD_-B 6312,7-9-4	63	12,7	9,525	55,2	4	138200	319300	3650	3430
TD_-B 6312,7-9-5	63	12,7	9,525	55,2	5	169100	408200	4590	4310
TD_-B 6312,7-9-6	63	12,7	9,525	55,2	6	191600	468800	5290	4970
TD_-B 6312,7-9-7	63	12,7	9,525	55,2	7	221300	557700	6220	5840
TD_-B 6312,7-9-8	63	12,7	9,525	55,2	8	248400	638500	7050	6630
TD_-B 6312,7-9-9	63	12,7	9,525	55,2	9	277000	727400	7970	7490
TD_-B 6312,7-9-10	63	12,7	9,525	55,2	10	305200	816300	8880	8340
TD_-B 6312,7-9-11	63	12,7	9,525	55,2	11	325100	872900	9550	8980
TD_-B 6312,7-9-12	63	12,7	9,525	55,2	12	351600	957800	10370	9760
TD_-B 6312,7-9-13	63	12,7	9,525	55,2	13	380800	1054800	11320	10650
TD_-B 6312,7-9-14	63	12,7	9,525	55,2	14	406700	1139600	12240	11510
TD_-B 6312,7-9-15	63	12,7	9,525	55,2	15	432300	1224500	13060	12290
TD_-B 6312,7-9-16	63	12,7	9,525	55,2	16	450200	1277000	13650	12850
TD_-B 6312,7-9-17	63	12,7	9,525	55,2	17	478200	1374000	14680	13810
TD_-U 6316-9-2	63	16	9,525	55,2	2	77400	149400	1840	1760
TD_-U 6316-9-3	63	16	9,525	55,2	3	107700	234100	2740	2620
TD_-U 6316-9-4	63	16	9,525	55,2	4	139100	322900	3690	3520

* C_a and C_{oa} : Modified static and dynamic load capacities, calculated according to DIN 69051/4 standard and ISO3408/5. See pages 39 and 43.

** $R_{b/t,pr}$: Rigidity of the balls contact zone for an external force 10% of C_a . See page 47. For a different preload force, multiply by $\sqrt[3]{F_{pr}/0,1 C_a}$

*** R_{nu} : Total rigidity of the complete nut. It must be multiplied by the factor $f_{a'}$, which depends on the manufacturing tolerance. See page 48.

Nut length 1 start	Nut length 2 starts	Nut dimensions										Grease quantity TD 'steel ball'	Grease quantity TUC 'steel ball'	Ball screw reference
		$D_{1, std}$	$D_{1, min}$	D_4	D_6	M	D_5	L_7	L_1	L_8	L_9			
<i>TDB</i>	<i>TUC</i>											$Q_{gr, real, TD}$ (cm^3)	$Q_{gr, real, TUC}$ (cm^3)	
324	--	95		115	135	M12	13,5	20	25	100	117,5	46 ~ 69	--	TD_U 6320-8-6
364	--	95		115	135	M12	13,5	20	25	100	117,5	51 ~ 77	--	TD_U 6320-8-7
164	89	95		115	135	M12	13,5	20	25	100	117,5	21 ~ 32	13 ~ 19	TD/TUC_U 6325-8-2
214	114	95		115	135	M12	13,5	20	25	100	117,5	27 ~ 41	16 ~ 24	TD/TUC_U 6325-8-3
264	139	95		115	135	M12	13,5	20	25	100	117,5	33 ~ 50	20 ~ 30	TD/TUC_U 6325-8-4
314	164	95		115	135	M12	13,5	20	25	100	117,5	40 ~ 60	23 ~ 35	TD/TUC_U 6325-8-5
364	189	95		115	135	M12	13,5	20	25	100	117,5	46 ~ 69	27 ~ 41	TD/TUC_U 6325-8-6
414	214	95		115	135	M12	13,5	20	25	100	117,5	53 ~ 79	31 ~ 47	TD/TUC_U 6325-8-7
189	91	95		115	135	M12	13,5	20	25	100	117,5	24 ~ 35	11 ~ 16	TD/TUC_U 6330-8-2
249	121	95		115	135	M12	13,5	20	25	100	117,5	30 ~ 46	15 ~ 22	TD/TUC_U 6330-8-3
309	151	95		115	135	M12	13,5	20	25	100	117,5	38 ~ 57	19 ~ 29	TD/TUC_U 6330-8-4
369	181	95		115	135	M12	13,5	20	25	100	117,5	45 ~ 67	23 ~ 35	TD/TUC_U 6330-8-5
429	211	95		115	135	M12	13,5	20	25	100	117,5	53 ~ 79	28 ~ 42	TD/TUC_U 6330-8-6
489	241	95		115	135	M12	13,5	20	25	100	117,5	60 ~ 90	32 ~ 48	TD/TUC_U 6330-8-7
216	109	95		115	135	M12	13,5	20	25	100	117,5	24 ~ 37	12 ~ 18	TD/TUC_U 6340-8-2
296	149	95		115	135	M12	13,5	20	25	100	117,5	33 ~ 50	17 ~ 26	TD/TUC_U 6340-8-3
376	189	95		115	135	M12	13,5	20	25	100	117,5	43 ~ 64	22 ~ 33	TD/TUC_U 6340-8-4
456	229	95		115	135	M12	13,5	20	25	100	117,5	52 ~ 78	28 ~ 41	TD/TUC_U 6340-8-5
536	269	95		115	135	M12	13,5	20	25	100	117,5	61 ~ 92	33 ~ 49	TD/TUC_U 6340-8-6
256	129	95		115	135	M12	13,5	20	25	100	117,5	28 ~ 42	14 ~ 21	TD/TUC_U 6350-8-2
356	179	95		115	135	M12	13,5	20	25	100	117,5	39 ~ 59	20 ~ 30	TD/TUC_U 6350-8-3
456	229	95		115	135	M12	13,5	20	25	100	117,5	50 ~ 76	26 ~ 39	TD/TUC_U 6350-8-4
127	--	100		120	140	M12	13,5	35	25	105	122,5	36 ~ 54	--	TD_B 6312,7-9-2
153	--	100		120	140	M12	13,5	35	25	105	122,5	41 ~ 62	--	TD_B 6312,7-9-3
178	--	100		120	140	M12	13,5	35	25	105	122,5	46 ~ 69	--	TD_B 6312,7-9-4
204	--	100		120	140	M12	13,5	35	25	105	122,5	51 ~ 76	--	TD_B 6312,7-9-5
242	--	100		120	140	M12	13,5	35	25	105	122,5	62 ~ 93	--	TD_B 6312,7-9-6
267	--	100		120	140	M12	13,5	35	25	105	122,5	66 ~ 100	--	TD_B 6312,7-9-7
292	--	100		120	140	M12	13,5	35	25	105	122,5	71 ~ 107	--	TD_B 6312,7-9-8
318	--	100		120	140	M12	13,5	35	25	105	122,5	76 ~ 114	--	TD_B 6312,7-9-9
343	--	100		120	140	M12	13,5	35	25	105	122,5	81 ~ 121	--	TD_B 6312,7-9-10
371	--	100		120	140	M12	13,5	35	25	105	122,5	88 ~ 132	--	TD_B 6312,7-9-11
396	--	100		120	140	M12	13,5	35	25	105	122,5	93 ~ 139	--	TD_B 6312,7-9-12
422	--	100		120	140	M12	13,5	35	25	105	122,5	97 ~ 146	--	TD_B 6312,7-9-13
447	--	100		120	140	M12	13,5	35	25	105	122,5	102 ~ 152	--	TD_B 6312,7-9-14
472	--	100		120	140	M12	13,5	35	25	105	122,5	107 ~ 160	--	TD_B 6312,7-9-15
499	--	100		120	140	M12	13,5	35	25	105	122,5	114 ~ 171	--	TD_B 6312,7-9-16
524	--	100		120	140	M12	13,5	35	25	105	122,5	117 ~ 176	--	TD_B 6312,7-9-17
146	--	105	(100)	125 (120)	145 (140)	M12	13,5	20	25	110 (105)	127,5 (122,5)	32 ~ 48	--	TD_U 6316-9-2
178	--	105	(100)	125 (120)	145 (140)	M12	13,5	20	25	110 (105)	127,5 (122,5)	38 ~ 57	--	TD_U 6316-9-3
210	--	105	(100)	125 (120)	145 (140)	M12	13,5	20	25	110 (105)	127,5 (122,5)	43 ~ 65	--	TD_U 6316-9-4

Key dimensions of the cylindrical nut: N, M, Y are obtained in the tables of page 38 of the catalogue.

SHUTON advises to use the dimensions of the tables, although it is possible to manufacture ball screw with other dimensions.

Smaller nut diameters than the first option of the table can reduce the rigidity of the assembly between 5 and 10%.

Please consult SHUTON.

COMPLEX, Double Nut (1start), Ultracompact Nut

Ball screw reference	Nominal diameter	Lead	Ball diameter	Root diameter	Circuits	Dynamic load capacity	Static load capacity	Rigidity of ball contact zone, with Fpr:10%Ca	Rigidity of nut, with Fpr:10%Ca
TDB Flanged double nut TDL Cylindrical double nut TDBC Centre flanged double nut TUCB Flanged Ultracompact nut TUCL Cylindrical Ultracompact nut	d_0	P_h	D_w	d_2	$i (I_e)$	$C_a(N)$	$C_{oa} (N)$	$R_{b/t,pr} (N/\mu m)$	$R_{nu} (N/\mu m)$
TD_-U 6316-9-5	63	16	9,525	55,2	5	168800	407700	4580	4370
TD_-U 6316-9-6	63	16	9,525	55,2	6	198900	496500	5440	5200
TD_-U 6316-9-7	63	16	9,525	55,2	7	227400	581300	6260	5980
TD_-U 6316-9-8	63	16	9,525	55,2	8	256300	670100	7080	6760
TD_-U 6320-9-2	63	20	9,525	55,2	2	77200	149100	1830	1770
TD_-U 6320-9-3	63	20	9,525	55,2	3	107400	233700	2730	2630
TD_-U 6320-9-4	63	20	9,525	55,2	4	138800	322400	3670	3540
TD_-U 6320-9-5	63	20	9,525	55,2	5	168400	407000	4560	4400
TD_-U 6320-9-6	63	20	9,525	55,2	6	198500	495700	5420	5230
TD_-U 6320-9-7	63	20	9,525	55,2	7	226900	580300	6240	6010
TD_-U 6320-9-8	63	20	9,525	55,2	8	255800	668900	7050	6800
TD_-U/TUC_-B 6325-9-2	63	25	9,525	55,2	2	77000	148700	1820	1770
TD_-U/TUC_-B 6325-9-3	63	25	9,525	55,2	3	107000	233100	2720	2640
TD_-U/TUC_-B 6325-9-4	63	25	9,525	55,2	4	138400	321500	3650	3550
TD_-U/TUC_-B 6325-9-5	63	25	9,525	55,2	5	169000	409900	4580	4440
TD_-U/TUC_-B 6325-9-6	63	25	9,525	55,2	6	197800	494300	5390	5240
TD_-U/TUC_-B 6325-9-7	63	25	9,525	55,2	7	227100	582800	6240	6060
TD_-U/TUC_-B 6325-9-8	63	25	9,525	55,2	8	254900	667200	7020	6810
TD_/TUC_-U 6330-9-2	63	30	9,525	55,2	2	76700	148200	1810	1770
TD_/TUC_-U 6330-9-3	63	30	9,525	55,2	3	107800	236400	2740	2680
TD_/TUC_-U 6330-9-4	63	30	9,525	55,2	4	137800	320500	3630	3540
TD_/TUC_-U 6330-9-5	63	30	9,525	55,2	5	168300	408600	4550	4440
TD_-U 6330-9-6	63	30	9,525	55,2	6	198100	496800	5400	5270
TD_-U 6330-9-7	63	30	9,525	55,2	7	226200	580900	6200	6050
TD_-U 6330-9-8	63	30	9,525	55,2	8	254800	669000	7010	6840
TD_/TUC_-U 6340-9-2	63	40	9,525	55,2	2	75800	147000	1780	1750
TD_/TUC_-U 6340-9-3	63	40	9,525	55,2	3	106700	234400	2700	2650
TD_/TUC_-U 6340-9-4	63	40	9,525	55,2	4	137500	321900	3610	3540
TD_/TUC_-U 6340-9-5	63	40	9,525	55,2	5	167600	409300	4520	4430
TD_-U 6340-9-6	63	40	9,525	55,2	6	197000	496700	5350	5250
TD_/TUC_-U 6350-9-2	63	50	9,525	55,2	2	76200	149500	1790	1760
TD_/TUC_-U 6350-9-3	63	50	9,525	55,2	3	106500	236000	2680	2640
TD_/TUC_-U 6350-9-4	63	50	9,525	55,2	4	136700	322500	3570	3520
TD_-U 6320-11-2	63	20	11,113	54,1	2	93800	172500	1810	1740
TD_-U 6320-11-3	63	20	11,113	54,1	3	131200	272600	2760	2650
TD_-U 6320-11-4	63	20	11,113	54,1	4	170200	378300	3710	3560
TD_-U 6320-11-5	63	20	11,113	54,1	5	208400	484000	4650	4470
TD_-U 6320-11-6	63	20	11,113	54,1	6	244100	584100	5500	5290
TD_-U 6320-11-7	63	20	11,113	54,1	7	280600	689800	6350	6110
TD_-U 6320-11-8	63	20	11,113	54,1	8	314900	790000	7150	6880
TD_-U 6325-11-2	63	25	11,113	54,1	2	93500	172000	1800	1750

* Ca and Coa: Modified static and dynamic load capacities, calculated according to DIN 69051/4 standard and ISO3408/5. See pages 39 and 43.

** Rb/t,pr: Rigidity of the balls contact zone for an external force 10% of Ca. See page 47. For a different preload force, multiply by $\sqrt[3]{F_{pr}/0,1 C_a}$

*** Rnu: Total rigidity of the complete nut. It must be multiplied by the factor f_{ar} , which depends on the manufacturing tolerance. See page 48.

Nut length 1 start	Nut length 2 starts	Nut dimensions										Grease quantity TD 'steel ball'	Grease quantity TUC 'steel ball'	Ball screw reference	
		$D_{1,std}$	$D_{1,min}$	D_4	D_6	M	D_5	L_7	L_1	L_8	L_9				$Q_{gr,real,TD}$ (cm^3)
TDB	TUC														
242	--	105	(100)	125 (120)	145 (140)	M12	13,5	20	25	110 (105)	127,5 (122,5)	49 ~ 74	--	TD_U 6316-9-5	
274	--	105	(100)	125 (120)	145 (140)	M12	13,5	20	25	110 (105)	127,5 (122,5)	55 ~ 83	--	TD_U 6316-9-6	
306	--	105	(100)	125 (120)	145 (140)	M12	13,5	20	25	110 (105)	127,5 (122,5)	62 ~ 92	--	TD_U 6316-9-7	
338	--	105	(100)	125 (120)	145 (140)	M12	13,5	20	25	110 (105)	127,5 (122,5)	68 ~ 102	--	TD_U 6316-9-8	
169	--	105	(100)	125 (120)	145 (140)	M12	13,5	20	25	110 (105)	127,5 (122,5)	34 ~ 51	--	TD_U 6320-9-2	
209	--	105	(100)	125 (120)	145 (140)	M12	13,5	20	25	110 (105)	127,5 (122,5)	41 ~ 61	--	TD_U 6320-9-3	
249	--	105	(100)	125 (120)	145 (140)	M12	13,5	20	25	110 (105)	127,5 (122,5)	47 ~ 71	--	TD_U 6320-9-4	
289	--	105	(100)	125 (120)	145 (140)	M12	13,5	20	25	110 (105)	127,5 (122,5)	54 ~ 82	--	TD_U 6320-9-5	
329	--	105	(100)	125 (120)	145 (140)	M12	13,5	20	25	110 (105)	127,5 (122,5)	62 ~ 92	--	TD_U 6320-9-6	
369	--	105	(100)	125 (120)	145 (140)	M12	13,5	20	25	110 (105)	127,5 (122,5)	69 ~ 104	--	TD_U 6320-9-7	
409	--	105	(100)	125 (120)	145 (140)	M12	13,5	20	25	110 (105)	127,5 (122,5)	77 ~ 115	--	TD_U 6320-9-8	
172	92	105	(100)	125 (120)	145 (140)	M12	13,5	20	25	110 (105)	127,5 (122,5)	30 ~ 45	22 ~ 33	TD_U/TUC_-B 6325-9-2	
222	117	105	(100)	125 (120)	145 (140)	M12	13,5	20	25	110 (105)	127,5 (122,5)	38 ~ 57	27 ~ 40	TD_U/TUC_-B 6325-9-3	
272	142	105	(100)	125 (120)	145 (140)	M12	13,5	20	25	110 (105)	127,5 (122,5)	46 ~ 69	31 ~ 47	TD_U/TUC_-B 6325-9-4	
322	167	105	(100)	125 (120)	145 (140)	M12	13,5	20	25	110 (105)	127,5 (122,5)	54 ~ 81	36 ~ 54	TD_U/TUC_-B 6325-9-5	
372	204	105	(100)	125 (120)	145 (140)	M12	13,5	20	25	110 (105)	127,5 (122,5)	63 ~ 94	47 ~ 71	TD_U/TUC_-B 6325-9-6	
422	229	105	(100)	125 (120)	145 (140)	M12	13,5	20	25	110 (105)	127,5 (122,5)	71 ~ 107	52 ~ 78	TD_U/TUC_-B 6325-9-7	
472	254	105	(100)	125 (120)	145 (140)	M12	13,5	20	25	110 (105)	127,5 (122,5)	81 ~ 121	56 ~ 85	TD_U/TUC_-B 6325-9-8	
196	104	105	(100)	125 (120)	145 (140)	M12	13,5	20	25	110 (105)	127,5 (122,5)	33 ~ 49	18 ~ 27	TD_/TUC_-U 6330-9-2	
256	134	105	(100)	125 (120)	145 (140)	M12	13,5	20	25	110 (105)	127,5 (122,5)	42 ~ 63	23 ~ 35	TD_/TUC_-U 6330-9-3	
316	164	105	(100)	125 (120)	145 (140)	M12	13,5	20	25	110 (105)	127,5 (122,5)	52 ~ 77	29 ~ 43	TD_/TUC_-U 6330-9-4	
376	194	105	(100)	125 (120)	145 (140)	M12	13,5	20	25	110 (105)	127,5 (122,5)	61 ~ 91	34 ~ 51	TD_/TUC_-U 6330-9-5	
436	--	105	(100)	125 (120)	145 (140)	M12	13,5	20	25	110 (105)	127,5 (122,5)	71 ~ 106	--	TD_U 6330-9-6	
496	--	105	(100)	125 (120)	145 (140)	M12	13,5	20	25	110 (105)	127,5 (122,5)	81 ~ 122	--	TD_U 6330-9-7	
539	--	105	(100)	125 (120)	145 (140)	M12	13,5	20	25	110 (105)	127,5 (122,5)	87 ~ 131	--	TD_U 6330-9-8	
222	115	105	(100)	125 (120)	145 (140)	M12	13,5	20	25	110 (105)	127,5 (122,5)	34 ~ 50	17 ~ 26	TD_/TUC_-U 6340-9-2	
302	155	105	(100)	125 (120)	145 (140)	M12	13,5	20	25	110 (105)	127,5 (122,5)	46 ~ 69	24 ~ 36	TD_/TUC_-U 6340-9-3	
382	195	105	(100)	125 (120)	145 (140)	M12	13,5	20	25	110 (105)	127,5 (122,5)	58 ~ 87	31 ~ 46	TD_/TUC_-U 6340-9-4	
462	235	105	(100)	125 (120)	145 (140)	M12	13,5	20	25	110 (105)	127,5 (122,5)	70 ~ 105	37 ~ 56	TD_/TUC_-U 6340-9-5	
532	--	105	(100)	125 (120)	145 (140)	M12	13,5	20	25	110 (105)	127,5 (122,5)	80 ~ 121	--	TD_U 6340-9-6	
256	127	105	(100)	125 (120)	145 (140)	M12	13,5	20	25	110 (105)	127,5 (122,5)	37 ~ 55	17 ~ 26	TD_/TUC_-U 6350-9-2	
356	177	105	(100)	125 (120)	145 (140)	M12	13,5	20	25	110 (105)	127,5 (122,5)	52 ~ 78	25 ~ 38	TD_/TUC_-U 6350-9-3	
456	227	105	(100)	125 (120)	145 (140)	M12	13,5	20	25	110 (105)	127,5 (122,5)	67 ~ 100	33 ~ 50	TD_/TUC_-U 6350-9-4	
158	--	105		125	145	M12	13,5	25	25	110	127,5	41 ~ 62	--	TD_U 6320-11-2	
198	--	105		125	145	M12	13,5	25	25	110	127,5	49 ~ 74	--	TD_U 6320-11-3	
238	--	105		125	145	M12	13,5	25	25	110	127,5	58 ~ 87	--	TD_U 6320-11-4	
278	--	105		125	145	M12	13,5	25	25	110	127,5	66 ~ 99	--	TD_U 6320-11-5	
318	--	105		125	145	M12	13,5	25	25	110	127,5	75 ~ 113	--	TD_U 6320-11-6	
358	--	105		125	145	M12	13,5	25	25	110	127,5	85 ~ 127	--	TD_U 6320-11-7	
398	--	105		125	145	M12	13,5	25	25	110	127,5	94 ~ 141	--	TD_U 6320-11-8	
174	--	105		125	145	M12	13,5	25	25	110	127,5	41 ~ 61	--	TD_U 6325-11-2	

Key dimensions of the cylindrical nut: N, M, Y are obtained in the tables of page 38 of the catalogue.

SHUTON advises to use the dimensions of the tables, although it is possible to manufacture ball screw with other dimensions.

Smaller nut diameters than the first option of the table can reduce the rigidity of the assembly between 5 and 10%.

Please consult SHUTON.

COMPLEX, Double Nut (1start), Ultracompact Nut

Ball screw reference	Nominal diameter	Lead	Ball diameter	Root diameter	Circuits	Dynamic load capacity	Static load capacity	Rigidity of ball contact zone, with Fpr:10%Ca	Rigidity of nut, with Fpr:10%Ca
TDB Flanged double nut TDL Cylindrical double nut TDBC Centre flanged double nut TUCB Flanged Ultracompact nut TUCL Cylindrical Ultracompact nut	d_0	P_h	D_w	d_2	$i (I_e)$	$C_a(N)$	$C_{oa} (N)$	$R_{b/t,pr} (N/\mu m)$	$R_{nu} (N/\mu m)$
TD_-U 6325-11-3	63	25	11,113	54,1	3	130700	271900	2740	2660
TD_-U 6325-11-4	63	25	11,113	54,1	4	169700	377300	3690	3570
TD_-U 6325-11-5	63	25	11,113	54,1	5	207700	482700	4620	4480
TD_-U 6325-11-6	63	25	11,113	54,1	6	243300	582600	5470	5300
TD_-U 6325-11-7	63	25	11,113	54,1	7	279700	688000	6310	6120
TD_-U 6325-11-8	63	25	11,113	54,1	8	315300	793400	7160	6940
TD_-U 6330-11-2	63	30	11,113	54,1	2	93100	171500	1790	1740
TD_-U 6330-11-3	63	30	11,113	54,1	3	132000	276500	2770	2700
TD_-U 6330-11-4	63	30	11,113	54,1	4	169000	376100	3660	3570
TD_-U 6330-11-5	63	30	11,113	54,1	5	206800	481200	4590	4470
TD_-U 6330-11-6	63	30	11,113	54,1	6	243800	586300	5480	5340
TD_-U 6330-11-7	63	30	11,113	54,1	7	280000	691400	6320	6160
TD_-U 6330-11-8	63	30	11,113	54,1	8	314000	790900	7110	6930
TD_-U 6340-11-2	63	40	11,113	54,1	2	92100	170100	1760	1730
TD_-U 6340-11-3	63	40	11,113	54,1	3	130600	274300	2730	2670
TD_-U 6340-11-4	63	40	11,113	54,1	4	168800	378600	3650	3580
TD_-U 6340-11-5	63	40	11,113	54,1	5	206200	482800	4560	4480
TD_-U 6340-11-6	63	40	11,113	54,1	6	242800	587100	5440	5330
TD_-U 6350-11-2	63	50	11,113	54,1	2	92900	173800	1770	1750
TD_-U 6350-11-3	63	50	11,113	54,1	3	130600	277000	2720	2680
TD_-U 6350-11-4	63	50	11,113	54,1	4	168200	380200	3620	3570
TD_-B 6316-12-2	63	16	12,7	54	2	111000	196500	1880	1800
TD_-B 6316-12-3	63	16	12,7	54	3	156000	313000	2890	2750
TD_-B 6316-12-4	63	16	12,7	54	4	203200	436700	3940	3760
TD_-B 6316-12-5	63	16	12,7	54	5	249200	560400	4950	4720
TD_-B 6316-12-6	63	16	12,7	54	6	292100	676900	5830	5570
TD_-B 6316-12-7	63	16	12,7	54	7	336100	800600	6780	6460
TD_-B 6316-12-8	63	16	12,7	54	8	365300	873400	7610	7270
TD_-B 6316-12-9	63	16	12,7	54	9	406000	989800	8530	8150
TD_-B 6316-12-10	63	16	12,7	54	10	450000	1120800	9560	9130
TD_-B 6316-12-11	63	16	12,7	54	11	489500	1237300	10380	9920
TD_-B 6316-12-12	63	16	12,7	54	12	528500	1353700	11280	10780
TD_-B 6316-12-13	63	16	12,7	54	13	570700	1484700	12210	11670
TD_-B 6316-12-14	63	16	12,7	54	14	608800	1601200	13110	12530
TD_-B 6320-15-2	63	20	15,875	50	2	143700	234900	1730	1670
TD_-B 6320-15-3	63	20	15,875	50	3	206800	387500	2710	2620
TD_-B 6320-15-4	63	20	15,875	50	4	269100	540200	3620	3500
TD_-B 6320-15-5	63	20	15,875	50	5	330000	692800	4580	4420
TD_-B 6320-15-6	63	20	15,875	50	6	393000	857200	5550	5360
TD_-B 6320-15-7	63	20	15,875	50	7	451000	1009900	6390	6160
TD_-B 6320-15-8	63	20	15,875	50	8	507900	1162500	7220	6970

* Ca and Coa: Modified static and dynamic load capacities, calculated according to DIN 69051/4 standard and ISO3408/5. See pages 39 and 43.

** Rb/t,pr: Rigidity of the balls contact zone for an external force 10% of Ca. See page 47. For a different preload force, multiply by $\sqrt[3]{F_{pr}/0,1 C_a}$

*** Rnu: Total rigidity of the complete nut. It must be multiplied by the factor $f_{a'}$, which depends on the manufacturing tolerance. See page 48.

Nut length 1 start	Nut length 2 starts	Nut dimensions										Grease quantity TD 'steel ball'	Grease quantity TUC 'steel ball'	Ball screw reference
		$D_{1, std}$	$D_{1, min}$	D_4	D_6	M	D_5	L_7	L_1	L_8	L_9			
TDB	TUC											$Q_{gr, real, TD}$ (cm^3)	$Q_{gr, real, TUC}$ (cm^3)	
224	--	105		125	145	M12	13,5	25	25	110	127,5	51 ~ 76	--	TD_U 6325-11-3
274	--	105		125	145	M12	13,5	25	25	110	127,5	61 ~ 91	--	TD_U 6325-11-4
324	--	105		125	145	M12	13,5	25	25	110	127,5	71 ~ 106	--	TD_U 6325-11-5
374	--	105		125	145	M12	13,5	25	25	110	127,5	82 ~ 123	--	TD_U 6325-11-6
424	--	105		125	145	M12	13,5	25	25	110	127,5	93 ~ 139	--	TD_U 6325-11-7
474	--	105		125	145	M12	13,5	25	25	110	127,5	104 ~ 156	--	TD_U 6325-11-8
194	--	105		125	145	M12	13,5	25	25	110	127,5	43 ~ 64	--	TD_U 6330-11-2
254	--	105		125	145	M12	13,5	25	25	110	127,5	54 ~ 81	--	TD_U 6330-11-3
314	--	105		125	145	M12	13,5	25	25	110	127,5	66 ~ 99	--	TD_U 6330-11-4
374	--	105		125	145	M12	13,5	25	25	110	127,5	78 ~ 117	--	TD_U 6330-11-5
434	--	105		125	145	M12	13,5	25	25	110	127,5	90 ~ 135	--	TD_U 6330-11-6
494	--	105		125	145	M12	13,5	25	25	110	127,5	103 ~ 154	--	TD_U 6330-11-7
539	--	105		125	145	M12	13,5	25	25	110	127,5	111 ~ 167	--	TD_U 6330-11-8
224	--	105		125	145	M12	13,5	25	25	110	127,5	45 ~ 67	--	TD_U 6340-11-2
304	--	105		125	145	M12	13,5	25	25	110	127,5	59 ~ 89	--	TD_U 6340-11-3
384	--	105		125	145	M12	13,5	25	25	110	127,5	75 ~ 112	--	TD_U 6340-11-4
464	--	105		125	145	M12	13,5	25	25	110	127,5	90 ~ 135	--	TD_U 6340-11-5
538	--	105		125	145	M12	13,5	25	25	110	127,5	104 ~ 156	--	TD_U 6340-11-6
256	--	105		125	145	M12	13,5	25	25	110	127,5	48 ~ 72	--	TD_U 6350-11-2
356	--	105		125	145	M12	13,5	25	25	110	127,5	66 ~ 100	--	TD_U 6350-11-3
456	--	105		125	145	M12	13,5	25	25	110	127,5	85 ~ 128	--	TD_U 6350-11-4
144	--	110		130	150	M12	13,5	40	25	115	132,5	56 ~ 84	--	TD_B 6316-12-2
176	--	110		130	150	M12	13,5	40	25	115	132,5	64 ~ 96	--	TD_B 6316-12-3
208	--	110		130	150	M12	13,5	40	25	115	132,5	71 ~ 106	--	TD_B 6316-12-4
240	--	110		130	150	M12	13,5	40	25	115	132,5	79 ~ 118	--	TD_B 6316-12-5
272	--	110		130	150	M12	13,5	40	25	115	132,5	88 ~ 132	--	TD_B 6316-12-6
304	--	110		130	150	M12	13,5	40	25	115	132,5	96 ~ 144	--	TD_B 6316-12-7
352	--	110		130	150	M12	13,5	40	25	115	132,5	114 ~ 171	--	TD_B 6316-12-8
384	--	110		130	150	M12	13,5	40	25	115	132,5	122 ~ 184	--	TD_B 6316-12-9
416	--	110		130	150	M12	13,5	40	25	115	132,5	129 ~ 194	--	TD_B 6316-12-10
448	--	110		130	150	M12	13,5	40	25	115	132,5	139 ~ 209	--	TD_B 6316-12-11
480	--	110		130	150	M12	13,5	40	25	115	132,5	148 ~ 222	--	TD_B 6316-12-12
512	--	110		130	150	M12	13,5	40	25	115	132,5	156 ~ 234	--	TD_B 6316-12-13
532	--	110		130	150	M12	13,5	40	25	115	132,5	158 ~ 237	--	TD_B 6316-12-14
175	--	120		140	160	M12	13,5	45	25	125	142,5	91 ~ 136	--	TD_B 6320-15-2
215	--	120		140	160	M12	13,5	45	25	125	142,5	103 ~ 155	--	TD_B 6320-15-3
255	--	120		140	160	M12	13,5	45	25	125	142,5	118 ~ 176	--	TD_B 6320-15-4
295	--	120		140	160	M12	13,5	45	25	125	142,5	130 ~ 195	--	TD_B 6320-15-5
335	--	120		140	160	M12	13,5	45	25	125	142,5	143 ~ 215	--	TD_B 6320-15-6
375	--	120		140	160	M12	13,5	45	25	125	142,5	159 ~ 238	--	TD_B 6320-15-7
415	--	120		140	160	M12	13,5	45	25	125	142,5	174 ~ 261	--	TD_B 6320-15-8

Key dimensions of the cylindrical nut: N, M, Y are obtained in the tables of page 38 of the catalogue.

SHUTON advises to use the dimensions of the tables, although it is possible to manufacture ball screw with other dimensions.

Smaller nut diameters than the first option of the table can reduce the rigidity of the assembly between 5 and 10%.

Please consult SHUTON.

COMPLEX, Double Nut (1start), Ultracompact Nut

Ball screw reference	Nominal diameter	Lead	Ball diameter	Root diameter	Circuits	Dynamic load capacity	Static load capacity	Rigidity of ball contact zone, with Fpr:10%Ca	Rigidity of nut, with Fpr:10%Ca
TDB Flanged double nut TDL Cylindrical double nut TDBC Centre flanged double nut TUCB Flanged Ultracompact nut TUCL Cylindrical Ultracompact nut	d_0	P_h	D_w	d_2	$i (I_e)$	$C_a(N)$	$C_{oa} (N)$	$R_{b/t,pr} (N/\mu m)$	$R_{nu} (N/\mu m)$
TD_-B 6320-15-9	63	20	15,875	50	9	563900	1315200	7990	7710
TD_-B 6320-15-10	63	20	15,875	50	10	595700	1385600	8860	8560
TD_-U 7010-6-2	70	10	6,35	64,5	2	46900	109300	1810	1640
TD_-U 7010-6-3	70	10	6,35	64,5	3	64600	169100	2690	2450
TD_-U 7010-6-4	70	10	6,35	64,5	4	82500	228800	3560	3240
TD_-U 7010-6-5	70	10	6,35	64,5	5	100000	288600	4380	3990
TD_-U 7012-8-2	70	12	7,938	63,3	2	64400	140500	1990	1840
TD_-U 7012-8-3	70	12	7,938	63,3	3	90100	222000	3010	2780
TD_-U 7012-8-4	70	12	7,938	63,3	4	115000	300700	3960	3670
TD_-U 7012-8-5	70	12	7,938	63,3	5	139500	379400	4910	4550
TD_-U 7012-8-6	70	12	7,938	63,3	6	164100	460900	5860	5430
TD_-U 7015-8-2	70	15	7,938	63,3	2	64400	140400	1980	1870
TD_-U 7015-8-3	70	15	7,938	63,3	3	90000	221800	3000	2820
TD_-U 7015-8-4	70	15	7,938	63,3	4	114900	300500	3960	3720
TD_-U 7015-8-5	70	15	7,938	63,3	5	139300	379100	4900	4610
TD_-U 7015-8-6	70	15	7,938	63,3	6	163900	460500	5850	5500
TD_-U 7016-8-2	70	16	7,938	63,3	2	64300	140400	1980	1870
TD_-U 7016-8-3	70	16	7,938	63,3	3	89900	221800	3000	2830
TD_-U 7016-8-4	70	16	7,938	63,3	4	114800	300400	3950	3730
TD_-U 7016-8-5	70	16	7,938	63,3	5	139300	379000	4900	4630
TD_-U 7016-8-6	70	16	7,938	63,3	6	163800	460400	5840	5520
TD_-U 7020-8-2	70	20	7,938	63,3	2	64200	140200	1980	1890
TD_-U 7020-8-3	70	20	7,938	63,3	3	89800	221500	2990	2860
TD_-U 7020-8-4	70	20	7,938	63,3	4	114600	299900	3940	3760
TD_-U 7020-8-5	70	20	7,938	63,3	5	139700	381200	4920	4700
TD_-U 7020-8-6	70	20	7,938	63,3	6	163500	459700	5830	5570
TD_/TUC_-U 7025-8-2	70	25	7,938	63,3	2	64000	139800	1970	1900
TD_/TUC_-U 7025-8-3	70	25	7,938	63,3	3	89500	221000	2980	2870
TD_/TUC_-U 7025-8-4	70	25	7,938	63,3	4	114300	299300	3920	3780
TD_/TUC_-U 7025-8-5	70	25	7,938	63,3	5	139300	380400	4900	4720
TD_/TUC_-U 7025-8-6	70	25	7,938	63,3	6	163100	458700	5800	5590
TD_/TUC_-U 7030-8-2	70	30	7,938	63,3	2	64700	142300	1990	1930
TD_/TUC_-U 7030-8-3	70	30	7,938	63,3	3	89200	220400	2960	2870
TD_/TUC_-U 7030-8-4	70	30	7,938	63,3	4	114600	301300	3940	3810
TD_/TUC_-U 7030-8-5	70	30	7,938	63,3	5	138800	379400	4870	4720
TD_/TUC_-U 7030-8-6	70	30	7,938	63,3	6	163200	460300	5800	5630
TD_/TUC_-U 7040-8-2	70	40	7,938	63,3	2	64100	141300	1970	1920
TD_/TUC_-U 7040-8-3	70	40	7,938	63,3	3	89200	221700	2950	2890
TD_/TUC_-U 7040-8-4	70	40	7,938	63,3	4	113600	299200	3880	3790
TD_/TUC_-U 7040-8-5	70	40	7,938	63,3	5	138300	379600	4830	4720
TD_/TUC_-U 7040-8-6	70	40	7,938	63,3	6	162400	459900	5750	5620

* C_a and C_{oa} : Modified static and dynamic load capacities, calculated according to DIN 69051/4 standard and ISO3408/5. See pages 39 and 43.

** $R_{b/t,pr}$: Rigidity of the balls contact zone for an external force 10% of C_a . See page 47. For a different preload force, multiply by $\sqrt[3]{F_{pr}/0,1 C_a}$

*** R_{nu} : Total rigidity of the complete nut. It must be multiplied by the factor f_{at} , which depends on the manufacturing tolerance. See page 48.

Nut length 1 start	Nut length 2 starts	Nut dimensions										Grease quantity TD 'steel ball'	Grease quantity TUC 'steel ball'	Ball screw reference	
		$D_{1, std}$	$D_{1, min}$	D_4	D_6	M	D_5	L_7	L_1	L_8	L_9				$Q_{gr, real, TD}$ (cm^3)
TDB	TUC														
455	--	120		140	160	M12	13,5	45	25	125	142,5	191 ~ 286	--	TD_-B 6320-15-9	
515	--	120		140	160	M12	13,5	45	25	125	142,5	217 ~ 326	--	TD_-B 6320-15-10	
102	--	105	(95)	123 (113)	140 (130)	M10	11	20	25	110 (100)	125 (115)	16 ~ 25	--	TD_-U 7010-6-2	
122	--	105	(95)	123 (113)	140 (130)	M10	11	20	25	110 (100)	125 (115)	19 ~ 28	--	TD_-U 7010-6-3	
142	--	105	(95)	123 (113)	140 (130)	M10	11	20	25	110 (100)	125 (115)	21 ~ 32	--	TD_-U 7010-6-4	
162	--	105	(95)	123 (113)	140 (130)	M10	11	20	25	110 (100)	125 (115)	24 ~ 36	--	TD_-U 7010-6-5	
128	--	105		125	145	M12	13,5	20	25	110	127,5	28 ~ 42	--	TD_-U 7012-8-2	
152	--	105		125	145	M12	13,5	20	25	110	127,5	32 ~ 48	--	TD_-U 7012-8-3	
177	--	105		125	145	M12	13,5	20	25	110	127,5	36 ~ 54	--	TD_-U 7012-8-4	
200	--	105		125	145	M12	13,5	20	25	110	127,5	40 ~ 60	--	TD_-U 7012-8-5	
225	--	105		125	145	M12	13,5	20	25	110	127,5	44 ~ 66	--	TD_-U 7012-8-6	
133	--	105		125	145	M12	13,5	20	25	110	127,5	25 ~ 37	--	TD_-U 7015-8-2	
163	--	105		125	145	M12	13,5	20	25	110	127,5	29 ~ 44	--	TD_-U 7015-8-3	
193	--	105		125	145	M12	13,5	20	25	110	127,5	34 ~ 51	--	TD_-U 7015-8-4	
225	--	105		125	145	M12	13,5	20	25	110	127,5	38 ~ 58	--	TD_-U 7015-8-5	
253	--	105		125	145	M12	13,5	20	25	110	127,5	43 ~ 65	--	TD_-U 7015-8-6	
139	--	105		125	145	M12	13,5	20	25	110	127,5	25 ~ 38	--	TD_-U 7016-8-2	
171	--	105		125	145	M12	13,5	20	25	110	127,5	30 ~ 45	--	TD_-U 7016-8-3	
203	--	105		125	145	M12	13,5	20	25	110	127,5	35 ~ 52	--	TD_-U 7016-8-4	
237	--	105		125	145	M12	13,5	20	25	110	127,5	40 ~ 59	--	TD_-U 7016-8-5	
269	--	105		125	145	M12	13,5	20	25	110	127,5	44 ~ 67	--	TD_-U 7016-8-6	
162	--	105		125	145	M12	13,5	20	25	110	127,5	27 ~ 40	--	TD_-U 7020-8-2	
202	--	105		125	145	M12	13,5	20	25	110	127,5	32 ~ 49	--	TD_-U 7020-8-3	
242	--	105		125	145	M12	13,5	20	25	110	127,5	38 ~ 57	--	TD_-U 7020-8-4	
282	--	105		125	145	M12	13,5	20	25	110	127,5	44 ~ 66	--	TD_-U 7020-8-5	
322	--	105		125	145	M12	13,5	20	25	110	127,5	50 ~ 75	--	TD_-U 7020-8-6	
164	87	105		125	145	M12	13,5	20	25	110	127,5	23 ~ 35	13 ~ 20	TD_/TUC_-U 7025-8-2	
214	112	105		125	145	M12	13,5	20	25	110	127,5	30 ~ 45	17 ~ 26	TD_/TUC_-U 7025-8-3	
264	137	105		125	145	M12	13,5	20	25	110	127,5	37 ~ 56	21 ~ 32	TD_/TUC_-U 7025-8-4	
314	162	105		125	145	M12	13,5	20	25	110	127,5	44 ~ 66	25 ~ 38	TD_/TUC_-U 7025-8-5	
364	187	105		125	145	M12	13,5	20	25	110	127,5	51 ~ 76	29 ~ 44	TD_/TUC_-U 7025-8-6	
190	92	105		125	145	M12	13,5	20	25	110	127,5	26 ~ 39	12 ~ 18	TD_/TUC_-U 7030-8-2	
250	122	105		125	145	M12	13,5	20	25	110	127,5	34 ~ 51	17 ~ 25	TD_/TUC_-U 7030-8-3	
310	152	105		125	145	M12	13,5	20	25	110	127,5	42 ~ 63	21 ~ 32	TD_/TUC_-U 7030-8-4	
370	182	105		125	145	M12	13,5	20	25	110	127,5	50 ~ 75	26 ~ 39	TD_/TUC_-U 7030-8-5	
430	212	105		125	145	M12	13,5	20	25	110	127,5	58 ~ 87	31 ~ 46	TD_/TUC_-U 7030-8-6	
218	110	105		125	145	M12	13,5	20	25	110	127,5	27 ~ 41	14 ~ 20	TD_/TUC_-U 7040-8-2	
298	150	105		125	145	M12	13,5	20	25	110	127,5	37 ~ 56	19 ~ 29	TD_/TUC_-U 7040-8-3	
378	190	105		125	145	M12	13,5	20	25	110	127,5	48 ~ 72	25 ~ 38	TD_/TUC_-U 7040-8-4	
458	230	105		125	145	M12	13,5	20	25	110	127,5	58 ~ 87	31 ~ 46	TD_/TUC_-U 7040-8-5	
538	270	105		125	145	M12	13,5	20	25	110	127,5	68 ~ 103	37 ~ 55	TD_/TUC_-U 7040-8-6	

Key dimensions of the cylindrical nut: N, M, Y are obtained in the tables of page 38 of the catalogue.

SHUTON advises to use the dimensions of the tables, although it is possible to manufacture ball screw with other dimensions.

Smaller nut diameters than the first option of the table can reduce the rigidity of the assembly between 5 and 10%.

Please consult SHUTON.

COMPLEX, Double Nut (1start), Ultracompact Nut

Ball screw reference	Nominal diameter	Lead	Ball diameter	Root diameter	Circuits	Dynamic load capacity	Static load capacity	Rigidity of ball contact zone, with Fpr:10%Ca	Rigidity of nut, with Fpr:10%Ca
TDB Flanged double nut TDL Cylindrical double nut TDBC Centre flanged double nut TUCB Flanged Ultracompact nut TUCL Cylindrical Ultracompact nut	d_0	P_h	D_w	d_2	$i (I_e)$	$C_a(N)$	$C_{oa} (N)$	$R_{b/t,pr} (N/\mu m)$	$R_{nu} (N/\mu m)$
TD_/TUC_-U 7050-8-2	70	50	7,938	63,3	2	63400	140100	1930	1900
TD_/TUC_-U 7050-8-3	70	50	7,938	63,3	3	88200	219800	2900	2850
TD_/TUC_-U 7050-8-4	70	50	7,938	63,3	4	113000	299400	3840	3770
TD_-B 7012,7-9-2	70	12,7	9,525	62,2	2	81700	166600	2020	1880
TD_-B 7012,7-9-3	70	12,7	9,525	62,2	3	114500	264200	3050	2840
TD_-B 7012,7-9-4	70	12,7	9,525	62,2	4	147200	361700	4070	3790
TD_-B 7012,7-9-5	70	12,7	9,525	62,2	5	178200	455200	5010	4670
TD_-B 7012,7-9-6	70	12,7	9,525	62,2	6	203400	528300	5860	5470
TD_-B 7012,7-9-7	70	12,7	9,525	62,2	7	234300	625900	6860	6400
TD_-B 7012,7-9-8	70	12,7	9,525	62,2	8	264600	723400	7850	7330
TD_-B 7012,7-9-9	70	12,7	9,525	62,2	9	294400	820900	8780	8200
TD_-B 7012,7-9-10	70	12,7	9,525	62,2	10	321800	910300	9680	9040
TD_-B 7012,7-9-11	70	12,7	9,525	62,2	11	346000	987600	10510	9830
TD_-B 7012,7-9-12	70	12,7	9,525	62,2	12	374600	1085100	11550	10800
TD_-B 7012,7-9-13	70	12,7	9,525	62,2	13	402800	1182600	12490	11680
TD_-B 7012,7-9-14	70	12,7	9,525	62,2	14	430800	1280200	13430	12560
TD_-B 7012,7-9-15	70	12,7	9,525	62,2	15	455700	1365500	14240	13320
TD_-B 7012,7-9-16	70	12,7	9,525	62,2	16	479600	1446800	15190	14220
TD_-U 7016-9-2	70	16	9,525	62,2	2	81600	166500	2020	1910
TD_-U 7016-9-3	70	16	9,525	62,2	3	114300	263900	3040	2870
TD_-U 7016-9-4	70	16	9,525	62,2	4	147000	361400	4060	3840
TD_-U 7016-9-5	70	16	9,525	62,2	5	179100	458800	5040	4760
TD_-U 7016-9-6	70	16	9,525	62,2	6	209400	552200	5940	5620
TD_-U 7016-9-7	70	16	9,525	62,2	7	240100	649600	6840	6480
TD_-U 7016-9-8	70	16	9,525	62,2	8	270200	747100	7730	7330
TD_-U 7020-9-2	70	20	9,525	62,2	2	81400	166200	2010	1920
TD_-U 7020-9-3	70	20	9,525	62,2	3	114100	263500	3030	2900
TD_-U 7020-9-4	70	20	9,525	62,2	4	146800	360900	4050	3870
TD_-U 7020-9-5	70	20	9,525	62,2	5	178800	458200	5020	4800
TD_-U 7020-9-6	70	20	9,525	62,2	6	210000	555500	5960	5700
TD_-U 7020-9-7	70	20	9,525	62,2	7	239600	648700	6820	6530
TD_-U 7020-9-8	70	20	9,525	62,2	8	269700	746000	7710	7380
TD_-U/TUC_-B 7025-9-2	70	25	9,525	62,2	2	81200	165900	2000	1930
TD_-U/TUC_-B 7025-9-3	70	25	9,525	62,2	3	113800	263000	3020	2910
TD_-U/TUC_-B 7025-9-4	70	25	9,525	62,2	4	146400	360100	4030	3890
TD_-U/TUC_-B 7025-9-5	70	25	9,525	62,2	5	178200	457200	5000	4820
TD_-U/TUC_-B 7025-9-6	70	25	9,525	62,2	6	209400	554300	5930	5730
TD_-U/TUC_-B 7025-9-7	70	25	9,525	62,2	7	240000	651400	6830	6590
TD_-U/TUC_-B 7025-9-8	70	25	9,525	62,2	8	269900	748500	7720	7450
TD_/TUC_-U 7030-9-2	70	30	9,525	62,2	2	80900	165400	1990	1930
TD_/TUC_-U 7030-9-3	70	30	9,525	62,2	3	113400	262300	3000	2910

* C_a and C_{oa} : Modified static and dynamic load capacities, calculated according to DIN 69051/4 standard and ISO3408/5. See pages 39 and 43.

** $R_{b/t,pr}$: Rigidity of the balls contact zone for an external force 10% of C_a . See page 47. For a different preload force, multiply by $\sqrt[3]{F_{pr}/0,1 C_a}$

*** R_{nu} : Total rigidity of the complete nut. It must be multiplied by the factor f_{at} , which depends on the manufacturing tolerance. See page 48.

Nut length 1 start	Nut length 2 starts	Nut dimensions										Grease quantity TD 'steel ball'	Grease quantity TUC 'steel ball'	Ball screw reference
		$D_{1, std}$	$D_{1, min}$	D_4	D_6	M	D_5	L_7	L_1	L_8	L_9			
TDB	TUC											$Q_{gr, real, TD}$ (cm^3)	$Q_{gr, real, TUC}$ (cm^3)	
258	130	105		125	145	M12	13,5	20	25	110	127,5	31 ~ 47	16 ~ 24	TD_/TUC_-U 7050-8-2
358	180	105		125	145	M12	13,5	20	25	110	127,5	44 ~ 66	23 ~ 34	TD_/TUC_-U 7050-8-3
458	230	105		125	145	M12	13,5	20	25	110	127,5	56 ~ 84	29 ~ 44	TD_/TUC_-U 7050-8-4
127	--	110		130	150	M12	13,5	35	25	115	132,5	40 ~ 59	--	TD_-B 7012,7-9-2
153	--	110		130	150	M12	13,5	35	25	115	132,5	45 ~ 68	--	TD_-B 7012,7-9-3
178	--	110		130	150	M12	13,5	35	25	115	132,5	50 ~ 75	--	TD_-B 7012,7-9-4
204	--	110		130	150	M12	13,5	35	25	115	132,5	56 ~ 84	--	TD_-B 7012,7-9-5
242	--	110		130	150	M12	13,5	35	25	115	132,5	68 ~ 102	--	TD_-B 7012,7-9-6
267	--	110		130	150	M12	13,5	35	25	115	132,5	73 ~ 109	--	TD_-B 7012,7-9-7
292	--	110		130	150	M12	13,5	35	25	115	132,5	78 ~ 117	--	TD_-B 7012,7-9-8
318	--	110		130	150	M12	13,5	35	25	115	132,5	84 ~ 126	--	TD_-B 7012,7-9-9
343	--	110		130	150	M12	13,5	35	25	115	132,5	89 ~ 134	--	TD_-B 7012,7-9-10
371	--	110		130	150	M12	13,5	35	25	115	132,5	97 ~ 145	--	TD_-B 7012,7-9-11
396	--	110		130	150	M12	13,5	35	25	115	132,5	101 ~ 151	--	TD_-B 7012,7-9-12
422	--	110		130	150	M12	13,5	35	25	115	132,5	107 ~ 160	--	TD_-B 7012,7-9-13
447	--	110		130	150	M12	13,5	35	25	115	132,5	112 ~ 168	--	TD_-B 7012,7-9-14
472	--	110		130	150	M12	13,5	35	25	115	132,5	118 ~ 177	--	TD_-B 7012,7-9-15
499	--	110		130	150	M12	13,5	35	25	115	132,5	124 ~ 185	--	TD_-B 7012,7-9-16
147	--	110		130	150	M12	13,5	25	25	115	132,5	36 ~ 54	--	TD_-U 7016-9-2
179	--	110		130	150	M12	13,5	25	25	115	132,5	42 ~ 63	--	TD_-U 7016-9-3
211	--	110		130	150	M12	13,5	25	25	115	132,5	48 ~ 72	--	TD_-U 7016-9-4
243	--	110		130	150	M12	13,5	25	25	115	132,5	54 ~ 82	--	TD_-U 7016-9-5
275	--	110		130	150	M12	13,5	25	25	115	132,5	61 ~ 92	--	TD_-U 7016-9-6
307	--	110		130	150	M12	13,5	25	25	115	132,5	68 ~ 103	--	TD_-U 7016-9-7
339	--	110		130	150	M12	13,5	25	25	115	132,5	76 ~ 113	--	TD_-U 7016-9-8
158	--	110		130	150	M12	13,5	25	25	115	132,5	34 ~ 51	--	TD_-U 7020-9-2
198	--	110		130	150	M12	13,5	25	25	115	132,5	41 ~ 62	--	TD_-U 7020-9-3
238	--	110		130	150	M12	13,5	25	25	115	132,5	48 ~ 73	--	TD_-U 7020-9-4
278	--	110		130	150	M12	13,5	25	25	115	132,5	56 ~ 84	--	TD_-U 7020-9-5
318	--	110		130	150	M12	13,5	25	25	115	132,5	64 ~ 96	--	TD_-U 7020-9-6
358	--	110		130	150	M12	13,5	25	25	115	132,5	73 ~ 109	--	TD_-U 7020-9-7
398	--	110		130	150	M12	13,5	25	25	115	132,5	81 ~ 121	--	TD_-U 7020-9-8
174	92	110		130	150	M12	13,5	25	25	115	132,5	34 ~ 50	24 ~ 36	TD_-U/TUC_-B 7025-9-2
224	117	110		130	150	M12	13,5	25	25	115	132,5	42 ~ 64	29 ~ 44	TD_-U/TUC_-B 7025-9-3
274	142	110		130	150	M12	13,5	25	25	115	132,5	51 ~ 77	34 ~ 51	TD_-U/TUC_-B 7025-9-4
324	167	110		130	150	M12	13,5	25	25	115	132,5	60 ~ 91	40 ~ 59	TD_-U/TUC_-B 7025-9-5
374	204	110		130	150	M12	13,5	25	25	115	132,5	70 ~ 105	51 ~ 77	TD_-U/TUC_-B 7025-9-6
424	229	110		130	150	M12	13,5	25	25	115	132,5	80 ~ 120	57 ~ 85	TD_-U/TUC_-B 7025-9-7
474	254	110		130	150	M12	13,5	25	25	115	132,5	89 ~ 134	62 ~ 93	TD_-U/TUC_-B 7025-9-8
196	103	110		130	150	M12	13,5	25	25	115	132,5	36 ~ 54	20 ~ 29	TD_/TUC_-U 7030-9-2
256	133	110		130	150	M12	13,5	25	25	115	132,5	46 ~ 70	25 ~ 38	TD_/TUC_-U 7030-9-3

Key dimensions of the cylindrical nut: N, M, Y are obtained in the tables of page 38 of the catalogue.

SHUTON advises to use the dimensions of the tables, although it is possible to manufacture ball screw with other dimensions.

Smaller nut diameters than the first option of the table can reduce the rigidity of the assembly between 5 and 10%.

Please consult SHUTON.

COMPLEX, Double Nut (1start), Ultracompact Nut

Ball screw reference	Nominal diameter	Lead	Ball diameter	Root diameter	Circuits	Dynamic load capacity	Static load capacity	Rigidity of ball contact zone, with Fpr:10%Ca	Rigidity of nut, with Fpr:10%Ca
TDB Flanged double nut TDL Cylindrical double nut TDBC Centre flanged double nut TUCB Flanged Ultracompact nut TUCL Cylindrical Ultracompact nut	d_0	P_h	D_w	d_2	$i (I_e)$	$C_a (N)$	$C_{oa} (N)$	$R_{b/t,pr} (N/\mu m)$	$R_{nu} (N/\mu m)$
TD_/TUC_-U 7030-9-4	70	30	9,525	62,2	4	145900	359100	4010	3890
TD_/TUC_-U 7030-9-5	70	30	9,525	62,2	5	177600	456000	4970	4830
TD_-U 7030-9-6	70	30	9,525	62,2	6	208700	552800	5900	5730
TD_-U 7030-9-7	70	30	9,525	62,2	7	239100	649600	6790	6590
TD_-U 7030-9-8	70	30	9,525	62,2	8	269000	746500	7670	7460
TD_/TUC_-U 7040-9-2	70	40	9,525	62,2	2	81500	168300	2010	1960
TD_/TUC_-U 7040-9-3	70	40	9,525	62,2	3	113600	264500	3000	2930
TD_/TUC_-U 7040-9-4	70	40	9,525	62,2	4	145700	360700	3990	3900
TD_/TUC_-U 7040-9-5	70	40	9,525	62,2	5	177100	456900	4940	4840
TD_-U 7040-9-6	70	40	9,525	62,2	6	207900	553100	5860	5730
TD_/TUC_-U 7050-9-2	70	50	9,525	62,2	2	80600	166900	1970	1940
TD_/TUC_-U 7050-9-3	70	50	9,525	62,2	3	112300	262300	2950	2900
TD_/TUC_-U 7050-9-4	70	50	9,525	62,2	4	145100	361700	3960	3890
TD_-B 7016-12-2	70	16	12,7	61	2	117800	219900	2070	1970
TD_-B 7016-12-3	70	16	12,7	61	3	168400	359200	3250	3090
TD_-B 7016-12-4	70	16	12,7	61	4	216400	491100	4320	4100
TD_-B 7016-12-5	70	16	12,7	61	5	263400	623100	5370	5100
TD_-B 7016-12-6	70	16	12,7	61	6	311300	762300	6430	6100
TD_-B 7016-12-7	70	16	12,7	61	7	356300	894300	7380	7010
TD_-B 7016-12-8	70	16	12,7	61	8	388900	982200	8330	7920
TD_-B 7016-12-9	70	16	12,7	61	9	432600	1114200	9360	8900
TD_-B 7016-12-10	70	16	12,7	61	10	475500	1246100	10380	9870
TD_-B 7016-12-11	70	16	12,7	61	11	517900	1378100	11310	10760
TD_-B 7016-12-12	70	16	12,7	61	12	563300	1524700	12440	11830
TD_-B 7016-12-13	70	16	12,7	61	13	604500	1656600	13360	12710
TD_-B 7020-15-2	70	20	15,875	57	2	157100	272700	1970	1890
TD_-B 7020-15-3	70	20	15,875	57	3	222300	438700	2960	2840
TD_-B 7020-15-4	70	20	15,875	57	4	290900	616500	4070	3910
TD_-B 7020-15-5	70	20	15,875	57	5	354200	782500	5040	4840
TD_-B 7020-15-6	70	20	15,875	57	6	419600	960300	6080	5840
TD_-B 7020-15-7	70	20	15,875	57	7	480100	1126300	6980	6710
TD_-B 7020-15-8	70	20	15,875	57	8	542900	1304100	7950	7650
TD_-B 7020-15-9	70	20	15,875	57	9	581700	1399000	8800	8470
TD_-U 8012-8-2	80	12	7,938	73,3	2	69300	163800	2260	2090
TD_-U 8012-8-3	80	12	7,938	73,3	3	95700	254200	3340	3090
TD_-U 8012-8-4	80	12	7,938	73,3	4	122900	347500	4450	4120
TD_-U 8012-8-5	80	12	7,938	73,3	5	148900	437900	5500	5090
TD_-U 8012-8-6	80	12	7,938	73,3	6	174400	528300	6510	6030
TD_-U 8015-8-2	80	15	7,938	73,3	2	69200	163700	2260	2120
TD_-U 8015-8-3	80	15	7,938	73,3	3	95600	254100	3340	3140
TD_-U 8015-8-4	80	15	7,938	73,3	4	122800	347300	4450	4180

* C_a and C_{oa} : Modified static and dynamic load capacities, calculated according to DIN 69051/4 standard and ISO3408/5. See pages 39 and 43.

** $R_{b/t,pr}$: Rigidity of the balls contact zone for an external force 10% of C_a . See page 47. For a different preload force, multiply by $\sqrt[3]{F_{pr}/0,1 C_a}$

*** R_{nu} : Total rigidity of the complete nut. It must be multiplied by the factor $f_{a'}$, which depends on the manufacturing tolerance. See page 48.

Nut length 1 start	Nut length 2 starts	Nut dimensions										Grease quantity TD 'steel ball'	Grease quantity TUC 'steel ball'	Ball screw reference
		$D_{1, std}$	$D_{1, min}$	D_4	D_6	M	D_5	L_7	L_1	L_8	L_9			
<i>TDB</i>	<i>TUC</i>											$Q_{gr, real, TD}$ (cm^3)	$Q_{gr, real, TUC}$ (cm^3)	
316	163	110		130	150	M12	13,5	25	25	115	132,5	57 ~ 85	31 ~ 47	TD_/TUC_-U 7030-9-4
376	193	110		130	150	M12	13,5	25	25	115	132,5	67 ~ 101	37 ~ 56	TD_/TUC_-U 7030-9-5
436	--	110		130	150	M12	13,5	25	25	115	132,5	78 ~ 118	--	TD_-U 7030-9-6
496	--	110		130	150	M12	13,5	25	25	115	132,5	90 ~ 135	--	TD_-U 7030-9-7
539	--	110		130	150	M12	13,5	25	25	115	132,5	96 ~ 144	--	TD_-U 7030-9-8
224	114	110		130	150	M12	13,5	25	25	115	132,5	37 ~ 56	18 ~ 27	TD_/TUC_-U 7040-9-2
304	154	110		130	150	M12	13,5	25	25	115	132,5	51 ~ 76	26 ~ 38	TD_/TUC_-U 7040-9-3
384	194	110		130	150	M12	13,5	25	25	115	132,5	64 ~ 96	33 ~ 50	TD_/TUC_-U 7040-9-4
464	234	110		130	150	M12	13,5	25	25	115	132,5	78 ~ 117	41 ~ 61	TD_/TUC_-U 7040-9-5
534	--	110		130	150	M12	13,5	25	25	115	132,5	89 ~ 134	--	TD_-U 7040-9-6
258	128	110		130	150	M12	13,5	25	25	115	132,5	41 ~ 62	19 ~ 29	TD_/TUC_-U 7050-9-2
358	178	110		130	150	M12	13,5	25	25	115	132,5	58 ~ 87	28 ~ 42	TD_/TUC_-U 7050-9-3
458	228	110		130	150	M12	13,5	25	25	115	132,5	74 ~ 111	37 ~ 55	TD_/TUC_-U 7050-9-4
144	--	120		140	160	M12	13,5	40	25	125	142,5	62 ~ 92	--	TD_-B 7016-12-2
176	--	120		140	160	M12	13,5	40	25	125	142,5	69 ~ 104	--	TD_-B 7016-12-3
208	--	120		140	160	M12	13,5	40	25	125	142,5	78 ~ 117	--	TD_-B 7016-12-4
240	--	120		140	160	M12	13,5	40	25	125	142,5	87 ~ 131	--	TD_-B 7016-12-5
272	--	120		140	160	M12	13,5	40	25	125	142,5	96 ~ 144	--	TD_-B 7016-12-6
304	--	120		140	160	M12	13,5	40	25	125	142,5	106 ~ 160	--	TD_-B 7016-12-7
352	--	120		140	160	M12	13,5	40	25	125	142,5	126 ~ 188	--	TD_-B 7016-12-8
384	--	120		140	160	M12	13,5	40	25	125	142,5	135 ~ 202	--	TD_-B 7016-12-9
416	--	120		140	160	M12	13,5	40	25	125	142,5	143 ~ 215	--	TD_-B 7016-12-10
448	--	120		140	160	M12	13,5	40	25	125	142,5	154 ~ 231	--	TD_-B 7016-12-11
480	--	120		140	160	M12	13,5	40	25	125	142,5	161 ~ 242	--	TD_-B 7016-12-12
512	--	120		140	160	M12	13,5	40	25	125	142,5	172 ~ 258	--	TD_-B 7016-12-13
175	--	130		150	170	M12	13,5	45	25	135	152,5	99 ~ 148	--	TD_-B 7020-15-2
215	--	130		150	170	M12	13,5	45	25	135	152,5	115 ~ 172	--	TD_-B 7020-15-3
255	--	130		150	170	M12	13,5	45	25	135	152,5	128 ~ 192	--	TD_-B 7020-15-4
295	--	130		150	170	M12	13,5	45	25	135	152,5	144 ~ 215	--	TD_-B 7020-15-5
335	--	130		150	170	M12	13,5	45	25	135	152,5	158 ~ 237	--	TD_-B 7020-15-6
375	--	130		150	170	M12	13,5	45	25	135	152,5	175 ~ 263	--	TD_-B 7020-15-7
415	--	130		150	170	M12	13,5	45	25	135	152,5	191 ~ 286	--	TD_-B 7020-15-8
455	--	130		150	170	M12	13,5	45	25	135	152,5	207 ~ 310	--	TD_-B 7020-15-9
130	--	125	(115)	145 (135)	165 (155)	M12	13,5	25	25	130 (120)	147,5 (137,5)	33 ~ 49	--	TD_-U 8012-8-2
154	--	125	(115)	145 (135)	165 (155)	M12	13,5	25	25	130 (120)	147,5 (137,5)	37 ~ 56	--	TD_-U 8012-8-3
178	--	125	(115)	145 (135)	165 (155)	M12	13,5	25	25	130 (120)	147,5 (137,5)	41 ~ 62	--	TD_-U 8012-8-4
202	--	125	(115)	145 (135)	165 (155)	M12	13,5	25	25	130 (120)	147,5 (137,5)	46 ~ 69	--	TD_-U 8012-8-5
226	--	125	(115)	145 (135)	165 (155)	M12	13,5	25	25	130 (120)	147,5 (137,5)	51 ~ 76	--	TD_-U 8012-8-6
133	--	125	(115)	145 (135)	165 (155)	M12	13,5	25	25	130 (120)	147,5 (137,5)	28 ~ 42	--	TD_-U 8015-8-2
165	--	125	(115)	145 (135)	165 (155)	M12	13,5	25	25	130 (120)	147,5 (137,5)	33 ~ 50	--	TD_-U 8015-8-3
195	--	125	(115)	145 (135)	165 (155)	M12	13,5	25	25	130 (120)	147,5 (137,5)	38 ~ 57	--	TD_-U 8015-8-4

Key dimensions of the cylindrical nut: N, M, Y are obtained in the tables of page 38 of the catalogue.

SHUTON advises to use the dimensions of the tables, although it is possible to manufacture ball screw with other dimensions.

Smaller nut diameters than the first option of the table can reduce the rigidity of the assembly between 5 and 10%.

Please consult SHUTON.

COMPLEX, Double Nut (1start), Ultracompact Nut

Ball screw reference	Nominal diameter	Lead	Ball diameter	Root diameter	Circuits	Dynamic load capacity	Static load capacity	Rigidity of ball contact zone, with Fpr:10%Ca	Rigidity of nut, with Fpr:10%Ca
TDB Flanged double nut TDL Cylindrical double nut TDBC Centre flanged double nut TUCB Flanged Ultracompact nut TUCL Cylindrical Ultracompact nut	d_0	P_h	D_w	d_2	$i (I_e)$	$C_a (N)$	$C_{oa} (N)$	$R_{b/t,pr} (N/\mu m)$	$R_{nu} (N/\mu m)$
TD_-U 8015-8-5	80	15	7,938	73,3	5	148800	437600	5490	5160
TD_-U 8015-8-6	80	15	7,938	73,3	6	174300	527900	6500	6110
TD_-U 8016-8-2	80	16	7,938	73,3	2	69200	163700	2260	2130
TD_-U 8016-8-3	80	16	7,938	73,3	3	95600	254000	3340	3150
TD_-U 8016-8-4	80	16	7,938	73,3	4	122800	347200	4450	4190
TD_-U 8016-8-5	80	16	7,938	73,3	5	148800	437500	5490	5180
TD_-U 8016-8-6	80	16	7,938	73,3	6	174200	527800	6490	6130
TD_-B 8012,7-9-2	80	12,7	9,525	72,2	2	88700	196300	2290	2100
TD_-B 8012,7-9-3	80	12,7	9,525	72,2	3	123000	306700	3420	3140
TD_-B 8012,7-9-4	80	12,7	9,525	72,2	4	157500	417100	4560	4180
TD_-B 8012,7-9-5	80	12,7	9,525	72,2	5	184400	498900	5420	5000
TD_-B 8012,7-9-6	80	12,7	9,525	72,2	6	218600	613400	6580	6060
TD_-B 8012,7-9-7	80	12,7	9,525	72,2	7	250300	719700	7650	7050
TD_-B 8012,7-9-8	80	12,7	9,525	72,2	8	283200	834300	8790	8100
TD_-B 8012,7-9-9	80	12,7	9,525	72,2	9	309100	920100	9680	8930
TD_-B 8012,7-9-10	80	12,7	9,525	72,2	10	340100	1030500	10740	9910
TD_-B 8012,7-9-11	80	12,7	9,525	72,2	11	370700	1141000	11890	10960
TD_-B 8012,7-9-12	80	12,7	9,525	72,2	12	400800	1251400	12940	11940
TD_-B 8012,7-9-13	80	12,7	9,525	72,2	13	426300	1341300	13910	12840
TD_-B 8012,7-9-14	80	12,7	9,525	72,2	14	453300	1439500	14800	13680
TD_-B 8012,7-9-15	80	12,7	9,525	72,2	15	483400	1554000	15850	14650
TD_-B 8012,7-9-16	80	12,7	9,525	72,2	16	513200	1668500	17020	15720
TD_-U 8016-9-2	80	16	9,525	72,2	2	88600	196200	2280	2140
TD_-U 8016-9-3	80	16	9,525	72,2	3	122900	306500	3420	3210
TD_-U 8016-9-4	80	16	9,525	72,2	4	157400	416800	4550	4270
TD_-U 8016-9-5	80	16	9,525	72,2	5	191200	527200	5610	5270
TD_-U 8016-9-6	80	16	9,525	72,2	6	224200	637500	6660	6270
TD_-U 8016-9-7	80	16	9,525	72,2	7	256600	747800	7670	7220
TD_-U 8020-9-2	80	20	9,525	72,2	2	88500	195900	2280	2170
TD_-U 8020-9-3	80	20	9,525	72,2	3	122700	306200	3410	3240
TD_-U 8020-9-4	80	20	9,525	72,2	4	157200	416400	4540	4320
TD_-U 8020-9-5	80	20	9,525	72,2	5	190900	526600	5600	5320
TD_-U 8020-9-6	80	20	9,525	72,2	6	223900	636800	6640	6330
TD_-U 8020-9-7	80	20	9,525	72,2	7	256300	747000	7660	7290
TD_-U/TUC_-B 8025-9-2	80	25	9,525	72,2	2	88300	195600	2270	2180
TD_-U/TUC_-B 8025-9-3	80	25	9,525	72,2	3	122500	305600	3400	3260
TD_-U/TUC_-B 8025-9-4	80	25	9,525	72,2	4	156800	415700	4520	4340
TD_-U/TUC_-B 8025-9-5	80	25	9,525	72,2	5	190500	525700	5580	5360
TD_-U/TUC_-B 8025-9-6	80	25	9,525	72,2	6	224400	639800	6660	6400
TD_-U/TUC_-B 8025-9-7	80	25	9,525	72,2	7	256600	749900	7670	7380
TD_/TUC_-U 8030-9-2	80	30	9,525	72,2	2	88000	195200	2260	2180

* C_a and C_{oa} : Modified static and dynamic load capacities, calculated according to DIN 69051/4 standard and ISO3408/5. See pages 39 and 43.

** $R_{b/t,pr}$: Rigidity of the balls contact zone for an external force 10% of C_a . See page 47. For a different preload force, multiply by $\sqrt[3]{F_{pr}/0,1 C_a}$

*** R_{nu} : Total rigidity of the complete nut. It must be multiplied by the factor $f_{a'}$, which depends on the manufacturing tolerance. See page 48.

Nut length 1 start	Nut length 2 starts	Nut dimensions										Grease quantity TD 'steel ball'	Grease quantity TUC 'steel ball'	Ball screw reference
		$D_{1, std}$	$D_{1, min}$	D_4	D_6	M	D_5	L_7	L_1	L_8	L_9			
TDB	TUC											$Q_{gr, real, TD}$ (cm^3)	$Q_{gr, real, TUC}$ (cm^3)	
223	--	125	(115)	145 (135)	165 (155)	M12	13,5	25	25	130 (120)	147,5 (137,5)	44 ~ 65	--	TD_U 8015-8-5
255	--	125	(115)	145 (135)	165 (155)	M12	13,5	25	25	130 (120)	147,5 (137,5)	49 ~ 74	--	TD_U 8015-8-6
141	--	125	(115)	145 (135)	165 (155)	M12	13,5	25	25	130 (120)	147,5 (137,5)	29 ~ 44	--	TD_U 8016-8-2
173	--	125	(115)	145 (135)	165 (155)	M12	13,5	25	25	130 (120)	147,5 (137,5)	35 ~ 52	--	TD_U 8016-8-3
205	--	125	(115)	145 (135)	165 (155)	M12	13,5	25	25	130 (120)	147,5 (137,5)	40 ~ 60	--	TD_U 8016-8-4
237	--	125	(115)	145 (135)	165 (155)	M12	13,5	25	25	130 (120)	147,5 (137,5)	46 ~ 68	--	TD_U 8016-8-5
269	--	125	(115)	145 (135)	165 (155)	M12	13,5	25	25	130 (120)	147,5 (137,5)	51 ~ 77	--	TD_U 8016-8-6
127	--	120		140	160	M12	13,5	35	25	125	142,5	45 ~ 67	--	TD_B 8012,7-9-2
153	--	120		140	160	M12	13,5	35	25	125	142,5	51 ~ 77	--	TD_B 8012,7-9-3
178	--	120		140	160	M12	13,5	35	25	125	142,5	57 ~ 85	--	TD_B 8012,7-9-4
216	--	120		140	160	M12	13,5	35	25	125	142,5	71 ~ 107	--	TD_B 8012,7-9-5
242	--	120		140	160	M12	13,5	35	25	125	142,5	77 ~ 115	--	TD_B 8012,7-9-6
267	--	120		140	160	M12	13,5	35	25	125	142,5	83 ~ 124	--	TD_B 8012,7-9-7
292	--	120		140	160	M12	13,5	35	25	125	142,5	88 ~ 132	--	TD_B 8012,7-9-8
320	--	120		140	160	M12	13,5	35	25	125	142,5	97 ~ 145	--	TD_B 8012,7-9-9
345	--	120		140	160	M12	13,5	35	25	125	142,5	103 ~ 154	--	TD_B 8012,7-9-10
371	--	120		140	160	M12	13,5	35	25	125	142,5	108 ~ 163	--	TD_B 8012,7-9-11
396	--	120		140	160	M12	13,5	35	25	125	142,5	114 ~ 172	--	TD_B 8012,7-9-12
423	--	120		140	160	M12	13,5	35	25	125	142,5	122 ~ 183	--	TD_B 8012,7-9-13
448	--	120		140	160	M12	13,5	35	25	125	142,5	129 ~ 193	--	TD_B 8012,7-9-14
473	--	120		140	160	M12	13,5	35	25	125	142,5	135 ~ 202	--	TD_B 8012,7-9-15
499	--	120		140	160	M12	13,5	35	25	125	142,5	140 ~ 210	--	TD_B 8012,7-9-16
147	--	125	(120)	145 (140)	165 (160)	M12	13,5	25	25	130 (125)	147,5 (142,5)	40 ~ 61	--	TD_U 8016-9-2
179	--	125	(120)	145 (140)	165 (160)	M12	13,5	25	25	130 (125)	147,5 (142,5)	47 ~ 71	--	TD_U 8016-9-3
211	--	125	(120)	145 (140)	165 (160)	M12	13,5	25	25	130 (125)	147,5 (142,5)	54 ~ 82	--	TD_U 8016-9-4
243	--	125	(120)	145 (140)	165 (160)	M12	13,5	25	25	130 (125)	147,5 (142,5)	62 ~ 93	--	TD_U 8016-9-5
275	--	125	(120)	145 (140)	165 (160)	M12	13,5	25	25	130 (125)	147,5 (142,5)	70 ~ 104	--	TD_U 8016-9-6
307	--	125	(120)	145 (140)	165 (160)	M12	13,5	25	25	130 (125)	147,5 (142,5)	78 ~ 116	--	TD_U 8016-9-7
158	--	125	(120)	145 (140)	165 (160)	M12	13,5	25	25	130 (125)	147,5 (142,5)	38 ~ 57	--	TD_U 8020-9-2
198	--	125	(120)	145 (140)	165 (160)	M12	13,5	25	25	130 (125)	147,5 (142,5)	47 ~ 70	--	TD_U 8020-9-3
238	--	125	(120)	145 (140)	165 (160)	M12	13,5	25	25	130 (125)	147,5 (142,5)	55 ~ 82	--	TD_U 8020-9-4
278	--	125	(120)	145 (140)	165 (160)	M12	13,5	25	25	130 (125)	147,5 (142,5)	64 ~ 96	--	TD_U 8020-9-5
318	--	125	(120)	145 (140)	165 (160)	M12	13,5	25	25	130 (125)	147,5 (142,5)	73 ~ 109	--	TD_U 8020-9-6
358	--	125	(120)	145 (140)	165 (160)	M12	13,5	25	25	130 (125)	147,5 (142,5)	82 ~ 123	--	TD_U 8020-9-7
176	92	125	(120)	145 (140)	165 (160)	M12	13,5	25	25	130 (125)	147,5 (142,5)	39 ~ 58	27 ~ 41	TD_U/TUC_B 8025-9-2
226	117	125	(120)	145 (140)	165 (160)	M12	13,5	25	25	130 (125)	147,5 (142,5)	49 ~ 73	33 ~ 49	TD_U/TUC_B 8025-9-3
276	142	125	(120)	145 (140)	165 (160)	M12	13,5	25	25	130 (125)	147,5 (142,5)	59 ~ 88	39 ~ 58	TD_U/TUC_B 8025-9-4
326	179	125	(120)	145 (140)	165 (160)	M12	13,5	25	25	130 (125)	147,5 (142,5)	70 ~ 104	53 ~ 79	TD_U/TUC_B 8025-9-5
376	204	125	(120)	145 (140)	165 (160)	M12	13,5	25	25	130 (125)	147,5 (142,5)	80 ~ 120	58 ~ 87	TD_U/TUC_B 8025-9-6
426	229	125	(120)	145 (140)	165 (160)	M12	13,5	25	25	130 (125)	147,5 (142,5)	91 ~ 137	64 ~ 96	TD_U/TUC_B 8025-9-7
198	103	125	(120)	145 (140)	165 (160)	M12	13,5	25	25	130 (125)	147,5 (142,5)	41 ~ 62	22 ~ 33	TD_U/TUC_U 8030-9-2

Key dimensions of the cylindrical nut: N, M, Y are obtained in the tables of page 38 of the catalogue.

SHUTON advises to use the dimensions of the tables, although it is possible to manufacture ball screw with other dimensions.

Smaller nut diameters than the first option of the table can reduce the rigidity of the assembly between 5 and 10%.

Please consult SHUTON.

COMPLEX, Double Nut (1start), Ultracompact Nut

Ball screw reference	Nominal diameter	Lead	Ball diameter	Root diameter	Circuits	Dynamic load capacity	Static load capacity	Rigidity of ball contact zone, with Fpr:10%Ca	Rigidity of nut, with Fpr:10%Ca
TDB Flanged double nut TDL Cylindrical double nut TDBC Centre flanged double nut TUCB Flanged Ultracompact nut TUCL Cylindrical Ultracompact nut	d_0	P_h	D_w	d_2	$i (I_e)$	$C_a(N)$	$C_{oa} (N)$	$R_{b/t,pr} (N/\mu m)$	$R_{nu} (N/\mu m)$
TD_/TUC_-U 8030-9-3	80	30	9,525	72,2	3	122200	305000	3380	3270
TD_/TUC_-U 8030-9-4	80	30	9,525	72,2	4	156400	414800	4500	4350
TD_/TUC_-U 8030-9-5	80	30	9,525	72,2	5	191000	528700	5590	5410
TD_-U 8030-9-6	80	30	9,525	72,2	6	223800	638500	6630	6420
TD_-U 8030-9-7	80	30	9,525	72,2	7	255900	748300	7640	7390
TD_/TUC_-U 8040-9-2	80	40	9,525	72,2	2	87400	194200	2230	2180
TD_/TUC_-U 8040-9-3	80	40	9,525	72,2	3	122400	307500	3390	3300
TD_/TUC_-U 8040-9-4	80	40	9,525	72,2	4	156400	416700	4500	4380
TD_/TUC_-U 8040-9-5	80	40	9,525	72,2	5	189700	526000	5530	5400
TD_-U 8040-9-6	80	40	9,525	72,2	6	223200	639300	6600	6440
TD_/TUC_-U 8050-9-2	80	50	9,525	72,2	2	87900	197000	2250	2200
TD_/TUC_-U 8050-9-3	80	50	9,525	72,2	3	121400	305500	3340	3280
TD_/TUC_-U 8050-9-4	80	50	9,525	72,2	4	156000	418000	4470	4380
TD_/TUC_-U 8050-9-5	80	50	9,525	72,2	5	189000	526500	5500	5390
TD_-U 8020-11-2	80	20	11,113	71,1	2	107600	225700	2280	2160
TD_-U 8020-11-3	80	20	11,113	71,1	3	151700	361200	3460	3290
TD_-U 8020-11-4	80	20	11,113	71,1	4	194100	491000	4590	4360
TD_-U 8020-11-5	80	20	11,113	71,1	5	235800	620800	5680	5390
TD_-U 8020-11-6	80	20	11,113	71,1	6	277900	756200	6760	6420
TD_-U 8020-11-7	80	20	11,113	71,1	7	317800	886000	7790	7410
TD_-U 8020-11-8	80	20	11,113	71,1	8	358200	1021400	8790	8360
TD_-U 8025-11-2	80	25	11,113	71,1	2	107300	225400	2270	2180
TD_-U 8025-11-3	80	25	11,113	71,1	3	151300	360600	3450	3310
TD_-U 8025-11-4	80	25	11,113	71,1	4	193700	490100	4580	4390
TD_-U 8025-11-5	80	25	11,113	71,1	5	236700	625400	5700	5470
TD_-U 8025-11-6	80	25	11,113	71,1	6	277300	754900	6740	6470
TD_-U 8025-11-7	80	25	11,113	71,1	7	318400	890100	7810	7500
TD_-U 8025-11-8	80	25	11,113	71,1	8	357500	1019700	8760	8420
TD_-U 8030-11-2	80	30	11,113	71,1	2	107100	224900	2260	2180
TD_-U 8030-11-3	80	30	11,113	71,1	3	150900	359800	3440	3320
TD_-U 8030-11-4	80	30	11,113	71,1	4	193200	489200	4560	4400
TD_-U 8030-11-5	80	30	11,113	71,1	5	236100	624100	5680	5490
TD_-U 8030-11-6	80	30	11,113	71,1	6	276600	753400	6710	6490
TD_-U 8030-11-7	80	30	11,113	71,1	7	317600	888300	7780	7520
TD_-U 8030-11-8	80	30	11,113	71,1	8	356500	1017700	8720	8440
TD_-U 8040-11-2	80	40	11,113	71,1	2	108100	229300	2290	2230
TD_-U 8040-11-3	80	40	11,113	71,1	3	149900	358000	3400	3310
TD_-U 8040-11-4	80	40	11,113	71,1	4	193400	492300	4560	4440
TD_-U 8040-11-5	80	40	11,113	71,1	5	235900	626500	5670	5520
TD_-U 8040-11-6	80	40	11,113	71,1	6	276100	755200	6690	6520
TD_-U 8050-11-2	80	50	11,113	71,1	2	107200	227900	2260	2210

* C_a and C_{oa} : Modified static and dynamic load capacities, calculated according to DIN 69051/4 standard and ISO3408/5. See pages 39 and 43.

** $R_{b/t,pr}$: Rigidity of the balls contact zone for an external force 10% of C_a . See page 47. For a different preload force, multiply by $\sqrt[3]{F_{pr}/0,1 C_a}$

*** R_{nu} : Total rigidity of the complete nut. It must be multiplied by the factor $f_{a'}$, which depends on the manufacturing tolerance. See page 48.

Nut length 1 start	Nut length 2 starts	Nut dimensions										Grease quantity TD 'steel ball'	Grease quantity TUC 'steel ball'	Ball screw reference
		$D_{1, std}$	$D_{1, min}$	D_4	D_6	M	D_5	L_7	L_1	L_8	L_9			
<i>TDB</i>	<i>TUC</i>											$Q_{gr, real, TD}$ (cm^3)	$Q_{gr, real, TUC}$ (cm^3)	
258	133	125	(120)	145 (140)	165 (160)	M12	13,5	25	25	130 (125)	147,5 (142,5)	53 ~ 80	29 ~ 43	TD_/TUC_-U 8030-9-3
318	163	125	(120)	145 (140)	165 (160)	M12	13,5	25	25	130 (125)	147,5 (142,5)	65 ~ 98	35 ~ 53	TD_/TUC_-U 8030-9-4
378	193	125	(120)	145 (140)	165 (160)	M12	13,5	25	25	130 (125)	147,5 (142,5)	77 ~ 116	42 ~ 64	TD_/TUC_-U 8030-9-5
438	--	125	(120)	145 (140)	165 (160)	M12	13,5	25	25	130 (125)	147,5 (142,5)	90 ~ 134	--	TD_-U 8030-9-6
498	--	125	(120)	145 (140)	165 (160)	M12	13,5	25	25	130 (125)	147,5 (142,5)	102 ~ 154	--	TD_-U 8030-9-7
228	113	125	(120)	145 (140)	165 (160)	M12	13,5	25	25	130 (125)	147,5 (142,5)	44 ~ 65	20 ~ 31	TD_/TUC_-U 8040-9-2
308	163	125	(120)	145 (140)	165 (160)	M12	13,5	25	25	130 (125)	147,5 (142,5)	59 ~ 88	29 ~ 43	TD_/TUC_-U 8040-9-3
388	193	125	(120)	145 (140)	165 (160)	M12	13,5	25	25	130 (125)	147,5 (142,5)	74 ~ 111	37 ~ 56	TD_/TUC_-U 8040-9-4
468	233	125	(120)	145 (140)	165 (160)	M12	13,5	25	25	130 (125)	147,5 (142,5)	90 ~ 135	46 ~ 69	TD_/TUC_-U 8040-9-5
548	--	125	(120)	145 (140)	165 (160)	M12	13,5	25	25	130 (125)	147,5 (142,5)	106 ~ 158	--	TD_-U 8040-9-6
262	130	125	(120)	145 (140)	165 (160)	M12	13,5	25	25	130 (125)	147,5 (142,5)	48 ~ 72	22 ~ 34	TD_/TUC_-U 8050-9-2
362	180	125	(120)	145 (140)	165 (160)	M12	13,5	25	25	130 (125)	147,5 (142,5)	67 ~ 100	33 ~ 49	TD_/TUC_-U 8050-9-3
462	230	125	(120)	145 (140)	165 (160)	M12	13,5	25	25	130 (125)	147,5 (142,5)	85 ~ 128	43 ~ 64	TD_/TUC_-U 8050-9-4
562	280	125	(120)	145 (140)	165 (160)	M12	13,5	25	25	130 (125)	147,5 (142,5)	105 ~ 157	53 ~ 80	TD_/TUC_-U 8050-9-5
169	--	125		145	165	M12	13,5	25	25	130	147,5	57 ~ 85	--	TD_-U 8020-11-2
209	--	125		145	165	M12	13,5	25	25	130	147,5	67 ~ 100	--	TD_-U 8020-11-3
249	--	125		145	165	M12	13,5	25	25	130	147,5	78 ~ 116	--	TD_-U 8020-11-4
289	--	125		145	165	M12	13,5	25	25	130	147,5	89 ~ 133	--	TD_-U 8020-11-5
329	--	125		145	165	M12	13,5	25	25	130	147,5	100 ~ 150	--	TD_-U 8020-11-6
369	--	125		145	165	M12	13,5	25	25	130	147,5	111 ~ 167	--	TD_-U 8020-11-7
409	--	125		145	165	M12	13,5	25	25	130	147,5	123 ~ 185	--	TD_-U 8020-11-8
198	--	125		145	165	M12	13,5	25	25	130	147,5	61 ~ 92	--	TD_-U 8025-11-2
248	--	125		145	165	M12	13,5	25	25	130	147,5	74 ~ 110	--	TD_-U 8025-11-3
298	--	125		145	165	M12	13,5	25	25	130	147,5	86 ~ 130	--	TD_-U 8025-11-4
348	--	125		145	165	M12	13,5	25	25	130	147,5	99 ~ 149	--	TD_-U 8025-11-5
398	--	125		145	165	M12	13,5	25	25	130	147,5	113 ~ 170	--	TD_-U 8025-11-6
448	--	125		145	165	M12	13,5	25	25	130	147,5	126 ~ 189	--	TD_-U 8025-11-7
498	--	125		145	165	M12	13,5	25	25	130	147,5	141 ~ 211	--	TD_-U 8025-11-8
194	--	125		145	165	M12	13,5	25	25	130	147,5	53 ~ 79	--	TD_-U 8030-11-2
254	--	125		145	165	M12	13,5	25	25	130	147,5	67 ~ 101	--	TD_-U 8030-11-3
314	--	125		145	165	M12	13,5	25	25	130	147,5	82 ~ 123	--	TD_-U 8030-11-4
374	--	125		145	165	M12	13,5	25	25	130	147,5	97 ~ 146	--	TD_-U 8030-11-5
434	--	125		145	165	M12	13,5	25	25	130	147,5	113 ~ 170	--	TD_-U 8030-11-6
494	--	125		145	165	M12	13,5	25	25	130	147,5	129 ~ 193	--	TD_-U 8030-11-7
554	--	125		145	165	M12	13,5	25	25	130	147,5	146 ~ 218	--	TD_-U 8030-11-8
243	--	125		145	165	M12	13,5	25	25	130	147,5	62 ~ 93	--	TD_-U 8040-11-2
323	--	125		145	165	M12	13,5	25	25	130	147,5	81 ~ 122	--	TD_-U 8040-11-3
403	--	125		145	165	M12	13,5	25	25	130	147,5	100 ~ 150	--	TD_-U 8040-11-4
483	--	125		145	165	M12	13,5	25	25	130	147,5	119 ~ 179	--	TD_-U 8040-11-5
563	--	125		145	165	M12	13,5	25	25	130	147,5	140 ~ 210	--	TD_-U 8040-11-6
262	--	125		145	165	M12	13,5	25	25	130	147,5	62 ~ 93	--	TD_-U 8050-11-2

Key dimensions of the cylindrical nut: N, M, Y are obtained in the tables of page 38 of the catalogue.

SHUTON advises to use the dimensions of the tables, although it is possible to manufacture ball screw with other dimensions.

Smaller nut diameters than the first option of the table can reduce the rigidity of the assembly between 5 and 10%.

Please consult SHUTON.

COMPLEX, Double Nut (1start), Ultracompact Nut

Ball screw reference	Nominal diameter	Lead	Ball diameter	Root diameter	Circuits	Dynamic load capacity	Static load capacity	Rigidity of ball contact zone, with Fpr:10%Ca	Rigidity of nut, with Fpr:10%Ca
TDB Flanged double nut TDL Cylindrical double nut TDBC Centre flanged double nut TUCB Flanged Ultracompact nut TUCL Cylindrical Ultracompact nut	d_0	P_h	D_w	d_2	$i (Ie)$	$C_a(N)$	$C_{oa} (N)$	$R_{b/t,pr} (N/\mu m)$	$R_{nu} (N/\mu m)$
TD_-U 8050-11-3	80	50	11,113	71,1	3	150200	361200	3400	3330
TD_-U 8050-11-4	80	50	11,113	71,1	4	193200	494600	4540	4450
TD_-U 8050-11-5	80	50	11,113	71,1	5	233900	622400	5590	5480
TD_-B 8016-12-2	80	16	12,7	71	2	128300	258600	2380	2240
TD_-B 8016-12-3	80	16	12,7	71	3	180900	413800	3620	3400
TD_-B 8016-12-4	80	16	12,7	71	4	233400	568900	4850	4560
TD_-B 8016-12-5	80	16	12,7	71	5	284700	724100	6070	5700
TD_-B 8016-12-6	80	16	12,7	71	6	332900	871900	7180	6750
TD_-B 8016-12-7	80	16	12,7	71	7	369200	975300	8110	7640
TD_-B 8016-12-8	80	16	12,7	71	8	419500	1137900	9360	8810
TD_-B 8016-12-9	80	16	12,7	71	9	465300	1285600	10490	9880
TD_-B 8016-12-10	80	16	12,7	71	10	514000	1448200	11730	11040
TD_-B 8016-12-11	80	16	12,7	71	11	558400	1596000	12760	12020
TD_-B 8016-12-12	80	16	12,7	71	12	602300	1743800	13880	13070
TD_-B 8016-12-13	80	16	12,7	71	13	639000	1862000	15020	14150
TD_-B 8016-12-14	80	16	12,7	71	14	683700	2017100	16140	15210
TD_-B 8016-12-15	80	16	12,7	71	15	727900	2172300	17260	16260
TD_-B 8016-12-16	80	16	12,7	71	16	771700	2327500	18370	17320
TD_-B 8016-12-17	80	16	12,7	71	17	810300	2460500	19320	18220
TD_-B 8016-12-18	80	16	12,7	71	18	853300	2615600	20430	19260
TD_-U 8020-12-2	80	20	12,7	71	2	128200	258300	2380	2270
TD_-U 8020-12-3	80	20	12,7	71	3	180700	413300	3610	3450
TD_-U 8020-12-4	80	20	12,7	71	4	233100	568400	4840	4620
TD_-U 8020-12-5	80	20	12,7	71	5	284300	723400	6060	5780
TD_-U 8020-12-6	80	20	12,7	71	6	334400	878400	7220	6890
TD_-U 8020-12-7	80	20	12,7	71	7	381600	1026000	8270	7900
TD_-U 8020-12-8	80	20	12,7	71	8	429700	1181000	9330	8920
TD_-U 8025-12-2	80	25	12,7	71	2	127900	257900	2370	2280
TD_-U 8025-12-3	80	25	12,7	71	3	180300	412700	3600	3470
TD_-U 8025-12-4	80	25	12,7	71	4	232600	567400	4820	4640
TD_-U 8025-12-5	80	25	12,7	71	5	283700	722200	6040	5810
TD_-U 8025-12-6	80	25	12,7	71	6	333700	877000	7190	6930
TD_-U 8025-12-7	80	25	12,7	71	7	382600	1031700	8300	8000
TD_-U 8025-12-8	80	25	12,7	71	8	430600	1186500	9360	9020
TD_-U 8030-12-2	80	30	12,7	71	2	127600	257400	2360	2290
TD_-U 8030-12-3	80	30	12,7	71	3	179900	411900	3590	3470
TD_-U 8030-12-4	80	30	12,7	71	4	232000	566300	4800	4650
TD_-U 8030-12-5	80	30	12,7	71	5	283000	720800	6010	5820
TD_-U 8030-12-6	80	30	12,7	71	6	332800	875200	7160	6940
TD_-U 8030-12-7	80	30	12,7	71	7	381600	1029700	8270	8010
TD_-U 8030-12-8	80	30	12,7	71	8	429500	1184200	9320	9040

* Ca and Coa: Modified static and dynamic load capacities, calculated according to DIN 69051/4 standard and ISO3408/5. See pages 39 and 43.

** Rb/t,pr: Rigidity of the balls contact zone for an external force 10% of Ca. See page 47. For a different preload force, multiply by $\sqrt[3]{F_{pr}/0,1 C_a}$

*** Rnu: Total rigidity of the complete nut. It must be multiplied by the factor f_{ar} , which depends on the manufacturing tolerance. See page 48.

Nut length 1 start	Nut length 2 starts	Nut dimensions										Grease quantity TD 'steel ball'	Grease quantity TUC 'steel ball'	Ball screw reference
		<i>D</i> _{1, std}	<i>D</i> _{1, min}	<i>D</i> ₄	<i>D</i> ₆	<i>M</i>	<i>D</i> ₅	<i>L</i> ₇	<i>L</i> ₁	<i>L</i> ₈	<i>L</i> ₉			
<i>TDB</i>	<i>TUC</i>	<i>D</i> _{1, std}	<i>D</i> _{1, min}	<i>D</i> ₄	<i>D</i> ₆	<i>M</i>	<i>D</i> ₅	<i>L</i> ₇	<i>L</i> ₁	<i>L</i> ₈	<i>L</i> ₉	<i>Q</i> _{gr, real, TD} (cm ³)	<i>Q</i> _{gr, real, TUC} (cm ³)	
362	--	125		145	165	M12	13,5	25	25	130	147,5	85 ~ 128	--	TD_U 8050-11-3
462	--	125		145	165	M12	13,5	25	25	130	147,5	108 ~ 163	--	TD_U 8050-11-4
562	--	125		145	165	M12	13,5	25	25	130	147,5	133 ~ 199	--	TD_U 8050-11-5
144	--	130		150	170	M12	13,5	40	25	135	152,5	69 ~ 104	--	TD_B 8016-12-2
176	--	130		150	170	M12	13,5	40	25	135	152,5	79 ~ 118	--	TD_B 8016-12-3
208	--	130		150	170	M12	13,5	40	25	135	152,5	88 ~ 132	--	TD_B 8016-12-4
240	--	130		150	170	M12	13,5	40	25	135	152,5	98 ~ 147	--	TD_B 8016-12-5
272	--	130		150	170	M12	13,5	40	25	135	152,5	109 ~ 163	--	TD_B 8016-12-6
320	--	130		150	170	M12	13,5	40	25	135	152,5	133 ~ 199	--	TD_B 8016-12-7
352	--	130		150	170	M12	13,5	40	25	135	152,5	142 ~ 212	--	TD_B 8016-12-8
384	--	130		150	170	M12	13,5	40	25	135	152,5	152 ~ 228	--	TD_B 8016-12-9
416	--	130		150	170	M12	13,5	40	25	135	152,5	161 ~ 241	--	TD_B 8016-12-10
448	--	130		150	170	M12	13,5	40	25	135	152,5	173 ~ 259	--	TD_B 8016-12-11
480	--	130		150	170	M12	13,5	40	25	135	152,5	183 ~ 274	--	TD_B 8016-12-12
518	--	130		150	170	M12	13,5	40	25	135	152,5	196 ~ 294	--	TD_B 8016-12-13
550	--	130		150	170	M12	13,5	40	25	135	152,5	206 ~ 309	--	TD_B 8016-12-14
582	--	130		150	170	M12	13,5	40	25	135	152,5	217 ~ 325	--	TD_B 8016-12-15
614	--	130		150	170	M12	13,5	40	25	135	152,5	227 ~ 340	--	TD_B 8016-12-16
646	--	130		150	170	M12	13,5	40	25	135	152,5	239 ~ 359	--	TD_B 8016-12-17
678	--	130		150	170	M12	13,5	40	25	135	152,5	250 ~ 374	--	TD_B 8016-12-18
180	--	135	(130)	155 (150)	175 (170)	M12	13,5	25	25	140 (135)	157,5 (152,5)	71 ~ 107	--	TD_U 8020-12-2
220	--	135	(130)	155 (150)	175 (170)	M12	13,5	25	25	140 (135)	157,5 (152,5)	83 ~ 125	--	TD_U 8020-12-3
260	--	135	(130)	155 (150)	175 (170)	M12	13,5	25	25	140 (135)	157,5 (152,5)	95 ~ 143	--	TD_U 8020-12-4
300	--	135	(130)	155 (150)	175 (170)	M12	13,5	25	25	140 (135)	157,5 (152,5)	107 ~ 161	--	TD_U 8020-12-5
340	--	135	(130)	155 (150)	175 (170)	M12	13,5	25	25	140 (135)	157,5 (152,5)	120 ~ 180	--	TD_U 8020-12-6
380	--	135	(130)	155 (150)	175 (170)	M12	13,5	25	25	140 (135)	157,5 (152,5)	134 ~ 201	--	TD_U 8020-12-7
420	--	135	(130)	155 (150)	175 (170)	M12	13,5	25	25	140 (135)	157,5 (152,5)	148 ~ 223	--	TD_U 8020-12-8
208	--	135	(130)	155 (150)	175 (170)	M12	13,5	25	25	140 (135)	157,5 (152,5)	77 ~ 116	--	TD_U 8025-12-2
258	--	135	(130)	155 (150)	175 (170)	M12	13,5	25	25	140 (135)	157,5 (152,5)	93 ~ 139	--	TD_U 8025-12-3
308	--	135	(130)	155 (150)	175 (170)	M12	13,5	25	25	140 (135)	157,5 (152,5)	108 ~ 162	--	TD_U 8025-12-4
358	--	135	(130)	155 (150)	175 (170)	M12	13,5	25	25	140 (135)	157,5 (152,5)	123 ~ 184	--	TD_U 8025-12-5
408	--	135	(130)	155 (150)	175 (170)	M12	13,5	25	25	140 (135)	157,5 (152,5)	139 ~ 208	--	TD_U 8025-12-6
458	--	135	(130)	155 (150)	175 (170)	M12	13,5	25	25	140 (135)	157,5 (152,5)	155 ~ 233	--	TD_U 8025-12-7
508	--	135	(130)	155 (150)	175 (170)	M12	13,5	25	25	140 (135)	157,5 (152,5)	172 ~ 259	--	TD_U 8025-12-8
208	--	135	(130)	155 (150)	175 (170)	M12	13,5	25	25	140 (135)	157,5 (152,5)	70 ~ 104	--	TD_U 8030-12-2
268	--	135	(130)	155 (150)	175 (170)	M12	13,5	25	25	140 (135)	157,5 (152,5)	88 ~ 132	--	TD_U 8030-12-3
328	--	135	(130)	155 (150)	175 (170)	M12	13,5	25	25	140 (135)	157,5 (152,5)	106 ~ 159	--	TD_U 8030-12-4
388	--	135	(130)	155 (150)	175 (170)	M12	13,5	25	25	140 (135)	157,5 (152,5)	124 ~ 186	--	TD_U 8030-12-5
448	--	135	(130)	155 (150)	175 (170)	M12	13,5	25	25	140 (135)	157,5 (152,5)	143 ~ 215	--	TD_U 8030-12-6
508	--	135	(130)	155 (150)	175 (170)	M12	13,5	25	25	140 (135)	157,5 (152,5)	163 ~ 244	--	TD_U 8030-12-7
568	--	135	(130)	155 (150)	175 (170)	M12	13,5	25	25	140 (135)	157,5 (152,5)	183 ~ 275	--	TD_U 8030-12-8

Key dimensions of the cylindrical nut: N, M, Y are obtained in the tables of page 38 of the catalogue.

SHUTON advises to use the dimensions of the tables, although it is possible to manufacture ball screw with other dimensions.

Smaller nut diameters than the first option of the table can reduce the rigidity of the assembly between 5 and 10%.

Please consult SHUTON.

COMPLEX, Double Nut (1start), Ultracompact Nut

Ball screw reference	Nominal diameter	Lead	Ball diameter	Root diameter	Circuits	Dynamic load capacity	Static load capacity	Rigidity of ball contact zone, with Fpr:10%Ca	Rigidity of nut, with Fpr:10%Ca
TDB Flanged double nut TDL Cylindrical double nut TDBC Centre flanged double nut TUCB Flanged Ultracompact nut TUCL Cylindrical Ultracompact nut	d_0	P_h	D_w	d_2	$i (I_e)$	$C_a(N)$	$C_{oa} (N)$	$R_{b/t,pr} (N/\mu m)$	$R_{nu} (N/\mu m)$
TD_-U 8040-12-2	80	40	12,7	71	2	129200	263500	2400	2340
TD_-U 8040-12-3	80	40	12,7	71	3	180800	417200	3610	3520
TD_-U 8040-12-4	80	40	12,7	71	4	232500	570900	4810	4700
TD_-U 8040-12-5	80	40	12,7	71	5	283100	724600	6010	5870
TD_-U 8040-12-6	80	40	12,7	71	6	332600	878300	7150	6980
TD_-U 8050-12-2	80	50	12,7	71	2	128100	261800	2370	2320
TD_-U 8050-12-3	80	50	12,7	71	3	179400	414600	3560	3490
TD_-U 8050-12-4	80	50	12,7	71	4	230600	567300	4750	4660
TD_-U 8050-12-5	80	50	12,7	71	5	280800	720000	5930	5820
TD_-B 8020-15-2	80	20	15,875	67	2	173200	323500	2220	2120
TD_-B 8020-15-3	80	20	15,875	67	3	243300	515200	3400	3240
TD_-B 8020-15-4	80	20	15,875	67	4	317000	718900	4650	4430
TD_-B 8020-15-5	80	20	15,875	67	5	385400	910600	5750	5490
TD_-B 8020-15-6	80	20	15,875	67	6	455600	1114300	6870	6550
TD_-B 8020-15-7	80	20	15,875	67	7	521100	1306000	7910	7550
TD_-B 8020-15-8	80	20	15,875	67	8	569700	1437900	8970	8560
TD_-B 8020-15-9	80	20	15,875	67	9	633300	1629600	10050	9590
TD_-B 8020-15-10	80	20	15,875	67	10	695800	1821300	11120	10620
TD_-B 8020-15-11	80	20	15,875	67	11	757500	2013000	12090	11550
TD_-B 8020-15-12	80	20	15,875	67	12	824300	2228700	13290	12690
TD_-B 8020-15-13	80	20	15,875	67	13	884400	2420400	14250	13610
TD_-B 8020-15-14	80	20	15,875	67	14	943900	2612100	15300	14620
TD_-B 8025-19-2	80	25	19,05	64,1	2	204800	354600	2190	2120
TD_-B 8025-19-3	80	25	19,05	64,1	3	296600	591000	3470	3350
TD_-B 8025-19-4	80	25	19,05	64,1	4	387200	827400	4660	4500
TD_-B 8025-19-5	80	25	19,05	64,1	5	475600	1063900	5910	5710
TD_-B 8025-19-6	80	25	19,05	64,1	6	561800	1300300	7020	6780
TD_-B 8025-19-7	80	25	19,05	64,1	7	641400	1519800	8090	7820
TD_-B 8025-19-8	80	25	19,05	64,1	8	724200	1756200	9110	8810
TD_-B 8025-19-9	80	25	19,05	64,1	9	805500	1992600	10130	9800
TD_-B 8025-19-10	80	25	19,05	64,1	10	858600	2127700	11430	11040
TD_-B 8025-19-11	80	25	19,05	64,1	11	938000	2364100	12570	12140
TD_-B 8025-19-12	80	25	19,05	64,1	12	1016300	2600600	13570	13120
TD_-U 10012-8-2	100	12	7,938	93,3	2	77600	210500	2760	2500
TD_-U 10012-8-3	100	12	7,938	93,3	3	106700	324400	4080	3690
TD_-U 10012-8-4	100	12	7,938	93,3	4	136000	438200	5360	4860
TD_-U 10015-8-2	100	15	7,938	93,3	2	77600	210500	2760	2550
TD_-U 10015-8-3	100	15	7,938	93,3	3	106600	324200	4070	3760
TD_-U 10015-8-4	100	15	7,938	93,3	4	135900	438000	5360	4950
TD_-U 10016-8-2	100	16	7,938	93,3	2	77600	210400	2760	2560
TD_-U 10016-8-3	100	16	7,938	93,3	3	106600	324200	4070	3780

* C_a and C_{oa} : Modified static and dynamic load capacities, calculated according to DIN 69051/4 standard and ISO3408/5. See pages 39 and 43.

** $R_{b/t,pr}$: Rigidity of the balls contact zone for an external force 10% of C_a . See page 47. For a different preload force, multiply by $\sqrt[3]{F_{pr}/0,1 C_a}$

*** R_{nu} : Total rigidity of the complete nut. It must be multiplied by the factor $f_{a'}$, which depends on the manufacturing tolerance. See page 48.

Nut length 1 start	Nut length 2 starts	Nut dimensions										Grease quantity TD 'steel ball'	Grease quantity TUC 'steel ball'	Ball screw reference
		$D_{1, std}$	$D_{1, min}$	D_4	D_6	M	D_5	L_7	L_1	L_8	L_9			
TDB	TUC											$Q_{gr, real, TD}$ (cm^3)	$Q_{gr, real, TUC}$ (cm^3)	
254	--	135	(130)	155 (150)	175 (170)	M12	13,5	25	25	140 (135)	157,5 (152,5)	81 ~ 122	--	TD_U 8040-12-2
334	--	135	(130)	155 (150)	175 (170)	M12	13,5	25	25	140 (135)	157,5 (152,5)	105 ~ 158	--	TD_U 8040-12-3
414	--	135	(130)	155 (150)	175 (170)	M12	13,5	25	25	140 (135)	157,5 (152,5)	130 ~ 195	--	TD_U 8040-12-4
494	--	135	(130)	155 (150)	175 (170)	M12	13,5	25	25	140 (135)	157,5 (152,5)	154 ~ 231	--	TD_U 8040-12-5
574	--	135	(130)	155 (150)	175 (170)	M12	13,5	25	25	140 (135)	157,5 (152,5)	179 ~ 269	--	TD_U 8040-12-6
274	--	135	(130)	155 (150)	175 (170)	M12	13,5	25	25	140 (135)	157,5 (152,5)	83 ~ 124	--	TD_U 8050-12-2
374	--	135	(130)	155 (150)	175 (170)	M12	13,5	25	25	140 (135)	157,5 (152,5)	113 ~ 170	--	TD_U 8050-12-3
474	--	135	(130)	155 (150)	175 (170)	M12	13,5	25	25	140 (135)	157,5 (152,5)	144 ~ 216	--	TD_U 8050-12-4
574	--	135	(130)	155 (150)	175 (170)	M12	13,5	25	25	140 (135)	157,5 (152,5)	174 ~ 262	--	TD_U 8050-12-5
175	--	140		166	192	M16	17,5	45	25	145	168,5	112 ~ 168	--	TD_B 8020-15-2
215	--	140		166	192	M16	17,5	45	25	145	168,5	128 ~ 192	--	TD_B 8020-15-3
255	--	140		166	192	M16	17,5	45	25	145	168,5	143 ~ 214	--	TD_B 8020-15-4
295	--	140		166	192	M16	17,5	45	25	145	168,5	160 ~ 241	--	TD_B 8020-15-5
335	--	140		166	192	M16	17,5	45	25	145	168,5	178 ~ 267	--	TD_B 8020-15-6
375	--	140		166	192	M16	17,5	45	25	145	168,5	197 ~ 295	--	TD_B 8020-15-7
435	--	140		166	192	M16	17,5	45	25	145	168,5	231 ~ 347	--	TD_B 8020-15-8
475	--	140		166	192	M16	17,5	45	25	145	168,5	249 ~ 373	--	TD_B 8020-15-9
515	--	140		166	192	M16	17,5	45	25	145	168,5	266 ~ 399	--	TD_B 8020-15-10
555	--	140		166	192	M16	17,5	45	25	145	168,5	286 ~ 430	--	TD_B 8020-15-11
595	--	140		166	192	M16	17,5	45	25	145	168,5	301 ~ 452	--	TD_B 8020-15-12
635	--	140		166	192	M16	17,5	45	25	145	168,5	321 ~ 482	--	TD_B 8020-15-13
675	--	140		166	192	M16	17,5	45	25	145	168,5	339 ~ 508	--	TD_B 8020-15-14
212	--	150		176	202	M16	17,5	50	40	155	178,5	163 ~ 244	--	TD_B 8025-19-2
262	--	150		176	202	M16	17,5	50	40	155	178,5	185 ~ 278	--	TD_B 8025-19-3
312	--	150		176	202	M16	17,5	50	40	155	178,5	210 ~ 315	--	TD_B 8025-19-4
362	--	150		176	202	M16	17,5	50	40	155	178,5	232 ~ 348	--	TD_B 8025-19-5
412	--	150		176	202	M16	17,5	50	40	155	178,5	260 ~ 389	--	TD_B 8025-19-6
462	--	150		176	202	M16	17,5	50	40	155	178,5	287 ~ 430	--	TD_B 8025-19-7
512	--	150		176	202	M16	17,5	50	40	155	178,5	316 ~ 475	--	TD_B 8025-19-8
562	--	150		176	202	M16	17,5	50	40	155	178,5	346 ~ 519	--	TD_B 8025-19-9
637	--	150		176	202	M16	17,5	50	40	155	178,5	388 ~ 582	--	TD_B 8025-19-10
687	--	150		176	202	M16	17,5	50	40	155	178,5	413 ~ 620	--	TD_B 8025-19-11
710	--	150		176	202	M16	17,5	50	40	155	178,5	414 ~ 620	--	TD_B 8025-19-12
128	--	150	(135)	176 (155)	202 (175)	M16 (M12)	17,5 (13,5)	30	25	155 (140)	178,5 (157,5)	39 ~ 59	--	TD_U 10012-8-2
152	--	150	(135)	176 (155)	202 (175)	M16 (M12)	17,5 (13,5)	30	25	155 (140)	178,5 (157,5)	45 ~ 67	--	TD_U 10012-8-3
176	--	150	(135)	176 (155)	202 (175)	M16 (M12)	17,5 (13,5)	30	25	155 (140)	178,5 (157,5)	50 ~ 75	--	TD_U 10012-8-4
134	--	150	(135)	176 (155)	202 (175)	M16 (M12)	17,5 (13,5)	30	25	155 (140)	178,5 (157,5)	35 ~ 52	--	TD_U 10015-8-2
164	--	150	(135)	176 (155)	202 (175)	M16 (M12)	17,5 (13,5)	30	25	155 (140)	178,5 (157,5)	41 ~ 62	--	TD_U 10015-8-3
194	--	150	(135)	176 (155)	202 (175)	M16 (M12)	17,5 (13,5)	30	25	155 (140)	178,5 (157,5)	48 ~ 72	--	TD_U 10015-8-4
140	--	150	(135)	176 (155)	202 (175)	M16 (M12)	17,5 (13,5)	30	25	155 (140)	178,5 (157,5)	35 ~ 53	--	TD_U 10016-8-2
172	--	150	(135)	176 (155)	202 (175)	M16 (M12)	17,5 (13,5)	30	25	155 (140)	178,5 (157,5)	42 ~ 63	--	TD_U 10016-8-3

Key dimensions of the cylindrical nut: N, M, Y are obtained in the tables of page 38 of the catalogue.

SHUTON advises to use the dimensions of the tables, although it is possible to manufacture ball screw with other dimensions.

Smaller nut diameters than the first option of the table can reduce the rigidity of the assembly between 5 and 10%.

Please consult SHUTON.

COMPLEX, Double Nut (1start), Ultracompact Nut

Ball screw reference	Nominal diameter	Lead	Ball diameter	Root diameter	Circuits	Dynamic load capacity	Static load capacity	Rigidity of ball contact zone, with Fpr:10%Ca	Rigidity of nut, with Fpr:10%Ca
TDB Flanged double nut TDL Cylindrical double nut TDBC Centre flanged double nut TUCB Flanged Ultracompact nut TUCL Cylindrical Ultracompact nut	d_0	P_h	D_w	d_2	$i (I_e)$	$C_a(N)$	$C_{oa} (N)$	$R_{b/t,pr} (N/\mu m)$	$R_{nu} (N/\mu m)$
TD_-U 10016-8-4	100	16	7,938	93,3	4	135900	437900	5360	4970
TD_-B 10012,7-9-2	100	12,7	9,525	92,2	2	99500	251600	2820	2500
TD_-B 10012,7-9-3	100	12,7	9,525	92,2	3	137800	391900	4170	3720
TD_-B 10012,7-9-4	100	12,7	9,525	92,2	4	169800	503200	5340	4780
TD_-B 10012,7-9-5	100	12,7	9,525	92,2	5	207800	643500	6660	5960
TD_-B 10012,7-9-6	100	12,7	9,525	92,2	6	244900	783700	8030	7180
TD_-B 10012,7-9-7	100	12,7	9,525	92,2	7	274400	891000	9130	8180
TD_-B 10012,7-9-8	100	12,7	9,525	92,2	8	309400	1027100	10410	9340
TD_-B 10012,7-9-9	100	12,7	9,525	92,2	9	346200	1175600	11800	10570
TD_-B 10012,7-9-10	100	12,7	9,525	92,2	10	375100	1287000	12870	11550
TD_-B 10012,7-9-11	100	12,7	9,525	92,2	11	407700	1419000	14180	12730
TD_-B 10012,7-9-12	100	12,7	9,525	92,2	12	443000	1567500	15530	13930
TD_-B 10012,7-9-13	100	12,7	9,525	92,2	13	469400	1670600	16530	14860
TD_-B 10012,7-9-14	100	12,7	9,525	92,2	14	503200	1815000	17940	16110
TD_-B 10012,7-9-15	100	12,7	9,525	92,2	15	536600	1959300	19200	17250
TD_-U 10016-9-2	100	16	9,525	92,2	2	99500	251500	2810	2600
TD_-U 10016-9-3	100	16	9,525	92,2	3	137700	391700	4170	3850
TD_-U 10016-9-4	100	16	9,525	92,2	4	175200	527700	5480	5070
TD_-U 10016-9-5	100	16	9,525	92,2	5	213000	667900	6800	6290
TD_-U 10020-9-2	100	20	9,525	92,2	2	99400	251300	2810	2630
TD_-U 10020-9-3	100	20	9,525	92,2	3	137600	391400	4160	3910
TD_-U 10020-9-4	100	20	9,525	92,2	4	175100	527400	5480	5140
TD_-U 10020-9-5	100	20	9,525	92,2	5	212800	667500	6790	6380
TD_-U/TUC_-B 10025-9-2	100	25	9,525	92,2	2	99200	251100	2800	2660
TD_-U/TUC_-B 10025-9-3	100	25	9,525	92,2	3	137400	391000	4160	3950
TD_-U/TUC_-B 10025-9-4	100	25	9,525	92,2	4	174800	526800	5460	5190
TD_-U/TUC_-B 10025-9-5	100	25	9,525	92,2	5	212500	666700	6770	6440
TD_/TUC_-U 10030-9-2	100	30	9,525	92,2	2	99100	250700	2790	2680
TD_/TUC_-U 10030-9-3	100	30	9,525	92,2	3	137200	390500	4140	3970
TD_/TUC_-U 10030-9-4	100	30	9,525	92,2	4	175400	530200	5490	5260
TD_/TUC_-U 10030-9-5	100	30	9,525	92,2	5	212100	665800	6760	6480
TD_/TUC_-U 10040-9-2	100	40	9,525	92,2	2	98600	249900	2770	2690
TD_/TUC_-U 10040-9-3	100	40	9,525	92,2	3	136600	389200	4110	3980
TD_/TUC_-U 10040-9-4	100	40	9,525	92,2	4	174700	528400	5450	5280
TD_/TUC_-U 10040-9-5	100	40	9,525	92,2	5	212000	667700	6750	6540
TD_/TUC_-U 10050-9-2	100	50	9,525	92,2	2	99100	252900	2790	2720
TD_/TUC_-U 10050-9-3	100	50	9,525	92,2	3	136700	391600	4120	4010
TD_/TUC_-U 10050-9-4	100	50	9,525	92,2	4	174600	530200	5440	5300
TD_/TUC_-U 10050-9-5	100	50	9,525	92,2	5	211700	668900	6730	6560
TD_-B 10016-12-2	100	16	12,7	91	2	146400	336200	2930	2710
TD_-B 10016-12-3	100	16	12,7	91	3	204500	530400	4470	4130

* Ca and Coa: Modified static and dynamic load capacities, calculated according to DIN 69051/4 standard and ISO3408/5. See pages 39 and 43.

** Rb/t,pr: Rigidity of the balls contact zone for an external force 10% of Ca. See page 47. For a different preload force, multiply by $\sqrt[3]{F_{pr}/0,1 C_a}$

*** Rnu: Total rigidity of the complete nut. It must be multiplied by the factor $f_{a'}$, which depends on the manufacturing tolerance. See page 48.

Nut length 1 start	Nut length 2 starts	Nut dimensions										Grease quantity TD 'steel ball'	Grease quantity TUC 'steel ball'	Ball screw reference
		$D_{1, std}$	$D_{1, min}$	D_4	D_6	M	D_5	L_7	L_1	L_8	L_9			
TDB	TUC											$Q_{gr, real, TD}$ (cm^3)	$Q_{gr, real, TUC}$ (cm^3)	
206	--	150	(135)	176 (155)	202 (175)	M16 (M12)	17,5 (13,5)	30	25	155 (140)	178,5 (157,5)	49 ~ 74	--	TD_U 10016-8-4
127	--	140		166	192	M16	17,5	35	25	145	168,5	55 ~ 83	--	TD_B 10012,7-9-2
153	--	140		166	192	M16	17,5	35	25	145	168,5	63 ~ 94	--	TD_B 10012,7-9-3
191	--	140		166	192	M16	17,5	35	25	145	168,5	80 ~ 120	--	TD_B 10012,7-9-4
216	--	140		166	192	M16	17,5	35	25	145	168,5	87 ~ 131	--	TD_B 10012,7-9-5
242	--	140		166	192	M16	17,5	35	25	145	168,5	95 ~ 142	--	TD_B 10012,7-9-6
269	--	140		166	192	M16	17,5	35	25	145	168,5	104 ~ 157	--	TD_B 10012,7-9-7
295	--	140		166	192	M16	17,5	35	25	145	168,5	112 ~ 169	--	TD_B 10012,7-9-8
320	--	140		166	192	M16	17,5	35	25	145	168,5	119 ~ 178	--	TD_B 10012,7-9-9
346	--	140		166	192	M16	17,5	35	25	145	168,5	128 ~ 192	--	TD_B 10012,7-9-10
372	--	140		166	192	M16	17,5	35	25	145	168,5	136 ~ 204	--	TD_B 10012,7-9-11
397	--	140		166	192	M16	17,5	35	25	145	168,5	142 ~ 214	--	TD_B 10012,7-9-12
423	--	140		166	192	M16	17,5	35	25	145	168,5	152 ~ 228	--	TD_B 10012,7-9-13
449	--	140		166	192	M16	17,5	35	25	145	168,5	159 ~ 238	--	TD_B 10012,7-9-14
474	--	140		166	192	M16	17,5	35	25	145	168,5	166 ~ 249	--	TD_B 10012,7-9-15
146	--	150	(140)	176 (166)	202 (192)	M16	17,5	30	25	155 (145)	178,5 (168,5)	49 ~ 74	--	TD_U 10016-9-2
178	--	150	(140)	176 (166)	202 (192)	M16	17,5	30	25	155 (145)	178,5 (168,5)	58 ~ 87	--	TD_U 10016-9-3
210	--	150	(140)	176 (166)	202 (192)	M16	17,5	30	25	155 (145)	178,5 (168,5)	67 ~ 100	--	TD_U 10016-9-4
242	--	150	(140)	176 (166)	202 (192)	M16	17,5	30	25	155 (145)	178,5 (168,5)	76 ~ 114	--	TD_U 10016-9-5
160	--	150	(140)	176 (166)	202 (192)	M16	17,5	30	25	155 (145)	178,5 (168,5)	48 ~ 72	--	TD_U 10020-9-2
200	--	150	(140)	176 (166)	202 (192)	M16	17,5	30	25	155 (145)	178,5 (168,5)	58 ~ 87	--	TD_U 10020-9-3
240	--	150	(140)	176 (166)	202 (192)	M16	17,5	30	25	155 (145)	178,5 (168,5)	69 ~ 103	--	TD_U 10020-9-4
280	--	150	(140)	176 (166)	202 (192)	M16	17,5	30	25	155 (145)	178,5 (168,5)	80 ~ 120	--	TD_U 10020-9-5
178	92	150	(140)	176 (166)	202 (192)	M16	17,5	30	25	155 (145)	178,5 (168,5)	48 ~ 72	33 ~ 49	TD_U/TUC_B 10025-9-2
228	117	150	(140)	176 (166)	202 (192)	M16	17,5	30	25	155 (145)	178,5 (168,5)	61 ~ 91	40 ~ 60	TD_U/TUC_B 10025-9-3
278	154	150	(140)	176 (166)	202 (192)	M16	17,5	30	25	155 (145)	178,5 (168,5)	74 ~ 111	57 ~ 85	TD_U/TUC_B 10025-9-4
328	179	150	(140)	176 (166)	202 (192)	M16	17,5	30	25	155 (145)	178,5 (168,5)	87 ~ 130	64 ~ 96	TD_U/TUC_B 10025-9-5
196	102	150	(140)	176 (166)	202 (192)	M16	17,5	30	25	155 (145)	178,5 (168,5)	50 ~ 75	26 ~ 39	TD_U/TUC_U 10030-9-2
256	132	150	(140)	176 (166)	202 (192)	M16	17,5	30	25	155 (145)	178,5 (168,5)	65 ~ 97	34 ~ 52	TD_U/TUC_U 10030-9-3
316	162	150	(140)	176 (166)	202 (192)	M16	17,5	30	25	155 (145)	178,5 (168,5)	79 ~ 119	43 ~ 64	TD_U/TUC_U 10030-9-4
376	192	150	(140)	176 (166)	202 (192)	M16	17,5	30	25	155 (145)	178,5 (168,5)	95 ~ 142	52 ~ 78	TD_U/TUC_U 10030-9-5
247	115	150	(140)	176 (166)	202 (192)	M16	17,5	30	25	155 (145)	178,5 (168,5)	60 ~ 90	26 ~ 39	TD_U/TUC_U 10040-9-2
327	155	150	(140)	176 (166)	202 (192)	M16	17,5	30	25	155 (145)	178,5 (168,5)	79 ~ 119	36 ~ 54	TD_U/TUC_U 10040-9-3
407	195	150	(140)	176 (166)	202 (192)	M16	17,5	30	25	155 (145)	178,5 (168,5)	98 ~ 148	47 ~ 70	TD_U/TUC_U 10040-9-4
487	235	150	(140)	176 (166)	202 (192)	M16	17,5	30	25	155 (145)	178,5 (168,5)	118 ~ 177	57 ~ 86	TD_U/TUC_U 10040-9-5
268	133	150	(140)	176 (166)	202 (192)	M16	17,5	30	25	155 (145)	178,5 (168,5)	61 ~ 91	28 ~ 43	TD_U/TUC_U 10050-9-2
368	183	150	(140)	176 (166)	202 (192)	M16	17,5	30	25	155 (145)	178,5 (168,5)	84 ~ 126	41 ~ 62	TD_U/TUC_U 10050-9-3
468	233	150	(140)	176 (166)	202 (192)	M16	17,5	30	25	155 (145)	178,5 (168,5)	107 ~ 161	54 ~ 81	TD_U/TUC_U 10050-9-4
568	283	150	(140)	176 (166)	202 (192)	M16	17,5	30	25	155 (145)	178,5 (168,5)	131 ~ 197	67 ~ 100	TD_U/TUC_U 10050-9-5
144	--	155	(150)	181 (176)	207 (202)	M16	17,5	40	25	160 (155)	183,5 (178,5)	85 ~ 127	--	TD_B 10016-12-2
176	--	155	(150)	181 (176)	207 (202)	M16	17,5	40	25	160 (155)	183,5 (178,5)	95 ~ 143	--	TD_B 10016-12-3

Key dimensions of the cylindrical nut: N, M, Y are obtained in the tables of page 38 of the catalogue.

SHUTON advises to use the dimensions of the tables, although it is possible to manufacture ball screw with other dimensions.

Smaller nut diameters than the first option of the table can reduce the rigidity of the assembly between 5 and 10%.

Please consult SHUTON.

COMPLEX, Double Nut (1start), Ultracompact Nut

Ball screw reference	Nominal diameter	Lead	Ball diameter	Root diameter	Circuits	Dynamic load capacity	Static load capacity	Rigidity of ball contact zone, with Fpr:10%Ca	Rigidity of nut, with Fpr:10%Ca
TDB Flanged double nut TDL Cylindrical double nut TDBC Centre flanged double nut TUCB Flanged Ultracompact nut TUCL Cylindrical Ultracompact nut	d_0	P_h	D_w	d_2	$i (Ie)$	$C_a(N)$	$C_{oa} (N)$	$R_{b/t,pr} (N/\mu m)$	$R_{nu} (N/\mu m)$
TD_-B 10016-12-4	100	16	12,7	91	4	262600	724700	5910	5460
TD_-B 10016-12-5	100	16	12,7	91	5	307300	866600	7120	6600
TD_-B 10016-12-6	100	16	12,7	91	6	363400	1060800	8590	7960
TD_-B 10016-12-7	100	16	12,7	91	7	418200	1255100	9970	9230
TD_-B 10016-12-8	100	16	12,7	91	8	472000	1449300	11420	10570
TD_-B 10016-12-9	100	16	12,7	91	9	513600	1591300	12640	11720
TD_-B 10016-12-10	100	16	12,7	91	10	562700	1770600	13920	12920
TD_-B 10016-12-11	100	16	12,7	91	11	615800	1972300	15360	14250
TD_-B 10016-12-12	100	16	12,7	91	12	668100	2174000	16800	15580
TD_-B 10016-12-13	100	16	12,7	91	13	704600	2301000	17850	16580
TD_-B 10016-12-14	100	16	12,7	91	14	757400	2510200	19280	17910
TD_-B 10016-12-15	100	16	12,7	91	15	803700	2689500	20670	19190
TD_-B 10016-12-16	100	16	12,7	91	16	855400	2898700	22090	20510
TD_-U 10020-12-2	100	20	12,7	91	2	146300	336000	2920	2730
TD_-U 10020-12-3	100	20	12,7	91	3	204300	530100	4460	4170
TD_-U 10020-12-4	100	20	12,7	91	4	262400	724200	5910	5520
TD_-U 10020-12-5	100	20	12,7	91	5	317500	910800	7280	6810
TD_-U 10020-12-6	100	20	12,7	91	6	373200	1104900	8660	8100
TD_-U 10020-12-7	100	20	12,7	91	7	427700	1299000	9990	9350
TD_-U 10025-12-2	100	25	12,7	91	2	146100	335600	2920	2760
TD_-U 10025-12-3	100	25	12,7	91	3	204000	529500	4450	4210
TD_-U 10025-12-4	100	25	12,7	91	4	262000	723400	5890	5580
TD_-U 10025-12-5	100	25	12,7	91	5	318800	917300	7320	6930
TD_-U 10025-12-6	100	25	12,7	91	6	372700	1103800	8640	8190
TD_-U 10025-12-7	100	25	12,7	91	7	427100	1297700	9970	9450
TD_-U 10030-12-2	100	30	12,7	91	2	145800	335200	2910	2780
TD_-U 10030-12-3	100	30	12,7	91	3	203700	528800	4440	4240
TD_-U 10030-12-4	100	30	12,7	91	4	261600	722500	5880	5610
TD_-U 10030-12-5	100	30	12,7	91	5	318300	916200	7300	6980
TD_-U 10030-12-6	100	30	12,7	91	6	373700	1109800	8670	8290
TD_-U 10030-12-7	100	30	12,7	91	7	426400	1296000	9940	9510
TD_-U 10040-12-2	100	40	12,7	91	2	145200	334100	2890	2790
TD_-U 10040-12-3	100	40	12,7	91	3	202800	527100	4410	4260
TD_-U 10040-12-4	100	40	12,7	91	4	260500	720200	5840	5640
TD_-U 10040-12-5	100	40	12,7	91	5	316900	913200	7250	7010
TD_-U 10040-12-6	100	40	12,7	91	6	372200	1106200	8620	8330
TD_-U 10050-12-2	100	50	12,7	91	2	146600	340100	2930	2850
TD_-U 10050-12-3	100	50	12,7	91	3	203600	532300	4430	4310
TD_-U 10050-12-4	100	50	12,7	91	4	260800	724600	5840	5680
TD_-U 10050-12-5	100	50	12,7	91	5	316900	916800	7250	7050
TD_-B 10020-15-2	100	20	15,875	87	2	196700	413400	2730	2580

* C_a and C_{oa} : Modified static and dynamic load capacities, calculated according to DIN 69051/4 standard and ISO3408/5. See pages 39 and 43.

** $R_{b/t,pr}$: Rigidity of the balls contact zone for an external force 10% of C_a . See page 47. For a different preload force, multiply by $\sqrt[3]{F_{pr}/0,1 C_a}$

*** R_{nu} : Total rigidity of the complete nut. It must be multiplied by the factor $f_{a'}$, which depends on the manufacturing tolerance. See page 48.

Nut length 1 start	Nut length 2 starts	Nut dimensions										Grease quantity TD 'steel ball'	Grease quantity TUC 'steel ball'	Ball screw reference
		$D_{1, std}$	$D_{1, min}$	D_4	D_6	M	D_5	L_7	L_1	L_8	L_9			
<i>TDB</i>	<i>TUC</i>											$Q_{gr, real, TD}$ (cm^3)	$Q_{gr, real, TUC}$ (cm^3)	
208	--	155	(150)	181 (176)	207 (202)	M16	17,5	40	25	160 (155)	183,5 (178,5)	108 ~ 162	--	TD_B 10016-12-4
256	--	155	(150)	181 (176)	207 (202)	M16	17,5	40	25	160 (155)	183,5 (178,5)	136 ~ 205	--	TD_B 10016-12-5
288	--	155	(150)	181 (176)	207 (202)	M16	17,5	40	25	160 (155)	183,5 (178,5)	148 ~ 222	--	TD_B 10016-12-6
320	--	155	(150)	181 (176)	207 (202)	M16	17,5	40	25	160 (155)	183,5 (178,5)	161 ~ 241	--	TD_B 10016-12-7
352	--	155	(150)	181 (176)	207 (202)	M16	17,5	40	25	160 (155)	183,5 (178,5)	172 ~ 259	--	TD_B 10016-12-8
390	--	155	(150)	181 (176)	207 (202)	M16	17,5	40	25	160 (155)	183,5 (178,5)	191 ~ 287	--	TD_B 10016-12-9
422	--	155	(150)	181 (176)	207 (202)	M16	17,5	40	25	160 (155)	183,5 (178,5)	205 ~ 308	--	TD_B 10016-12-10
454	--	155	(150)	181 (176)	207 (202)	M16	17,5	40	25	160 (155)	183,5 (178,5)	217 ~ 325	--	TD_B 10016-12-11
486	--	155	(150)	181 (176)	207 (202)	M16	17,5	40	25	160 (155)	183,5 (178,5)	228 ~ 342	--	TD_B 10016-12-12
520	--	155	(150)	181 (176)	207 (202)	M16	17,5	40	25	160 (155)	183,5 (178,5)	246 ~ 369	--	TD_B 10016-12-13
552	--	155	(150)	181 (176)	207 (202)	M16	17,5	40	25	160 (155)	183,5 (178,5)	257 ~ 386	--	TD_B 10016-12-14
584	--	155	(150)	181 (176)	207 (202)	M16	17,5	40	25	160 (155)	183,5 (178,5)	269 ~ 403	--	TD_B 10016-12-15
616	--	155	(150)	181 (176)	207 (202)	M16	17,5	40	25	160 (155)	183,5 (178,5)	280 ~ 420	--	TD_B 10016-12-16
181	--	150		176	202	M16	17,5	30	25	155	178,5	88 ~ 132	--	TD_U 10020-12-2
221	--	150		176	202	M16	17,5	30	25	155	178,5	102 ~ 153	--	TD_U 10020-12-3
261	--	150		176	202	M16	17,5	30	25	155	178,5	117 ~ 176	--	TD_U 10020-12-4
301	--	150		176	202	M16	17,5	30	25	155	178,5	133 ~ 200	--	TD_U 10020-12-5
341	--	150		176	202	M16	17,5	30	25	155	178,5	149 ~ 224	--	TD_U 10020-12-6
381	--	150		176	202	M16	17,5	30	25	155	178,5	166 ~ 249	--	TD_U 10020-12-7
194	--	150		176	202	M16	17,5	30	25	155	178,5	85 ~ 128	--	TD_U 10025-12-2
244	--	150		176	202	M16	17,5	30	25	155	178,5	103 ~ 154	--	TD_U 10025-12-3
294	--	150		176	202	M16	17,5	30	25	155	178,5	122 ~ 183	--	TD_U 10025-12-4
344	--	150		176	202	M16	17,5	30	25	155	178,5	141 ~ 211	--	TD_U 10025-12-5
394	--	150		176	202	M16	17,5	30	25	155	178,5	161 ~ 242	--	TD_U 10025-12-6
444	--	150		176	202	M16	17,5	30	25	155	178,5	182 ~ 273	--	TD_U 10025-12-7
212	--	150		176	202	M16	17,5	30	25	155	178,5	88 ~ 132	--	TD_U 10030-12-2
272	--	150		176	202	M16	17,5	30	25	155	178,5	109 ~ 164	--	TD_U 10030-12-3
332	--	150		176	202	M16	17,5	30	25	155	178,5	132 ~ 199	--	TD_U 10030-12-4
392	--	150		176	202	M16	17,5	30	25	155	178,5	155 ~ 233	--	TD_U 10030-12-5
452	--	150		176	202	M16	17,5	30	25	155	178,5	179 ~ 268	--	TD_U 10030-12-6
512	--	150		176	202	M16	17,5	30	25	155	178,5	204 ~ 306	--	TD_U 10030-12-7
256	--	150		176	202	M16	17,5	30	25	155	178,5	102 ~ 152	--	TD_U 10040-12-2
336	--	150		176	202	M16	17,5	30	25	155	178,5	131 ~ 196	--	TD_U 10040-12-3
416	--	150		176	202	M16	17,5	30	25	155	178,5	161 ~ 242	--	TD_U 10040-12-4
496	--	150		176	202	M16	17,5	30	25	155	178,5	192 ~ 288	--	TD_U 10040-12-5
576	--	150		176	202	M16	17,5	30	25	155	178,5	223 ~ 335	--	TD_U 10040-12-6
280	--	150		176	202	M16	17,5	30	25	155	178,5	105 ~ 157	--	TD_U 10050-12-2
380	--	150		176	202	M16	17,5	30	25	155	178,5	142 ~ 212	--	TD_U 10050-12-3
480	--	150		176	202	M16	17,5	30	25	155	178,5	180 ~ 270	--	TD_U 10050-12-4
580	--	150		176	202	M16	17,5	30	25	155	178,5	218 ~ 327	--	TD_U 10050-12-5
175	--	165	(160)	191 (186)	217 (212)	M16	17,5	45	40	170 (165)	193,5 (188,5)	138 ~ 206	--	TD_B 10020-15-2

Key dimensions of the cylindrical nut: N, M, Y are obtained in the tables of page 38 of the catalogue.

SHUTON advises to use the dimensions of the tables, although it is possible to manufacture ball screw with other dimensions.

Smaller nut diameters than the first option of the table can reduce the rigidity of the assembly between 5 and 10%.

Please consult SHUTON.

COMPLEX, Double Nut (1start), Ultracompact Nut

Ball screw reference	Nominal diameter	Lead	Ball diameter	Root diameter	Circuits	Dynamic load capacity	Static load capacity	Rigidity of ball contact zone, with Fpr:10%Ca	Rigidity of nut, with Fpr:10%Ca
TDB Flanged double nut TDL Cylindrical double nut TDBC Centre flanged double nut TUCB Flanged Ultracompact nut TUCL Cylindrical Ultracompact nut	d_0	P_h	D_w	d_2	$i (I_e)$	$C_a (N)$	$C_{oa} (N)$	$R_{b/t,pr} (N/\mu m)$	$R_{nu} (N/\mu m)$
TD_-B 10020-15-3	100	20	15,875	87	3	279300	668700	4190	3940
TD_-B 10020-15-4	100	20	15,875	87	4	358200	911800	5570	5240
TD_-B 10020-15-5	100	20	15,875	87	5	438600	1167100	7010	6590
TD_-B 10020-15-6	100	20	15,875	87	6	496300	1337300	8060	7600
TD_-B 10020-15-7	100	20	15,875	87	7	570800	1580500	9520	8970
TD_-B 10020-15-8	100	20	15,875	87	8	643900	1823600	10750	10140
TD_-B 10020-15-9	100	20	15,875	87	9	721300	2091100	12220	11520
TD_-B 10020-15-10	100	20	15,875	87	10	791900	2334300	13550	12770
TD_-B 10020-15-11	100	20	15,875	87	11	847900	2516600	14690	13860
TD_-B 10020-15-12	100	20	15,875	87	12	911500	2735500	15820	14940
TD_-B 10025-19-2	100	25	19,05	84,1	2	244300	481500	2780	2660
TD_-B 10025-19-3	100	25	19,05	84,1	3	345400	773800	4300	4110
TD_-B 10025-19-4	100	25	19,05	84,1	4	446100	1066200	5740	5480
TD_-B 10025-19-5	100	25	19,05	84,1	5	544600	1358500	7160	6850
TD_-B 10025-19-6	100	25	19,05	84,1	6	640900	1650800	8580	8200
TD_-B 10025-19-7	100	25	19,05	84,1	7	735100	1943200	9850	9430
TD_-B 10025-19-8	100	25	19,05	84,1	8	801900	2132300	11070	10600
TD_-B 10025-19-9	100	25	19,05	84,1	9	897600	2441900	12550	12010
TD_-B 12012,7-9-2	120	12,7	9,525	112,2	2	108700	307000	3290	2830
TD_-B 12012,7-9-3	120	12,7	9,525	112,2	3	149500	472900	4850	4180
TD_-B 12012,7-9-4	120	12,7	9,525	112,2	4	185500	614000	6240	5400
TD_-B 12012,7-9-5	120	12,7	9,525	112,2	5	226000	779900	7820	6760
TD_-B 12012,7-9-6	120	12,7	9,525	112,2	6	265600	945800	9330	8080
TD_-B 12012,7-9-7	120	12,7	9,525	112,2	7	299100	1082700	10650	9250
TD_-B 12012,7-9-8	120	12,7	9,525	112,2	8	338700	1257000	12250	10620
TD_-B 12012,7-9-9	120	12,7	9,525	112,2	9	375500	1418700	13720	11910
TD_-B 12012,7-9-10	120	12,7	9,525	112,2	10	408100	1559800	15110	13130
TD_-B 12012,7-9-11	120	12,7	9,525	112,2	11	444500	1725700	16580	14420
TD_-B 12012,7-9-12	120	12,7	9,525	112,2	12	480500	1891700	18040	15690
TD_-B 12016-12-2	120	16	12,7	111	2	161600	413900	3490	3150
TD_-B 12016-12-3	120	16	12,7	111	3	224300	647200	5230	4730
TD_-B 12016-12-4	120	16	12,7	111	4	285700	872900	6870	6210
TD_-B 12016-12-5	120	16	12,7	111	5	336300	1053500	8300	7530
TD_-B 12016-12-6	120	16	12,7	111	6	398700	1294400	10070	9120
TD_-B 12016-12-7	120	16	12,7	111	7	456600	1520100	11630	10550
TD_-B 12016-12-8	120	16	12,7	111	8	513500	1745900	13270	12030
TD_-B 12016-12-9	120	16	12,7	111	9	563600	1941500	14800	13440
TD_-B 12016-12-10	120	16	12,7	111	10	618800	2167300	16380	14880
TD_-B 12016-12-11	120	16	12,7	111	11	673200	2393000	17950	16310
TD_-B 12016-12-12	120	16	12,7	111	12	726900	2618800	19520	17740
TD_-U 12020-12-2	120	20	12,7	111	2	161500	413700	3490	3190

* Ca and Coa: Modified static and dynamic load capacities, calculated according to DIN 69051/4 standard and ISO3408/5. See pages 39 and 43.

** Rb/t,pr: Rigidity of the balls contact zone for an external force 10% of Ca. See page 47. For a different preload force, multiply by $\sqrt[3]{F_{pr}/0,1 C_a}$

*** Rnu: Total rigidity of the complete nut. It must be multiplied by the factor $f_{a'}$, which depends on the manufacturing tolerance. See page 48.

Nut length 1 start	Nut length 2 starts	Nut dimensions										Grease quantity TD 'steel ball'	Grease quantity TUC 'steel ball'	Ball screw reference	
		$D_{1, std}$	$D_{1, min}$	D_4	D_6	M	D_5	L_7	L_1	L_8	L_9				$Q_{gr, real, TD}$ (cm^3)
TDB	TUC														
215	--	165	(160)	191 (186)	217 (212)	M16	17,5	45	40	170 (165)	193,5 (188,5)	157 ~ 235	--	TD_B 10020-15-3	
255	--	165	(160)	191 (186)	217 (212)	M16	17,5	45	40	170 (165)	193,5 (188,5)	178 ~ 267	--	TD_B 10020-15-4	
295	--	165	(160)	191 (186)	217 (212)	M16	17,5	45	40	170 (165)	193,5 (188,5)	197 ~ 296	--	TD_B 10020-15-5	
355	--	165	(160)	191 (186)	217 (212)	M16	17,5	45	40	170 (165)	193,5 (188,5)	246 ~ 370	--	TD_B 10020-15-6	
395	--	165	(160)	191 (186)	217 (212)	M16	17,5	45	40	170 (165)	193,5 (188,5)	264 ~ 396	--	TD_B 10020-15-7	
435	--	165	(160)	191 (186)	217 (212)	M16	17,5	45	40	170 (165)	193,5 (188,5)	288 ~ 432	--	TD_B 10020-15-8	
475	--	165	(160)	191 (186)	217 (212)	M16	17,5	45	40	170 (165)	193,5 (188,5)	306 ~ 459	--	TD_B 10020-15-9	
515	--	165	(160)	191 (186)	217 (212)	M16	17,5	45	40	170 (165)	193,5 (188,5)	326 ~ 490	--	TD_B 10020-15-10	
562	--	165	(160)	191 (186)	217 (212)	M16	17,5	45	40	170 (165)	193,5 (188,5)	358 ~ 537	--	TD_B 10020-15-11	
602	--	165	(160)	191 (186)	217 (212)	M16	17,5	45	40	170 (165)	193,5 (188,5)	383 ~ 574	--	TD_B 10020-15-12	
212	--	175	(170)	201 (196)	227 (222)	M16	17,5	50	40	180 (175)	203,5 (198,5)	198 ~ 298	--	TD_B 10025-19-2	
262	--	175	(170)	201 (196)	227 (222)	M16	17,5	50	40	180 (175)	203,5 (198,5)	226 ~ 339	--	TD_B 10025-19-3	
312	--	175	(170)	201 (196)	227 (222)	M16	17,5	50	40	180 (175)	203,5 (198,5)	257 ~ 385	--	TD_B 10025-19-4	
362	--	175	(170)	201 (196)	227 (222)	M16	17,5	50	40	180 (175)	203,5 (198,5)	287 ~ 431	--	TD_B 10025-19-5	
412	--	175	(170)	201 (196)	227 (222)	M16	17,5	50	40	180 (175)	203,5 (198,5)	318 ~ 476	--	TD_B 10025-19-6	
462	--	175	(170)	201 (196)	227 (222)	M16	17,5	50	40	180 (175)	203,5 (198,5)	353 ~ 529	--	TD_B 10025-19-7	
537	--	175	(170)	201 (196)	227 (222)	M16	17,5	50	40	180 (175)	203,5 (198,5)	419 ~ 628	--	TD_B 10025-19-8	
587	--	175	(170)	201 (196)	227 (222)	M16	17,5	50	40	180 (175)	203,5 (198,5)	447 ~ 670	--	TD_B 10025-19-9	
127	--	160		186	212	M16	17,5	35	25	165	188,5	66 ~ 99	--	TD_B 12012,7-9-2	
153	--	160		186	212	M16	17,5	35	25	165	188,5	75 ~ 113	--	TD_B 12012,7-9-3	
191	--	160		186	212	M16	17,5	35	25	165	188,5	95 ~ 143	--	TD_B 12012,7-9-4	
216	--	160		186	212	M16	17,5	35	25	165	188,5	103 ~ 155	--	TD_B 12012,7-9-5	
242	--	160		186	212	M16	17,5	35	25	165	188,5	113 ~ 169	--	TD_B 12012,7-9-6	
269	--	160		186	212	M16	17,5	35	25	165	188,5	124 ~ 186	--	TD_B 12012,7-9-7	
295	--	160		186	212	M16	17,5	35	25	165	188,5	133 ~ 199	--	TD_B 12012,7-9-8	
320	--	160		186	212	M16	17,5	35	25	165	188,5	142 ~ 212	--	TD_B 12012,7-9-9	
346	--	160		186	212	M16	17,5	35	25	165	188,5	151 ~ 227	--	TD_B 12012,7-9-10	
372	--	160		186	212	M16	17,5	35	25	165	188,5	161 ~ 241	--	TD_B 12012,7-9-11	
397	--	160		186	212	M16	17,5	35	25	165	188,5	170 ~ 255	--	TD_B 12012,7-9-12	
144	--	175	(170)	201 (196)	227 (222)	M16	17,5	40	25	180 (175)	203,5 (198,5)	100 ~ 149	--	TD_B 12016-12-2	
176	--	175	(170)	201 (196)	227 (222)	M16	17,5	40	25	180 (175)	203,5 (198,5)	113 ~ 170	--	TD_B 12016-12-3	
208	--	175	(170)	201 (196)	227 (222)	M16	17,5	40	25	180 (175)	203,5 (198,5)	128 ~ 192	--	TD_B 12016-12-4	
256	--	175	(170)	201 (196)	227 (222)	M16	17,5	40	25	180 (175)	203,5 (198,5)	162 ~ 243	--	TD_B 12016-12-5	
288	--	175	(170)	201 (196)	227 (222)	M16	17,5	40	25	180 (175)	203,5 (198,5)	175 ~ 262	--	TD_B 12016-12-6	
320	--	175	(170)	201 (196)	227 (222)	M16	17,5	40	25	180 (175)	203,5 (198,5)	190 ~ 286	--	TD_B 12016-12-7	
352	--	175	(170)	201 (196)	227 (222)	M16	17,5	40	25	180 (175)	203,5 (198,5)	205 ~ 307	--	TD_B 12016-12-8	
390	--	175	(170)	201 (196)	227 (222)	M16	17,5	40	25	180 (175)	203,5 (198,5)	226 ~ 339	--	TD_B 12016-12-9	
422	--	175	(170)	201 (196)	227 (222)	M16	17,5	40	25	180 (175)	203,5 (198,5)	241 ~ 361	--	TD_B 12016-12-10	
454	--	175	(170)	201 (196)	227 (222)	M16	17,5	40	25	180 (175)	203,5 (198,5)	256 ~ 384	--	TD_B 12016-12-11	
486	--	175	(170)	201 (196)	227 (222)	M16	17,5	40	25	180 (175)	203,5 (198,5)	271 ~ 406	--	TD_B 12016-12-12	
182	--	170		196	222	M16	17,5	30	25	175	198,5	105 ~ 157	--	TD_U 12020-12-2	

Key dimensions of the cylindrical nut: N, M, Y are obtained in the tables of page 38 of the catalogue.

SHUTON advises to use the dimensions of the tables, although it is possible to manufacture ball screw with other dimensions.

Smaller nut diameters than the first option of the table can reduce the rigidity of the assembly between 5 and 10%.

Please consult SHUTON.

COMPLEX, Double Nut (1start), Ultracompact Nut

Ball screw reference	Nominal diameter	Lead	Ball diameter	Root diameter	Circuits	Dynamic load capacity	Static load capacity	Rigidity of ball contact zone, with Fpr:10%Ca	Rigidity of nut, with Fpr:10%Ca
TDB Flanged double nut TDL Cylindrical double nut TDBC Centre flanged double nut TUCB Flanged Ultracompact nut TUCL Cylindrical Ultracompact nut	d_0	P_h	D_w	d_2	$i (I_e)$	$C_a(N)$	$C_{oa} (N)$	$R_{b/t,pr} (N/\mu m)$	$R_{nu} (N/\mu m)$
TD_-U 12020-12-3	120	20	12,7	111	3	224200	646900	5230	4780
TD_-U 12020-12-4	120	20	12,7	111	4	285500	872500	6870	6290
TD_-U 12020-12-5	120	20	12,7	111	5	347300	1105700	8510	7800
TD_-U 12020-12-6	120	20	12,7	111	6	407700	1338900	10090	9260
TD_-U 12025-12-2	120	25	12,7	111	2	161300	413400	3480	3240
TD_-U 12025-12-3	120	25	12,7	111	3	224000	646400	5220	4860
TD_-U 12025-12-4	120	25	12,7	111	4	285200	871900	6860	6390
TD_-U 12025-12-5	120	25	12,7	111	5	346900	1104900	8490	7920
TD_-U 12025-12-6	120	25	12,7	111	6	407300	1337900	10080	9400
TD_-U 12030-12-2	120	30	12,7	111	2	161200	413000	3480	3270
TD_-U 12030-12-3	120	30	12,7	111	3	223700	645800	5210	4910
TD_-U 12030-12-4	120	30	12,7	111	4	286500	878600	6900	6500
TD_-U 12030-12-5	120	30	12,7	111	5	346500	1103900	8480	7990
TD_-U 12030-12-6	120	30	12,7	111	6	406800	1336700	10060	9490
TD_-U 12040-12-2	120	40	12,7	111	2	160700	412100	3460	3310
TD_-U 12040-12-3	120	40	12,7	111	3	223100	644300	5190	4960
TD_-U 12040-12-4	120	40	12,7	111	4	285700	876600	6870	6560
TD_-U 12040-12-5	120	40	12,7	111	5	347100	1108900	8490	8120
TD_-U 12040-12-6	120	40	12,7	111	6	407100	1341100	10060	9630
TD_-U 12050-12-2	120	50	12,7	111	2	160100	410900	3440	3320
TD_-U 12050-12-3	120	50	12,7	111	3	222200	642500	5150	4970
TD_-U 12050-12-4	120	50	12,7	111	4	284600	874000	6820	6580
TD_-U 12050-12-5	120	50	12,7	111	5	345700	1105600	8440	8140
TD_-B 12020-15-2	120	20	15,875	107	2	219900	515500	3290	3050
TD_-B 12020-15-3	120	20	15,875	107	3	309400	822300	5000	4620
TD_-B 12020-15-4	120	20	15,875	107	4	395800	1116900	6570	6080
TD_-B 12020-15-5	120	20	15,875	107	5	483300	1423700	8200	7590
TD_-B 12020-15-6	120	20	15,875	107	6	549900	1644700	9610	8910
TD_-B 12020-15-7	120	20	15,875	107	7	631400	1939200	11200	10380
TD_-B 12020-15-8	120	20	15,875	107	8	711500	2233800	12690	11760
TD_-B 12020-15-9	120	20	15,875	107	9	790100	2528400	14260	13230
TD_-B 12020-15-10	120	20	15,875	107	10	872600	2847500	15860	14710
TD_-B 12025-19-2	120	25	19,05	104,1	2	272000	591600	3310	3130
TD_-B 12025-19-3	120	25	19,05	104,1	3	386300	957000	5080	4800
TD_-B 12025-19-4	120	25	19,05	104,1	4	495400	1305000	6820	6440
TD_-B 12025-19-5	120	25	19,05	104,1	5	606600	1670400	8500	8020
TD_-B 12025-19-6	120	25	19,05	104,1	6	711200	2018400	10080	9530
TD_-B 12025-19-7	120	25	19,05	104,1	7	789500	2262000	11540	10910
TD_-B 14016-12-2	140	16	12,7	131	2	174800	491700	3990	3510
TD_-B 14016-12-3	140	16	12,7	131	3	240100	756400	5920	5220
TD_-B 14016-12-4	140	16	12,7	131	4	307400	1028700	7810	6900

* C_a and C_{oa} : Modified static and dynamic load capacities, calculated according to DIN 69051/4 standard and ISO3408/5. See pages 39 and 43.

** $R_{b/t,pr}$: Rigidity of the balls contact zone for an external force 10% of C_a . See page 47. For a different preload force, multiply by $\sqrt[3]{F_{pr}/0,1 C_a}$

*** R_{nu} : Total rigidity of the complete nut. It must be multiplied by the factor f_{ar} , which depends on the manufacturing tolerance. See page 48.

Nut length 1 start	Nut length 2 starts	Nut dimensions										Grease quantity TD 'steel ball'	Grease quantity TUC 'steel ball'	Ball screw reference
		$D_{1, std}$	$D_{1, min}$	D_4	D_6	M	D_5	L_7	L_1	L_8	L_9			
TDB	TUC											$Q_{gr, real, TD}$ (cm^3)	$Q_{gr, real, TUC}$ (cm^3)	
222	--	170		196	222	M16	17,5	30	25	175	198,5	122 ~ 183	--	TD_U 12020-12-3
262	--	170		196	222	M16	17,5	30	25	175	198,5	140 ~ 210	--	TD_U 12020-12-4
302	--	170		196	222	M16	17,5	30	25	175	198,5	159 ~ 238	--	TD_U 12020-12-5
342	--	170		196	222	M16	17,5	30	25	175	198,5	178 ~ 267	--	TD_U 12020-12-6
196	--	170		196	222	M16	17,5	30	25	175	198,5	102 ~ 153	--	TD_U 12025-12-2
246	--	170		196	222	M16	17,5	30	25	175	198,5	123 ~ 185	--	TD_U 12025-12-3
296	--	170		196	222	M16	17,5	30	25	175	198,5	146 ~ 220	--	TD_U 12025-12-4
346	--	170		196	222	M16	17,5	30	25	175	198,5	170 ~ 254	--	TD_U 12025-12-5
396	--	170		196	222	M16	17,5	30	25	175	198,5	193 ~ 290	--	TD_U 12025-12-6
214	--	170		196	222	M16	17,5	30	25	175	198,5	105 ~ 158	--	TD_U 12030-12-2
274	--	170		196	222	M16	17,5	30	25	175	198,5	131 ~ 197	--	TD_U 12030-12-3
334	--	170		196	222	M16	17,5	30	25	175	198,5	158 ~ 237	--	TD_U 12030-12-4
394	--	170		196	222	M16	17,5	30	25	175	198,5	187 ~ 280	--	TD_U 12030-12-5
454	--	170		196	222	M16	17,5	30	25	175	198,5	215 ~ 322	--	TD_U 12030-12-6
258	--	170		196	222	M16	17,5	30	25	175	198,5	121 ~ 182	--	TD_U 12040-12-2
338	--	170		196	222	M16	17,5	30	25	175	198,5	156 ~ 234	--	TD_U 12040-12-3
418	--	170		196	222	M16	17,5	30	25	175	198,5	192 ~ 288	--	TD_U 12040-12-4
498	--	170		196	222	M16	17,5	30	25	175	198,5	229 ~ 344	--	TD_U 12040-12-5
578	--	170		196	222	M16	17,5	30	25	175	198,5	266 ~ 400	--	TD_U 12040-12-6
284	--	170		196	222	M16	17,5	30	25	175	198,5	127 ~ 190	--	TD_U 12050-12-2
384	--	170		196	222	M16	17,5	30	25	175	198,5	171 ~ 257	--	TD_U 12050-12-3
484	--	170		196	222	M16	17,5	30	25	175	198,5	216 ~ 325	--	TD_U 12050-12-4
584	--	170		196	222	M16	17,5	30	25	175	198,5	262 ~ 393	--	TD_U 12050-12-5
175	--	185		211	237	M16	17,5	45	40	190	213,5	162 ~ 243	--	TD_B 12020-15-2
215	--	185		211	237	M16	17,5	45	40	190	213,5	184 ~ 277	--	TD_B 12020-15-3
255	--	185		211	237	M16	17,5	45	40	190	213,5	210 ~ 315	--	TD_B 12020-15-4
295	--	185		211	237	M16	17,5	45	40	190	213,5	234 ~ 351	--	TD_B 12020-15-5
355	--	185		211	237	M16	17,5	45	40	190	213,5	288 ~ 432	--	TD_B 12020-15-6
395	--	185		211	237	M16	17,5	45	40	190	213,5	312 ~ 468	--	TD_B 12020-15-7
435	--	185		211	237	M16	17,5	45	40	190	213,5	339 ~ 508	--	TD_B 12020-15-8
475	--	185		211	237	M16	17,5	45	40	190	213,5	363 ~ 544	--	TD_B 12020-15-9
515	--	185		211	237	M16	17,5	45	40	190	213,5	387 ~ 580	--	TD_B 12020-15-10
212	--	195	(190)	221 (216)	247 (242)	M16	17,5	50	40	200 (195)	223,5 (218,5)	234 ~ 351	--	TD_B 12025-19-2
262	--	195	(190)	221 (216)	247 (242)	M16	17,5	50	40	200 (195)	223,5 (218,5)	268 ~ 402	--	TD_B 12025-19-3
312	--	195	(190)	221 (216)	247 (242)	M16	17,5	50	40	200 (195)	223,5 (218,5)	301 ~ 452	--	TD_B 12025-19-4
362	--	195	(190)	221 (216)	247 (242)	M16	17,5	50	40	200 (195)	223,5 (218,5)	337 ~ 506	--	TD_B 12025-19-5
412	--	195	(190)	221 (216)	247 (242)	M16	17,5	50	40	200 (195)	223,5 (218,5)	376 ~ 563	--	TD_B 12025-19-6
487	--	195	(190)	221 (216)	247 (242)	M16	17,5	50	40	200 (195)	223,5 (218,5)	454 ~ 681	--	TD_B 12025-19-7
144	--	195	(190)	221 (216)	247 (242)	M16	17,5	40	40	200 (195)	223,5 (218,5)	115 ~ 173	--	TD_B 14016-12-2
176	--	195	(190)	221 (216)	247 (242)	M16	17,5	40	40	200 (195)	223,5 (218,5)	131 ~ 197	--	TD_B 14016-12-3
208	--	195	(190)	221 (216)	247 (242)	M16	17,5	40	40	200 (195)	223,5 (218,5)	148 ~ 222	--	TD_B 14016-12-4

Key dimensions of the cylindrical nut: N, M, Y are obtained in the tables of page 38 of the catalogue.

SHUTON advises to use the dimensions of the tables, although it is possible to manufacture ball screw with other dimensions.

Smaller nut diameters than the first option of the table can reduce the rigidity of the assembly between 5 and 10%.

Please consult SHUTON.

COMPLEX, Double Nut (1start), Ultracompact Nut

Ball screw reference	Nominal diameter	Lead	Ball diameter	Root diameter	Circuits	Dynamic load capacity	Static load capacity	Rigidity of ball contact zone, with Fpr:10%Ca	Rigidity of nut, with Fpr:10%Ca
TDB Flanged double nut TDL Cylindrical double nut TDBC Centre flanged double nut TUCB Flanged Ultracompact nut TUCL Cylindrical Ultracompact nut	d_0	P_h	D_w	d_2	$i (I_e)$	$C_a(N)$	$C_{oa} (N)$	$R_{b/t,pr} (N/\mu m)$	$R_{nu} (N/\mu m)$
TD_-B 14016-12-5	140	16	12,7	131	5	364700	1255700	9530	8440
TD_-B 14016-12-6	140	16	12,7	131	6	426700	1512800	11370	10080
TD_-B 14016-12-7	140	16	12,7	131	7	490300	1785200	13230	11730
TD_-B 14016-12-8	140	16	12,7	131	8	552600	2057500	15070	13370
TD_-B 14016-12-9	140	16	12,7	131	9	603200	2269300	16730	14860
TD_-B 14016-12-10	140	16	12,7	131	10	663700	2541600	18590	16510
TD_-B 14016-12-11	140	16	12,7	131	11	723400	2813900	20450	18160
TD_-B 14016-12-12	140	16	12,7	131	12	782200	3086200	22180	19710
TD_-B 14020-15-2	140	20	15,875	127	2	240000	617800	3780	3450
TD_-B 14020-15-3	140	20	15,875	127	3	335500	976100	5720	5210
TD_-B 14020-15-4	140	20	15,875	127	4	428400	1322100	7530	6870
TD_-B 14020-15-5	140	20	15,875	127	5	501500	1581600	9030	8270
TD_-B 14020-15-6	140	20	15,875	127	6	596300	1952300	11000	10060
TD_-B 14020-15-7	140	20	15,875	127	7	684000	2298200	12820	11730
TD_-B 14020-15-8	140	20	15,875	127	8	770100	2644200	14540	13310
TD_-B 14020-15-9	140	20	15,875	127	9	842900	2928400	16170	14820
TD_-B 14025-19-2	140	25	19,05	124,1	2	300800	719300	3910	3660
TD_-B 14025-19-3	140	25	19,05	124,1	3	421500	1140400	5900	5510
TD_-B 14025-19-4	140	25	19,05	124,1	4	538000	1543900	7800	7290
TD_-B 14025-19-5	140	25	19,05	124,1	5	656300	1965000	9700	9070
TD_-B 14025-19-6	140	25	19,05	124,1	6	749100	2280800	11350	10620
TD_-B 16020-15-2	160	20	15,875	147	2	257800	720200	4300	3850
TD_-B 16020-15-3	160	20	15,875	147	3	358700	1130000	6420	5740
TD_-B 16020-15-4	160	20	15,875	147	4	439900	1440400	8160	7330
TD_-B 16020-15-5	160	20	15,875	147	5	537400	1837800	10240	9200
TD_-B 16020-15-6	160	20	15,875	147	6	637500	2260000	12340	11080
TD_-B 16020-15-7	160	20	15,875	147	7	714700	2570400	14040	12650
TD_-B 16025-19-2	160	25	19,05	144,1	2	321700	829700	4340	4000
TD_-B 16025-19-3	160	25	19,05	144,1	3	448600	1306300	6550	6040
TD_-B 16025-19-4	160	25	19,05	144,1	4	575800	1782900	8740	8060
TD_-B 16025-19-5	160	25	19,05	144,1	5	678300	2153600	10500	9710

* C_a and C_{oa} : Modified static and dynamic load capacities, calculated according to DIN 69051/4 standard and ISO3408/5. See pages 39 and 43.

** $R_{b/t,pr}$: Rigidity of the balls contact zone for an external force 10% of C_a . See page 47. For a different preload force, multiply by $\sqrt[3]{F_{pr}/0,1 C_a}$

*** R_{nu} : Total rigidity of the complete nut. It must be multiplied by the factor $f_{a,r}$, which depends on the manufacturing tolerance. See page 48.

Nut length 1 start	Nut length 2 starts	Nut dimensions										Grease quantity TD 'steel ball'	Grease quantity TUC 'steel ball'	Ball screw reference	
		$D_{1, std}$	$D_{1, min}$	D_4	D_6	M	D_5	L_7	L_1	L_8	L_9				$Q_{gr, real, TD}$ (cm^3)
TDB	TUC														
256	--	195	(190)	221 (216)	247 (242)	M16	17,5	40	40	200 (195)	223,5 (218,5)	186 ~ 280	--	TD_B 14016-12-5	
288	--	195	(190)	221 (216)	247 (242)	M16	17,5	40	40	200 (195)	223,5 (218,5)	203 ~ 305	--	TD_B 14016-12-6	
320	--	195	(190)	221 (216)	247 (242)	M16	17,5	40	40	200 (195)	223,5 (218,5)	220 ~ 330	--	TD_B 14016-12-7	
352	--	195	(190)	221 (216)	247 (242)	M16	17,5	40	40	200 (195)	223,5 (218,5)	237 ~ 355	--	TD_B 14016-12-8	
390	--	195	(190)	221 (216)	247 (242)	M16	17,5	40	40	200 (195)	223,5 (218,5)	263 ~ 394	--	TD_B 14016-12-9	
422	--	195	(190)	221 (216)	247 (242)	M16	17,5	40	40	200 (195)	223,5 (218,5)	279 ~ 418	--	TD_B 14016-12-10	
454	--	195	(190)	221 (216)	247 (242)	M16	17,5	40	40	200 (195)	223,5 (218,5)	295 ~ 442	--	TD_B 14016-12-11	
486	--	195	(190)	221 (216)	247 (242)	M16	17,5	40	40	200 (195)	223,5 (218,5)	313 ~ 470	--	TD_B 14016-12-12	
175	--	210	(205)	236 (231)	262 (257)	M16	17,5	45	40	215 (210)	238,5 (233,5)	187 ~ 281	--	TD_B 14020-15-2	
215	--	210	(205)	236 (231)	262 (257)	M16	17,5	45	40	215 (210)	238,5 (233,5)	213 ~ 320	--	TD_B 14020-15-3	
255	--	210	(205)	236 (231)	262 (257)	M16	17,5	45	40	215 (210)	238,5 (233,5)	242 ~ 363	--	TD_B 14020-15-4	
315	--	210	(205)	236 (231)	262 (257)	M16	17,5	45	40	215 (210)	238,5 (233,5)	308 ~ 462	--	TD_B 14020-15-5	
355	--	210	(205)	236 (231)	262 (257)	M16	17,5	45	40	215 (210)	238,5 (233,5)	332 ~ 499	--	TD_B 14020-15-6	
395	--	210	(205)	236 (231)	262 (257)	M16	17,5	45	40	215 (210)	238,5 (233,5)	360 ~ 540	--	TD_B 14020-15-7	
435	--	210	(205)	236 (231)	262 (257)	M16	17,5	45	40	215 (210)	238,5 (233,5)	390 ~ 585	--	TD_B 14020-15-8	
482	--	210	(205)	236 (231)	262 (257)	M16	17,5	45	40	215 (210)	238,5 (233,5)	431 ~ 646	--	TD_B 14020-15-9	
212	--	220	(215)	246 (241)	272 (267)	M16	17,5	50	40	225 (220)	248,5 (243,5)	267 ~ 401	--	TD_B 14025-19-2	
262	--	220	(215)	246 (241)	272 (267)	M16	17,5	50	40	225 (220)	248,5 (243,5)	307 ~ 460	--	TD_B 14025-19-3	
312	--	220	(215)	246 (241)	272 (267)	M16	17,5	50	40	225 (220)	248,5 (243,5)	348 ~ 522	--	TD_B 14025-19-4	
362	--	220	(215)	246 (241)	272 (267)	M16	17,5	50	40	225 (220)	248,5 (243,5)	390 ~ 585	--	TD_B 14025-19-5	
437	--	220	(215)	246 (241)	272 (267)	M16	17,5	50	40	225 (220)	248,5 (243,5)	482 ~ 723	--	TD_B 14025-19-6	
175	--	230		256	282	M16	17,5	45	40	235	258,5	211 ~ 317	--	TD_B 16020-15-2	
215	--	230		256	282	M16	17,5	45	40	235	258,5	242 ~ 363	--	TD_B 16020-15-3	
275	--	230		256	282	M16	17,5	45	40	235	258,5	316 ~ 473	--	TD_B 16020-15-4	
315	--	230		256	282	M16	17,5	45	40	235	258,5	346 ~ 519	--	TD_B 16020-15-5	
355	--	230		256	282	M16	17,5	45	40	235	258,5	377 ~ 565	--	TD_B 16020-15-6	
402	--	230		256	282	M16	17,5	45	40	235	258,5	427 ~ 641	--	TD_B 16020-15-7	
212	--	240	(235)	266 (261)	292 (287)	M16	17,5	50	40	245 (240)	268,5 (263,5)	306 ~ 459	--	TD_B 16025-19-2	
262	--	240	(235)	266 (261)	292 (287)	M16	17,5	50	40	245 (240)	268,5 (263,5)	350 ~ 526	--	TD_B 16025-19-3	
312	--	240	(235)	266 (261)	292 (287)	M16	17,5	50	40	245 (240)	268,5 (263,5)	395 ~ 593	--	TD_B 16025-19-4	
387	--	240	(235)	266 (261)	292 (287)	M16	17,5	50	40	245 (240)	268,5 (263,5)	505 ~ 757	--	TD_B 16025-19-5	

Key dimensions of the cylindrical nut: N, M, Y are obtained in the tables of page 38 of the catalogue.

SHUTON advises to use the dimensions of the tables, although it is possible to manufacture ball screw with other dimensions.

Smaller nut diameters than the first option of the table can reduce the rigidity of the assembly between 5 and 10%.

Please consult SHUTON.

COMPLEX, Double Nut (2 starts)

Ball screw reference TDB Flanged double nut TDL Cylindrical double nut TDBC Centre flanged double nut	No. Starts	Nominal diameter	Lead	Ball diameter	Root diameter	Circuits	Dynamic load capacity	Static load capacity	Rigidity of ball contact zone, with Fpr:10%Ca	Rigidity of nut, with Fpr:10%Ca
	1/2	d_0	P_h	D_w	d_2	$i (1e)$	$C_d (N)$	$C_{oa} (N)$	$R_{b/t,pr} (N/\mu m)$	$R_{nu} (N/\mu m)$
TD_(2S)-U 3220-6-2	2	32	20	6,35	26,5	2	45100	72600	1360	1310
TD_(2S)-U 3220-6-3	2	32	20	6,35	26,5	3	63400	115600	2080	2010
TD_(2S)-U 3225-6-2	2	32	25	6,35	26,5	2	44500	71900	1330	1300
TD_(2S)-U 3225-6-3	2	32	25	6,35	26,5	3	63600	117100	2080	2030
TD_(2S)-U 3232-6-2	2	32	32	6,35	26,5	2	44600	73200	1330	1300
TD_(2S)-U 4020-6-2	2	40	20	6,35	34,5	2	52900	96100	1740	1670
TD_(2S)-U 4020-6-3	2	40	20	6,35	34,5	3	73700	151000	2600	2490
TD_(2S)-U 4020-6-4	2	40	20	6,35	34,5	4	95300	208700	3530	3380
TD_(2S)-U 4020-6-5	2	40	20	6,35	34,5	5	115700	263600	4350	4160
TD_(2S)-U 4025-6-2	2	40	25	6,35	34,5	2	52400	95500	1720	1660
TD_(2S)-U 4025-6-3	2	40	25	6,35	34,5	3	73900	152800	2610	2520
TD_(2S)-U 4025-6-4	2	40	25	6,35	34,5	4	94500	207300	3490	3360
TD_(2S)-U 4030-6-2	2	40	30	6,35	34,5	2	51900	94700	1690	1650
TD_(2S)-U 4030-6-3	2	40	30	6,35	34,5	3	73200	151500	2570	2500
TD_(2S)-U 4040-6-2	2	40	40	6,35	34,5	2	51600	95500	1670	1630
TD_(2S)-U 4050-6-2	2	40	50	6,35	34,5	2	50900	95800	1620	1600
TD_(2S)-U 4060-6-2	2	40	60	6,35	34,5	2	50000	95700	1570	1550
TD_(2S)-U 4025-8-2	2	40	25	7,938	33,3	2	70400	120700	1840	1780
TD_(2S)-U 4025-8-3	2	40	25	7,938	33,3	3	100500	196800	2880	2790
TD_(2S)-U 4025-8-4	2	40	25	7,938	33,3	4	128900	268300	3850	3730
TD_(2S)-U 4030-8-2	2	40	30	7,938	33,3	2	69700	119800	1810	1770
TD_(2S)-U 4030-8-3	2	40	30	7,938	33,3	3	99500	195200	2830	2770
TD_(2S)-U 4040-8-2	2	40	40	7,938	33,3	2	69700	121900	1800	1770
TD_(2S)-U 4050-8-2	2	40	50	7,938	33,3	2	69200	123300	1770	1740
TD_(2S)-U 4060-8-2	2	40	60	7,938	33,3	2	68300	124100	1720	1700
TD_(2S)-U 5020-6-2	2	50	20	6,35	44,5	2	59900	122700	2110	1990
TD_(2S)-U 5020-6-3	2	50	20	6,35	44,5	3	84200	195300	3250	3060
TD_(2S)-U 5020-6-4	2	50	20	6,35	44,5	4	107600	265000	4280	4020
TD_(2S)-U 5020-6-5	2	50	20	6,35	44,5	5	131300	337600	5330	5020
TD_(2S)-U 5020-6-6	2	50	20	6,35	44,5	6	153800	407300	6310	5940
TD_(2S)-U 5020-6-7	2	50	20	6,35	44,5	7	176500	479800	7290	6870
TD_(2S)-U 5025-6-2	2	50	25	6,35	44,5	2	60500	125000	2140	2040
TD_(2S)-U 5025-6-3	2	50	25	6,35	44,5	3	83700	194400	3220	3070
TD_(2S)-U 5025-6-4	2	50	25	6,35	44,5	4	107800	266700	4280	4070
TD_(2S)-U 5025-6-5	2	50	25	6,35	44,5	5	130600	336100	5290	5030
TD_(2S)-U 5025-6-6	2	50	25	6,35	44,5	6	153700	408300	6300	6000
TD_(2S)-U 5030-6-2	2	50	30	6,35	44,5	2	60100	124400	2120	2030
TD_(2S)-U 5030-6-3	2	50	30	6,35	44,5	3	83900	196200	3230	3100
TD_(2S)-U 5030-6-4	2	50	30	6,35	44,5	4	107000	265300	4230	4060
TD_(2S)-U 5030-6-5	2	50	30	6,35	44,5	5	130400	337100	5270	5060
TD_(2S)-U 5040-6-2	2	50	40	6,35	44,5	2	60000	125500	2100	2040

* C_a and C_{oa} : Modified static and dynamic load capacities, calculated according to DIN 69051/4 standard and ISO3408/5. See pages 39 and 43.

** $R_{b/t,pr}$: Rigidity of the balls contact zone for an external force 10% of C_a . See page 47. For a different preload force, multiply by $\sqrt[3]{F_{pr}/0,1 C_a}$

*** R_{nu} : Total rigidity of the complete nut. It must be multiplied by the factor $f_{a'}$, which depends on the manufacturing tolerance. See page 48.

Nut length 2 starts TD(2S)	Nut Dimensions										Grease quantity TD 'steel ball'	Ball screw reference
	$D_{1, std}$	$D_{1, min}$	D_4	D_6	M	D_5	L_7	L_1	L_8	L_9	$Q_{gr, real, TD}$ (cm^3)	TDB Flanged double nut TDL Cylindrical double nut TDBC Centre flanged double nut
145	56		71	86	M8	9	14	20	65	75,5	9,4 ~ 14	TD_(2S)-U 3220-6-2
185	56		71	86	M8	9	14	20	65	75,5	12 ~ 18	TD_(2S)-U 3220-6-3
167	56		71	86	M8	9	14	20	65	75,5	9,2 ~ 14	TD_(2S)-U 3225-6-2
213	56		71	86	M8	9	14	20	65	75,5	12 ~ 18	TD_(2S)-U 3225-6-3
183	56		71	86	M8	9	14	20	65	75,5	9,2 ~ 14	TD_(2S)-U 3232-6-2
142	65	(63)	78	93	M8	9	18	20	70	81,5	12 ~ 18	TD_(2S)-U 4020-6-2
182	65	(63)	78	93	M8	9	18	20	70	81,5	15 ~ 22	TD_(2S)-U 4020-6-3
222	65	(63)	78	93	M8	9	18	20	70	81,5	17 ~ 26	TD_(2S)-U 4020-6-4
262	65	(63)	78	93	M8	9	18	20	70	81,5	20 ~ 31	TD_(2S)-U 4020-6-5
162	65	(63)	78	93	M8	9	18	20	70	81,5	12 ~ 19	TD_(2S)-U 4025-6-2
212	65	(63)	78	93	M8	9	18	20	70	81,5	16 ~ 24	TD_(2S)-U 4025-6-3
262	65	(63)	78	93	M8	9	18	20	70	81,5	19 ~ 28	TD_(2S)-U 4025-6-4
166	65	(63)	78	93	M8	9	18	20	70	81,5	12 ~ 17	TD_(2S)-U 4030-6-2
226	65	(63)	78	93	M8	9	18	20	70	81,5	15 ~ 23	TD_(2S)-U 4030-6-3
206	65	(63)	78	93	M8	9	18	20	70	81,5	12 ~ 18	TD_(2S)-U 4040-6-2
240	65	(63)	78	93	M8	9	18	20	70	81,5	13 ~ 20	TD_(2S)-U 4050-6-2
276	65	(63)	78	93	M8	9	18	20	70	81,5	14 ~ 21	TD_(2S)-U 4060-6-2
179	70		85	100	M8	9	18	25	75	87,5	19 ~ 28	TD_(2S)-U 4025-8-2
229	70		85	100	M8	9	18	25	75	87,5	23 ~ 35	TD_(2S)-U 4025-8-3
279	70		85	100	M8	9	18	25	75	87,5	28 ~ 42	TD_(2S)-U 4025-8-4
190	70		85	100	M8	9	18	25	75	87,5	18 ~ 27	TD_(2S)-U 4030-8-2
248	70		85	100	M8	9	18	25	75	87,5	23 ~ 34	TD_(2S)-U 4030-8-3
216	70		85	100	M8	9	18	25	75	87,5	19 ~ 28	TD_(2S)-U 4040-8-2
238	70		85	100	M8	9	18	25	75	87,5	19 ~ 29	TD_(2S)-U 4050-8-2
272	70		85	100	M8	9	18	25	75	87,5	21 ~ 31	TD_(2S)-U 4060-8-2
142	75		93	110	M10	11	18	25	85	97,5	15 ~ 22	TD_(2S)-U 5020-6-2
182	75		93	110	M10	11	18	25	85	97,5	18 ~ 27	TD_(2S)-U 5020-6-3
222	75		93	110	M10	11	18	25	85	97,5	22 ~ 33	TD_(2S)-U 5020-6-4
262	75		93	110	M10	11	18	25	85	97,5	25 ~ 38	TD_(2S)-U 5020-6-5
302	75		93	110	M10	11	18	25	85	97,5	29 ~ 44	TD_(2S)-U 5020-6-6
342	75		93	110	M10	11	18	25	85	97,5	33 ~ 50	TD_(2S)-U 5020-6-7
157	75		93	110	M10	11	18	25	85	97,5	15 ~ 23	TD_(2S)-U 5025-6-2
208	75		93	110	M10	11	18	25	85	97,5	19 ~ 29	TD_(2S)-U 5025-6-3
257	75		93	110	M10	11	18	25	85	97,5	23 ~ 35	TD_(2S)-U 5025-6-4
307	75		93	110	M10	11	18	25	85	97,5	28 ~ 42	TD_(2S)-U 5025-6-5
357	75		93	110	M10	11	18	25	85	97,5	32 ~ 48	TD_(2S)-U 5025-6-6
181	75		93	110	M10	11	18	25	85	97,5	16 ~ 25	TD_(2S)-U 5030-6-2
241	75		93	110	M10	11	18	25	85	97,5	21 ~ 31	TD_(2S)-U 5030-6-3
301	75		93	110	M10	11	18	25	85	97,5	26 ~ 38	TD_(2S)-U 5030-6-4
361	75		93	110	M10	11	18	25	85	97,5	30 ~ 45	TD_(2S)-U 5030-6-5
206	75		93	110	M10	11	18	25	85	97,5	16 ~ 23	TD_(2S)-U 5040-6-2

Key dimensions of the cylindrical nut: N, M, Y are obtained in the tables of page 38 of the catalogue.

SHUTON advises to use the dimensions of the tables, although it is possible to manufacture ball screw with other dimensions.

Smaller nut diameters than the first option of the table can reduce the rigidity of the assembly between 5 and 10%.

Please consult SHUTON.

COMPLEX, Double Nut (2 starts)

Ball screw reference TDB Flanged double nut TDL Cylindrical double nut TDBC Centre flanged double nut	No. Starts	Nominal diameter	Lead	Ball diameter	Root diameter	Circuits	Dynamic load capacity	Static load capacity	Rigidity of ball contact zone, with Fpr:10%Ca	Rigidity of nut, with Fpr:10%Ca
	$l/2$	d_0	P_h	D_w	d_2	$i (1e)$	$C_a(N)$	$C_{oa} (N)$	$R_{b/t,pr} (N/\mu m)$	$R_{nu} (N/\mu m)$
TD_(2S)-U 5040-6-3	2	50	40	6,35	44,5	3	83300	196400	3180	3090
TD_(2S)-U 5040-6-4	2	50	40	6,35	44,5	4	106700	267300	4200	4070
TD_(2S)-U 5050-6-2	2	50	50	6,35	44,5	2	58700	123500	2030	1980
TD_(2S)-U 5050-6-3	2	50	50	6,35	44,5	3	82300	195900	3120	3040
TD_(2S)-U 5060-6-2	2	50	60	6,35	44,5	2	58100	123700	1990	1950
TD_(2S)-U 5080-6-2	2	50	80	6,35	44,5	2	57000	125800	1920	1890
TD_(2S)-U 5025-8-2	2	50	25	7,938	43,3	2	82300	159700	2350	2260
TD_(2S)-U 5025-8-3	2	50	25	7,938	43,3	3	114600	251000	3510	3380
TD_(2S)-U 5025-8-4	2	50	25	7,938	43,3	4	148300	346800	4730	4540
TD_(2S)-U 5025-8-5	2	50	25	7,938	43,3	5	181200	442600	5930	5700
TD_(2S)-U 5025-8-6	2	50	25	7,938	43,3	6	212200	533900	7030	6750
TD_(2S)-U 5030-8-2	2	50	30	7,938	43,3	2	81700	158900	2330	2250
TD_(2S)-U 5030-8-3	2	50	30	7,938	43,3	3	115200	254200	3530	3420
TD_(2S)-U 5030-8-4	2	50	30	7,938	43,3	4	147300	345000	4680	4530
TD_(2S)-U 5030-8-5	2	50	30	7,938	43,3	5	180000	440400	5870	5680
TD_(2S)-U 5040-8-2	2	50	40	7,938	43,3	2	81900	161400	2330	2270
TD_(2S)-U 5040-8-3	2	50	40	7,938	43,3	3	114700	255500	3500	3420
TD_(2S)-U 5040-8-4	2	50	40	7,938	43,3	4	147400	349600	4670	4560
TD_(2S)-U 5050-8-2	2	50	50	7,938	43,3	2	80200	158800	2250	2210
TD_(2S)-U 5050-8-3	2	50	50	7,938	43,3	3	113600	255900	3440	3380
TD_(2S)-U 5060-8-2	2	50	60	7,938	43,3	2	79700	160200	2220	2180
TD_(2S)-U 5080-8-2	2	50	80	7,938	43,3	2	77900	161400	2120	2100
TD_(2S)-U 5040-9-2	2	50	40	9,525	42,2	2	101600	187500	2280	2230
TD_(2S)-U 5040-9-3	2	50	40	9,525	42,2	3	142400	297400	3480	3410
TD_(2S)-U 5040-9-4	2	50	40	9,525	42,2	4	185100	413800	4690	4590
TD_(2S)-U 5050-9-2	2	50	50	9,525	42,2	2	99600	184600	2210	2170
TD_(2S)-U 5050-9-3	2	50	50	9,525	42,2	3	141600	299100	3440	3380
TD_(2S)-U 6325-8-2	2	63	25	7,938	56,3	2	94300	208600	2910	2760
TD_(2S)-U 6325-8-3	2	63	25	7,938	56,3	3	131700	329100	4450	4200
TD_(2S)-U 6325-8-4	2	63	25	7,938	56,3	4	167900	445000	5830	5510
TD_(2S)-U 6325-8-5	2	63	25	7,938	56,3	5	204600	565500	7250	6870
TD_(2S)-U 6325-8-6	2	63	25	7,938	56,3	6	240500	686000	8630	8170
TD_(2S)-U 6325-8-7	2	63	25	7,938	56,3	7	275700	806500	9950	9430
TD_(2S)-U 6330-8-2	2	63	30	7,938	56,3	2	93900	207900	2890	2760
TD_(2S)-U 6330-8-3	2	63	30	7,938	56,3	3	131100	328000	4420	4210
TD_(2S)-U 6330-8-4	2	63	30	7,938	56,3	4	168400	448100	5840	5580
TD_(2S)-U 6330-8-5	2	63	30	7,938	56,3	5	204900	568200	7260	6930
TD_(2S)-U 6330-8-6	2	63	30	7,938	56,3	6	239500	683700	8570	8190
TD_(2S)-U 6330-8-7	2	63	30	7,938	56,3	7	274500	803800	9880	9450
TD_(2S)-U 6340-8-2	2	63	40	7,938	56,3	2	94200	210800	2900	2800
TD_(2S)-U 6340-8-3	2	63	40	7,938	56,3	3	130900	329900	4400	4240

* C_a and C_{oa} : Modified static and dynamic load capacities, calculated according to DIN 69051/4 standard and ISO3408/5. See pages 39 and 43.

** $R_{b/t,pr}$: Rigidity of the balls contact zone for an external force 10% of C_a . See page 47. For a different preload force, multiply by $\sqrt[3]{F_{pr}/0,1 C_a}$

*** R_{nu} : Total rigidity of the complete nut. It must be multiplied by the factor $f_{a'}$, which depends on the manufacturing tolerance. See page 48.

Nut length 2 starts	Nut Dimensions										Grease quantity TD 'steel ball'	Ball screw reference TDB Flanged double nut TDL Cylindrical double nut TDBC Centre flanged double nut
	TD(2S)	D _{1,std}	D _{1,min}	D ₄	D ₆	M	D ₅	L ₇	L ₁	L ₈		
286	75		93	110	M10	11	18	25	85	97,5	21 ~ 32	TD_(2S)-U 5040-6-3
366	75		93	110	M10	11	18	25	85	97,5	27 ~ 40	TD_(2S)-U 5040-6-4
247	75		93	110	M10	11	18	25	85	97,5	17 ~ 25	TD_(2S)-U 5050-6-2
346	75		93	110	M10	11	18	25	85	97,5	23 ~ 35	TD_(2S)-U 5050-6-3
282	75		93	110	M10	11	18	25	85	97,5	18 ~ 27	TD_(2S)-U 5060-6-2
354	75		93	110	M10	11	18	25	85	97,5	22 ~ 32	TD_(2S)-U 5080-6-2
174	82		100	118	M10	11	18	25	92	105	23 ~ 34	TD_(2S)-U 5025-8-2
224	82		100	118	M10	11	18	25	92	105	29 ~ 43	TD_(2S)-U 5025-8-3
274	82		100	118	M10	11	18	25	92	105	35 ~ 52	TD_(2S)-U 5025-8-4
324	82		100	118	M10	11	18	25	92	105	40 ~ 60	TD_(2S)-U 5025-8-5
374	82		100	118	M10	11	18	25	92	105	47 ~ 70	TD_(2S)-U 5025-8-6
192	82		100	118	M10	11	18	25	92	105	24 ~ 37	TD_(2S)-U 5030-8-2
252	82		100	118	M10	11	18	25	92	105	31 ~ 46	TD_(2S)-U 5030-8-3
312	82		100	118	M10	11	18	25	92	105	38 ~ 57	TD_(2S)-U 5030-8-4
372	82		100	118	M10	11	18	25	92	105	44 ~ 67	TD_(2S)-U 5030-8-5
210	82		100	118	M10	11	18	25	92	105	23 ~ 34	TD_(2S)-U 5040-8-2
290	82		100	118	M10	11	18	25	92	105	31 ~ 46	TD_(2S)-U 5040-8-3
370	82		100	118	M10	11	18	25	92	105	39 ~ 59	TD_(2S)-U 5040-8-4
246	82		100	118	M10	11	18	25	92	105	25 ~ 37	TD_(2S)-U 5050-8-2
346	82		100	118	M10	11	18	25	92	105	34 ~ 52	TD_(2S)-U 5050-8-3
282	82		100	118	M10	11	18	25	92	105	26 ~ 39	TD_(2S)-U 5060-8-2
352	82		100	118	M10	11	18	25	92	105	31 ~ 46	TD_(2S)-U 5080-8-2
220	90	(85)	108 (103)	125 (120)	M10	11	20	25	95 (90)	110 (105)	32 ~ 48	TD_(2S)-U 5040-9-2
300	90	(85)	108 (103)	125 (120)	M10	11	20	25	95 (90)	110 (105)	43 ~ 64	TD_(2S)-U 5040-9-3
380	90	(85)	108 (103)	125 (120)	M10	11	20	25	95 (90)	110 (105)	51 ~ 76	TD_(2S)-U 5040-9-4
242	90	(85)	108 (103)	125 (120)	M10	11	20	25	95 (90)	110 (105)	34 ~ 51	TD_(2S)-U 5050-9-2
342	90	(85)	108 (103)	125 (120)	M10	11	20	25	95 (90)	110 (105)	47 ~ 70	TD_(2S)-U 5050-9-3
170	95		115	135	M12	13,5	20	25	100	117,5	28 ~ 43	TD_(2S)-U 6325-8-2
220	95		115	135	M12	13,5	20	25	100	117,5	35 ~ 52	TD_(2S)-U 6325-8-3
270	95		115	135	M12	13,5	20	25	100	117,5	43 ~ 64	TD_(2S)-U 6325-8-4
320	95		115	135	M12	13,5	20	25	100	117,5	50 ~ 75	TD_(2S)-U 6325-8-5
370	95		115	135	M12	13,5	20	25	100	117,5	58 ~ 87	TD_(2S)-U 6325-8-6
420	95		115	135	M12	13,5	20	25	100	117,5	66 ~ 99	TD_(2S)-U 6325-8-7
183	95		115	135	M12	13,5	20	25	100	117,5	30 ~ 46	TD_(2S)-U 6330-8-2
243	95		115	135	M12	13,5	20	25	100	117,5	38 ~ 57	TD_(2S)-U 6330-8-3
303	95		115	135	M12	13,5	20	25	100	117,5	47 ~ 70	TD_(2S)-U 6330-8-4
363	95		115	135	M12	13,5	20	25	100	117,5	55 ~ 82	TD_(2S)-U 6330-8-5
423	95		115	135	M12	13,5	20	25	100	117,5	64 ~ 96	TD_(2S)-U 6330-8-6
483	95		115	135	M12	13,5	20	25	100	117,5	73 ~ 110	TD_(2S)-U 6330-8-7
210	95		115	135	M12	13,5	20	25	100	117,5	29 ~ 44	TD_(2S)-U 6340-8-2
290	95		115	135	M12	13,5	20	25	100	117,5	39 ~ 59	TD_(2S)-U 6340-8-3

Key dimensions of the cylindrical nut: N, M, Y are obtained in the tables of page 38 of the catalogue.

SHUTON advises to use the dimensions of the tables, although it is possible to manufacture ball screw with other dimensions.

Smaller nut diameters than the first option of the table can reduce the rigidity of the assembly between 5 and 10%.

Please consult SHUTON.

COMPLEX, Double Nut (2 starts)

Ball screw reference TDB Flanged double nut TDL Cylindrical double nut TDBC Centre flanged double nut	No. Starts	Nominal diameter	Lead	Ball diameter	Root diameter	Circuits	Dynamic load capacity	Static load capacity	Rigidity of ball contact zone, with Fpr:10%Ca	Rigidity of nut, with Fpr:10%Ca
	1/2	d_0	P_h	D_w	d_2	$i (1e)$	$C_d(N)$	$C_{oa} (N)$	$R_{b/t,pr} (N/\mu m)$	$R_{nu} (N/\mu m)$
TD_(2S)-U 6340-8-4	2	63	40	7,938	56,3	4	167700	449000	5800	5600
TD_(2S)-U 6340-8-5	2	63	40	7,938	56,3	5	203800	568100	7190	6950
TD_(2S)-U 6340-8-6	2	63	40	7,938	56,3	6	239100	687300	8530	8240
TD_(2S)-U 6350-8-2	2	63	50	7,938	56,3	2	93000	208600	2840	2760
TD_(2S)-U 6350-8-3	2	63	50	7,938	56,3	3	129200	326500	4300	4180
TD_(2S)-U 6350-8-4	2	63	50	7,938	56,3	4	166600	448900	5730	5570
TD_(2S)-B 6325-9-2	2	63	25	9,525	55,2	2	119400	247800	2970	2820
TD_(2S)-B 6325-9-3	2	63	25	9,525	55,2	3	166100	388500	4430	4200
TD_(2S)-B 6325-9-4	2	63	25	9,525	55,2	4	214700	535900	5950	5640
TD_(2S)-B 6325-9-5	2	63	25	9,525	55,2	5	262200	683200	7460	7070
TD_(2S)-B 6325-9-6	2	63	25	9,525	55,2	6	295200	777000	8510	8090
TD_(2S)-B 6325-9-7	2	63	25	9,525	55,2	7	341000	924400	10000	9500
TD_(2S)-B 6325-9-8	2	63	25	9,525	55,2	8	385900	1071700	11480	10900
TD_(2S)-B 6325-9-9	2	63	25	9,525	55,2	9	430000	1219100	12950	12300
TD_(2S)-U 6330-9-2	2	63	30	9,525	55,2	2	118900	247000	2950	2830
TD_(2S)-U 6330-9-3	2	63	30	9,525	55,2	3	167300	393900	4470	4290
TD_(2S)-U 6330-9-4	2	63	30	9,525	55,2	4	213800	534100	5910	5670
TD_(2S)-U 6330-9-5	2	63	30	9,525	55,2	5	261100	681000	7410	7110
TD_(2S)-U 6330-9-6	2	63	30	9,525	55,2	6	307300	827900	8790	8440
TD_(2S)-U 6330-9-7	2	63	30	9,525	55,2	7	350900	968100	10090	9700
TD_(2S)-U 6330-9-8	2	63	30	9,525	55,2	8	395400	1115000	11410	10970
TD_(2S)-U 6340-9-2	2	63	40	9,525	55,2	2	117700	245000	2900	2810
TD_(2S)-U 6340-9-3	2	63	40	9,525	55,2	3	165500	390700	4390	4260
TD_(2S)-U 6340-9-4	2	63	40	9,525	55,2	4	213300	536400	5880	5700
TD_(2S)-U 6340-9-5	2	63	40	9,525	55,2	5	260000	682100	7350	7130
TD_(2S)-U 6340-9-6	2	63	40	9,525	55,2	6	305700	827800	8710	8450
TD_(2S)-U 6350-9-2	2	63	50	9,525	55,2	2	118200	249100	2910	2840
TD_(2S)-U 6350-9-3	2	63	50	9,525	55,2	3	165200	393300	4370	4260
TD_(2S)-U 6350-9-4	2	63	50	9,525	55,2	4	212200	537500	5820	5680
TD_(2S)-U 6340-11-2	2	63	40	11,113	54,1	2	143000	283500	2860	2780
TD_(2S)-U 6340-11-3	2	63	40	11,113	54,1	3	202600	457200	4440	4300
TD_(2S)-U 6340-11-4	2	63	40	11,113	54,1	4	262000	631000	5940	5750
TD_(2S)-U 6340-11-5	2	63	40	11,113	54,1	5	320000	804700	7430	7200
TD_(2S)-U 6340-11-6	2	63	40	11,113	54,1	6	376700	978400	8850	8570
TD_(2S)-U 6350-11-2	2	63	50	11,113	54,1	2	144100	289700	2890	2820
TD_(2S)-U 6350-11-3	2	63	50	11,113	54,1	3	202600	461700	4430	4310
TD_(2S)-U 6350-11-4	2	63	50	11,113	54,1	4	261000	633700	5890	5750
TD_(2S)-B 6332-12-2	2	63	32	12,7	54	2	170300	324700	3010	2900
TD_(2S)-B 6332-12-3	2	63	32	12,7	54	3	243100	529200	4710	4540
TD_(2S)-B 6332-12-4	2	63	32	12,7	54	4	315300	733600	6400	6160
TD_(2S)-B 6332-12-5	2	63	32	12,7	54	5	382500	926100	7910	7610

* C_d and C_{oa} : Modified static and dynamic load capacities, calculated according to DIN 69051/4 standard and ISO3408/5. See pages 39 and 43.

** $R_{b/t,pr}$: Rigidity of the balls contact zone for an external force 10% of C_d . See page 47. For a different preload force, multiply by $\sqrt[3]{F_{pr}/0,1 C_d}$

*** R_{nu} : Total rigidity of the complete nut. It must be multiplied by the factor $f_{a,r}$, which depends on the manufacturing tolerance. See page 48.

Nut length 2 starts	Nut Dimensions										Grease quantity TD 'steel ball' $Q_{gr,real,TD}$ (cm ³)	Ball screw reference TDB Flanged double nut TDL Cylindrical double nut TDBC Centre flanged double nut
	TD(2S)	$D_{1,std}$	$D_{1,min}$	D_4	D_6	M	D_5	L_7	L_1	L_8		
370	95		115	135	M12	13,5	20	25	100	117,5	50 ~ 75	TD_(2S)-U 6340-8-4
450	95		115	135	M12	13,5	20	25	100	117,5	60 ~ 90	TD_(2S)-U 6340-8-5
530	95		115	135	M12	13,5	20	25	100	117,5	71 ~ 107	TD_(2S)-U 6340-8-6
250	95		115	135	M12	13,5	20	25	100	117,5	33 ~ 49	TD_(2S)-U 6350-8-2
350	95		115	135	M12	13,5	20	25	100	117,5	45 ~ 67	TD_(2S)-U 6350-8-3
450	95		115	135	M12	13,5	20	25	100	117,5	57 ~ 86	TD_(2S)-U 6350-8-4
186	100		120	140	M12	13,5	35	25	105	122,5	49 ~ 74	TD_(2S)-B 6325-9-2
236	100		120	140	M12	13,5	35	25	105	122,5	59 ~ 89	TD_(2S)-B 6325-9-3
286	100		120	140	M12	13,5	35	25	105	122,5	68 ~ 102	TD_(2S)-B 6325-9-4
336	100		120	140	M12	13,5	35	25	105	122,5	77 ~ 116	TD_(2S)-B 6325-9-5
411	100		120	140	M12	13,5	35	25	105	122,5	101 ~ 151	TD_(2S)-B 6325-9-6
461	100		120	140	M12	13,5	35	25	105	122,5	110 ~ 165	TD_(2S)-B 6325-9-7
511	100		120	140	M12	13,5	35	25	105	122,5	119 ~ 179	TD_(2S)-B 6325-9-8
536	100		120	140	M12	13,5	35	25	105	122,5	118 ~ 176	TD_(2S)-B 6325-9-9
206	105	(100)	125 (120)	145 (140)	M12	13,5	20	25	110 (105)	127,5 (122,5)	42 ~ 63	TD_(2S)-U 6330-9-2
266	105	(100)	125 (120)	145 (140)	M12	13,5	20	25	110 (105)	127,5 (122,5)	53 ~ 79	TD_(2S)-U 6330-9-3
326	105	(100)	125 (120)	145 (140)	M12	13,5	20	25	110 (105)	127,5 (122,5)	64 ~ 96	TD_(2S)-U 6330-9-4
386	105	(100)	125 (120)	145 (140)	M12	13,5	20	25	110 (105)	127,5 (122,5)	75 ~ 112	TD_(2S)-U 6330-9-5
446	105	(100)	125 (120)	145 (140)	M12	13,5	20	25	110 (105)	127,5 (122,5)	86 ~ 129	TD_(2S)-U 6330-9-6
506	105	(100)	125 (120)	145 (140)	M12	13,5	20	25	110 (105)	127,5 (122,5)	99 ~ 148	TD_(2S)-U 6330-9-7
559	105	(100)	125 (120)	145 (140)	M12	13,5	20	25	110 (105)	127,5 (122,5)	105 ~ 157	TD_(2S)-U 6330-9-8
222	105	(100)	125 (120)	145 (140)	M12	13,5	20	25	110 (105)	127,5 (122,5)	41 ~ 61	TD_(2S)-U 6340-9-2
302	105	(100)	125 (120)	145 (140)	M12	13,5	20	25	110 (105)	127,5 (122,5)	54 ~ 81	TD_(2S)-U 6340-9-3
382	105	(100)	125 (120)	145 (140)	M12	13,5	20	25	110 (105)	127,5 (122,5)	67 ~ 101	TD_(2S)-U 6340-9-4
462	105	(100)	125 (120)	145 (140)	M12	13,5	20	25	110 (105)	127,5 (122,5)	81 ~ 121	TD_(2S)-U 6340-9-5
542	105	(100)	125 (120)	145 (140)	M12	13,5	20	25	110 (105)	127,5 (122,5)	92 ~ 138	TD_(2S)-U 6340-9-6
246	105	(100)	125 (120)	145 (140)	M12	13,5	20	25	110 (105)	127,5 (122,5)	43 ~ 64	TD_(2S)-U 6350-9-2
346	105	(100)	125 (120)	145 (140)	M12	13,5	20	25	110 (105)	127,5 (122,5)	59 ~ 89	TD_(2S)-U 6350-9-3
446	105	(100)	125 (120)	145 (140)	M12	13,5	20	25	110 (105)	127,5 (122,5)	75 ~ 113	TD_(2S)-U 6350-9-4
236	105		125	145	M12	13,5	25	25	110	127,5	55 ~ 83	TD_(2S)-U 6340-11-2
316	105		125	145	M12	13,5	25	25	110	127,5	71 ~ 106	TD_(2S)-U 6340-11-3
396	105		125	145	M12	13,5	25	25	110	127,5	88 ~ 132	TD_(2S)-U 6340-11-4
476	105		125	145	M12	13,5	25	25	110	127,5	105 ~ 157	TD_(2S)-U 6340-11-5
556	105		125	145	M12	13,5	25	25	110	127,5	120 ~ 180	TD_(2S)-U 6340-11-6
260	105		125	145	M12	13,5	25	25	110	127,5	57 ~ 85	TD_(2S)-U 6350-11-2
360	105		125	145	M12	13,5	25	25	110	127,5	76 ~ 114	TD_(2S)-U 6350-11-3
460	105		125	145	M12	13,5	25	25	110	127,5	97 ~ 145	TD_(2S)-U 6350-11-4
212	110		130	150	M12	13,5	40	25	115	132,5	76 ~ 113	TD_(2S)-B 6332-12-2
276	110		130	150	M12	13,5	40	25	115	132,5	90 ~ 135	TD_(2S)-B 6332-12-3
340	110		130	150	M12	13,5	40	25	115	132,5	104 ~ 156	TD_(2S)-B 6332-12-4
404	110		130	150	M12	13,5	40	25	115	132,5	121 ~ 182	TD_(2S)-B 6332-12-5

Key dimensions of the cylindrical nut: N, M, Y are obtained in the tables of page 38 of the catalogue.

SHUTON advises to use the dimensions of the tables, although it is possible to manufacture ball screw with other dimensions.

Smaller nut diameters than the first option of the table can reduce the rigidity of the assembly between 5 and 10%.

Please consult SHUTON.

COMPLEX, Double Nut (2 starts)

Ball screw reference TDB Flanged double nut TDL Cylindrical double nut TDBC Centre flanged double nut	No. Starts	Nominal diameter	Lead	Ball diameter	Root diameter	Circuits	Dynamic load capacity	Static load capacity	Rigidity of ball contact zone, with Fpr:10%Ca	Rigidity of nut, with Fpr:10%Ca
	1/2	d_0	P_h	D_w	d_2	$i (1e)$	$C_d(N)$	$C_{oa} (N)$	$R_{b/t,pr} (N/\mu m)$	$R_{nu} (N/\mu m)$
TD_(2S)-B 6332-12-6	2	63	32	12,7	54	6	451400	1130500	9420	9070
TD_(2S)-B 6332-12-7	2	63	32	12,7	54	7	518900	1335000	10930	10520
TD_(2S)-U 7025-8-2	2	70	25	7,938	63,3	2	99300	233100	3200	3020
TD_(2S)-U 7025-8-3	2	70	25	7,938	63,3	3	138900	368300	4850	4560
TD_(2S)-U 7025-8-4	2	70	25	7,938	63,3	4	177300	498800	6380	6010
TD_(2S)-U 7025-8-5	2	70	25	7,938	63,3	5	216100	634000	7970	7510
TD_(2S)-U 7025-8-6	2	70	25	7,938	63,3	6	253000	764500	9440	8900
TD_(2S)-U 7030-8-2	2	70	30	7,938	63,3	2	100300	237100	3240	3080
TD_(2S)-U 7030-8-3	2	70	30	7,938	63,3	3	138400	367300	4820	4580
TD_(2S)-U 7030-8-4	2	70	30	7,938	63,3	4	177800	502100	6400	6090
TD_(2S)-U 7030-8-5	2	70	30	7,938	63,3	5	215400	632300	7920	7540
TD_(2S)-U 7030-8-6	2	70	30	7,938	63,3	6	253200	767100	9440	8990
TD_(2S)-U 7040-8-2	2	70	40	7,938	63,3	2	99400	235500	3200	3080
TD_(2S)-U 7040-8-3	2	70	40	7,938	63,3	3	138300	369400	4810	4630
TD_(2S)-U 7040-8-4	2	70	40	7,938	63,3	4	176300	498700	6310	6080
TD_(2S)-U 7040-8-5	2	70	40	7,938	63,3	5	214500	632600	7860	7580
TD_(2S)-U 7040-8-6	2	70	40	7,938	63,3	6	252000	766600	9360	9020
TD_(2S)-U 7050-8-2	2	70	50	7,938	63,3	2	98300	233500	3140	3050
TD_(2S)-U 7050-8-3	2	70	50	7,938	63,3	3	136800	366300	4720	4580
TD_(2S)-U 7050-8-4	2	70	50	7,938	63,3	4	175400	499000	6260	6070
TD_(2S)-B 7025-9-2	2	70	25	9,525	62,2	2	126000	276500	3260	3070
TD_(2S)-B 7025-9-3	2	70	25	9,525	62,2	3	176600	438300	4910	4630
TD_(2S)-B 7025-9-4	2	70	25	9,525	62,2	4	227100	600100	6560	6180
TD_(2S)-B 7025-9-5	2	70	25	9,525	62,2	5	276600	762000	8140	7680
TD_(2S)-B 7025-9-6	2	70	25	9,525	62,2	6	313800	876600	9440	8930
TD_(2S)-B 7025-9-7	2	70	25	9,525	62,2	7	361500	1038400	11050	10450
TD_(2S)-B 7025-9-8	2	70	25	9,525	62,2	8	408200	1200200	12660	11960
TD_(2S)-B 7025-9-9	2	70	25	9,525	62,2	9	454100	1362100	14150	13370
TD_(2S)-U 7030-9-2	2	70	30	9,525	62,2	2	125600	275700	3240	3090
TD_(2S)-U 7030-9-3	2	70	30	9,525	62,2	3	176000	437100	4880	4650
TD_(2S)-U 7030-9-4	2	70	30	9,525	62,2	4	226300	598500	6520	6210
TD_(2S)-U 7030-9-5	2	70	30	9,525	62,2	5	275600	759900	8090	7710
TD_(2S)-U 7030-9-6	2	70	30	9,525	62,2	6	323800	921300	9600	9150
TD_(2S)-U 7030-9-7	2	70	30	9,525	62,2	7	371100	1082700	11050	10540
TD_(2S)-U 7030-9-8	2	70	30	9,525	62,2	8	417400	1244100	12490	11920
TD_(2S)-U 7040-9-2	2	70	40	9,525	62,2	2	126500	280600	3270	3150
TD_(2S)-U 7040-9-3	2	70	40	9,525	62,2	3	176200	440900	4880	4710
TD_(2S)-U 7040-9-4	2	70	40	9,525	62,2	4	226000	601200	6500	6260
TD_(2S)-U 7040-9-5	2	70	40	9,525	62,2	5	274900	761600	8050	7760
TD_(2S)-U 7040-9-6	2	70	40	9,525	62,2	6	322600	921900	9540	9200
TD_(2S)-U 7050-9-2	2	70	50	9,525	62,2	2	125100	278200	3210	3120

* C_d and C_{oa} : Modified static and dynamic load capacities, calculated according to DIN 69051/4 standard and ISO3408/5. See pages 39 and 43.

** $R_{b/t,pr}$: Rigidity of the balls contact zone for an external force 10% of C_d . See page 47. For a different preload force, multiply by $\sqrt[3]{F_{pr}/0,1 C_d}$

*** R_{nu} : Total rigidity of the complete nut. It must be multiplied by the factor $f_{a'}$, which depends on the manufacturing tolerance. See page 48.

Nut length 2 starts <i>TD(2S)</i>	Nut Dimensions										Grease quantity TD 'steel ball' <i>Q_{gr,real,TD}</i> (cm ³)	Ball screw reference TDB Flanged double nut TDL Cylindrical double nut TDBC Centre flanged double nut
	<i>D_{1,std}</i>	<i>D_{1,min}</i>	<i>D₄</i>	<i>D₆</i>	<i>M</i>	<i>D₅</i>	<i>L₇</i>	<i>L₁</i>	<i>L₈</i>	<i>L₉</i>		
468	110		130	150	M12	13,5	40	25	115	132,5	138 ~ 208	TD_(2S)-B 6332-12-6
532	110		130	150	M12	13,5	40	25	115	132,5	155 ~ 233	TD_(2S)-B 6332-12-7
166	105		125	145	M12	13,5	20	25	110	127,5	31 ~ 47	TD_(2S)-U 7025-8-2
216	105		125	145	M12	13,5	20	25	110	127,5	39 ~ 58	TD_(2S)-U 7025-8-3
266	105		125	145	M12	13,5	20	25	110	127,5	47 ~ 71	TD_(2S)-U 7025-8-4
316	105		125	145	M12	13,5	20	25	110	127,5	55 ~ 83	TD_(2S)-U 7025-8-5
366	105		125	145	M12	13,5	20	25	110	127,5	64 ~ 96	TD_(2S)-U 7025-8-6
184	105		125	145	M12	13,5	20	25	110	127,5	34 ~ 50	TD_(2S)-U 7030-8-2
244	105		125	145	M12	13,5	20	25	110	127,5	43 ~ 64	TD_(2S)-U 7030-8-3
304	105		125	145	M12	13,5	20	25	110	127,5	52 ~ 78	TD_(2S)-U 7030-8-4
364	105		125	145	M12	13,5	20	25	110	127,5	61 ~ 92	TD_(2S)-U 7030-8-5
424	105		125	145	M12	13,5	20	25	110	127,5	71 ~ 106	TD_(2S)-U 7030-8-6
212	105		125	145	M12	13,5	20	25	110	127,5	33 ~ 49	TD_(2S)-U 7040-8-2
292	105		125	145	M12	13,5	20	25	110	127,5	44 ~ 66	TD_(2S)-U 7040-8-3
372	105		125	145	M12	13,5	20	25	110	127,5	56 ~ 84	TD_(2S)-U 7040-8-4
452	105		125	145	M12	13,5	20	25	110	127,5	67 ~ 101	TD_(2S)-U 7040-8-5
532	105		125	145	M12	13,5	20	25	110	127,5	79 ~ 118	TD_(2S)-U 7040-8-6
252	105		125	145	M12	13,5	20	25	110	127,5	37 ~ 55	TD_(2S)-U 7050-8-2
352	105		125	145	M12	13,5	20	25	110	127,5	50 ~ 75	TD_(2S)-U 7050-8-3
452	105		125	145	M12	13,5	20	25	110	127,5	64 ~ 96	TD_(2S)-U 7050-8-4
186	110		130	150	M12	13,5	35	25	115	132,5	54 ~ 82	TD_(2S)-B 7025-9-2
236	110		130	150	M12	13,5	35	25	115	132,5	65 ~ 97	TD_(2S)-B 7025-9-3
286	110		130	150	M12	13,5	35	25	115	132,5	75 ~ 112	TD_(2S)-B 7025-9-4
336	110		130	150	M12	13,5	35	25	115	132,5	86 ~ 128	TD_(2S)-B 7025-9-5
411	110		130	150	M12	13,5	35	25	115	132,5	110 ~ 165	TD_(2S)-B 7025-9-6
461	110		130	150	M12	13,5	35	25	115	132,5	120 ~ 180	TD_(2S)-B 7025-9-7
511	110		130	150	M12	13,5	35	25	115	132,5	130 ~ 196	TD_(2S)-B 7025-9-8
533	110		130	150	M12	13,5	35	25	115	132,5	129 ~ 193	TD_(2S)-B 7025-9-9
204	110		130	150	M12	13,5	25	25	115	132,5	47 ~ 70	TD_(2S)-U 7030-9-2
264	110		130	150	M12	13,5	25	25	115	132,5	58 ~ 87	TD_(2S)-U 7030-9-3
324	110		130	150	M12	13,5	25	25	115	132,5	70 ~ 105	TD_(2S)-U 7030-9-4
384	110		130	150	M12	13,5	25	25	115	132,5	82 ~ 124	TD_(2S)-U 7030-9-5
444	110		130	150	M12	13,5	25	25	115	132,5	95 ~ 143	TD_(2S)-U 7030-9-6
504	110		130	150	M12	13,5	25	25	115	132,5	109 ~ 163	TD_(2S)-U 7030-9-7
557	110		130	150	M12	13,5	25	25	115	132,5	115 ~ 173	TD_(2S)-U 7030-9-8
220	110		130	150	M12	13,5	25	25	115	132,5	45 ~ 67	TD_(2S)-U 7040-9-2
300	110		130	150	M12	13,5	25	25	115	132,5	60 ~ 90	TD_(2S)-U 7040-9-3
380	110		130	150	M12	13,5	25	25	115	132,5	75 ~ 112	TD_(2S)-U 7040-9-4
460	110		130	150	M12	13,5	25	25	115	132,5	90 ~ 135	TD_(2S)-U 7040-9-5
540	110		130	150	M12	13,5	25	25	115	132,5	103 ~ 154	TD_(2S)-U 7040-9-6
248	110		130	150	M12	13,5	25	25	115	132,5	48 ~ 72	TD_(2S)-U 7050-9-2

Key dimensions of the cylindrical nut: N, M, Y are obtained in the tables of page 38 of the catalogue.

SHUTON advises to use the dimensions of the tables, although it is possible to manufacture ball screw with other dimensions.

Smaller nut diameters than the first option of the table can reduce the rigidity of the assembly between 5 and 10%.

Please consult SHUTON.

COMPLEX, Double Nut (2 starts)

Ball screw reference TDB Flanged double nut TDL Cylindrical double nut TDBC Centre flanged double nut	No. Starts	Nominal diameter	Lead	Ball diameter	Root diameter	Circuits	Dynamic load capacity	Static load capacity	Rigidity of ball contact zone, with Fpr:10%Ca	Rigidity of nut, with Fpr:10%Ca
	1/2	d_0	P_h	D_w	d_2	$i (1e)$	$C_d (N)$	$C_{oa} (N)$	$R_{b/t,pr} (N/\mu m)$	$R_{nu} (N/\mu m)$
TD_(2S)-U 7050-9-3	2	70	50	9,525	62,2	3	174300	437200	4800	4660
TD_(2S)-U 7050-9-4	2	70	50	9,525	62,2	4	225200	602800	6450	6260
TD_(2S)-B 7032-12-2	2	70	32	12,7	61	2	181100	363900	3330	3190
TD_(2S)-B 7032-12-3	2	70	32	12,7	61	3	258900	594400	5220	5000
TD_(2S)-B 7032-12-4	2	70	32	12,7	61	4	332700	812800	6920	6630
TD_(2S)-B 7032-12-5	2	70	32	12,7	61	5	408100	1043300	8710	8340
TD_(2S)-B 7032-12-6	2	70	32	12,7	61	6	478700	1261700	10310	9890
TD_(2S)-B 7032-12-7	2	70	32	12,7	61	7	550800	1492200	11930	11440
TD_(2S)-B 8025-9-2	2	80	25	9,525	72,2	2	137000	326000	3690	3440
TD_(2S)-B 8025-9-3	2	80	25	9,525	72,2	3	190000	509400	5530	5150
TD_(2S)-B 8025-9-4	2	80	25	9,525	72,2	4	243300	692800	7360	6860
TD_(2S)-B 8025-9-5	2	80	25	9,525	72,2	5	284800	828600	8760	8190
TD_(2S)-B 8025-9-6	2	80	25	9,525	72,2	6	337700	1018800	10630	9940
TD_(2S)-B 8025-9-7	2	80	25	9,525	72,2	7	389500	1209000	12490	11670
TD_(2S)-B 8025-9-8	2	80	25	9,525	72,2	8	437400	1385600	14200	13270
TD_(2S)-U 8030-9-2	2	80	30	9,525	72,2	2	136600	325400	3680	3480
TD_(2S)-U 8030-9-3	2	80	30	9,525	72,2	3	189500	508400	5510	5220
TD_(2S)-U 8030-9-4	2	80	30	9,525	72,2	4	242700	691400	7330	6940
TD_(2S)-U 8030-9-5	2	80	30	9,525	72,2	5	296300	881200	9100	8630
TD_(2S)-U 8030-9-6	2	80	30	9,525	72,2	6	347200	1064200	10790	10240
TD_(2S)-U 8030-9-7	2	80	30	9,525	72,2	7	397100	1247200	12430	11790
TD_(2S)-U 8040-9-2	2	80	40	9,525	72,2	2	135700	323700	3640	3490
TD_(2S)-U 8040-9-3	2	80	40	9,525	72,2	3	189900	512500	5510	5290
TD_(2S)-U 8040-9-4	2	80	40	9,525	72,2	4	242600	694600	7320	7020
TD_(2S)-U 8040-9-5	2	80	40	9,525	72,2	5	294300	876600	9000	8650
TD_(2S)-U 8040-9-6	2	80	40	9,525	72,2	6	346400	1065400	10740	10320
TD_(2S)-U 8050-9-2	2	80	50	9,525	72,2	2	136400	328300	3660	3540
TD_(2S)-U 8050-9-3	2	80	50	9,525	72,2	3	188300	509100	5440	5260
TD_(2S)-U 8050-9-4	2	80	50	9,525	72,2	4	242100	696700	7280	7050
TD_(2S)-U 8050-9-5	2	80	50	9,525	72,2	5	293300	877600	8940	8660
TD_(2S)-U 8040-11-2	2	80	40	11,113	71,1	2	167800	382200	3720	3570
TD_(2S)-U 8040-11-3	2	80	40	11,113	71,1	3	232600	596700	5530	5300
TD_(2S)-U 8040-11-4	2	80	40	11,113	71,1	4	300100	820400	7420	7110
TD_(2S)-U 8040-11-5	2	80	40	11,113	71,1	5	366000	1044200	9220	8840
TD_(2S)-U 8040-11-6	2	80	40	11,113	71,1	6	428400	1258600	10880	10440
TD_(2S)-U 8050-11-2	2	80	50	11,113	71,1	2	166400	379800	3670	3550
TD_(2S)-U 8050-11-3	2	80	50	11,113	71,1	3	233100	602100	5540	5350
TD_(2S)-U 8050-11-4	2	80	50	11,113	71,1	4	299800	824400	7390	7150
TD_(2S)-U 8050-11-5	2	80	50	11,113	71,1	5	362900	1037400	9100	8800
TD_(2S)-B 8032-12-2	2	80	32	12,7	71	2	197700	428700	3840	3650
TD_(2S)-B 8032-12-3	2	80	32	12,7	71	3	278800	685900	5820	5540

* C_a and C_{oa} : Modified static and dynamic load capacities, calculated according to DIN 69051/4 standard and ISO3408/5. See pages 39 and 43.

** $R_{b/t,pr}$: Rigidity of the balls contact zone for an external force 10% of C_a . See page 47. For a different preload force, multiply by $\sqrt[3]{F_{pr}/0,1 C_a}$

*** R_{nu} : Total rigidity of the complete nut. It must be multiplied by the factor $f_{a'}$, which depends on the manufacturing tolerance. See page 48.

Nut length 2 starts <i>TD(2S)</i>	Nut Dimensions										Grease quantity TD 'steel ball' <i>Q_{gr,real,TD}</i> (cm ³)	Ball screw reference TDB Flanged double nut TDL Cylindrical double nut TDBC Centre flanged double nut
	<i>D_{1,std}</i>	<i>D_{1,min}</i>	<i>D₄</i>	<i>D₆</i>	<i>M</i>	<i>D₅</i>	<i>L₇</i>	<i>L₁</i>	<i>L₈</i>	<i>L₉</i>		
348	110		130	150	M12	13,5	25	25	115	132,5	66 ~ 99	TD_(2S)-U 7050-9-3
448	110		130	150	M12	13,5	25	25	115	132,5	83 ~ 125	TD_(2S)-U 7050-9-4
212	120		140	160	M12	13,5	40	25	125	142,5	83 ~ 124	TD_(2S)-B 7032-12-2
276	120		140	160	M12	13,5	40	25	125	142,5	98 ~ 147	TD_(2S)-B 7032-12-3
340	120		140	160	M12	13,5	40	25	125	142,5	116 ~ 174	TD_(2S)-B 7032-12-4
404	120		140	160	M12	13,5	40	25	125	142,5	133 ~ 199	TD_(2S)-B 7032-12-5
468	120		140	160	M12	13,5	40	25	125	142,5	152 ~ 229	TD_(2S)-B 7032-12-6
532	120		140	160	M12	13,5	40	25	125	142,5	172 ~ 258	TD_(2S)-B 7032-12-7
186	120		140	160	M12	13,5	35	25	125	142,5	62 ~ 92	TD_(2S)-B 8025-9-2
236	120		140	160	M12	13,5	35	25	125	142,5	73 ~ 110	TD_(2S)-B 8025-9-3
286	120		140	160	M12	13,5	35	25	125	142,5	85 ~ 127	TD_(2S)-B 8025-9-4
361	120		140	160	M12	13,5	35	25	125	142,5	113 ~ 170	TD_(2S)-B 8025-9-5
411	120		140	160	M12	13,5	35	25	125	142,5	124 ~ 187	TD_(2S)-B 8025-9-6
461	120		140	160	M12	13,5	35	25	125	142,5	135 ~ 203	TD_(2S)-B 8025-9-7
511	120		140	160	M12	13,5	35	25	125	142,5	148 ~ 222	TD_(2S)-B 8025-9-8
202	125	(120)	145 (140)	165 (160)	M12	13,5	25	25	130 (125)	147,5 (142,5)	54 ~ 80	TD_(2S)-U 8030-9-2
262	125	(120)	145 (140)	165 (160)	M12	13,5	25	25	130 (125)	147,5 (142,5)	67 ~ 100	TD_(2S)-U 8030-9-3
322	125	(120)	145 (140)	165 (160)	M12	13,5	25	25	130 (125)	147,5 (142,5)	80 ~ 120	TD_(2S)-U 8030-9-4
382	125	(120)	145 (140)	165 (160)	M12	13,5	25	25	130 (125)	147,5 (142,5)	94 ~ 141	TD_(2S)-U 8030-9-5
442	125	(120)	145 (140)	165 (160)	M12	13,5	25	25	130 (125)	147,5 (142,5)	109 ~ 163	TD_(2S)-U 8030-9-6
502	125	(120)	145 (140)	165 (160)	M12	13,5	25	25	130 (125)	147,5 (142,5)	124 ~ 186	TD_(2S)-U 8030-9-7
218	125	(120)	145 (140)	165 (160)	M12	13,5	25	25	130 (125)	147,5 (142,5)	53 ~ 79	TD_(2S)-U 8040-9-2
298	125	(120)	145 (140)	165 (160)	M12	13,5	25	25	130 (125)	147,5 (142,5)	69 ~ 104	TD_(2S)-U 8040-9-3
378	125	(120)	145 (140)	165 (160)	M12	13,5	25	25	130 (125)	147,5 (142,5)	86 ~ 129	TD_(2S)-U 8040-9-4
458	125	(120)	145 (140)	165 (160)	M12	13,5	25	25	130 (125)	147,5 (142,5)	104 ~ 156	TD_(2S)-U 8040-9-5
538	125	(120)	145 (140)	165 (160)	M12	13,5	25	25	130 (125)	147,5 (142,5)	122 ~ 183	TD_(2S)-U 8040-9-6
252	125	(120)	145 (140)	165 (160)	M12	13,5	25	25	130 (125)	147,5 (142,5)	55 ~ 83	TD_(2S)-U 8050-9-2
352	125	(120)	145 (140)	165 (160)	M12	13,5	25	25	130 (125)	147,5 (142,5)	76 ~ 114	TD_(2S)-U 8050-9-3
452	125	(120)	145 (140)	165 (160)	M12	13,5	25	25	130 (125)	147,5 (142,5)	96 ~ 144	TD_(2S)-U 8050-9-4
552	125	(120)	145 (140)	165 (160)	M12	13,5	25	25	130 (125)	147,5 (142,5)	117 ~ 176	TD_(2S)-U 8050-9-5
249	125		145	165	M12	13,5	25	25	130	147,5	76 ~ 115	TD_(2S)-U 8040-11-2
329	125		145	165	M12	13,5	25	25	130	147,5	98 ~ 147	TD_(2S)-U 8040-11-3
409	125		145	165	M12	13,5	25	25	130	147,5	118 ~ 178	TD_(2S)-U 8040-11-4
489	125		145	165	M12	13,5	25	25	130	147,5	140 ~ 210	TD_(2S)-U 8040-11-5
569	125		145	165	M12	13,5	25	25	130	147,5	163 ~ 245	TD_(2S)-U 8040-11-6
256	125		145	165	M12	13,5	25	25	130	147,5	72 ~ 108	TD_(2S)-U 8050-11-2
356	125		145	165	M12	13,5	25	25	130	147,5	97 ~ 146	TD_(2S)-U 8050-11-3
456	125		145	165	M12	13,5	25	25	130	147,5	122 ~ 183	TD_(2S)-U 8050-11-4
556	125		145	165	M12	13,5	25	25	130	147,5	149 ~ 224	TD_(2S)-U 8050-11-5
212	130		150	170	M12	13,5	40	25	135	152,5	92 ~ 138	TD_(2S)-B 8032-12-2
276	130		150	170	M12	13,5	40	25	135	152,5	112 ~ 167	TD_(2S)-B 8032-12-3

Key dimensions of the cylindrical nut: N, M, Y are obtained in the tables of page 38 of the catalogue.

SHUTON advises to use the dimensions of the tables, although it is possible to manufacture ball screw with other dimensions.

Smaller nut diameters than the first option of the table can reduce the rigidity of the assembly between 5 and 10%.

Please consult SHUTON.

COMPLEX, Double Nut (2 starts)

Ball screw reference TDB Flanged double nut TDL Cylindrical double nut TDBC Centre flanged double nut	No. Starts	Nominal diameter	Lead	Ball diameter	Root diameter	Circuits	Dynamic load capacity	Static load capacity	Rigidity of ball contact zone, with Fpr:10%Ca	Rigidity of nut, with Fpr:10%Ca
	1/2	d_0	P_h	D_w	d_2	$i (1e)$	$C_d (N)$	$C_{oa} (N)$	$R_{b/t,pr} (N/\mu m)$	$R_{nu} (N/\mu m)$
TD_(2S)-B 8032-12-4	2	80	32	12,7	71	4	359600	943100	7800	7420
TD_(2S)-B 8032-12-5	2	80	32	12,7	71	5	438600	1200300	9760	9280
TD_(2S)-B 8032-12-6	2	80	32	12,7	71	6	515800	1457500	11640	11070
TD_(2S)-U 8040-12-2	2	80	40	12,7	71	2	200400	439100	3900	3760
TD_(2S)-U 8040-12-3	2	80	40	12,7	71	3	280600	695300	5870	5650
TD_(2S)-U 8040-12-4	2	80	40	12,7	71	4	360700	951400	7830	7540
TD_(2S)-U 8040-12-5	2	80	40	12,7	71	5	439200	1207600	9770	9410
TD_(2S)-U 8040-12-6	2	80	40	12,7	71	6	516000	1463800	11630	11200
TD_(2S)-U 8050-12-2	2	80	50	12,7	71	2	198800	436400	3850	3740
TD_(2S)-U 8050-12-3	2	80	50	12,7	71	3	278300	690900	5790	5620
TD_(2S)-U 8050-12-4	2	80	50	12,7	71	4	357800	945500	7730	7500
TD_(2S)-U 8050-12-5	2	80	50	12,7	71	5	435700	1200000	9650	9360
TD_(2S)-B 10025-9-2	2	100	25	9,525	92,2	2	154000	418400	4560	4140
TD_(2S)-B 10025-9-3	2	100	25	9,525	92,2	3	213200	651600	6760	6140
TD_(2S)-B 10025-9-4	2	100	25	9,525	92,2	4	262700	836800	8650	7880
TD_(2S)-B 10025-9-5	2	100	25	9,525	92,2	5	321500	1070100	10790	9830
TD_(2S)-B 10025-9-6	2	100	25	9,525	92,2	6	378900	1303300	13000	11850
TD_(2S)-B 10025-9-7	2	100	25	9,525	92,2	7	424600	1481600	14790	13500
TD_(2S)-U 10030-9-2	2	100	30	9,525	92,2	2	153700	417900	4550	4240
TD_(2S)-U 10030-9-3	2	100	30	9,525	92,2	3	212800	650800	6740	6290
TD_(2S)-U 10030-9-4	2	100	30	9,525	92,2	4	272200	883700	8930	8340
TD_(2S)-U 10030-9-5	2	100	30	9,525	92,2	5	329100	1109700	10990	10280
TD_(2S)-U 10040-9-2	2	100	40	9,525	92,2	2	153000	416500	4520	4290
TD_(2S)-U 10040-9-3	2	100	40	9,525	92,2	3	211900	648600	6700	6360
TD_(2S)-U 10040-9-4	2	100	40	9,525	92,2	4	271000	880700	8870	8430
TD_(2S)-U 10040-9-5	2	100	40	9,525	92,2	5	329000	1112800	10980	10440
TD_(2S)-U 10050-9-2	2	100	50	9,525	92,2	2	153800	421500	4540	4350
TD_(2S)-U 10050-9-3	2	100	50	9,525	92,2	3	212200	652600	6700	6430
TD_(2S)-U 10050-9-4	2	100	50	9,525	92,2	4	270900	883700	8850	8500
TD_(2S)-U 10050-9-5	2	100	50	9,525	92,2	5	328500	1114900	10940	10510
TD_(2S)-B 10032-12-2	2	100	32	12,7	91	2	226100	558300	4730	4440
TD_(2S)-B 10032-12-3	2	100	32	12,7	91	3	315800	880900	7220	6770
TD_(2S)-B 10032-12-4	2	100	32	12,7	91	4	405500	1203500	9550	8960
TD_(2S)-B 10032-12-5	2	100	32	12,7	91	5	474600	1439200	11510	10810
TD_(2S)-U 10040-12-2	2	100	40	12,7	91	2	225300	556800	4700	4450
TD_(2S)-U 10040-12-3	2	100	40	12,7	91	3	314700	878500	7180	6790
TD_(2S)-U 10040-12-4	2	100	40	12,7	91	4	404100	1200300	9500	8990
TD_(2S)-U 10050-12-2	2	100	50	12,7	91	2	227400	566800	4760	4550
TD_(2S)-U 10050-12-3	2	100	50	12,7	91	3	315900	887200	7210	6890
TD_(2S)-U 10050-12-4	2	100	50	12,7	91	4	404700	1207600	9510	9090
TD_(2S)-B 12025-9-2	2	120	25	9,525	112,2	2	168400	510800	5330	4700

* C_d and C_{oa} : Modified static and dynamic load capacities, calculated according to DIN 69051/4 standard and ISO3408/5. See pages 39 and 43.

** $R_{b/t,pr}$: Rigidity of the balls contact zone for an external force 10% of C_d . See page 47. For a different preload force, multiply by $\sqrt[3]{F_{pr}/0,1 C_d}$

*** R_{nu} : Total rigidity of the complete nut. It must be multiplied by the factor $f_{a,r}$, which depends on the manufacturing tolerance. See page 48.

Nut length 2 starts	Nut Dimensions										Grease quantity TD 'steel ball'	Ball screw reference
	$D_{1, std}$	$D_{1, min}$	D_4	D_6	M	D_5	L_7	L_1	L_8	L_9		
340	130		150	170	M12	13,5	40	25	135	152,5	131 ~ 196	TD_(2S)-B 8032-12-4
404	130		150	170	M12	13,5	40	25	135	152,5	150 ~ 225	TD_(2S)-B 8032-12-5
468	130		150	170	M12	13,5	40	25	135	152,5	171 ~ 256	TD_(2S)-B 8032-12-6
256	135	(130)	155 (150)	175 (170)	M12	13,5	25	25	140 (135)	157,5 (152,5)	94 ~ 141	TD_(2S)-U 8040-12-2
336	135	(130)	155 (150)	175 (170)	M12	13,5	25	25	140 (135)	157,5 (152,5)	119 ~ 178	TD_(2S)-U 8040-12-3
416	135	(130)	155 (150)	175 (170)	M12	13,5	25	25	140 (135)	157,5 (152,5)	143 ~ 214	TD_(2S)-U 8040-12-4
496	135	(130)	155 (150)	175 (170)	M12	13,5	25	25	140 (135)	157,5 (152,5)	167 ~ 251	TD_(2S)-U 8040-12-5
576	135	(130)	155 (150)	175 (170)	M12	13,5	25	25	140 (135)	157,5 (152,5)	193 ~ 289	TD_(2S)-U 8040-12-6
266	135	(130)	155 (150)	175 (170)	M12	13,5	25	25	140 (135)	157,5 (152,5)	91 ~ 137	TD_(2S)-U 8050-12-2
366	135	(130)	155 (150)	175 (170)	M12	13,5	25	25	140 (135)	157,5 (152,5)	122 ~ 183	TD_(2S)-U 8050-12-3
466	135	(130)	155 (150)	175 (170)	M12	13,5	25	25	140 (135)	157,5 (152,5)	152 ~ 229	TD_(2S)-U 8050-12-4
566	135	(130)	155 (150)	175 (170)	M12	13,5	25	25	140 (135)	157,5 (152,5)	183 ~ 274	TD_(2S)-U 8050-12-5
186	140		166	192	M16	17,5	35	25	145	168,5	75 ~ 113	TD_(2S)-B 10025-9-2
236	140		166	192	M16	17,5	35	25	145	168,5	90 ~ 135	TD_(2S)-B 10025-9-3
311	140		166	192	M16	17,5	35	25	145	168,5	123 ~ 185	TD_(2S)-B 10025-9-4
361	140		166	192	M16	17,5	35	25	145	168,5	138 ~ 207	TD_(2S)-B 10025-9-5
411	140		166	192	M16	17,5	35	25	145	168,5	152 ~ 228	TD_(2S)-B 10025-9-6
461	140		166	192	M16	17,5	35	25	145	168,5	170 ~ 255	TD_(2S)-B 10025-9-7
196	150	(140)	176 (166)	202 (192)	M16	17,5	30	25	155 (145)	178,5 (168,5)	64 ~ 96	TD_(2S)-U 10030-9-2
256	150	(140)	176 (166)	202 (192)	M16	17,5	30	25	155 (145)	178,5 (168,5)	81 ~ 121	TD_(2S)-U 10030-9-3
316	150	(140)	176 (166)	202 (192)	M16	17,5	30	25	155 (145)	178,5 (168,5)	97 ~ 146	TD_(2S)-U 10030-9-4
376	150	(140)	176 (166)	202 (192)	M16	17,5	30	25	155 (145)	178,5 (168,5)	115 ~ 173	TD_(2S)-U 10030-9-5
237	150	(140)	176 (166)	202 (192)	M16	17,5	30	25	155 (145)	178,5 (168,5)	74 ~ 111	TD_(2S)-U 10040-9-2
317	150	(140)	176 (166)	202 (192)	M16	17,5	30	25	155 (145)	178,5 (168,5)	95 ~ 142	TD_(2S)-U 10040-9-3
397	150	(140)	176 (166)	202 (192)	M16	17,5	30	25	155 (145)	178,5 (168,5)	116 ~ 174	TD_(2S)-U 10040-9-4
477	150	(140)	176 (166)	202 (192)	M16	17,5	30	25	155 (145)	178,5 (168,5)	137 ~ 206	TD_(2S)-U 10040-9-5
258	150	(140)	176 (166)	202 (192)	M16	17,5	30	25	155 (145)	178,5 (168,5)	70 ~ 105	TD_(2S)-U 10050-9-2
358	150	(140)	176 (166)	202 (192)	M16	17,5	30	25	155 (145)	178,5 (168,5)	96 ~ 143	TD_(2S)-U 10050-9-3
458	150	(140)	176 (166)	202 (192)	M16	17,5	30	25	155 (145)	178,5 (168,5)	121 ~ 181	TD_(2S)-U 10050-9-4
558	150	(140)	176 (166)	202 (192)	M16	17,5	30	25	155 (145)	178,5 (168,5)	147 ~ 220	TD_(2S)-U 10050-9-5
212	155	(150)	181 (176)	207 (202)	M16	17,5	40	25	160 (155)	183,5 (178,5)	112 ~ 169	TD_(2S)-B 10032-12-2
276	155	(150)	181 (176)	207 (202)	M16	17,5	40	25	160 (155)	183,5 (178,5)	134 ~ 201	TD_(2S)-B 10032-12-3
340	155	(150)	181 (176)	207 (202)	M16	17,5	40	25	160 (155)	183,5 (178,5)	159 ~ 238	TD_(2S)-B 10032-12-4
436	155	(150)	181 (176)	207 (202)	M16	17,5	40	25	160 (155)	183,5 (178,5)	216 ~ 324	TD_(2S)-B 10032-12-5
256	150		176	202	M16	17,5	30	25	155	178,5	118 ~ 177	TD_(2S)-U 10040-12-2
336	150		176	202	M16	17,5	30	25	155	178,5	146 ~ 219	TD_(2S)-U 10040-12-3
416	150		176	202	M16	17,5	30	25	155	178,5	177 ~ 265	TD_(2S)-U 10040-12-4
270	150		176	202	M16	17,5	30	25	155	178,5	115 ~ 173	TD_(2S)-U 10050-12-2
370	150		176	202	M16	17,5	30	25	155	178,5	151 ~ 227	TD_(2S)-U 10050-12-3
470	150		176	202	M16	17,5	30	25	155	178,5	190 ~ 284	TD_(2S)-U 10050-12-4
186	160		186	212	M16	17,5	35	25	165	188,5	89 ~ 134	TD_(2S)-B 12025-9-2

Key dimensions of the cylindrical nut: N, M, Y are obtained in the tables of page 38 of the catalogue.

SHUTON advises to use the dimensions of the tables, although it is possible to manufacture ball screw with other dimensions.

Smaller nut diameters than the first option of the table can reduce the rigidity of the assembly between 5 and 10%.

Please consult SHUTON.

COMPLEX, Double Nut (2 starts)

Ball screw reference TDB Flanged double nut TDL Cylindrical double nut TDBC Centre flanged double nut	No. Starts	Nominal diameter	Lead	Ball diameter	Root diameter	Circuits	Dynamic load capacity	Static load capacity	Rigidity of ball contact zone, with Fpr:10%Ca	Rigidity of nut, with Fpr:10%Ca
	$l/2$	d_0	P_h	D_w	d_2	$i (1e)$	$C_a(N)$	$C_{oa} (N)$	$R_{b/t,pr} (N/\mu m)$	$R_{nu} (N/\mu m)$
TD_(2S)-B 12025-9-3	2	120	25	9,525	112,2	3	231400	786900	7870	6950
TD_(2S)-B 12025-9-4	2	120	25	9,525	112,2	4	287300	1021700	10120	8970
TD_(2S)-B 12025-9-5	2	120	25	9,525	112,2	5	350000	1297800	12680	11240
TD_(2S)-B 12025-9-6	2	120	25	9,525	112,2	6	411300	1573900	15130	13420
TD_(2S)-B 12032-12-2	2	120	32	12,7	111	2	249900	688100	5650	5200
TD_(2S)-B 12032-12-3	2	120	32	12,7	111	3	347000	1075900	8470	7790
TD_(2S)-B 12032-12-4	2	120	32	12,7	111	4	444300	1463700	11220	10320
TD_(2S)-U 12040-12-2	2	120	40	12,7	111	2	249300	686800	5630	5240
TD_(2S)-U 12040-12-3	2	120	40	12,7	111	3	346100	1073900	8440	7850
TD_(2S)-U 12040-12-4	2	120	40	12,7	111	4	443300	1461000	11170	10400
TD_(2S)-U 12050-12-2	2	120	50	12,7	111	2	248400	684800	5600	5280
TD_(2S)-U 12050-12-3	2	120	50	12,7	111	3	344800	1070800	8390	7920
TD_(2S)-B 14032-12-2	2	140	32	12,7	131	2	270600	817900	6470	5830
TD_(2S)-B 14032-12-3	2	140	32	12,7	131	3	374100	1270900	9680	8720

* C_a and C_{oa} : Modified static and dynamic load capacities, calculated according to DIN 69051/4 standard and ISO3408/5. See pages 39 and 43.

** $R_{b/t,pr}$: Rigidity of the balls contact zone for an external force 10% of C_a . See page 47. For a different preload force, multiply by $\sqrt[3]{F_{pr}/0,1 C_a}$

*** R_{nu} : Total rigidity of the complete nut. It must be multiplied by the factor $f_{a,r}$, which depends on the manufacturing tolerance. See page 48.

Nut length 2 starts	Nut Dimensions										Grease quantity TD 'steel ball'	Ball screw reference TDB Flanged double nut TDL Cylindrical double nut TDBC Centre flanged double nut
	$D_{1, std}$	$D_{1, min}$	D_4	D_6	M	D_5	L_7	L_1	L_8	L_9		
236	160		186	212	M16	17,5	35	25	165	188,5	107 ~ 160	TD_(2S)-B 12025-9-3
311	160		186	212	M16	17,5	35	25	165	188,5	146 ~ 220	TD_(2S)-B 12025-9-4
361	160		186	212	M16	17,5	35	25	165	188,5	163 ~ 245	TD_(2S)-B 12025-9-5
411	160		186	212	M16	17,5	35	25	165	188,5	181 ~ 272	TD_(2S)-B 12025-9-6
212	175	(170)	201 (196)	227 (222)	M16	17,5	40	25	180 (175)	203,5 (198,5)	131 ~ 197	TD_(2S)-B 12032-12-2
276	175	(170)	201 (196)	227 (222)	M16	17,5	40	25	180 (175)	203,5 (198,5)	158 ~ 237	TD_(2S)-B 12032-12-3
340	175	(170)	201 (196)	227 (222)	M16	17,5	40	25	180 (175)	203,5 (198,5)	187 ~ 280	TD_(2S)-B 12032-12-4
256	170		196	222	M16	17,5	30	25	175	198,5	140 ~ 210	TD_(2S)-U 12040-12-2
336	170		196	222	M16	17,5	30	25	175	198,5	174 ~ 261	TD_(2S)-U 12040-12-3
416	170		196	222	M16	17,5	30	25	175	198,5	210 ~ 315	TD_(2S)-U 12040-12-4
272	170		196	222	M16	17,5	30	25	175	198,5	140 ~ 210	TD_(2S)-U 12050-12-2
372	170		196	222	M16	17,5	30	25	175	198,5	183 ~ 275	TD_(2S)-U 12050-12-3
212	195	(190)	221 (216)	247 (242)	M16	17,5	40	40	200 (195)	223,5 (218,5)	151 ~ 227	TD_(2S)-B 14032-12-2
276	195	(190)	221 (216)	247 (242)	M16	17,5	40	40	200 (195)	223,5 (218,5)	182 ~ 273	TD_(2S)-B 14032-12-3

Key dimensions of the cylindrical nut: N, M, Y are obtained in the tables of page 38 of the catalogue.

SHUTON advises to use the dimensions of the tables, although it is possible to manufacture ball screw with other dimensions.

Smaller nut diameters than the first option of the table can reduce the rigidity of the assembly between 5 and 10%.

Please consult SHUTON.

COMPLEX, Most common Ultracompact nut cases (for more possibilities, check starting from page 90)

Ball screw reference TUCB Flanged Ultracompact Nut TUCL Cylindrical Ultracompact Nut	Nominal diameter	Lead	Ball diameter	Root diameter	Circuits	Dynamic load capacity	Static load capacity	Rigidity of ball contact zone, with Fpr:10%Ca	Rigidity of nut, with Fpr:10%Ca
	d_0	P_h	D_w	d_2	$i (1e)$	$C_{a_cat} (N)$	$C_{oa_cat} (N)$	$R_{b/pr_cat} (N/\mu m)$	$R_{nut_pr_cat} (N/\mu m)$
TUC-U 4020-6-2	40	20	6,35	34,5	2	34100	57700	1070	1040
TUC-U 4020-6-3	40	20	6,35	34,5	3	47500	90600	1600	1550
TUC-U 4020-6-4	40	20	6,35	34,5	4	61400	125200	2170	2110
TUC-U 4020-6-5	40	20	6,35	34,5	5	74600	158200	2670	2600
TUC-U 4025-8-2	40	25	7,938	33,3	2	45400	72400	1130	1110
TUC-U 4025-8-3	40	25	7,938	33,3	3	64800	118100	1770	1730
TUC-U 4025-8-4	40	25	7,938	33,3	4	83100	161000	2360	2320
TUC-U 4030-8-2	40	30	7,938	33,3	2	44900	71900	1110	1090
TUC-U 4030-8-3	40	30	7,938	33,3	3	64100	117100	1740	1710
TUC-U 5020-6-2	50	20	6,35	44,5	2	38600	73600	1300	1250
TUC-U 5020-6-3	50	20	6,35	44,5	3	54200	117200	2000	1920
TUC-U 5020-6-4	50	20	6,35	44,5	4	69400	159000	2630	2530
TUC-U 5020-6-5	50	20	6,35	44,5	5	84600	202500	3280	3150
TUC-U 5020-6-6	50	20	6,35	44,5	6	99100	244400	3880	3730
TUC-U 5020-6-7	50	20	6,35	44,5	7	113800	287900	4480	4320
TUC-U 5025-8-2	50	25	7,938	43,3	2	53000	95800	1450	1410
TUC-U 5025-8-3	50	25	7,938	43,3	3	73900	150600	2160	2110
TUC-U 5025-8-4	50	25	7,938	43,3	4	95600	208100	2910	2830
TUC-U 5025-8-5	50	25	7,938	43,3	5	116800	265600	3650	3560
TUC-U 5025-8-6	50	25	7,938	43,3	6	136800	320300	4320	4210
TUC-U 5030-8-2	50	30	7,938	43,3	2	52700	95300	1430	1400
TUC-U 5030-8-3	50	30	7,938	43,3	3	74200	152500	2170	2130
TUC-U 5030-8-4	50	30	7,938	43,3	4	94900	207000	2870	2820
TUC-U 5030-8-5	50	30	7,938	43,3	5	116000	264200	3610	3530
TUC-U 6320-6-2	63	20	6,35	57,5	2	44100	96600	1640	1570
TUC-U 6320-6-3	63	20	6,35	57,5	3	61200	150800	2440	2330
TUC-U 6320-6-4	63	20	6,35	57,5	4	78400	205100	3230	3090
TUC-U 6320-6-5	63	20	6,35	57,5	5	95200	259300	4020	3840
TUC-U 6320-6-6	63	20	6,35	57,5	6	111200	311800	4740	4540
TUC-U 6325-8-2	63	25	7,938	56,3	2	60800	125100	1790	1730
TUC-U 6325-8-3	63	25	7,938	56,3	3	84900	197400	2730	2640
TUC-U 6325-8-4	63	25	7,938	56,3	4	108200	267000	3580	3460
TUC-U 6325-8-5	63	25	7,938	56,3	5	131900	339300	4460	4310
TUC-U 6325-8-6	63	25	7,938	56,3	6	155000	411600	5300	5130
TUC-U 6325-8-7	63	25	7,938	56,3	7	177700	483900	6110	5910
TUC-B 6325-9-2	63	25	9,525	55,2	2	77000	148700	1820	1770
TUC-B 6325-9-3	63	25	9,525	55,2	3	107000	233100	2720	2640
TUC-B 6325-9-4	63	25	9,525	55,2	4	138400	321500	3650	3550
TUC-B 6325-9-5	63	25	9,525	55,2	5	169000	409900	4580	4440
TUC-B 6325-9-6	63	25	9,525	55,2	6	197800	494300	5390	5240
TUC-B 6325-9-7	63	25	9,525	55,2	7	227100	582800	6240	6060
TUC-B 6325-9-8	63	25	9,525	55,2	8	254900	667200	7020	6810
TUC-U 6330-9-2	63	30	9,525	55,2	2	76700	148200	1810	1770
TUC-U 6330-9-3	63	30	9,525	55,2	3	107800	236400	2740	2680
TUC-U 6330-9-4	63	30	9,525	55,2	4	137800	320500	3630	3540
TUC-U 6330-9-5	63	30	9,525	55,2	5	168300	408600	4550	4440
TUC-B 8025-9-2	80	25	9,525	72,2	2	88300	195600	2270	2180
TUC-B 8025-9-3	80	25	9,525	72,2	3	122500	305600	3400	3260
TUC-B 8025-9-4	80	25	9,525	72,2	4	156800	415700	4520	4340
TUC-B 8025-9-5	80	25	9,525	72,2	5	190500	525700	5580	5360
TUC-B 8025-9-6	80	25	9,525	72,2	6	224400	639800	6660	6400
TUC-B 8025-9-7	80	25	9,525	72,2	7	256600	749900	7670	7380
TUC-U 8030-9-2	80	30	9,525	72,2	2	88000	195200	2260	2180
TUC-U 8030-9-3	80	30	9,525	72,2	3	122200	305000	3380	3270
TUC-U 8030-9-4	80	30	9,525	72,2	4	156400	414800	4500	4350
TUC-U 8030-9-5	80	30	9,525	72,2	5	191000	528700	5590	5410

Nut Dimensions											Grease quantity TUC 'steel ball'	Ball screw reference
$L_{n,TUC}$	$D_{1,std}$	$D_{1,min}$	D_4	D_6	M	D_5	L_7	L_1	L_8	L_9	$Q_{gr,real,TUC}$ (cm ³)	TUCB Flanged Ultracompact Nut TUCL Cylindrical Ultracompact Nut
75	65	(63)	78	93	M8	9	18	20	70	81,5	5,6 ~ 8,3	TUC_-U 4020-6-2
95	65	(63)	78	93	M8	9	18	20	70	81,5	7 ~ 11	TUC_-U 4020-6-3
115	65	(63)	78	93	M8	9	18	20	70	81,5	8,3 ~ 13	TUC_-U 4020-6-4
135	65	(63)	78	93	M8	9	18	20	70	81,5	9,9 ~ 15	TUC_-U 4020-6-5
92	70		85	100	M8	9	18	25	75	87,5	9,2 ~ 14	TUC_-U 4025-8-2
117	70		85	100	M8	9	18	25	75	87,5	11 ~ 17	TUC_-U 4025-8-3
142	70		85	100	M8	9	18	25	75	87,5	14 ~ 21	TUC_-U 4025-8-4
98	70		85	100	M8	9	18	25	75	87,5	8,8 ~ 13	TUC_-U 4030-8-2
128	70		85	100	M8	9	18	25	75	87,5	11 ~ 17	TUC_-U 4030-8-3
75	75		93	110	M10	11	18	25	85	97,5	6,9 ~ 10	TUC_-U 5020-6-2
95	75		93	110	M10	11	18	25	85	97,5	8,5 ~ 13	TUC_-U 5020-6-3
115	75		93	110	M10	11	18	25	85	97,5	10 ~ 16	TUC_-U 5020-6-4
135	75		93	110	M10	11	18	25	85	97,5	12 ~ 18	TUC_-U 5020-6-5
155	75		93	110	M10	11	18	25	85	97,5	14 ~ 21	TUC_-U 5020-6-6
175	75		93	110	M10	11	18	25	85	97,5	16 ~ 24	TUC_-U 5020-6-7
89	82		100	118	M10	11	18	25	92	105	10 ~ 15	TUC_-U 5025-8-2
114	82		100	118	M10	11	18	25	92	105	13 ~ 20	TUC_-U 5025-8-3
139	82		100	118	M10	11	18	25	92	105	16 ~ 24	TUC_-U 5025-8-4
164	82		100	118	M10	11	18	25	92	105	19 ~ 28	TUC_-U 5025-8-5
189	82		100	118	M10	11	18	25	92	105	22 ~ 33	TUC_-U 5025-8-6
95	82		100	118	M10	11	18	25	92	105	9,8 ~ 15	TUC_-U 5030-8-2
125	82		100	118	M10	11	18	25	92	105	13 ~ 20	TUC_-U 5030-8-3
155	82		100	118	M10	11	18	25	92	105	17 ~ 25	TUC_-U 5030-8-4
185	82		100	118	M10	11	18	25	92	105	20 ~ 30	TUC_-U 5030-8-5
74	95	(90)	115 (108)	135 (125)	M12 (M10)	13,5 (11)	20	25	100 (95)	117,5 (110)	8,1 ~ 12	TUC_-U 6320-6-2
94	95	(90)	115 (108)	135 (125)	M12 (M10)	13,5 (11)	20	25	100 (95)	117,5 (110)	10 ~ 16	TUC_-U 6320-6-3
114	95	(90)	115 (108)	135 (125)	M12 (M10)	13,5 (11)	20	25	100 (95)	117,5 (110)	13 ~ 19	TUC_-U 6320-6-4
134	95	(90)	115 (108)	135 (125)	M12 (M10)	13,5 (11)	20	25	100 (95)	117,5 (110)	15 ~ 22	TUC_-U 6320-6-5
154	95	(90)	115 (108)	135 (125)	M12 (M10)	13,5 (11)	20	25	100 (95)	117,5 (110)	17 ~ 26	TUC_-U 6320-6-6
89	95		115	135	M12	13,5	20	25	100	117,5	13 ~ 19	TUC_-U 6325-8-2
114	95		115	135	M12	13,5	20	25	100	117,5	16 ~ 24	TUC_-U 6325-8-3
139	95		115	135	M12	13,5	20	25	100	117,5	20 ~ 30	TUC_-U 6325-8-4
164	95		115	135	M12	13,5	20	25	100	117,5	23 ~ 35	TUC_-U 6325-8-5
189	95		115	135	M12	13,5	20	25	100	117,5	27 ~ 41	TUC_-U 6325-8-6
214	95		115	135	M12	13,5	20	25	100	117,5	31 ~ 47	TUC_-U 6325-8-7
92	105	(100)	125 (120)	145 (140)	M12	13,5	20	25	110 (105)	127,5 (122,5)	22 ~ 33	TUC_-B 6325-9-2
117	105	(100)	125 (120)	145 (140)	M12	13,5	20	25	110 (105)	127,5 (122,5)	27 ~ 40	TUC_-B 6325-9-3
142	105	(100)	125 (120)	145 (140)	M12	13,5	20	25	110 (105)	127,5 (122,5)	31 ~ 47	TUC_-B 6325-9-4
167	105	(100)	125 (120)	145 (140)	M12	13,5	20	25	110 (105)	127,5 (122,5)	36 ~ 54	TUC_-B 6325-9-5
204	105	(100)	125 (120)	145 (140)	M12	13,5	20	25	110 (105)	127,5 (122,5)	47 ~ 71	TUC_-B 6325-9-6
229	105	(100)	125 (120)	145 (140)	M12	13,5	20	25	110 (105)	127,5 (122,5)	52 ~ 78	TUC_-B 6325-9-7
254	105	(100)	125 (120)	145 (140)	M12	13,5	20	25	110 (105)	127,5 (122,5)	56 ~ 85	TUC_-B 6325-9-8
104	105	(100)	125 (120)	145 (140)	M12	13,5	20	25	110 (105)	127,5 (122,5)	18 ~ 27	TUC_-U 6330-9-2
134	105	(100)	125 (120)	145 (140)	M12	13,5	20	25	110 (105)	127,5 (122,5)	23 ~ 35	TUC_-U 6330-9-3
164	105	(100)	125 (120)	145 (140)	M12	13,5	20	25	110 (105)	127,5 (122,5)	29 ~ 43	TUC_-U 6330-9-4
194	105	(100)	125 (120)	145 (140)	M12	13,5	20	25	110 (105)	127,5 (122,5)	34 ~ 51	TUC_-U 6330-9-5
92	125	(120)	145 (140)	165 (160)	M12	13,5	25	25	130 (125)	147,5 (142,5)	27 ~ 41	TUC_-B 8025-9-2
117	125	(120)	145 (140)	165 (160)	M12	13,5	25	25	130 (125)	147,5 (142,5)	33 ~ 49	TUC_-B 8025-9-3
142	125	(120)	145 (140)	165 (160)	M12	13,5	25	25	130 (125)	147,5 (142,5)	39 ~ 58	TUC_-B 8025-9-4
179	125	(120)	145 (140)	165 (160)	M12	13,5	25	25	130 (125)	147,5 (142,5)	53 ~ 79	TUC_-B 8025-9-5
204	125	(120)	145 (140)	165 (160)	M12	13,5	25	25	130 (125)	147,5 (142,5)	58 ~ 87	TUC_-B 8025-9-6
229	125	(120)	145 (140)	165 (160)	M12	13,5	25	25	130 (125)	147,5 (142,5)	64 ~ 96	TUC_-B 8025-9-7
103	125	(120)	145 (140)	165 (160)	M12	13,5	25	25	130 (125)	147,5 (142,5)	22 ~ 33	TUC_-U 8030-9-2
133	125	(120)	145 (140)	165 (160)	M12	13,5	25	25	130 (125)	147,5 (142,5)	29 ~ 43	TUC_-U 8030-9-3
163	125	(120)	145 (140)	165 (160)	M12	13,5	25	25	130 (125)	147,5 (142,5)	35 ~ 53	TUC_-U 8030-9-4
193	125	(120)	145 (140)	165 (160)	M12	13,5	25	25	130 (125)	147,5 (142,5)	42 ~ 64	TUC_-U 8030-9-5

SHUTON
PRIME

Fine-lead high precision ball screws for precise positioning and average dynamics demand applications, such as grinding machines and EDM machines that ensure smooth rotation in short strokes.





SHUTON PRIME

S-type recirculation system

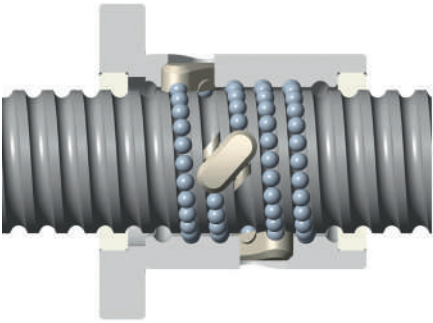

Types of PRIME nuts depending on application:

Technology	Sectors	Features	Preload	Nut type	Recirc.	Diameter	Lead	Ball size	Application
PRIME	Machine tool Grinding machines EDM machines	High precision ball screws DN of 100.000 → For precise positioning and average dynamics demand	YES	TC Compact Nut (1 start)	S	20-100	5-20	3-9	General Machine tool application, with short nut length. Improved T9
				TD Double Nut (1 start)					General Machine tool application. Possibility of greater circuit quantity

PRIME Double nut

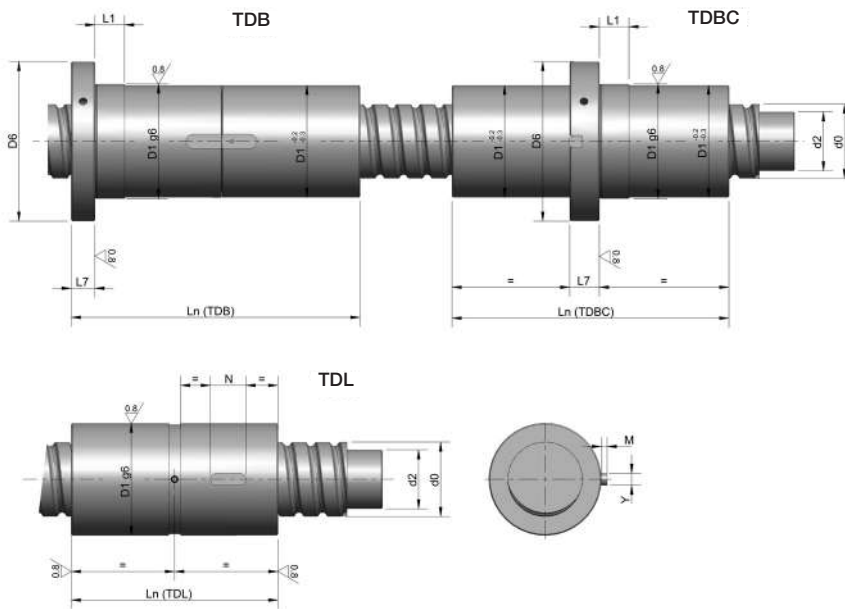

PRIME Compact nut

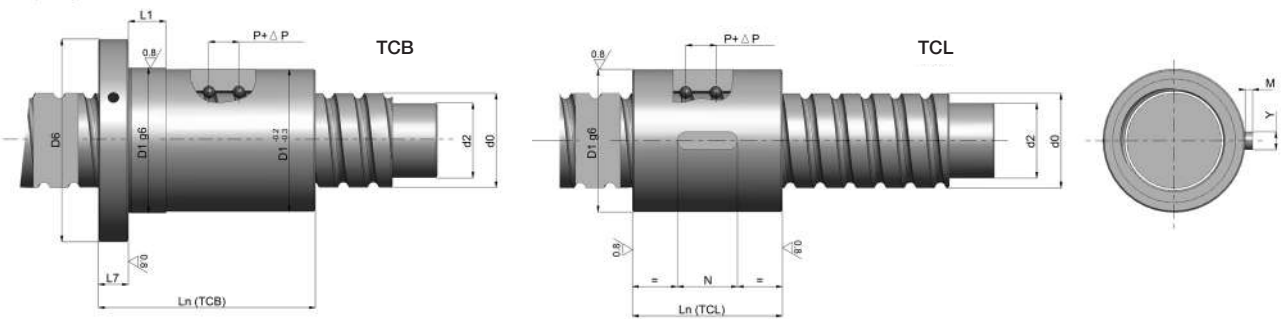

Flange design

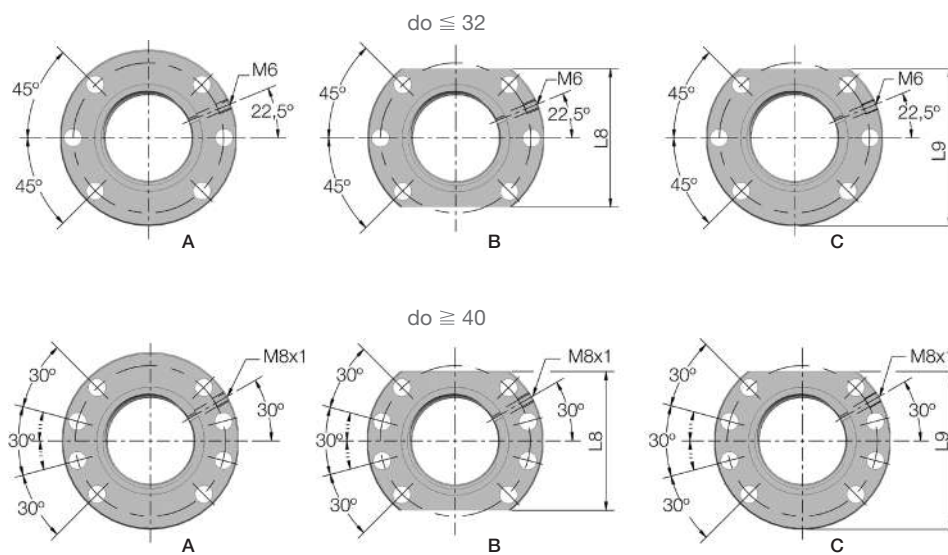

PRIME, Double Nut, Compact Nut

Ball screw reference TDB Flanged double nut TDL Cylindrical double nut TDBC Centre flanged double nut TCB Flanged compact nut TCL Cylindrical compact nut Recirculation S	Nominal diameter	Lead	Ball diameter	Root diameter	Circuits	Dynamic load capacity	Static load capacity	Rigidity of ball contact zone, with Fpr:10%Ca	Rigidity of nut, with Fpr:10%Ca	Nut length				
										d_0	P_h	D_w	d_2	$i (1e)$
TD/TC_-S 2005-3-2	20	5	3,175	17,8	2	8800	13400	460	430	66	74	62	57	52
TD/TC_-S 2005-3-3	20	5	3,175	17,8	3	12000	20400	680	650	79	85	73	68	62
TD_-S 2005-3-4	20	5	3,175	17,8	4	15300	27600	920	870	89	96	84	--	--
TD_-S 2005-3-5	20	5	3,175	17,8	5	18500	35100	1160	1110	96	107	95	--	--
TD_-S 2005-3-6	20	5	3,175	17,8	6	21800	42700	1410	1350	109	117	105	--	--
TD/TC_-S 2505-3-2	25	5	3,175	22,8	2	10000	17500	570	530	66	74	62	57	52
TD/TC_-S 2505-3-3	25	5	3,175	22,8	3	13600	26700	850	790	78	86	74	68	62
TD/TC_-S 2505-3-4	25	5	3,175	22,8	4	17300	36200	1150	1070	88	96	84	79	71
TD_-S 2505-3-5	25	5	3,175	22,8	5	21000	45900	1450	1360	98	107	95	--	--
TD_-S 2505-3-6	25	5	3,175	22,8	6	24700	55900	1770	1660	110	117	105	--	--
TD_-S 2510-5-2	25	10	4,762	21,7	2	16000	23300	470	450	97	105	92	--	--
TD_-S 2510-5-3	25	10	4,762	21,7	3	21700	34900	690	650	120	128	115	--	--
TD_-S 2510-5-4	25	10	4,762	21,7	4	27400	46500	900	850	138	152	139	--	--
TD/TC_-S 3205-3-2	32	5	3,175	29,8	2	11300	23400	720	660	73	74	67	57	52
TD/TC_-S 3205-3-3	32	5	3,175	29,8	3	15500	35600	1080	990	86	86	74	68	62
TD/TC_-S 3205-3-4	32	5	3,175	29,8	4	19700	48200	1450	1330	96	96	85	79	73
TD/TC_-S 3205-3-5	32	5	3,175	29,8	5	23900	61100	1840	1690	107	107	95	89	84
TD/TC_-S 3205-3-6	32	5	3,175	29,8	6	28100	74300	2240	2070	117	117	106	100	94
TD/TC_-S 3205-3-7	32	5	3,175	29,8	7	32200	87900	2650	2460	127	127	116	111	105
TD/TC_-S 3205-3-8	32	5	3,175	29,8	8	36100	100400	3010	2800	137	138	126	119	113
TD/TC_-S 3206-4-2	32	6	3,969	29,2	2	16100	30300	760	690	80	81	74	65	59
TD/TC_-S 3206-4-3	32	6	3,969	29,2	3	21900	46200	1130	1040	94	95	83	78	71
TD/TC_-S 3206-4-4	32	6	3,969	29,2	4	27800	62500	1510	1400	107	108	96	87	83
TD/TC_-S 3206-4-5	32	6	3,969	29,2	5	33800	79100	1920	1770	120	120	109	103	96
TD/TC_-S 3206-4-6	32	6	3,969	29,2	6	39700	96200	2330	2160	132	133	121	115	109
TD/TC_-S 3210-6-2	32	10	6,35	27,6	2	26000	39100	640	600	117	123	115	97	95
TD/TC_-S 3210-6-3	32	10	6,35	27,6	3	35300	59300	940	880	137	150	133	112	112
TD_-S 3210-6-4	32	10	6,35	27,6	4	44900	79800	1250	1180	157	172	155	--	--
TD_-S 3210-6-5	32	10	6,35	27,6	5	54500	100600	1570	1490	177	193	176	--	--
TD_-S 3210-6-6	32	10	6,35	27,6	6	63900	121900	1900	1800	205	213	196	--	--
TD/TC_-S 4005-3-2	40	5	3,175	37,8	2	12600	30000	890	790	77	74	69	59	52
TD/TC_-S 4005-3-3	40	5	3,175	37,8	3	17200	45700	1320	1190	88	86	75	70	62
TD/TC_-S 4005-3-4	40	5	3,175	37,8	4	21900	61900	1780	1610	99	97	86	81	73
TD/TC_-S 4005-3-5	40	5	3,175	37,8	5	26500	78500	2250	2050	109	107	97	91	83
TD/TC_-S 4005-3-6	40	5	3,175	37,8	6	31200	95500	2750	2510	119	114	107	103	94
TD/TC_-S 4006-4-2	40	6	3,969	37,2	2	17800	38600	920	830	83	81	75	67	59
TD/TC_-S 4006-4-3	40	6	3,969	37,2	3	24200	58800	1370	1240	97	95	84	79	71
TD/TC_-S 4006-4-4	40	6	3,969	37,2	4	30800	79500	1840	1680	110	108	97	91	83
TD/TC_-S 4006-4-5	40	6	3,969	37,2	5	37400	100700	2330	2130	122	121	110	105	96

* C_a and C_{oa} : Modified static and dynamic load capacities, calculated according to DIN 69051/4 standard and ISO3408/5. See pages 39 and 43.

** $R_{b/t,pr}$: Rigidity of the balls contact zone for an external force 10% of C_a . See page 47. For a different preload force, multiply by $\sqrt[3]{F_{pr}/0,1 C_a}$

*** R_{nu} : Total rigidity of the complete nut. It must be multiplied by the factor f_{ar} , which depends on the manufacturing tolerance. See page 48.

Nut dimensions												Grease quantity TD 'steel ball'	Grease quantity TC 'steel ball'	Ball screw reference
$D_{1, std}$	$D_{1, min}$	D_4	D_6	M	D_5	$L_{7, DB}$	$L_{7, CB}$	$L_{7, DBC}$	L_1	L_8	L_9	$Q_{gr, real, TD}$ (cm^3)	$Q_{gr, real, TC}$ (cm^3)	TDB Flanged double nut TDL Cylindrical double nut TDBC Centre flanged double nut TCB Flanged compact nut TCL Cylindrical compact nut Recirculation S
36		47	58	M6	6,6	10	12	15	10	44	51	2 ~ 3,1	1,6 ~ 2,5	TD_/TC_-S 2005-3-2
36		47	58	M6	6,6	10	12	15	10	44	51	2,4 ~ 3,7	1,9 ~ 2,9	TD_/TC_-S 2005-3-3
36		47	58	M6	6,6	10	12	15	10	44	51	2,7 ~ 4,1	--	TD_-S 2005-3-4
36		47	58	M6	6,6	10	12	15	10	44	51	2,8 ~ 4,3	--	TD_-S 2005-3-5
36		47	58	M6	6,6	10	12	15	10	44	51	3,2 ~ 4,8	--	TD_-S 2005-3-6
40		51	62	M6	6,6	10	12	15	10	48	55	2,5 ~ 3,7	2 ~ 3	TD_/TC_-S 2505-3-2
40		51	62	M6	6,6	10	12	15	10	48	55	2,8 ~ 4,2	2,4 ~ 3,6	TD_/TC_-S 2505-3-3
40		51	62	M6	6,6	10	12	15	10	48	55	3,2 ~ 4,8	2,7 ~ 4,1	TD_/TC_-S 2505-3-4
40		51	62	M6	6,6	10	12	15	10	48	55	3,4 ~ 5,2	--	TD_-S 2505-3-5
40		51	62	M6	6,6	10	12	15	10	48	55	4 ~ 6	--	TD_-S 2505-3-6
40		51	62	M6	6,6	10	12	15	16	48	55	5 ~ 7,5	--	TD_-S 2510-5-2
40		51	62	M6	6,6	10	12	15	16	48	55	6,2 ~ 9,3	--	TD_-S 2510-5-3
40		51	62	M6	6,6	10	12	15	16	48	55	7 ~ 11	--	TD_-S 2510-5-4
50		65	80	M8	9	12	12	15	10	62	71	3,6 ~ 5,4	2,5 ~ 3,8	TD_/TC_-S 3205-3-2
50		65	80	M8	9	12	12	15	10	62	71	4,2 ~ 6,3	3 ~ 4,4	TD_/TC_-S 3205-3-3
50		65	80	M8	9	12	12	15	10	62	71	4,6 ~ 6,9	3,4 ~ 5,1	TD_/TC_-S 3205-3-4
50		65	80	M8	9	12	12	15	10	62	71	5 ~ 7,6	3,8 ~ 5,7	TD_/TC_-S 3205-3-5
50		65	80	M8	9	12	12	15	10	62	71	5,4 ~ 8,1	4,2 ~ 6,4	TD_/TC_-S 3205-3-6
50		65	80	M8	9	12	12	15	10	62	71	5,8 ~ 8,7	4,7 ~ 7	TD_/TC_-S 3205-3-7
50		65	80	M8	9	12	12	15	10	62	71	6,2 ~ 9,3	4,9 ~ 7,4	TD_/TC_-S 3205-3-8
50		65	80	M8	9	12	12	15	10	62	71	5 ~ 7,6	3,7 ~ 5,6	TD_/TC_-S 3206-4-2
50		65	80	M8	9	12	12	15	10	62	71	5,8 ~ 8,7	4,4 ~ 6,6	TD_/TC_-S 3206-4-3
50		65	80	M8	9	12	12	15	10	62	71	6,5 ~ 9,7	4,7 ~ 7	TD_/TC_-S 3206-4-4
50		65	80	M8	9	12	12	15	10	62	71	7,1 ~ 11	5,6 ~ 8,4	TD_/TC_-S 3206-4-5
50		65	80	M8	9	12	12	15	10	62	71	7,7 ~ 12	6,2 ~ 9,3	TD_/TC_-S 3206-4-6
50		65	80	M8	9	14	14	20	16	62	71	12 ~ 17	8,8 ~ 13	TD_/TC_-S 3210-6-2
50		65	80	M8	9	14	14	20	16	62	71	13 ~ 20	9,9 ~ 15	TD_/TC_-S 3210-6-3
50		65	80	M8	9	14	14	20	16	62	71	15 ~ 23	--	TD_-S 3210-6-4
50		65	80	M8	9	14	14	20	16	62	71	17 ~ 25	--	TD_-S 3210-6-5
50		65	80	M8	9	14	14	20	16	62	71	20 ~ 30	--	TD_-S 3210-6-6
63		78	93	M8	9	14	14	15	10	70	81,5	4,8 ~ 7,2	3,3 ~ 4,9	TD_/TC_-S 4005-3-2
63		78	93	M8	9	14	14	15	10	70	81,5	5,4 ~ 8	3,8 ~ 5,7	TD_/TC_-S 4005-3-3
63		78	93	M8	9	14	14	15	10	70	81,5	5,9 ~ 8,9	4,4 ~ 6,5	TD_/TC_-S 4005-3-4
63		78	93	M8	9	14	14	15	10	70	81,5	6,4 ~ 9,5	4,8 ~ 7,2	TD_/TC_-S 4005-3-5
63		78	93	M8	9	14	14	15	10	70	81,5	6,7 ~ 10	5,4 ~ 8,2	TD_/TC_-S 4005-3-6
63		78	93	M8	9	14	14	15	10	70	81,5	6,5 ~ 9,8	4,8 ~ 7,2	TD_/TC_-S 4006-4-2
63		78	93	M8	9	14	14	15	10	70	81,5	7,5 ~ 11	5,5 ~ 8,2	TD_/TC_-S 4006-4-3
63		78	93	M8	9	14	14	15	10	70	81,5	8,3 ~ 12	6,2 ~ 9,3	TD_/TC_-S 4006-4-4
63		78	93	M8	9	14	14	15	10	70	81,5	9 ~ 13	7,1 ~ 11	TD_/TC_-S 4006-4-5

Key dimensions of the cylindrical nut: N, M, Y are obtained in the tables of page 38 of the catalogue.

SHUTON advises to use the dimensions of the tables, although it is possible to manufacture ball screw with other dimensions.

Smaller nut diameters than the first option of the table can reduce the rigidity of the assembly between 5 and 10%.

Please consult SHUTON.

PRIME, Double Nut, Compact Nut

Ball screw reference TDB Flanged double nut TDL Cylindrical double nut TDBC Centre flanged double nut TCB Flanged compact nut TCL Cylindrical compact nut Recirculation S	Nominal diameter	Lead	Ball diameter	Root diameter	Circuits	Dynamic load capacity	Static load capacity	Rigidity of ball contact zone, with Fpr:10%Ca	Rigidity of nut, with Fpr:10%Ca	Nut length				
										d_0	P_h	D_w	d_2	$i (1e)$
TD/TC_-S 4006-4-6	40	6	3,969	37,2	6	44000	122400	2840	2610	135	133	122	117	109
TD_-S 4008-5-2	40	8	4,762	36,7	2	22600	45200	910	830	99	99	93	--	--
TD_-S 4008-5-3	40	8	4,762	36,7	3	30800	68600	1350	1240	117	118	107	--	--
TD_-S 4008-5-4	40	8	4,762	36,7	4	39100	92700	1800	1670	134	135	124	--	--
TD_-S 4008-5-5	40	8	4,762	36,7	5	47500	117300	2280	2110	150	152	141	--	--
TD_-S 4008-5-6	40	8	4,762	36,7	6	55800	142400	2760	2570	169	169	157	--	--
TD/TC_-S 4010-6-2	40	10	6,35	35,6	2	30100	52000	810	760	119	127	116	101	96
TD/TC_-S 4010-6-3	40	10	6,35	35,6	3	40900	78800	1200	1120	139	150	134	123	115
TD/TC_-S 4010-6-4	40	10	6,35	35,6	4	52000	106000	1600	1500	164	172	160	138	131
TD/TC_-S 4010-6-5	40	10	6,35	35,6	5	63100	133700	2010	1880	184	193	177	161	153
TD_-S 4010-6-6	40	10	6,35	35,6	6	74000	161800	2420	2270	205	214	198	--	--
TD_-S 4010-6-7	40	10	6,35	35,6	7	84800	190400	2850	2680	227	234	218	--	--
TD_-S 4010-6-8	40	10	6,35	35,6	8	95000	217700	3230	3040	248	255	239	--	--
TD/TC_-S 4012-6-2	40	12	6,35	35,6	2	30100	51900	810	760	123	130	119	114	104
TD/TC_-S 4012-6-3	40	12	6,35	35,6	3	40900	78700	1200	1130	151	158	142	138	129
TD/TC_-S 4012-6-4	40	12	6,35	35,6	4	51900	105900	1590	1510	175	184	168	156	148
TD_-S 4012-6-5	40	12	6,35	35,6	5	63000	133500	2000	1900	200	210	194	--	--
TD_-S 4012-6-6	40	12	6,35	35,6	6	73900	161600	2420	2290	227	234	218	--	--
TD/TC_-S 4016-6-2	40	16	6,35	35,6	2	28600	48100	710	670	145	150	139	122	109
TD/TC_-S 4016-6-3	40	16	6,35	35,6	3	38600	72200	1020	970	180	188	172	159	151
TD_-S 4016-6-4	40	16	6,35	35,6	4	48700	96200	1340	1280	217	222	206	--	--
TD_-S 4016-6-5	40	16	6,35	35,6	5	58700	120300	1660	1580	251	256	240	--	--
TD/TC_-S 4020-6-2	40	20	6,35	35,6	2	29500	50700	740	710	160	163	152	135	131
TD_-S 4020-6-3	40	20	6,35	35,6	3	39900	76100	1070	1030	204	209	198	--	--
TD_-S 4020-6-4	40	20	6,35	35,6	4	50400	101500	1400	1350	253	256	245	--	--
TD/TC_-S 5005-3-2	50	5	3,175	47,8	2	13900	38400	1080	940	77	75	69	63	52
TD/TC_-S 5005-3-3	50	5	3,175	47,8	3	19000	58400	1610	1410	90	87	75	74	62
TD/TC_-S 5005-3-4	50	5	3,175	47,8	4	24200	79100	2170	1910	101	98	86	83	73
TD/TC_-S 5005-3-5	50	5	3,175	47,8	5	29300	100300	2740	2430	111	108	97	95	83
TD/TC_-S 5005-3-6	50	5	3,175	47,8	6	34400	122000	3340	2980	121	118	107	107	94
TD/TC_-S 5006-4-2	50	6	3,969	47,2	2	19800	49600	1130	990	86	82	76	71	59
TD/TC_-S 5006-4-3	50	6	3,969	47,2	3	26900	75500	1680	1480	100	96	90	83	71
TD/TC_-S 5006-4-4	50	6	3,969	47,2	4	34300	102100	2260	2000	112	109	98	96	84
TD/TC_-S 5006-4-5	50	6	3,969	47,2	5	41600	129400	2860	2550	124	122	110	109	96
TD/TC_-S 5006-4-6	50	6	3,969	47,2	6	48900	157300	3480	3120	136	134	123	122	109
TD_-S 5008-5-2	50	8	4,762	46,7	2	25500	58900	1130	1010	102	101	93	--	--
TD_-S 5008-5-3	50	8	4,762	46,7	3	34600	89500	1670	1500	120	119	107	--	--
TD_-S 5008-5-4	50	8	4,762	46,7	4	44100	120800	2240	2030	136	137	124	--	--
TD_-S 5008-5-5	50	8	4,762	46,7	5	53500	152900	2830	2570	152	153	141	--	--

* C_a and C_{oa} : Modified static and dynamic load capacities, calculated according to DIN 69051/4 standard and ISO3408/5. See pages 39 and 43.

** $R_{b/t,pr}$: Rigidity of the balls contact zone for an external force 10% of C_a . See page 47. For a different preload force, multiply by $\sqrt[3]{F_{pr}/0,1 C_a}$

*** R_{nu} : Total rigidity of the complete nut. It must be multiplied by the factor f_{ar} , which depends on the manufacturing tolerance. See page 48.

Nut dimensions												Grease quantity TD 'steel ball'	Grease quantity TC 'steel ball'	Ball screw reference
$D_{1, std}$	$D_{1, min}$	D_4	D_6	M	D_5	$L_{7, DB}$	$L_{7, CB}$	$L_{7, DBC}$	L_1	L_8	L_9	$Q_{gr, real, TD}$ (cm^3)	$Q_{gr, real, TC}$ (cm^3)	TDB Flanged double nut TDL Cylindrical double nut TDBC Centre flanged double nut TCB Flanged compact nut TCL Cylindrical compact nut Recirculation S
63		78	93	M8	9	14	14	15	10	70	81,5	9,8 ~ 15	7,8 ~ 12	TD_/TC_-S 4006-4-6
63		78	93	M8	9	14	14	15	10	70	81,5	8,8 ~ 13	--	TD_-S 4008-5-2
63		78	93	M8	9	14	14	15	10	70	81,5	10 ~ 15	--	TD_-S 4008-5-3
63		78	93	M8	9	14	14	15	10	70	81,5	11 ~ 17	--	TD_-S 4008-5-4
63		78	93	M8	9	14	14	15	10	70	81,5	13 ~ 19	--	TD_-S 4008-5-5
63		78	93	M8	9	14	14	15	10	70	81,5	14 ~ 21	--	TD_-S 4008-5-6
63		78	93	M8	9	14	18	20	16	70	81,5	15 ~ 22	11 ~ 17	TD_/TC_-S 4010-6-2
63		78	93	M8	9	14	18	20	16	70	81,5	17 ~ 25	14 ~ 21	TD_/TC_-S 4010-6-3
63		78	93	M8	9	14	18	20	16	70	81,5	20 ~ 29	15 ~ 22	TD_/TC_-S 4010-6-4
63		78	93	M8	9	14	18	20	16	70	81,5	22 ~ 32	18 ~ 26	TD_/TC_-S 4010-6-5
63		78	93	M8	9	14	18	20	16	70	81,5	24 ~ 36	--	TD_-S 4010-6-6
63		78	93	M8	9	14	18	20	16	70	81,5	26 ~ 39	--	TD_-S 4010-6-7
63		78	93	M8	9	14	18	20	16	70	81,5	29 ~ 43	--	TD_-S 4010-6-8
63		78	93	M8	9	14	18	20	20	70	81,5	14 ~ 21	12 ~ 19	TD_/TC_-S 4012-6-2
63		78	93	M8	9	14	18	20	20	70	81,5	17 ~ 25	15 ~ 22	TD_/TC_-S 4012-6-3
63		78	93	M8	9	14	18	20	20	70	81,5	19 ~ 29	16 ~ 24	TD_/TC_-S 4012-6-4
63		78	93	M8	9	14	18	20	20	70	81,5	22 ~ 33	--	TD_-S 4012-6-5
63		78	93	M8	9	14	18	20	20	70	81,5	25 ~ 37	--	TD_-S 4012-6-6
63		78	93	M8	9	16	18	20	20	70	81,5	15 ~ 23	12 ~ 18	TD_/TC_-S 4016-6-2
63		78	93	M8	9	16	18	20	20	70	81,5	19 ~ 29	16 ~ 24	TD_/TC_-S 4016-6-3
63		78	93	M8	9	16	18	20	20	70	81,5	23 ~ 34	--	TD_-S 4016-6-4
63		78	93	M8	9	16	18	20	20	70	81,5	26 ~ 39	--	TD_-S 4016-6-5
63		78	93	M8	9	18	18	20	20	70	81,5	16 ~ 24	12 ~ 19	TD_/TC_-S 4020-6-2
63		78	93	M8	9	18	18	20	20	70	81,5	20 ~ 30	--	TD_-S 4020-6-3
63		78	93	M8	9	18	18	20	20	70	81,5	25 ~ 38	--	TD_-S 4020-6-4
75		93	110	M10	11	16	18	16	10	85	97,5	6 ~ 8,9	4,4 ~ 6,7	TD_/TC_-S 5005-3-2
75		93	110	M10	11	16	18	16	10	85	97,5	6,8 ~ 10	5,1 ~ 7,7	TD_/TC_-S 5005-3-3
75		93	110	M10	11	16	18	16	10	85	97,5	7,5 ~ 11	5,6 ~ 8,4	TD_/TC_-S 5005-3-4
75		93	110	M10	11	16	18	16	10	85	97,5	8,1 ~ 12	6,3 ~ 9,5	TD_/TC_-S 5005-3-5
75		93	110	M10	11	16	18	16	10	85	97,5	8,6 ~ 13	7,1 ~ 11	TD_/TC_-S 5005-3-6
75		93	110	M10	11	16	18	16	10	85	97,5	8,5 ~ 13	6,4 ~ 9,7	TD_/TC_-S 5006-4-2
75		93	110	M10	11	16	18	16	10	85	97,5	9,6 ~ 14	7,3 ~ 11	TD_/TC_-S 5006-4-3
75		93	110	M10	11	16	18	16	10	85	97,5	10 ~ 16	8,3 ~ 12	TD_/TC_-S 5006-4-4
75		93	110	M10	11	16	18	16	10	85	97,5	11 ~ 17	9,2 ~ 14	TD_/TC_-S 5006-4-5
75		93	110	M10	11	16	18	16	10	85	97,5	12 ~ 18	10 ~ 15	TD_/TC_-S 5006-4-6
75		93	110	M10	11	16	18	16	10	85	97,5	11 ~ 17	--	TD_-S 5008-5-2
75		93	110	M10	11	16	18	16	10	85	97,5	13 ~ 19	--	TD_-S 5008-5-3
75		93	110	M10	11	16	18	16	10	85	97,5	14 ~ 21	--	TD_-S 5008-5-4
75		93	110	M10	11	16	18	16	10	85	97,5	16 ~ 24	--	TD_-S 5008-5-5

Key dimensions of the cylindrical nut: N, M, Y are obtained in the tables of page 38 of the catalogue.

SHUTON advises to use the dimensions of the tables, although it is possible to manufacture ball screw with other dimensions.

Smaller nut diameters than the first option of the table can reduce the rigidity of the assembly between 5 and 10%.

Please consult SHUTON.

PRIME, Double Nut, Compact Nut

Ball screw reference TDB Flanged double nut TDL Cylindrical double nut TDBC Centre flanged double nut TCB Flanged compact nut TCL Cylindrical compact nut Recirculation S	Nominal diameter	Lead	Ball diameter	Root diameter	Circuits	Dynamic load capacity	Static load capacity	Rigidity of ball contact zone, with Fpr:10%Ca	Rigidity of nut, with Fpr:10%Ca	Nut length				
										d_0	P_h	D_w	d_2	$i (1e)$
TD-S 5008-5-6	50	8	4,762	46,7	6	62800	185600	3440	3130	169	170	157	--	--
TD/TC-S 5010-6-2	50	10	6,35	44,5	2	38900	74100	1340	1240	122	127	116	101	96
TD/TC-S 5010-6-3	50	10	6,35	44,5	3	52600	111100	1940	1800	146	151	135	123	117
TD/TC-S 5010-6-4	50	10	6,35	44,5	4	66400	148200	2540	2360	167	172	155	138	131
TD/TC-S 5010-6-5	50	10	6,35	44,5	5	80000	185200	3130	2910	188	182	177	163	158
TD/TC-S 5010-6-6	50	10	6,35	44,5	6	93400	222200	3720	3470	209	214	198	185	180
TD-S 5010-6-7	50	10	6,35	44,5	7	106500	259300	4310	4020	229	234	218	--	--
TD-S 5010-6-8	50	10	6,35	44,5	8	119400	296300	4890	4560	250	255	239	--	--
TD/TC-S 5012-8-2	50	12	7,938	44,5	2	46300	83900	1020	930	136	143	132	119	113
TD/TC-S 5012-8-3	50	12	7,938	44,5	3	62900	127000	1500	1380	167	171	155	146	138
TD/TC-S 5012-8-4	50	12	7,938	44,5	4	79900	170700	1990	1840	192	197	181	165	162
TD/TC-S 5012-8-5	50	12	7,938	44,5	5	96800	215100	2500	2310	216	222	206	192	186
TD-S 5012-8-6	50	12	7,938	44,5	6	113500	260200	3010	2790	241	247	231	--	--
TD-S 5012-8-7	50	12	7,938	44,5	7	130000	305900	3530	3280	264	271	255	--	--
TD-S 5012-8-8	50	12	7,938	44,5	8	145700	349600	4010	3720	289	296	280	--	--
TD/TC-S 5015-8-2	50	15	7,938	44,5	2	46200	83800	1020	950	154	161	150	121	115
TD/TC-S 5015-8-3	50	15	7,938	44,5	3	62800	126800	1490	1400	193	196	180	159	161
TD/TC-S 5015-8-4	50	15	7,938	44,5	4	79700	170400	1990	1860	221	228	212	192	186
TD-S 5015-8-5	50	15	7,938	44,5	5	96600	214800	2490	2330	253	260	244	--	--
TD-S 5015-8-6	50	15	7,938	44,5	6	113200	259800	3000	2820	284	291	275	--	--
TD-S 5015-8-7	50	15	7,938	44,5	7	129700	305400	3520	3310	314	321	305	--	--
TD/TC-S 5016-8-2	50	16	7,938	44,5	2	46200	83800	1020	950	152	159	148	122	116
TD/TC-S 5016-8-3	50	16	7,938	44,5	3	62700	126700	1490	1400	190	196	180	172	166
TD-S 5016-8-4	50	16	7,938	44,5	4	79700	170300	1980	1870	224	231	215	--	--
TD-S 5016-8-5	50	16	7,938	44,5	5	96500	214700	2490	2340	257	264	248	--	--
TD-S 5016-8-6	50	16	7,938	44,5	6	113200	259600	3000	2830	290	297	281	--	--
TD-S 5016-8-7	50	16	7,938	44,5	7	129600	305300	3520	3320	322	329	313	--	--
TD/TC-S 5020-8-2	50	20	7,938	44,5	2	44100	78300	900	850	180	180	169	141	135
TD-S 5020-8-3	50	20	7,938	44,5	3	59600	117500	1300	1230	222	227	211	--	--
TD-S 5020-8-4	50	20	7,938	44,5	4	75300	156600	1700	1610	265	270	254	--	--
TD-S 5020-8-5	50	20	7,938	44,5	5	90800	195800	2100	1990	303	312	296	--	--
TD/TC-S 6305-3-2	63	5	3,175	60,8	2	15400	49200	1320	1100	81	77	69	64	52
TD/TC-S 6305-3-3	63	5	3,175	60,8	3	21000	74900	1970	1650	92	89	75	75	63
TD/TC-S 6305-3-4	63	5	3,175	60,8	4	26700	101400	2650	2240	103	100	86	83	73
TD/TC-S 6305-3-5	63	5	3,175	60,8	5	32400	128600	3350	2860	113	110	97	96	83
TD/TC-S 6305-3-6	63	5	3,175	60,8	6	38000	156400	4080	3510	123	121	107	107	94
TD-S 6308-5-2	63	8	4,762	59,7	2	28000	74600	1360	1180	104	103	93	--	--
TD-S 6308-5-3	63	8	4,762	59,7	3	38100	113400	2020	1770	123	122	107	--	--
TD-S 6308-5-4	63	8	4,762	59,7	4	48400	153100	2710	2380	138	139	124	--	--

* C_a and C_{oa} : Modified static and dynamic load capacities, calculated according to DIN 69051/4 standard and ISO3408/5. See pages 39 and 43.

** $R_{b/t,pr}$: Rigidity of the balls contact zone for an external force 10% of C_a . See page 47. For a different preload force, multiply by $\sqrt[3]{F_{pr}/0,1 C_a}$

*** R_{nu} : Total rigidity of the complete nut. It must be multiplied by the factor f_{ar} , which depends on the manufacturing tolerance. See page 48.

Nut dimensions												Grease quantity TD 'steel ball'	Grease quantity TC 'steel ball'	Ball screw reference
$D_{1, std}$	$D_{1, min}$	D_4	D_6	M	D_5	$L_{7, DB}$	$L_{7, CB}$	$L_{7, DBC}$	L_1	L_8	L_9	$Q_{gr, real, TD}$ (cm^3)	$Q_{gr, real, TC}$ (cm^3)	TDB Flanged double nut TDL Cylindrical double nut TDBC Centre flanged double nut TCB Flanged compact nut TCL Cylindrical compact nut Recirculation S
75		93	110	M10	11	16	18	16	10	85	97,5	17 ~ 26	--	TD_-S 5008-5-6
75		93	110	M10	11	16	18	20	16	85	97,5	16 ~ 24	12 ~ 18	TD_/TC_-S 5010-6-2
75		93	110	M10	11	16	18	20	16	85	97,5	18 ~ 28	14 ~ 21	TD_/TC_-S 5010-6-3
75		93	110	M10	11	16	18	20	16	85	97,5	21 ~ 31	15 ~ 23	TD_/TC_-S 5010-6-4
75		93	110	M10	11	16	18	20	16	85	97,5	23 ~ 34	18 ~ 27	TD_/TC_-S 5010-6-5
75		93	110	M10	11	16	18	20	16	85	97,5	25 ~ 37	20 ~ 30	TD_/TC_-S 5010-6-6
75		93	110	M10	11	16	18	20	16	85	97,5	27 ~ 40	--	TD_-S 5010-6-7
75		93	110	M10	11	16	18	20	16	85	97,5	29 ~ 43	--	TD_-S 5010-6-8
75		93	110	M10	11	16	18	20	20	85	97,5	26 ~ 38	21 ~ 31	TD_/TC_-S 5012-8-2
75		93	110	M10	11	16	18	20	20	85	97,5	31 ~ 47	26 ~ 38	TD_/TC_-S 5012-8-3
75		93	110	M10	11	16	18	20	20	85	97,5	36 ~ 54	28 ~ 42	TD_/TC_-S 5012-8-4
75		93	110	M10	11	16	18	20	20	85	97,5	40 ~ 59	33 ~ 49	TD_/TC_-S 5012-8-5
75		93	110	M10	11	16	18	20	20	85	97,5	44 ~ 66	--	TD_-S 5012-8-6
75		93	110	M10	11	16	18	20	20	85	97,5	47 ~ 71	--	TD_-S 5012-8-7
75		93	110	M10	11	16	18	20	20	85	97,5	52 ~ 77	--	TD_-S 5012-8-8
75		93	110	M10	11	16	18	20	20	85	97,5	27 ~ 41	19 ~ 28	TD_/TC_-S 5015-8-2
75		93	110	M10	11	16	18	20	20	85	97,5	34 ~ 51	26 ~ 38	TD_/TC_-S 5015-8-3
75		93	110	M10	11	16	18	20	20	85	97,5	38 ~ 58	31 ~ 47	TD_/TC_-S 5015-8-4
75		93	110	M10	11	16	18	20	20	85	97,5	44 ~ 66	--	TD_-S 5015-8-5
75		93	110	M10	11	16	18	20	20	85	97,5	49 ~ 73	--	TD_-S 5015-8-6
75		93	110	M10	11	16	18	20	20	85	97,5	53 ~ 80	--	TD_-S 5015-8-7
75		93	110	M10	11	16	18	20	20	85	97,5	26 ~ 39	18 ~ 28	TD_/TC_-S 5016-8-2
75		93	110	M10	11	16	18	20	20	85	97,5	32 ~ 48	28 ~ 42	TD_/TC_-S 5016-8-3
75		93	110	M10	11	16	18	20	20	85	97,5	38 ~ 57	--	TD_-S 5016-8-4
75		93	110	M10	11	16	18	20	20	85	97,5	43 ~ 65	--	TD_-S 5016-8-5
75		93	110	M10	11	16	18	20	20	85	97,5	48 ~ 73	--	TD_-S 5016-8-6
75		93	110	M10	11	16	18	20	20	85	97,5	53 ~ 80	--	TD_-S 5016-8-7
75		93	110	M10	11	18	20	20	20	85	97,5	30 ~ 44	21 ~ 31	TD_/TC_-S 5020-8-2
75		93	110	M10	11	18	20	20	20	85	97,5	36 ~ 54	--	TD_-S 5020-8-3
75		93	110	M10	11	18	20	20	20	85	97,5	43 ~ 65	--	TD_-S 5020-8-4
75		93	110	M10	11	18	20	20	20	85	97,5	49 ~ 73	--	TD_-S 5020-8-5
90		108	125	M10	11	18	18	18	16	95	110	8 ~ 12	5,7 ~ 8,5	TD_/TC_-S 6305-3-2
90		108	125	M10	11	18	18	18	16	95	110	8,8 ~ 13	6,5 ~ 9,8	TD_/TC_-S 6305-3-3
90		108	125	M10	11	18	18	18	16	95	110	9,6 ~ 14	6,9 ~ 10	TD_/TC_-S 6305-3-4
90		108	125	M10	11	18	18	18	16	95	110	10 ~ 15	8 ~ 12	TD_/TC_-S 6305-3-5
90		108	125	M10	11	18	18	18	16	95	110	11 ~ 16	8,8 ~ 13	TD_/TC_-S 6305-3-6
90		108	125	M10	11	18	18	18	16	95	110	14 ~ 22	--	TD_-S 6308-5-2
90		108	125	M10	11	18	18	18	16	95	110	17 ~ 25	--	TD_-S 6308-5-3
90		108	125	M10	11	18	18	18	16	95	110	18 ~ 27	--	TD_-S 6308-5-4

Key dimensions of the cylindrical nut: N, M, Y are obtained in the tables of page 38 of the catalogue.

SHUTON advises to use the dimensions of the tables, although it is possible to manufacture ball screw with other dimensions.

Smaller nut diameters than the first option of the table can reduce the rigidity of the assembly between 5 and 10%.

Please consult SHUTON.

PRIME, Double Nut, Compact Nut

Ball screw reference TDB Flanged double nut TDL Cylindrical double nut TDBC Centre flanged double nut TCB Flanged compact nut TCL Cylindrical compact nut Recirculation S	Nominal diameter	Lead	Ball diameter	Root diameter	Circuits	Dynamic load capacity	Static load capacity	Rigidity of ball contact zone, with Fpr:10%Ca	Rigidity of nut, with Fpr:10%Ca	Nut length				
										d_0	P_h	D_w	d_2	$i (1e)$
TD-S 6308-5-5	63	8	4,762	59,7	5	58700	193700	3420	3020	155	156	141	--	--
TD-S 6308-5-6	63	8	4,762	59,7	6	68900	235200	4150	3680	173	172	158	--	--
TD/TC-S 6310-6-2	63	10	6,35	57,5	2	43800	95300	1650	1490	124	127	116	108	96
TD/TC-S 6310-6-3	63	10	6,35	57,5	3	59200	142900	2380	2160	148	151	135	127	117
TD/TC-S 6310-6-4	63	10	6,35	57,5	4	74800	190500	3120	2840	169	172	155	142	131
TD/TC-S 6310-6-5	63	10	6,35	57,5	5	90100	238100	3860	3510	184	193	177	167	158
TD/TC-S 6310-6-6	63	10	6,35	57,5	6	105200	285800	4590	4180	211	214	195	189	180
TD/TC-S 6310-6-7	63	10	6,35	57,5	7	119900	333400	5310	4840	231	234	218	214	202
TD/TC-S 6310-6-8	63	10	6,35	57,5	8	134400	381000	6030	5500	252	255	239	236	224
TD/TC-S 6312-8-2	63	12	7,938	57,5	2	54300	115000	1330	1200	140	143	132	123	113
TD/TC-S 6312-8-3	63	12	7,938	57,5	3	73700	174000	1960	1770	169	171	155	150	138
TD/TC-S 6312-8-4	63	12	7,938	57,5	4	93500	233900	2600	2360	188	197	181	165	162
TD/TC-S 6312-8-5	63	12	7,938	57,5	5	113300	294700	3260	2970	219	222	206	200	187
TD/TC-S 6312-8-6	63	12	7,938	57,5	6	132800	356500	3930	3590	243	247	231	223	213
TD/TC-S 6312-8-7	63	12	7,938	57,5	7	152100	419100	4610	4220	268	271	255	249	239
TD-S 6312-8-8	63	12	7,938	57,5	8	170500	478900	5240	4790	293	296	280	--	--
TD/TC-S 6316-8-2	63	16	7,938	57,5	2	54200	114900	1330	1230	156	159	148	126	116
TD/TC-S 6316-8-3	63	16	7,938	57,5	3	73500	173800	1950	1810	194	197	181	175	166
TD/TC-S 6316-8-4	63	16	7,938	57,5	4	93400	233600	2590	2410	228	231	215	209	200
TD/TC-S 6316-8-5	63	16	7,938	57,5	5	113100	294400	3250	3030	262	265	249	242	232
TD-S 6316-8-6	63	16	7,938	57,5	6	132600	356000	3920	3660	300	298	282	--	--
TD-S 6316-8-7	63	16	7,938	57,5	7	151800	418500	4600	4300	327	330	314	--	--
TD-S 6316-8-8	63	16	7,938	57,5	8	170200	478300	5220	4880	360	363	347	--	--
TD/TC-S 6320-8-2	63	20	7,938	57,5	2	54100	114700	1320	1240	178	186	170	145	135
TD/TC-S 6320-8-3	63	20	7,938	57,5	3	73400	173500	1950	1830	225	233	212	209	198
TD/TC-S 6320-8-4	63	20	7,938	57,5	4	93200	233200	2590	2440	268	276	255	250	240
TD-S 6320-8-5	63	20	7,938	57,5	5	112800	293900	3240	3060	310	318	297	--	--
TD-S 6320-8-6	63	20	7,938	57,5	6	132300	355400	3900	3690	351	359	338	--	--
TD-S 6320-8-7	63	20	7,938	57,5	7	151500	417800	4580	4340	391	399	378	--	--
TD/TC-S 7010-6-2	70	10	6,35	64,5	2	46900	109300	1850	1670	125	128	117	109	97
TD/TC-S 7010-6-3	70	10	6,35	64,5	3	63300	163900	2670	2430	148	151	135	129	117
TD/TC-S 7010-6-4	70	10	6,35	64,5	4	80000	218600	3500	3190	170	173	157	150	138
TD/TC-S 7010-6-5	70	10	6,35	64,5	5	96400	273200	4330	3940	191	194	178	170	158
TD/TC-S 7010-6-6	70	10	6,35	64,5	6	112500	327900	5140	4690	211	214	198	192	180
TD/TC-S 7010-6-7	70	10	6,35	64,5	7	128300	382500	5960	5440	231	234	218	214	202
TD/TC-S 7010-6-8	70	10	6,35	64,5	8	143800	437100	6760	6180	252	255	239	236	224
TD/TC-S 7012-8-2	70	12	7,938	64,5	2	56100	125700	1430	1280	140	143	132	123	113
TD/TC-S 7012-8-3	70	12	7,938	64,5	3	76100	190100	2100	1890	168	171	155	148	138
TD/TC-S 7012-8-4	70	12	7,938	64,5	4	96700	255500	2790	2520	194	197	181	172	162

* C_a and C_{oa} : Modified static and dynamic load capacities, calculated according to DIN 69051/4 standard and ISO3408/5. See pages 39 and 43.

** $R_{b/t,pr}$: Rigidity of the balls contact zone for an external force 10% of C_a . See page 47. For a different preload force, multiply by $\sqrt[3]{F_{pr}/0,1 C_a}$

*** R_{nu} : Total rigidity of the complete nut. It must be multiplied by the factor f_{ar} , which depends on the manufacturing tolerance. See page 48.

Nut dimensions												Grease quantity TD 'steel ball'	Grease quantity TC 'steel ball'	Ball screw reference
$D_{1,std}$	$D_{1,min}$	D_4	D_6	M	D_5	$L_{7,DB}$	$L_{7,CB}$	$L_{7,DBC}$	L_1	L_8	L_9	$Q_{gr,real,TD}$ (cm ³)	$Q_{gr,real,TC}$ (cm ³)	TDB Flanged double nut TDL Cylindrical double nut TDBC Centre flanged double nut TCB Flanged compact nut TCL Cylindrical compact nut Recirculation S
90		108	125	M10	11	18	18	18	16	95	110	20 ~ 30	--	TD_-S 6308-5-5
90		108	125	M10	11	18	18	18	16	95	110	22 ~ 33	--	TD_-S 6308-5-6
90		108	125	M10	11	18	22	20	16	95	110	20 ~ 30	16 ~ 24	TD_/TC_-S 6310-6-2
90		108	125	M10	11	18	22	20	16	95	110	23 ~ 35	18 ~ 28	TD_/TC_-S 6310-6-3
90		108	125	M10	11	18	22	20	16	95	110	26 ~ 39	20 ~ 29	TD_/TC_-S 6310-6-4
90		108	125	M10	11	18	22	20	16	95	110	29 ~ 43	23 ~ 35	TD_/TC_-S 6310-6-5
90		108	125	M10	11	18	22	20	16	95	110	31 ~ 47	26 ~ 39	TD_/TC_-S 6310-6-6
90		108	125	M10	11	18	22	20	16	95	110	34 ~ 50	30 ~ 44	TD_/TC_-S 6310-6-7
90		108	125	M10	11	18	22	20	16	95	110	36 ~ 54	32 ~ 49	TD_/TC_-S 6310-6-8
95	(90)	115 (108)	135 (125)	M12 (M10)	13,5 (11)	20	22	20	25	100 (95)	117,5 (110)	33 ~ 49	27 ~ 40	TD_/TC_-S 6312-8-2
95	(90)	115 (108)	135 (125)	M12 (M10)	13,5 (11)	20	22	20	25	100 (95)	117,5 (110)	39 ~ 58	32 ~ 48	TD_/TC_-S 6312-8-3
95	(90)	115 (108)	135 (125)	M12 (M10)	13,5 (11)	20	22	20	25	100 (95)	117,5 (110)	44 ~ 66	34 ~ 50	TD_/TC_-S 6312-8-4
95	(90)	115 (108)	135 (125)	M12 (M10)	13,5 (11)	20	22	20	25	100 (95)	117,5 (110)	49 ~ 73	42 ~ 63	TD_/TC_-S 6312-8-5
95	(90)	115 (108)	135 (125)	M12 (M10)	13,5 (11)	20	22	20	25	100 (95)	117,5 (110)	53 ~ 80	46 ~ 69	TD_/TC_-S 6312-8-6
95	(90)	115 (108)	135 (125)	M12 (M10)	13,5 (11)	20	22	20	25	100 (95)	117,5 (110)	58 ~ 87	51 ~ 77	TD_/TC_-S 6312-8-7
95	(90)	115 (108)	135 (125)	M12 (M10)	13,5 (11)	20	22	20	25	100 (95)	117,5 (110)	63 ~ 94	--	TD_-S 6312-8-8
95	(90)	115 (108)	135 (125)	M12 (M10)	13,5 (11)	20	22	20	25	100 (95)	117,5 (110)	33 ~ 49	23 ~ 35	TD_/TC_-S 6316-8-2
95	(90)	115 (108)	135 (125)	M12 (M10)	13,5 (11)	20	22	20	25	100 (95)	117,5 (110)	40 ~ 61	35 ~ 52	TD_/TC_-S 6316-8-3
95	(90)	115 (108)	135 (125)	M12 (M10)	13,5 (11)	20	22	20	25	100 (95)	117,5 (110)	47 ~ 70	41 ~ 62	TD_/TC_-S 6316-8-4
95	(90)	115 (108)	135 (125)	M12 (M10)	13,5 (11)	20	22	20	25	100 (95)	117,5 (110)	54 ~ 80	47 ~ 71	TD_/TC_-S 6316-8-5
95	(90)	115 (108)	135 (125)	M12 (M10)	13,5 (11)	20	22	20	25	100 (95)	117,5 (110)	60 ~ 90	--	TD_-S 6316-8-6
95	(90)	115 (108)	135 (125)	M12 (M10)	13,5 (11)	20	22	20	25	100 (95)	117,5 (110)	66 ~ 99	--	TD_-S 6316-8-7
95	(90)	115 (108)	135 (125)	M12 (M10)	13,5 (11)	20	22	20	25	100 (95)	117,5 (110)	72 ~ 108	--	TD_-S 6316-8-8
95	(90)	115 (108)	135 (125)	M12 (M10)	13,5 (11)	20	22	25	25	100 (95)	117,5 (115)	35 ~ 53	26 ~ 39	TD_/TC_-S 6320-8-2
95	(90)	115 (108)	135 (125)	M12 (M10)	13,5 (11)	20	22	25	25	100 (95)	117,5 (115)	45 ~ 67	40 ~ 61	TD_/TC_-S 6320-8-3
95	(90)	115 (108)	135 (125)	M12 (M10)	13,5 (11)	20	22	25	25	100 (95)	117,5 (115)	53 ~ 80	48 ~ 72	TD_/TC_-S 6320-8-4
95	(90)	115 (108)	135 (125)	M12 (M10)	13,5 (11)	20	22	25	25	100 (95)	117,5 (115)	61 ~ 91	--	TD_-S 6320-8-5
95	(90)	115 (108)	135 (125)	M12 (M10)	13,5 (11)	20	22	25	25	100 (95)	117,5 (115)	69 ~ 103	--	TD_-S 6320-8-6
95	(90)	115 (108)	135 (125)	M12 (M10)	13,5 (11)	20	22	25	25	100 (95)	117,5 (115)	76 ~ 114	--	TD_-S 6320-8-7
105	(95)	123 (113)	140 (130)	M10	11	18	22	20	25	110 (100)	125 (115)	22 ~ 34	18 ~ 27	TD_/TC_-S 7010-6-2
105	(95)	123 (113)	140 (130)	M10	11	18	22	20	25	110 (100)	125 (115)	26 ~ 39	21 ~ 31	TD_/TC_-S 7010-6-3
105	(95)	123 (113)	140 (130)	M10	11	18	22	20	25	110 (100)	125 (115)	29 ~ 43	23 ~ 35	TD_/TC_-S 7010-6-4
105	(95)	123 (113)	140 (130)	M10	11	18	22	20	25	110 (100)	125 (115)	32 ~ 47	26 ~ 39	TD_/TC_-S 7010-6-5
105	(95)	123 (113)	140 (130)	M10	11	18	22	20	25	110 (100)	125 (115)	34 ~ 51	29 ~ 44	TD_/TC_-S 7010-6-6
105	(95)	123 (113)	140 (130)	M10	11	18	22	20	25	110 (100)	125 (115)	37 ~ 55	32 ~ 48	TD_/TC_-S 7010-6-7
105	(95)	123 (113)	140 (130)	M10	11	18	22	20	25	110 (100)	125 (115)	39 ~ 59	35 ~ 53	TD_/TC_-S 7010-6-8
105	(95)	125 (115)	145 (135)	M12	13,5	20	22	20	25	110 (100)	127,5 (117,5)	36 ~ 54	30 ~ 45	TD_/TC_-S 7012-8-2
105	(95)	125 (115)	145 (135)	M12	13,5	20	22	20	25	110 (100)	127,5 (117,5)	43 ~ 64	35 ~ 53	TD_/TC_-S 7012-8-3
105	(95)	125 (115)	145 (135)	M12	13,5	20	22	20	25	110 (100)	127,5 (117,5)	49 ~ 73	40 ~ 60	TD_/TC_-S 7012-8-4

Key dimensions of the cylindrical nut: N, M, Y are obtained in the tables of page 38 of the catalogue.

SHUTON advises to use the dimensions of the tables, although it is possible to manufacture ball screw with other dimensions.

Smaller nut diameters than the first option of the table can reduce the rigidity of the assembly between 5 and 10%.

Please consult SHUTON.

PRIME, Double Nut, Compact Nut

Ball screw reference TDB Flanged double nut TDL Cylindrical double nut TDBC Centre flanged double nut TCB Flanged compact nut TCL Cylindrical compact nut Recirculation S	Nominal diameter	Lead	Ball diameter	Root diameter	Circuits	Dynamic load capacity	Static load capacity	Rigidity of ball contact zone, with Fpr:10%Ca	Rigidity of nut, with Fpr:10%Ca	Nut length				
										d_0	P_h	D_w	d_2	$i (1e)$
TD/TC_-S 7012-8-5	70	12	7,938	64,5	5	117000	321900	3490	3170	219	222	206	197	187
TD/TC_-S 7012-8-6	70	12	7,938	64,5	6	137200	389300	4210	3830	244	247	231	223	213
TD/TC_-S 7012-8-7	70	12	7,938	64,5	7	157100	457700	4940	4500	268	271	255	249	239
TD_-S 7012-8-8	70	12	7,938	64,5	8	176100	523100	5610	5110	293	296	280	--	--
TD/TC_-S 7016-8-2	70	16	7,938	64,5	2	56000	125500	1420	1310	157	160	149	126	116
TD/TC_-S 7016-8-3	70	16	7,938	64,5	3	76000	189900	2090	1930	194	197	181	176	166
TD/TC_-S 7016-8-4	70	16	7,938	64,5	4	96500	255200	2780	2580	229	232	216	210	200
TD/TC_-S 7016-8-5	70	16	7,938	64,5	5	116900	321600	3490	3240	262	265	249	243	233
TD_-S 7016-8-6	70	16	7,938	64,5	6	137000	388900	4200	3910	295	298	282	--	--
TD_-S 7016-8-7	70	16	7,938	64,5	7	156900	457200	4930	4590	327	330	314	--	--
TD_-S 7016-8-8	70	16	7,938	64,5	8	175800	522500	5600	5220	361	364	348	--	--
TD/TC_-S 7020-8-2	70	20	7,938	64,5	2	55900	125400	1420	1330	178	181	170	145	135
TD/TC_-S 7020-8-3	70	20	7,938	64,5	3	75900	189600	2090	1960	225	228	212	208	198
TD/TC_-S 7020-8-4	70	20	7,938	64,5	4	96400	254900	2770	2610	268	271	255	250	240
TD_-S 7020-8-5	70	20	7,938	64,5	5	116700	321100	3480	3270	310	313	297	--	--
TD_-S 7020-8-6	70	20	7,938	64,5	6	136700	388400	4190	3950	352	355	339	--	--
TD_-S 7020-8-7	70	20	7,938	64,5	7	156600	456600	4920	4640	392	395	379	--	--
TD/TC_-S 8010-6-2	80	10	6,35	74,5	2	50200	126900	2090	1850	127	133	117	109	97
TD/TC_-S 8010-6-3	80	10	6,35	74,5	3	67800	190400	3030	2700	145	156	135	129	117
TD/TC_-S 8010-6-4	80	10	6,35	74,5	4	85600	253800	3960	3540	165	178	157	142	132
TD/TC_-S 8010-6-5	80	10	6,35	74,5	5	103200	317300	4890	4370	192	199	175	167	158
TD/TC_-S 8010-6-6	80	10	6,35	74,5	6	120400	380700	5820	5200	214	219	198	189	180
TD/TC_-S 8010-6-7	80	10	6,35	74,5	7	137300	444200	6730	6030	234	239	218	214	202
TD/TC_-S 8010-6-8	80	10	6,35	74,5	8	153900	507600	7650	6850	254	260	239	236	224
TD/TC_-S 8012-8-2	80	12	7,938	74,5	2	60100	146600	1620	1450	145	148	132	123	113
TD/TC_-S 8012-8-3	80	12	7,938	74,5	3	81500	221700	2380	2140	171	176	155	150	138
TD/TC_-S 8012-8-4	80	12	7,938	74,5	4	103500	298000	3160	2860	193	202	181	169	162
TD/TC_-S 8012-8-5	80	12	7,938	74,5	5	125300	375500	3960	3590	221	228	207	197	187
TD/TC_-S 8012-8-6	80	12	7,938	74,5	6	146800	454100	4780	4340	245	252	231	223	213
TD/TC_-S 8012-8-7	80	12	7,938	74,5	7	168100	533800	5610	5100	273	276	255	250	240
TD_-S 8012-8-8	80	12	7,938	74,5	8	188400	610000	6360	5800	298	299	280	--	--
TD/TC_-S 8016-8-2	80	16	7,938	74,5	2	60000	146500	1620	1490	161	164	148	126	116
TD/TC_-S 8016-8-3	80	16	7,938	74,5	3	81400	221500	2380	2190	196	202	181	175	166
TD/TC_-S 8016-8-4	80	16	7,938	74,5	4	103300	297800	3160	2920	237	236	215	209	200
TD/TC_-S 8016-8-5	80	16	7,938	74,5	5	125100	375200	3950	3670	270	270	249	242	232
TD_-S 8016-8-6	80	16	7,938	74,5	6	146700	453700	4770	4430	300	303	282	--	--
TD_-S 8016-8-7	80	16	7,938	74,5	7	167900	533300	5600	5210	334	335	314	--	--
TD_-S 8016-8-8	80	16	7,938	74,5	8	188200	609500	6350	5920	365	368	347	--	--
TD/TC_-S 8020-9-2	80	20	9,525	73,3	2	76500	172800	1620	1510	187	192	175	148	140

* C_a and C_{oa} : Modified static and dynamic load capacities, calculated according to DIN 69051/4 standard and ISO3408/5. See pages 39 and 43.

** $R_{b/t,pr}$: Rigidity of the balls contact zone for an external force 10% of C_a . See page 47. For a different preload force, multiply by $\sqrt[3]{F_{pr}/0,1 C_a}$

*** R_{nu} : Total rigidity of the complete nut. It must be multiplied by the factor f_{ar} , which depends on the manufacturing tolerance. See page 48.

Nut dimensions												Grease quantity TD 'steel ball'	Grease quantity TC 'steel ball'	Ball screw reference
$D_{1, std}$	$D_{1, min}$	D_4	D_6	M	D_5	$L_{7, DB}$	$L_{7, CB}$	$L_{7, DBC}$	L_1	L_8	L_9	$Q_{gr, real, TD}$ (cm^3)	$Q_{gr, real, TC}$ (cm^3)	TDB Flanged double nut TDL Cylindrical double nut TDBC Centre flanged double nut TCB Flanged compact nut TCL Cylindrical compact nut Recirculation S
105	(95)	125 (115)	145 (135)	M12	13,5	20	22	20	25	110 (100)	127,5 (117,5)	54 ~ 81	46 ~ 68	TD_/TC_-S 7012-8-5
105	(95)	125 (115)	145 (135)	M12	13,5	20	22	20	25	110 (100)	127,5 (117,5)	59 ~ 89	51 ~ 77	TD_/TC_-S 7012-8-6
105	(95)	125 (115)	145 (135)	M12	13,5	20	22	20	25	110 (100)	127,5 (117,5)	65 ~ 97	57 ~ 86	TD_/TC_-S 7012-8-7
105	(95)	125 (115)	145 (135)	M12	13,5	20	22	20	25	110 (100)	127,5 (117,5)	70 ~ 105	--	TD_-S 7012-8-8
105	(95)	125 (115)	145 (135)	M12	13,5	20	22	20	25	110 (100)	127,5 (117,5)	37 ~ 55	26 ~ 39	TD_/TC_-S 7016-8-2
105	(95)	125 (115)	145 (135)	M12	13,5	20	22	20	25	110 (100)	127,5 (117,5)	45 ~ 67	39 ~ 58	TD_/TC_-S 7016-8-3
105	(95)	125 (115)	145 (135)	M12	13,5	20	22	20	25	110 (100)	127,5 (117,5)	53 ~ 79	46 ~ 69	TD_/TC_-S 7016-8-4
105	(95)	125 (115)	145 (135)	M12	13,5	20	22	20	25	110 (100)	127,5 (117,5)	60 ~ 89	53 ~ 80	TD_/TC_-S 7016-8-5
105	(95)	125 (115)	145 (135)	M12	13,5	20	22	20	25	110 (100)	127,5 (117,5)	66 ~ 100	--	TD_-S 7016-8-6
105	(95)	125 (115)	145 (135)	M12	13,5	20	22	20	25	110 (100)	127,5 (117,5)	73 ~ 110	--	TD_-S 7016-8-7
105	(95)	125 (115)	145 (135)	M12	13,5	20	22	20	25	110 (100)	127,5 (117,5)	80 ~ 121	--	TD_-S 7016-8-8
105	(95)	125 (115)	145 (135)	M12	13,5	20	22	20	25	110 (100)	127,5 (117,5)	39 ~ 59	29 ~ 44	TD_/TC_-S 7020-8-2
105	(95)	125 (115)	145 (135)	M12	13,5	20	22	20	25	110 (100)	127,5 (117,5)	50 ~ 75	44 ~ 67	TD_/TC_-S 7020-8-3
105	(95)	125 (115)	145 (135)	M12	13,5	20	22	20	25	110 (100)	127,5 (117,5)	59 ~ 88	53 ~ 80	TD_/TC_-S 7020-8-4
105	(95)	125 (115)	145 (135)	M12	13,5	20	22	20	25	110 (100)	127,5 (117,5)	68 ~ 102	--	TD_-S 7020-8-5
105	(95)	125 (115)	145 (135)	M12	13,5	20	22	20	25	110 (100)	127,5 (117,5)	77 ~ 115	--	TD_-S 7020-8-6
105	(95)	125 (115)	145 (135)	M12	13,5	20	22	20	25	110 (100)	127,5 (117,5)	85 ~ 127	--	TD_-S 7020-8-7
115	(105)	135 (125)	155 (145)	M12	13,5	20	22	25	16	120 (110)	137,5 (127,5)	26 ~ 39	21 ~ 31	TD_/TC_-S 8010-6-2
115	(105)	135 (125)	155 (145)	M12	13,5	20	22	25	16	120 (110)	137,5 (127,5)	28 ~ 42	23 ~ 35	TD_/TC_-S 8010-6-3
115	(105)	135 (125)	155 (145)	M12	13,5	20	22	25	16	120 (110)	137,5 (127,5)	31 ~ 47	24 ~ 36	TD_/TC_-S 8010-6-4
115	(105)	135 (125)	155 (145)	M12	13,5	20	22	25	16	120 (110)	137,5 (127,5)	36 ~ 54	28 ~ 43	TD_/TC_-S 8010-6-5
115	(105)	135 (125)	155 (145)	M12	13,5	20	22	25	16	120 (110)	137,5 (127,5)	39 ~ 59	32 ~ 48	TD_/TC_-S 8010-6-6
115	(105)	135 (125)	155 (145)	M12	13,5	20	22	25	16	120 (110)	137,5 (127,5)	42 ~ 63	36 ~ 54	TD_/TC_-S 8010-6-7
115	(105)	135 (125)	155 (145)	M12	13,5	20	22	25	16	120 (110)	137,5 (127,5)	45 ~ 68	40 ~ 60	TD_/TC_-S 8010-6-8
125	(105)	145 (125)	165 (145)	M12	13,5	25	22	25	25	130 (110)	147,5 (127,5)	43 ~ 65	34 ~ 50	TD_/TC_-S 8012-8-2
125	(105)	145 (125)	165 (145)	M12	13,5	25	22	25	25	130 (110)	147,5 (127,5)	51 ~ 76	40 ~ 61	TD_/TC_-S 8012-8-3
125	(105)	145 (125)	165 (145)	M12	13,5	25	22	25	25	130 (110)	147,5 (127,5)	57 ~ 86	44 ~ 66	TD_/TC_-S 8012-8-4
125	(105)	145 (125)	165 (145)	M12	13,5	25	22	25	25	130 (110)	147,5 (127,5)	64 ~ 95	51 ~ 77	TD_/TC_-S 8012-8-5
125	(105)	145 (125)	165 (145)	M12	13,5	25	22	25	25	130 (110)	147,5 (127,5)	69 ~ 104	58 ~ 87	TD_/TC_-S 8012-8-6
125	(105)	145 (125)	165 (145)	M12	13,5	25	22	25	25	130 (110)	147,5 (127,5)	75 ~ 112	65 ~ 97	TD_/TC_-S 8012-8-7
125	(105)	145 (125)	165 (145)	M12	13,5	25	22	25	25	130 (110)	147,5 (127,5)	81 ~ 121	--	TD_-S 8012-8-8
125	(105)	145 (125)	165 (145)	M12	13,5	25	22	25	25	130 (110)	147,5 (127,5)	43 ~ 64	29 ~ 44	TD_/TC_-S 8016-8-2
125	(105)	145 (125)	165 (145)	M12	13,5	25	22	25	25	130 (110)	147,5 (127,5)	53 ~ 79	43 ~ 65	TD_/TC_-S 8016-8-3
125	(105)	145 (125)	165 (145)	M12	13,5	25	22	25	25	130 (110)	147,5 (127,5)	61 ~ 91	52 ~ 77	TD_/TC_-S 8016-8-4
125	(105)	145 (125)	165 (145)	M12	13,5	25	22	25	25	130 (110)	147,5 (127,5)	69 ~ 103	59 ~ 89	TD_/TC_-S 8016-8-5
125	(105)	145 (125)	165 (145)	M12	13,5	25	22	25	25	130 (110)	147,5 (127,5)	77 ~ 115	--	TD_-S 8016-8-6
125	(105)	145 (125)	165 (145)	M12	13,5	25	22	25	25	130 (110)	147,5 (127,5)	85 ~ 127	--	TD_-S 8016-8-7
125	(105)	145 (125)	165 (145)	M12	13,5	25	22	25	25	130 (110)	147,5 (127,5)	92 ~ 138	--	TD_-S 8016-8-8
125	(110)	145 (130)	165 (150)	M12	13,5	25	22	25	25	130 (115)	147,5 (132,5)	59 ~ 88	41 ~ 61	TD_/TC_-S 8020-9-2

Key dimensions of the cylindrical nut: N, M, Y are obtained in the tables of page 38 of the catalogue.

SHUTON advises to use the dimensions of the tables, although it is possible to manufacture ball screw with other dimensions.

Smaller nut diameters than the first option of the table can reduce the rigidity of the assembly between 5 and 10%.

Please consult SHUTON.

PRIME, Double Nut, Compact Nut

Ball screw reference TDB Flanged double nut TDL Cylindrical double nut TDBC Centre flanged double nut TCB Flanged compact nut TCL Cylindrical compact nut Recirculation S	Nominal diameter	Lead	Ball diameter	Root diameter	Circuits	Dynamic load capacity	Static load capacity	Rigidity of ball contact zone, with Fpr:10%Ca	Rigidity of nut, with Fpr:10%Ca	Nut length				
										d_0	P_h	D_w	d_2	$i (1e)$
TD/TC_-S 8020-9-3	80	20	9,525	73,3	3	103700	261100	2370	2220	233	239	217	211	202
TD/TC_-S 8020-9-4	80	20	9,525	73,3	4	131600	350500	3150	2950	277	282	260	253	245
TD_-S 8020-9-5	80	20	9,525	73,3	5	159300	441200	3940	3690	319	324	302	--	--
TD_-S 8020-9-6	80	20	9,525	73,3	6	186600	533000	4740	4450	360	366	344	--	--
TD_-S 8020-9-7	80	20	9,525	73,3	7	213600	626000	5550	5220	400	406	384	--	--
TD_-S 8020-9-8	80	20	9,525	73,3	8	239400	715400	6300	5930	442	447	425	--	--
TD/TC_-S 10010-6-2	100	10	6,35	94,5	2	55100	158700	2500	2130	129	133	117	109	97
TD/TC_-S 10010-6-3	100	10	6,35	94,5	3	74400	238100	3620	3100	152	156	135	130	118
TD/TC_-S 10010-6-4	100	10	6,35	94,5	4	94000	317400	4740	4070	167	178	157	142	132
TD/TC_-S 10010-6-5	100	10	6,35	94,5	5	113300	396800	5860	5040	195	199	178	167	158
TD/TC_-S 10010-6-6	100	10	6,35	94,5	6	132200	476200	6970	6000	216	220	204	189	180
TD/TC_-S 10010-6-7	100	10	6,35	94,5	7	150700	555500	8060	6950	236	240	219	214	202
TD/TC_-S 10010-6-8	100	10	6,35	94,5	8	169000	634900	9160	7900	257	260	239	236	224
TD/TC_-S 10012-8-2	100	12	7,938	94,5	2	66800	188500	1980	1730	151	154	133	131	113
TD/TC_-S 10012-8-3	100	12	7,938	94,5	3	90700	285000	2920	2560	179	182	156	156	138
TD/TC_-S 10012-8-4	100	12	7,938	94,5	4	115100	383100	3880	3410	198	200	182	181	163
TD/TC_-S 10012-8-5	100	12	7,938	94,5	5	139400	482600	4860	4290	223	233	207	205	187
TD/TC_-S 10012-8-6	100	12	7,938	94,5	6	163300	583600	5860	5180	247	258	232	231	213
TD/TC_-S 10012-8-7	100	12	7,938	94,5	7	187000	686100	6870	6100	279	282	256	258	240
TD_-S 10012-8-8	100	12	7,938	94,5	8	209600	784100	7800	6930	304	298	281	--	--
TD/TC_-S 10016-8-2	100	16	7,938	94,5	2	66800	188400	1980	1780	166	169	148	134	116
TD/TC_-S 10016-8-3	100	16	7,938	94,5	3	90600	284900	2910	2630	204	207	181	184	166
TD/TC_-S 10016-8-4	100	16	7,938	94,5	4	115000	382900	3870	3510	243	241	215	218	200
TD/TC_-S 10016-8-5	100	16	7,938	94,5	5	139300	482400	4850	4410	272	275	249	250	232
TD_-S 10016-8-6	100	16	7,938	94,5	6	163200	583300	5850	5330	304	308	282	--	--
TD_-S 10016-8-7	100	16	7,938	94,5	7	186900	685700	6860	6270	337	340	314	--	--
TD_-S 10016-8-8	100	16	7,938	94,5	8	209400	783600	7790	7120	370	373	347	--	--
TD/TC_-S 10020-9-2	100	20	9,525	93,3	2	86200	225400	2010	1840	192	198	176	157	140
TD/TC_-S 10020-9-3	100	20	9,525	93,3	3	116900	340500	2950	2710	239	245	218	219	203
TD/TC_-S 10020-9-4	100	20	9,525	93,3	4	148400	457200	3920	3600	282	288	261	262	245
TD_-S 10020-9-5	100	20	9,525	93,3	5	179500	575400	4900	4510	324	330	303	--	--
TD_-S 10020-9-6	100	20	9,525	93,3	6	210300	695100	5900	5440	366	371	344	--	--
TD_-S 10020-9-7	100	20	9,525	93,3	7	240700	816300	6910	6380	406	411	384	--	--
TD_-S 10020-9-8	100	20	9,525	93,3	8	269700	932900	7840	7250	447	453	426	--	--

* C_a and C_{oa} : Modified static and dynamic load capacities, calculated according to DIN 69051/4 standard and ISO3408/5. See pages 39 and 43.

** $R_{b/t,pr}$: Rigidity of the balls contact zone for an external force 10% of C_a . See page 47. For a different preload force, multiply by $\sqrt[3]{F_{pr}/0,1 C_a}$

*** R_{nu} : Total rigidity of the complete nut. It must be multiplied by the factor f_{ar} , which depends on the manufacturing tolerance. See page 48.

Nut dimensions												Grease quantity TD 'steel ball'	Grease quantity TC 'steel ball'	Ball screw reference
$D_{1,std}$	$D_{1,min}$	D_4	D_6	M	D_5	$L_{7,DB}$	$L_{7,CB}$	$L_{7,DBC}$	L_1	L_8	L_9	$Q_{gr,real,TD}$ (cm ³)	$Q_{gr,real,TC}$ (cm ³)	TDB Flanged double nut TDL Cylindrical double nut TDBC Centre flanged double nut TCB Flanged compact nut TCL Cylindrical compact nut Recirculation S
125	(110)	145 (130)	165 (150)	M12	13,5	25	22	25	25	130 (115)	147,5 (132,5)	73 ~ 109	63 ~ 94	TD_/TC_-S 8020-9-3
125	(110)	145 (130)	165 (150)	M12	13,5	25	22	25	25	130 (115)	147,5 (132,5)	86 ~ 129	75 ~ 112	TD_/TC_-S 8020-9-4
125	(110)	145 (130)	165 (150)	M12	13,5	25	22	25	25	130 (115)	147,5 (132,5)	98 ~ 147	--	TD_-S 8020-9-5
125	(110)	145 (130)	165 (150)	M12	13,5	25	22	25	25	130 (115)	147,5 (132,5)	110 ~ 164	--	TD_-S 8020-9-6
125	(110)	145 (130)	165 (150)	M12	13,5	25	22	25	25	130 (115)	147,5 (132,5)	121 ~ 181	--	TD_-S 8020-9-7
125	(110)	145 (130)	165 (150)	M12	13,5	25	22	25	25	130 (115)	147,5 (132,5)	133 ~ 200	--	TD_-S 8020-9-8
135	(125)	155 (145)	175 (165)	M12	13,5	22	22	25	16	140 (130)	157,5 (147,5)	33 ~ 50	26 ~ 38	TD_/TC_-S 10010-6-2
135	(125)	155 (145)	175 (165)	M12	13,5	22	22	25	16	140 (130)	157,5 (147,5)	38 ~ 57	29 ~ 44	TD_/TC_-S 10010-6-3
135	(125)	155 (145)	175 (165)	M12	13,5	22	22	25	16	140 (130)	157,5 (147,5)	39 ~ 59	30 ~ 45	TD_/TC_-S 10010-6-4
135	(125)	155 (145)	175 (165)	M12	13,5	22	22	25	16	140 (130)	157,5 (147,5)	46 ~ 69	35 ~ 53	TD_/TC_-S 10010-6-5
135	(125)	155 (145)	175 (165)	M12	13,5	22	22	25	16	140 (130)	157,5 (147,5)	50 ~ 75	40 ~ 60	TD_/TC_-S 10010-6-6
135	(125)	155 (145)	175 (165)	M12	13,5	22	22	25	16	140 (130)	157,5 (147,5)	53 ~ 80	45 ~ 68	TD_/TC_-S 10010-6-7
135	(125)	155 (145)	175 (165)	M12	13,5	22	22	25	16	140 (130)	157,5 (147,5)	57 ~ 86	49 ~ 74	TD_/TC_-S 10010-6-8
150	(125)	176 (145)	202 (165)	M16 (M12)	17,5 (13,5)	30	--	30	25	155 (130)	178,5 (147,5)	56 ~ 85	46 ~ 68	TD_/TC_-S 10012-8-2
150	(125)	176 (145)	202 (165)	M16 (M12)	17,5 (13,5)	30	--	30	25	155 (130)	178,5 (147,5)	65 ~ 98	53 ~ 79	TD_/TC_-S 10012-8-3
150	(125)	176 (145)	202 (165)	M16 (M12)	17,5 (13,5)	30	--	30	25	155 (130)	178,5 (147,5)	73 ~ 110	60 ~ 90	TD_/TC_-S 10012-8-4
150	(125)	176 (145)	202 (165)	M16 (M12)	17,5 (13,5)	30	--	30	25	155 (130)	178,5 (147,5)	81 ~ 121	67 ~ 100	TD_/TC_-S 10012-8-5
150	(125)	176 (145)	202 (165)	M16 (M12)	17,5 (13,5)	30	--	30	25	155 (130)	178,5 (147,5)	88 ~ 132	75 ~ 112	TD_/TC_-S 10012-8-6
150	(125)	176 (145)	202 (165)	M16 (M12)	17,5 (13,5)	30	--	30	25	155 (130)	178,5 (147,5)	95 ~ 142	83 ~ 125	TD_/TC_-S 10012-8-7
150	(125)	176 (145)	202 (165)	M16 (M12)	17,5 (13,5)	30	--	30	25	155 (130)	178,5 (147,5)	102 ~ 153	--	TD_-S 10012-8-8
150	(125)	176 (145)	202 (165)	M16 (M12)	17,5 (13,5)	30	--	30	25	155 (130)	178,5 (147,5)	55 ~ 83	40 ~ 60	TD_/TC_-S 10016-8-2
150	(125)	176 (145)	202 (165)	M16 (M12)	17,5 (13,5)	30	--	30	25	155 (130)	178,5 (147,5)	67 ~ 101	58 ~ 86	TD_/TC_-S 10016-8-3
150	(125)	176 (145)	202 (165)	M16 (M12)	17,5 (13,5)	30	--	30	25	155 (130)	178,5 (147,5)	77 ~ 116	67 ~ 101	TD_/TC_-S 10016-8-4
150	(125)	176 (145)	202 (165)	M16 (M12)	17,5 (13,5)	30	--	30	25	155 (130)	178,5 (147,5)	87 ~ 130	76 ~ 115	TD_/TC_-S 10016-8-5
150	(125)	176 (145)	202 (165)	M16 (M12)	17,5 (13,5)	30	--	30	25	155 (130)	178,5 (147,5)	96 ~ 145	--	TD_-S 10016-8-6
150	(125)	176 (145)	202 (165)	M16 (M12)	17,5 (13,5)	30	--	30	25	155 (130)	178,5 (147,5)	105 ~ 158	--	TD_-S 10016-8-7
150	(125)	176 (145)	202 (165)	M16 (M12)	17,5 (13,5)	30	--	30	25	155 (130)	178,5 (147,5)	115 ~ 172	--	TD_-S 10016-8-8
150	(130)	176 (150)	202 (170)	M16 (M12)	17,5 (13,5)	30	--	30	25	155 (135)	178,5 (152,5)	75 ~ 112	55 ~ 82	TD_/TC_-S 10020-9-2
150	(130)	176 (150)	202 (170)	M16 (M12)	17,5 (13,5)	30	--	30	25	155 (135)	178,5 (152,5)	92 ~ 138	81 ~ 121	TD_/TC_-S 10020-9-3
150	(130)	176 (150)	202 (170)	M16 (M12)	17,5 (13,5)	30	--	30	25	155 (135)	178,5 (152,5)	107 ~ 161	96 ~ 144	TD_/TC_-S 10020-9-4
150	(130)	176 (150)	202 (170)	M16 (M12)	17,5 (13,5)	30	--	30	25	155 (135)	178,5 (152,5)	122 ~ 183	--	TD_-S 10020-9-5
150	(130)	176 (150)	202 (170)	M16 (M12)	17,5 (13,5)	30	--	30	25	155 (135)	178,5 (152,5)	137 ~ 205	--	TD_-S 10020-9-6
150	(130)	176 (150)	202 (170)	M16 (M12)	17,5 (13,5)	30	--	30	25	155 (135)	178,5 (152,5)	150 ~ 225	--	TD_-S 10020-9-7
150	(130)	176 (150)	202 (170)	M16 (M12)	17,5 (13,5)	30	--	30	25	155 (135)	178,5 (152,5)	164 ~ 247	--	TD_-S 10020-9-8

Key dimensions of the cylindrical nut: N, M, Y are obtained in the tables of page 38 of the catalogue.

SHUTON advises to use the dimensions of the tables, although it is possible to manufacture ball screw with other dimensions.

Smaller nut diameters than the first option of the table can reduce the rigidity of the assembly between 5 and 10%.

Please consult SHUTON.

SHUTON **HIGH LOADS**

High dynamics and HIGH LOAD ball screws for injection molding machines, presses and other heavy duty applications operated by electric servo drive in extreme conditions.





SHUTON HIGH LOADS

SHUTON HIGH LOADS

U-type recirculation system

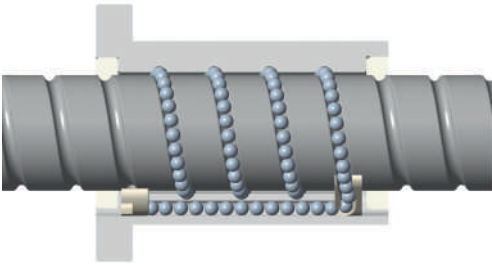

B-type recirculation system

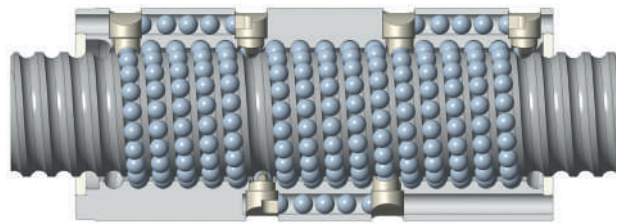

HIGH LOADS Single Nut

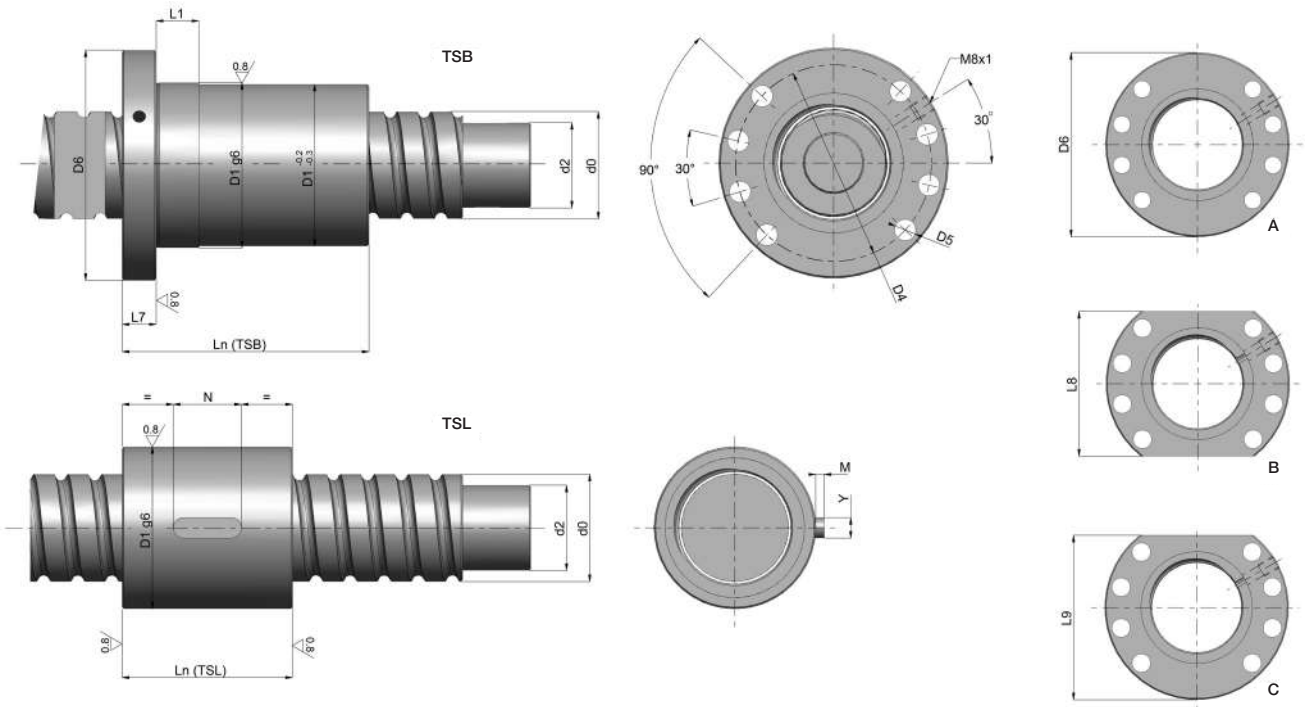

Types of HIGH LOADS nuts depending on application:

Technology	Sectors	Features	Preload	Nut type	Recirc.	Starts	Diameter	Lead	Ball size	Application		
HIGH LOADS	Injection machine Presses Semiconductor Elevators Actuators Machine tool	High dynamics and high load DN up to 170.000. → For applications operated by electric servo drive in extreme condition	NO	TS Single nut	HDL	U	1s	80-120	20-50	12	Very high load and moderate rotation speed applications, DN up to 140.000.	
						B	1s	63-160	16-32	12-25	Very high load and moderate rotation speed applications, DN up to 110.000.	
							2s	63-140	32-50	12-19	Very high load & high linear speed DN up to 110000	
						IML	U	1s	80-120	20-50	12	High load and very high rotation speed applications, DN up to 210.000.
							B	1s	50-160	12,7-25	9-19	High load and high rotation speed applications, DN up to 170.000
						2s		63-140	25-50	9-19	High load and very high linear speed applications, DN up to 170.000	
						PKL	B	1s	63-160	20-32	15-25	Momentary especially extreme peak loads. DN up to 170.000

Depending on the application requirement of load capacity and speed, and in order to obtain the optimum life results in each case, SHUTON has developed three different types of HIGH LOAD ball screws:

HIGH LOAD IML → Specially designed for HIGH LOAD and high speed applications, DN up to 170.000.

HIGH LOAD HDL→ Specially designed for very HIGH LOAD and moderate speed applications, DN up to 110.000.

HIGH LOAD PKL→ Specially designed for applications with momentary especially extreme peak loads

HIGH LOADS, Single nut

Ball screw reference TSB Flanged single nut TSL Cylindrical single nut Recirculation U and B	No. Starts	Nominal diameter	Lead	Ball diameter	Root diameter	Circuits	IML Type				HDL Type			
							Dynamic load capacity [kN]	Static load capacity [kN]	Maximum recommended external force with loads CO-CO TR-TR [kN]	Maximum recommended external force with loads CO-TR [kN]	Dynamic load capacity [kN]	Static load capacity [kN]	Maximum recommended external force with loads CO-CO TR-TR [kN]	Maximum recommended external force with loads CO-TR [kN]
	$l/2$	d_0	P_h	D_w	d_2	$i (I_e)$	$C_a (kN)$	$C_{oa} (kN)$	F_{max,CO^2TR^2}	$F_{max,CO-TR}$	$C_a (kN)$	$C_{oa} (kN)$	F_{max,CO^2TR^2}	$F_{max,CO-TR}$
TS_-B 5012,7-9-2	1	50	12,7	9,525	42,2	2	62	108	35	35				
TS_-B 5012,7-9-3	1	50	12,7	9,525	42,2	3	88	173	55	55				
TS_-B 5012,7-9-4	1	50	12,7	9,525	42,2	4	114	239	75	75				
TS_-B 5012,7-9-5	1	50	12,7	9,525	42,2	5	140	308	100	95				
TS_-B 5012,7-9-6	1	50	12,7	9,525	42,2	6	165	374	120	120				
TS_-B 5012,7-9-7	1	50	12,7	9,525	42,2	7	189	439	130	130				
TS_-B 5012,7-9-8	1	50	12,7	9,525	42,2	8	205	478	150	150				
TS_-B 5012,7-9-9	1	50	12,7	9,525	42,2	9	229	547	170	170				
TS_-B 5012,7-9-10	1	50	12,7	9,525	42,2	10	253	616	190	190				
TS_-B 5012,7-9-11	1	50	12,7	9,525	42,2	11	274	678	210	210				
TS_-B 6312,7-9-2	1	63	12,7	9,525	55,2	2	71	141	46	46				
TS_-B 6312,7-9-3	1	63	12,7	9,525	55,2	3	101	227	75	75				
TS_-B 6312,7-9-4	1	63	12,7	9,525	55,2	4	129	309	100	100				
TS_-B 6312,7-9-5	1	63	12,7	9,525	55,2	5	158	395	120	120				
TS_-B 6312,7-9-6	1	63	12,7	9,525	55,2	6	179	454	140	140				
TS_-B 6312,7-9-7	1	63	12,7	9,525	55,2	7	206	540	170	170				
TS_-B 6312,7-9-8	1	63	12,7	9,525	55,2	8	232	618	200	200				
TS_-B 6312,7-9-9	1	63	12,7	9,525	55,2	9	258	704	220	220				
TS_-B 6312,7-9-10	1	63	12,7	9,525	55,2	10	285	790	250	240				
TS_-B 6312,7-9-11	1	63	12,7	9,525	55,2	11	303	845	270	270				
TS_-B 6312,7-9-12	1	63	12,7	9,525	55,2	12	328	927	300	290				
TS_-B 6312,7-9-13	1	63	12,7	9,525	55,2	13	355	1021	320	310				
TS_-B 6312,7-9-14	1	63	12,7	9,525	55,2	14	379	1103	350	340				
TS_-B 6312,7-9-15	1	63	12,7	9,525	55,2	15	403	1185	370	350				
TS_-B 6312,7-9-16	1	63	12,7	9,525	55,2	16	420	1236	390	380				
TS_-B 6312,7-9-17	1	63	12,7	9,525	55,2	17	446	1330	420	400				
TS_-B 6316-12-2	1	63	16	12,7	54	2	105	192	35	35	113	206	45	45
TS_-B 6316-12-3	1	63	16	12,7	54	3	148	306	55	55	163	341	75	75
TS_-B 6316-12-4	1	63	16	12,7	54	4	193	427	80	80	209	468	100	100
TS_-B 6316-12-5	1	63	16	12,7	54	5	237	548	100	100	255	594	130	130
TS_-B 6316-12-6	1	63	16	12,7	54	6	277	662	120	120	302	729	150	150
TS_-B 6316-12-7	1	63	16	12,7	54	7	319	782	140	140	346	856	180	180
TS_-B 6316-12-8	1	63	16	12,7	54	8	347	854	150	150	376	935	200	200
TS_-B 6316-12-9	1	63	16	12,7	54	9	385	967	170	170	419	1062	230	230
TS_-B 6316-12-10	1	63	16	12,7	54	10	427	1095	200	190	461	1189	260	250
TS_-B 6316-12-11	1	63	16	12,7	54	11	464	1209	210	210	506	1331	280	270

* C_a and C_{oa} : Modified static and dynamic load capacities, calculated according to DIN 69051/4 standard and ISO3408/5. See pages 39 and 43.

** Rb/t : Rigidity of the balls contact zone for an external force 20% of C_a . See page 46. For different forces, multiply by $\sqrt[3]{F/0,2 C_a}$

*** Rnu : Total rigidity of the complete nut. It must be multiplied by the factor f_{ar} , which depends on the manufacturing tolerance. See page 48.

**** Check with SHUTON in case higher loads or more adjusted nut dimensions are required.

***** Check external maximum axial force in the two senses.

For the indicated leads, in case C_a and C_{oa} requirements is lower, there is possibility of smaller size balls

Nut length	Nut dimensions, B-type recirculation, 8 hole design <small>*dimensions of 12 hole design check with Shuton</small>										Grease quantity TS 'steel ball'	Ball screw reference TSB Flanged single nut TSL Cylindrical single nut Recirculation U and B
	TSB	D_1	$D_{L,min}$	D_4	D_6	M	D_5	L_7	L_1	L_8		
65	85		105	125	M12	13,5	35	25	90	107,5	25	TS_-B 5012,7-9-2
78	85		105	125	M12	13,5	35	25	90	107,5	29	TS_-B 5012,7-9-3
91	85		105	125	M12	13,5	35	25	90	107,5	33	TS_-B 5012,7-9-4
103	85		105	125	M12	13,5	35	25	90	107,5	36	TS_-B 5012,7-9-5
116	85		105	125	M12	13,5	35	25	90	107,5	40	TS_-B 5012,7-9-6
129	85		105	125	M12	13,5	35	25	90	107,5	45	TS_-B 5012,7-9-7
148	85		105	125	M12	13,5	35	25	90	107,5	54	TS_-B 5012,7-9-8
161	85		105	125	M12	13,5	35	25	90	107,5	58	TS_-B 5012,7-9-9
173	85		105	125	M12	13,5	35	25	90	107,5	61	TS_-B 5012,7-9-10
182	85		105	125	M12	13,5	35	25	90	107,5	63	TS_-B 5012,7-9-11
65	100		120	140	M12	13,5	35	25	105	122,5	31	TS_-B 6312,7-9-2
78	100		120	140	M12	13,5	35	25	105	122,5	36	TS_-B 6312,7-9-3
91	100		120	140	M12	13,5	35	25	105	122,5	41	TS_-B 6312,7-9-4
103	100		120	140	M12	13,5	35	25	105	122,5	45	TS_-B 6312,7-9-5
123	100		120	140	M12	13,5	35	25	105	122,5	57	TS_-B 6312,7-9-6
135	100		120	140	M12	13,5	35	25	105	122,5	61	TS_-B 6312,7-9-7
148	100		120	140	M12	13,5	35	25	105	122,5	66	TS_-B 6312,7-9-8
161	100		120	140	M12	13,5	35	25	105	122,5	71	TS_-B 6312,7-9-9
173	100		120	140	M12	13,5	35	25	105	122,5	75	TS_-B 6312,7-9-10
188	100		120	140	M12	13,5	35	25	105	122,5	83	TS_-B 6312,7-9-11
201	100		120	140	M12	13,5	35	25	105	122,5	89	TS_-B 6312,7-9-12
214	100		120	140	M12	13,5	35	25	105	122,5	93	TS_-B 6312,7-9-13
226	100		120	140	M12	13,5	35	25	105	122,5	97	TS_-B 6312,7-9-14
239	100		120	140	M12	13,5	35	25	105	122,5	102	TS_-B 6312,7-9-15
253	100		120	140	M12	13,5	35	25	105	122,5	110	TS_-B 6312,7-9-16
265	100		120	140	M12	13,5	35	25	105	122,5	113	TS_-B 6312,7-9-17
75	110		130	150	M12	13,5	40	25	115	132,5	50	TS_-B 6316-12-2
91	110		130	150	M12	13,5	40	25	115	132,5	58	TS_-B 6316-12-3
107	110		130	150	M12	13,5	40	25	115	132,5	65	TS_-B 6316-12-4
123	110		130	150	M12	13,5	40	25	115	132,5	73	TS_-B 6316-12-5
139	110		130	150	M12	13,5	40	25	115	132,5	82	TS_-B 6316-12-6
155	110		130	150	M12	13,5	40	25	115	132,5	90	TS_-B 6316-12-7
179	110		130	150	M12	13,5	40	25	115	132,5	108	TS_-B 6316-12-8
195	110		130	150	M12	13,5	40	25	115	132,5	117	TS_-B 6316-12-9
211	110		130	150	M12	13,5	40	25	115	132,5	124	TS_-B 6316-12-10
227	110		130	150	M12	13,5	40	25	115	132,5	133	TS_-B 6316-12-11

Key dimensions of the cylindrical nut: N, M, Y are obtained in the tables of page 38 of the catalogue.

SHUTON advises to use the dimensions of the tables, although it is possible to manufacture ball screw with other dimensions. In brackets () second options. Smaller nut diameters than the first option of the table can reduce the rigidity of the assembly between 5 and 10%.

Please consult SHUTON.

HIGH LOADS, Single nut

Ball screw reference TSB Flanged single nut TSL Cylindrical single nut Recirculation U and B	No. Starts	Nominal diameter	Lead	Ball diameter	Root diameter	Circuits	IML Type				HDL Type			
							Dynamic load capacity [kN]	Static load capacity [kN]	Maximum recommended external force with loads CO-CO TR-TR [kN]	Maximum recommended external force with loads CO-TR [kN]	Dynamic load capacity [kN]	Static load capacity [kN]	Maximum recommended external force with loads CO-CO TR-TR [kN]	Maximum recommended external force with loads CO-TR [kN]
	$l/2$	d_0	P_h	D_w	d_2	$i (I_e)$	$C_a (kN)$	$C_{oa} (kN)$	F_{max,CO^2TR^2}	$F_{max,CO-TR}$	$C_a (kN)$	$C_{oa} (kN)$	F_{max,CO^2TR^2}	$F_{max,CO-TR}$
TS_-B 6316-12-12	1	63	16	12,7	54	12	501	1323	230	220	547	1458	300	290
TS_-B 6316-12-13	1	63	16	12,7	54	13	542	1451	250	240	587	1585	330	320
TS_-B 6316-12-14	1	63	16	12,7	54	14	578	1565	270	250	627	1712	350	330
TS_-B 6320-15-2	1	63	20	15,875	50	2	136	226	85	85	150	254	60	60
TS_-B 6320-15-3	1	63	20	15,875	50	3	196	373	140	140	215	419	100	100
TS_-B 6320-15-4	1	63	20	15,875	50	4	255	520	180	180	280	584	140	140
TS_-B 6320-15-5	1	63	20	15,875	50	5	313	667	240	230	344	749	170	170
TS_-B 6320-15-6	1	63	20	15,875	50	6	373	825	290	280	409	927	210	210
TS_-B 6320-15-7	1	63	20	15,875	50	7	428	972	330	330	470	1092	240	240
TS_-B 6320-15-8	1	63	20	15,875	50	8	482	1119	370	360	529	1257	270	270
TS_-B 6320-15-9	1	63	20	15,875	50	9	535	1266	410	400	587	1422	300	290
TS_-B 6320-15-10	1	63	20	15,875	50	10	565	1333	460	450	620	1498	340	330
TS_(2S)-B 6325-9-2	2	63	25	9,525	55,2	2	111	240	80	80				
TS_(2S)-B 6325-9-3	2	63	25	9,525	55,2	3	155	376	120	120				
TS_(2S)-B 6325-9-4	2	63	25	9,525	55,2	4	200	519	160	160				
TS_(2S)-B 6325-9-5	2	63	25	9,525	55,2	5	245	661	210	210				
TS_(2S)-B 6325-9-6	2	63	25	9,525	55,2	6	275	752	240	230				
TS_(2S)-B 6325-9-7	2	63	25	9,525	55,2	7	318	895	280	270				
TS_(2S)-B 6325-9-8	2	63	25	9,525	55,2	8	360	1037	320	310				
TS_(2S)-B 6325-9-9	2	63	25	9,525	55,2	9	401	1180	360	350				
TS_(2S)-B 6332-12-2	2	63	32	12,7	54	2	162	317	55	55	177	353	75	75
TS_(2S)-B 6332-12-3	2	63	32	12,7	54	3	231	517	95	95	249	563	120	120
TS_(2S)-B 6332-12-4	2	63	32	12,7	54	4	299	717	130	130	325	785	170	170
TS_(2S)-B 6332-12-5	2	63	32	12,7	54	5	363	905	160	160	395	995	210	210
TS_(2S)-B 6332-12-6	2	63	32	12,7	54	6	428	1105	190	190	467	1217	250	250
TS_(2S)-B 6332-12-7	2	63	32	12,7	54	7	492	1305	220	210	534	1427	290	280
TS_(2S)-B 6340-15-2	2	63	40	15,875	50	2	208	372	140	140	228	417	100	100
TS_(2S)-B 6340-15-3	2	63	40	15,875	50	3	305	632	230	220	335	710	170	170
TS_(2S)-B 6340-15-4	2	63	40	15,875	50	4	395	873	300	300	433	981	220	220
TS_(2S)-B 6340-15-5	2	63	40	15,875	50	5	482	1115	380	370	530	1252	280	270
TS_-B 7012,7-9-2	1	70	12,7	9,525	62,2	2	76	161	55	55				
TS_-B 7012,7-9-3	1	70	12,7	9,525	62,2	3	106	256	85	85				
TS_-B 7012,7-9-4	1	70	12,7	9,525	62,2	4	137	350	110	110				
TS_-B 7012,7-9-5	1	70	12,7	9,525	62,2	5	166	441	140	140				
TS_-B 7012,7-9-6	1	70	12,7	9,525	62,2	6	189	512	160	160				
TS_-B 7012,7-9-7	1	70	12,7	9,525	62,2	7	218	606	190	190				

* C_a and C_{oa} : Modified static and dynamic load capacities, calculated according to DIN 69051/4 standard and ISO3408/5. See pages 39 and 43.

** Rb/t : Rigidity of the balls contact zone for an external force 20% of C_a . See page 46. For different forces, multiply by $\sqrt[3]{F/0,2 C_a}$

*** Rnu : Total rigidity of the complete nut. It must be multiplied by the factor f_{an} , which depends on the manufacturing tolerance. See page 48.

**** Check with SHUTON in case higher loads or more adjusted nut dimensions are required.

***** Check external maximum axial force in the two senses.

For the indicated leads, in case C_a and C_{oa} requirements is lower, there is possibility of smaller size balls

Nut length	Nut dimensions, B-type recirculation, 8 hole design <small>*dimensions of 12 hole design check with Shuton</small>										Grease quantity TS 'steel ball'	Ball screw reference TSB Flanged single nut TSL Cylindrical single nut Recirculation U and B
	TSB	D_1	$D_{L,min}$	D_4	D_6	M	D_5	L_7	L_1	L_8		
243	110		130	150	M12	13,5	40	25	115	132,5	142	TS_-B 6316-12-12
259	110		130	150	M12	13,5	40	25	115	132,5	150	TS_-B 6316-12-13
271	110		130	150	M12	13,5	40	25	115	132,5	154	TS_-B 6316-12-14
89	120		140	160	M12	13,5	45	25	125	142,5	81	TS_-B 6320-15-2
109	120		140	160	M12	13,5	45	25	125	142,5	94	TS_-B 6320-15-3
129	120		140	160	M12	13,5	45	25	125	142,5	108	TS_-B 6320-15-4
149	120		140	160	M12	13,5	45	25	125	142,5	121	TS_-B 6320-15-5
169	120		140	160	M12	13,5	45	25	125	142,5	133	TS_-B 6320-15-6
189	120		140	160	M12	13,5	45	25	125	142,5	149	TS_-B 6320-15-7
209	120		140	160	M12	13,5	45	25	125	142,5	164	TS_-B 6320-15-8
229	120		140	160	M12	13,5	45	25	125	142,5	181	TS_-B 6320-15-9
259	120		140	160	M12	13,5	45	25	125	142,5	207	TS_-B 6320-15-10
92	100		120	140	M12	13,5	35	25	105	122,5	42	TS_(2S)-B 6325-9-2
117	100		120	140	M12	13,5	35	25	105	122,5	51	TS_(2S)-B 6325-9-3
142	100		120	140	M12	13,5	35	25	105	122,5	61	TS_(2S)-B 6325-9-4
167	100		120	140	M12	13,5	35	25	105	122,5	70	TS_(2S)-B 6325-9-5
204	100		120	140	M12	13,5	35	25	105	122,5	93	TS_(2S)-B 6325-9-6
229	100		120	140	M12	13,5	35	25	105	122,5	102	TS_(2S)-B 6325-9-7
254	100		120	140	M12	13,5	35	25	105	122,5	111	TS_(2S)-B 6325-9-8
271	100		120	140	M12	13,5	35	25	105	122,5	113	TS_(2S)-B 6325-9-9
109	110		130	150	M12	13,5	40	25	115	132,5	70	TS_(2S)-B 6332-12-2
141	110		130	150	M12	13,5	40	25	115	132,5	84	TS_(2S)-B 6332-12-3
173	110		130	150	M12	13,5	40	25	115	132,5	98	TS_(2S)-B 6332-12-4
205	110		130	150	M12	13,5	40	25	115	132,5	115	TS_(2S)-B 6332-12-5
237	110		130	150	M12	13,5	40	25	115	132,5	133	TS_(2S)-B 6332-12-6
269	110		130	150	M12	13,5	40	25	115	132,5	150	TS_(2S)-B 6332-12-7
131	120		140	160	M12	13,5	45	25	125	142,5	115	TS_(2S)-B 6340-15-2
171	120		140	160	M12	13,5	45	25	125	142,5	138	TS_(2S)-B 6340-15-3
211	120		140	160	M12	13,5	45	25	125	142,5	167	TS_(2S)-B 6340-15-4
251	120		140	160	M12	13,5	45	25	125	142,5	193	TS_(2S)-B 6340-15-5
65	110		130	150	M12	13,5	35	25	115	132,5	34	TS_-B 7012,7-9-2
78	110		130	150	M12	13,5	35	25	115	132,5	39	TS_-B 7012,7-9-3
91	110		130	150	M12	13,5	35	25	115	132,5	44	TS_-B 7012,7-9-4
103	110		130	150	M12	13,5	35	25	115	132,5	50	TS_-B 7012,7-9-5
123	110		130	150	M12	13,5	35	25	115	132,5	62	TS_-B 7012,7-9-6
135	110		130	150	M12	13,5	35	25	115	132,5	67	TS_-B 7012,7-9-7

Key dimensions of the cylindrical nut: N, M, Y are obtained in the tables of page 38 of the catalogue.

SHUTON advises to use the dimensions of the tables, although it is possible to manufacture ball screw with other dimensions. In brackets () second options. Smaller nut diameters than the first option of the table can reduce the rigidity of the assembly between 5 and 10%.

Please consult SHUTON.

HIGH LOADS, Single nut

Ball screw reference TSB Flanged single nut TSL Cylindrical single nut Recirculation U and B	No. Starts	Nominal diameter	Lead	Ball diameter	Root diameter	Circuits	IML Type				HDL Type			
							Dynamic load capacity [kN]	Static load capacity [kN]	Maximum recommended external force with loads CO-CO TR-TR [kN]	Maximum recommended external force with loads CO-TR [kN]	Dynamic load capacity [kN]	Static load capacity [kN]	Maximum recommended external force with loads CO-CO TR-TR [kN]	Maximum recommended external force with loads CO-TR [kN]
	$l/2$	d_0	P_h	D_w	d_2	$i (I_e)$	$C_a (kN)$	$C_{oa} (kN)$	F_{max,CO^2TR^2}	$F_{max,CO-TR}$	$C_a (kN)$	$C_{oa} (kN)$	F_{max,CO^2TR^2}	$F_{max,CO-TR}$
TS_-B 7012,7-9-8	1	70	12,7	9,525	62,2	8	246	700	220	220				
TS_-B 7012,7-9-9	1	70	12,7	9,525	62,2	9	273	795	250	250				
TS_-B 7012,7-9-10	1	70	12,7	9,525	62,2	10	299	881	270	270				
TS_-B 7012,7-9-11	1	70	12,7	9,525	62,2	11	321	956	300	300				
TS_-B 7012,7-9-12	1	70	12,7	9,525	62,2	12	348	1051	330	330				
TS_-B 7012,7-9-13	1	70	12,7	9,525	62,2	13	374	1145	360	350				
TS_-B 7012,7-9-14	1	70	12,7	9,525	62,2	14	400	1239	390	380				
TS_-B 7012,7-9-15	1	70	12,7	9,525	62,2	15	423	1322	410	400				
TS_-B 7012,7-9-16	1	70	12,7	9,525	62,2	16	445	1401	440	420				
TS_-B 7016-12-2	1	70	16	12,7	61	2	111	215	40	40	122	240	50	50
TS_-B 7016-12-3	1	70	16	12,7	61	3	159	351	65	65	172	383	85	85
TS_-B 7016-12-4	1	70	16	12,7	61	4	204	480	90	85	222	527	110	110
TS_-B 7016-12-5	1	70	16	12,7	61	5	249	609	110	110	271	671	140	140
TS_-B 7016-12-6	1	70	16	12,7	61	6	294	745	130	130	319	814	170	170
TS_-B 7016-12-7	1	70	16	12,7	61	7	337	874	150	150	366	958	200	200
TS_-B 7016-12-8	1	70	16	12,7	61	8	368	960	170	170	400	1054	230	220
TS_-B 7016-12-9	1	70	16	12,7	61	9	409	1089	190	190	445	1198	260	250
TS_-B 7016-12-10	1	70	16	12,7	61	10	449	1218	220	210	490	1341	280	280
TS_-B 7016-12-11	1	70	16	12,7	61	11	489	1347	230	230	534	1485	310	310
TS_-B 7016-12-12	1	70	16	12,7	61	12	532	1490	260	250	577	1629	340	330
TS_-B 7016-12-13	1	70	16	12,7	61	13	571	1619	280	270	620	1773	360	350
TS_-B 7020-15-2	1	70	20	15,875	57	2	149	263	95	95	163	295	70	70
TS_-B 7020-15-3	1	70	20	15,875	57	3	210	422	150	150	231	474	110	110
TS_-B 7020-15-4	1	70	20	15,875	57	4	275	594	210	210	302	667	160	160
TS_-B 7020-15-5	1	70	20	15,875	57	5	335	753	260	260	368	846	190	190
TS_-B 7020-15-6	1	70	20	15,875	57	6	397	925	320	310	435	1038	230	230
TS_-B 7020-15-7	1	70	20	15,875	57	7	454	1084	370	360	498	1218	270	270
TS_-B 7020-15-8	1	70	20	15,875	57	8	513	1256	420	410	563	1410	310	300
TS_-B 7020-15-9	1	70	20	15,875	57	9	550	1347	470	450	603	1513	350	340
TS_-B 7020-15-10	1	70	20	15,875	57	10	605	1507	520	500	663	1692	380	370
TS_(2S)-B 7025-9-2	2	70	25	9,525	62,2	2	117	268	90	90				
TS_(2S)-B 7025-9-3	2	70	25	9,525	62,2	3	164	424	140	140				
TS_(2S)-B 7025-9-4	2	70	25	9,525	62,2	4	211	581	180	180				
TS_(2S)-B 7025-9-5	2	70	25	9,525	62,2	5	257	738	230	230				
TS_(2S)-B 7025-9-6	2	70	25	9,525	62,2	6	291	849	270	270				
TS_(2S)-B 7025-9-7	2	70	25	9,525	62,2	7	336	1005	320	310				

* C_a and C_{oa} : Modified static and dynamic load capacities, calculated according to DIN 69051/4 standard and ISO3408/5. See pages 39 and 73.

** R_b/t : Rigidity of the balls contact zone for an external force 20% of C_a . See page 46. For different forces, multiply by $\sqrt[3]{F/0,2 C_a}$

*** R_{nu} : Total rigidity of the complete nut. It must be multiplied by the factor f_{ar} , which depends on the manufacturing tolerance. See page 48.

**** Check with SHUTON in case higher loads or more adjusted nut dimensions are required.

***** Check external maximum axial force in the two senses.

For the indicated leads, in case C_a and C_{oa} requirements is lower, there is possibility of smaller size balls

Nut length	Nut dimensions, B-type recirculation, 8 hole design <small>*dimensions of 12 hole design check with Shuton</small>										Grease quantity TS 'steel ball'	Ball screw reference TSB Flanged single nut TSL Cylindrical single nut Recirculation U and B
	TSB	D_1	$D_{L,min}$	D_4	D_6	M	D_5	L_7	L_1	L_8		
148	110		130	150	M12	13,5	35	25	115	132,5	72	TS_-B 7012,7-9-8
161	110		130	150	M12	13,5	35	25	115	132,5	78	TS_-B 7012,7-9-9
173	110		130	150	M12	13,5	35	25	115	132,5	83	TS_-B 7012,7-9-10
188	110		130	150	M12	13,5	35	25	115	132,5	91	TS_-B 7012,7-9-11
201	110		130	150	M12	13,5	35	25	115	132,5	96	TS_-B 7012,7-9-12
214	110		130	150	M12	13,5	35	25	115	132,5	102	TS_-B 7012,7-9-13
226	110		130	150	M12	13,5	35	25	115	132,5	107	TS_-B 7012,7-9-14
239	110		130	150	M12	13,5	35	25	115	132,5	113	TS_-B 7012,7-9-15
253	110		130	150	M12	13,5	35	25	115	132,5	119	TS_-B 7012,7-9-16
75	120		140	160	M12	13,5	40	25	125	142,5	55	TS_-B 7016-12-2
91	120		140	160	M12	13,5	40	25	125	142,5	63	TS_-B 7016-12-3
107	120		140	160	M12	13,5	40	25	125	142,5	72	TS_-B 7016-12-4
123	120		140	160	M12	13,5	40	25	125	142,5	81	TS_-B 7016-12-5
139	120		140	160	M12	13,5	40	25	125	142,5	90	TS_-B 7016-12-6
155	120		140	160	M12	13,5	40	25	125	142,5	100	TS_-B 7016-12-7
179	120		140	160	M12	13,5	40	25	125	142,5	119	TS_-B 7016-12-8
195	120		140	160	M12	13,5	40	25	125	142,5	128	TS_-B 7016-12-9
211	120		140	160	M12	13,5	40	25	125	142,5	137	TS_-B 7016-12-10
227	120		140	160	M12	13,5	40	25	125	142,5	148	TS_-B 7016-12-11
243	120		140	160	M12	13,5	40	25	125	142,5	155	TS_-B 7016-12-12
259	120		140	160	M12	13,5	40	25	125	142,5	165	TS_-B 7016-12-13
89	130		150	170	M12	13,5	45	25	135	152,5	88	TS_-B 7020-15-2
109	130		150	170	M12	13,5	45	25	135	152,5	104	TS_-B 7020-15-3
129	130		150	170	M12	13,5	45	25	135	152,5	117	TS_-B 7020-15-4
149	130		150	170	M12	13,5	45	25	135	152,5	133	TS_-B 7020-15-5
169	130		150	170	M12	13,5	45	25	135	152,5	147	TS_-B 7020-15-6
189	130		150	170	M12	13,5	45	25	135	152,5	165	TS_-B 7020-15-7
209	130		150	170	M12	13,5	45	25	135	152,5	180	TS_-B 7020-15-8
229	130		150	170	M12	13,5	45	25	135	152,5	196	TS_-B 7020-15-9
259	130		153	176	M14	15,5	45	25	135	155,5	228	TS_-B 7020-15-10
92	110		130	150	M12	13,5	35	25	115	132,5	46	TS_(2S)-B 7025-9-2
117	110		130	150	M12	13,5	35	25	115	132,5	56	TS_(2S)-B 7025-9-3
142	110		130	150	M12	13,5	35	25	115	132,5	66	TS_(2S)-B 7025-9-4
167	110		130	150	M12	13,5	35	25	115	132,5	77	TS_(2S)-B 7025-9-5
204	110		130	150	M12	13,5	35	25	115	132,5	101	TS_(2S)-B 7025-9-6
229	110		130	150	M12	13,5	35	25	115	132,5	111	TS_(2S)-B 7025-9-7

Key dimensions of the cylindrical nut: N, M, Y are obtained in the tables of page 38 of the catalogue.

SHUTON advises to use the dimensions of the tables, although it is possible to manufacture ball screw with other dimensions. In brackets () second options. Smaller nut diameters than the first option of the table can reduce the rigidity of the assembly between 5 and 10%.

Please consult SHUTON.

HIGH LOADS, Single nut

Ball screw reference TSB Flanged single nut TSL Cylindrical single nut Recirculation U and B	No. Starts	Nominal diameter	Lead	Ball diameter	Root diameter	Circuits	IML Type				HDL Type			
							Dynamic load capacity [kN]	Static load capacity [kN]	Maximum recommended external force with loads CO-CO TR-TR [kN]	Maximum recommended external force with loads CO-TR [kN]	Dynamic load capacity [kN]	Static load capacity [kN]	Maximum recommended external force with loads CO-CO TR-TR [kN]	Maximum recommended external force with loads CO-TR [kN]
	$l/2$	d_0	P_h	D_w	d_2	$i (I_e)$	$C_a (kN)$	$C_{oa} (kN)$	F_{max,CO^2TR^2}	$F_{max,CO-TR}$	$C_a (kN)$	$C_{oa} (kN)$	F_{max,CO^2TR^2}	$F_{max,CO-TR}$
TS_(2S)-B 7025-9-8	2	70	25	9,525	62,2	8	379	1162	360	350				
TS_(2S)-B 7025-9-9	2	70	25	9,525	62,2	9	422	1319	400	380				
TS_(2S)-B 7032-12-2	2	70	32	12,7	61	2	171	356	65	65	188	396	85	85
TS_(2S)-B 7032-12-3	2	70	32	12,7	61	3	245	581	110	110	265	634	140	140
TS_(2S)-B 7032-12-4	2	70	32	12,7	61	4	314	795	140	140	342	872	190	190
TS_(2S)-B 7032-12-5	2	70	32	12,7	61	5	386	1020	180	180	420	1123	240	230
TS_(2S)-B 7032-12-6	2	70	32	12,7	61	6	452	1233	210	210	494	1361	280	270
TS_(2S)-B 7032-12-7	2	70	32	12,7	61	7	520	1459	240	230	566	1599	320	310
TS_(2S)-B 7040-15-2	2	70	40	15,875	57	2	227	433	160	160	249	486	120	120
TS_(2S)-B 7040-15-3	2	70	40	15,875	57	3	327	715	250	250	359	803	180	180
TS_(2S)-B 7040-15-4	2	70	40	15,875	57	4	421	978	340	330	462	1099	250	250
TS_(2S)-B 7040-15-5	2	70	40	15,875	57	5	517	1260	430	410	568	1416	320	310
TS_-B 8012,7-9-2	1	80	12,7	9,525	72,2	2	82	190	60	60				
TS_-B 8012,7-9-3	1	80	12,7	9,525	72,2	3	114	297	95	95				
TS_-B 8012,7-9-4	1	80	12,7	9,525	72,2	4	146	404	130	130				
TS_-B 8012,7-9-5	1	80	12,7	9,525	72,2	5	170	483	150	150				
TS_-B 8012,7-9-6	1	80	12,7	9,525	72,2	6	202	594	190	190				
TS_-B 8012,7-9-7	1	80	12,7	9,525	72,2	7	231	697	220	220				
TS_-B 8012,7-9-8	1	80	12,7	9,525	72,2	8	262	808	260	260				
TS_-B 8012,7-9-9	1	80	12,7	9,525	72,2	9	285	891	280	280				
TS_-B 8012,7-9-10	1	80	12,7	9,525	72,2	10	314	998	320	310				
TS_-B 8012,7-9-11	1	80	12,7	9,525	72,2	11	342	1105	350	340				
TS_-B 8012,7-9-12	1	80	12,7	9,525	72,2	12	370	1212	380	380				
TS_-B 8012,7-9-13	1	80	12,7	9,525	72,2	13	394	1299	410	400				
TS_-B 8012,7-9-14	1	80	12,7	9,525	72,2	14	419	1394	440	430				
TS_-B 8012,7-9-15	1	80	12,7	9,525	72,2	15	446	1505	470	450				
TS_-B 8012,7-9-16	1	80	12,7	9,525	72,2	16	474	1616	500	480				
TS_-B 8016-12-2	1	80	16	12,7	71	2	121	253	46	46	133	282	65	65
TS_-B 8016-12-3	1	80	16	12,7	71	3	170	405	75	75	185	443	95	95
TS_-B 8016-12-4	1	80	16	12,7	71	4	219	556	100	100	239	612	130	130
TS_-B 8016-12-5	1	80	16	12,7	71	5	268	708	130	130	290	773	170	170
TS_-B 8016-12-6	1	80	16	12,7	71	6	313	853	150	150	342	942	200	200
TS_-B 8016-12-7	1	80	16	12,7	71	7	347	954	170	170	381	1063	230	230
TS_-B 8016-12-8	1	80	16	12,7	71	8	394	1113	200	200	430	1224	260	260
TS_-B 8016-12-9	1	80	16	12,7	71	9	437	1257	220	220	477	1385	300	290
TS_-B 8016-12-10	1	80	16	12,7	71	10	483	1416	250	250	524	1546	330	320

* C_a and C_{oa} : Modified static and dynamic load capacities, calculated according to DIN 69051/4 standard and ISO3408/5. See pages 39 and 43.

** Rb/t : Rigidity of the balls contact zone for an external force 20% of C_a . See page 46. For different forces, multiply by $\sqrt[3]{F/0,2 C_a}$

*** Rnu : Total rigidity of the complete nut. It must be multiplied by the factor f_{an} , which depends on the manufacturing tolerance. See page 48.

**** Check with SHUTON in case higher loads or more adjusted nut dimensions are required.

***** Check external maximum axial force in the two senses.

For the indicated leads, in case C_a and C_{oa} requirements is lower, there is possibility of smaller size balls

Nut length	Nut dimensions, B-type recirculation, 8 hole design <small>*dimensions of 12 hole design check with Shuton</small>										Grease quantity TS 'steel ball'	Ball screw reference TSB Flanged single nut TSL Cylindrical single nut Recirculation U and B
	TSB	D_1	$D_{L,min}$	D_4	D_6	M	D_5	L_7	L_1	L_8		
254	110		130	150	M12	13,5	35	25	115	132,5	121	TS_(2S)-B 7025-9-8
271	110		130	150	M12	13,5	35	25	115	132,5	125	TS_(2S)-B 7025-9-9
109	120		140	160	M12	13,5	40	25	125	142,5	76	TS_(2S)-B 7032-12-2
141	120		140	160	M12	13,5	40	25	125	142,5	92	TS_(2S)-B 7032-12-3
173	120		140	160	M12	13,5	40	25	125	142,5	110	TS_(2S)-B 7032-12-4
205	120		140	160	M12	13,5	40	25	125	142,5	126	TS_(2S)-B 7032-12-5
237	120		140	160	M12	13,5	40	25	125	142,5	146	TS_(2S)-B 7032-12-6
269	120		140	160	M12	13,5	40	25	125	142,5	165	TS_(2S)-B 7032-12-7
131	130		150	170	M12	13,5	45	25	135	152,5	124	TS_(2S)-B 7040-15-2
171	130		150	170	M12	13,5	45	25	135	152,5	153	TS_(2S)-B 7040-15-3
211	130		150	170	M12	13,5	45	25	135	152,5	183	TS_(2S)-B 7040-15-4
251	130		150	170	M12	13,5	45	25	135	152,5	212	TS_(2S)-B 7040-15-5
65	120		140	160	M12	13,5	35	25	125	142,5	38	TS_-B 8012,7-9-2
78	120		140	160	M12	13,5	35	25	125	142,5	44	TS_-B 8012,7-9-3
91	120		140	160	M12	13,5	35	25	125	142,5	50	TS_-B 8012,7-9-4
110	120		140	160	M12	13,5	35	25	125	142,5	65	TS_-B 8012,7-9-5
123	120		140	160	M12	13,5	35	25	125	142,5	71	TS_-B 8012,7-9-6
135	120		140	160	M12	13,5	35	25	125	142,5	76	TS_-B 8012,7-9-7
148	120		140	160	M12	13,5	35	25	125	142,5	82	TS_-B 8012,7-9-8
163	120		140	160	M12	13,5	35	25	125	142,5	92	TS_-B 8012,7-9-9
175	120		140	160	M12	13,5	35	25	125	142,5	97	TS_-B 8012,7-9-10
188	120		140	160	M12	13,5	35	25	125	142,5	103	TS_-B 8012,7-9-11
201	120		140	160	M12	13,5	35	25	125	142,5	109	TS_-B 8012,7-9-12
215	120		140	160	M12	13,5	35	25	125	142,5	117	TS_-B 8012,7-9-13
227	120		140	160	M12	13,5	35	25	125	142,5	124	TS_-B 8012,7-9-14
240	120		140	160	M12	13,5	35	25	125	142,5	130	TS_-B 8012,7-9-15
253	120		140	160	M12	13,5	35	25	125	142,5	135	TS_-B 8012,7-9-16
75	130		150	170	M12	13,5	40	25	135	152,5	62	TS_-B 8016-12-2
91	130		150	170	M12	13,5	40	25	135	152,5	71	TS_-B 8016-12-3
107	130		150	170	M12	13,5	40	25	135	152,5	81	TS_-B 8016-12-4
123	130		150	170	M12	13,5	40	25	135	152,5	91	TS_-B 8016-12-5
139	130		150	170	M12	13,5	40	25	135	152,5	102	TS_-B 8016-12-6
163	130		150	170	M12	13,5	40	25	135	152,5	126	TS_-B 8016-12-7
179	130		150	170	M12	13,5	40	25	135	152,5	134	TS_-B 8016-12-8
195	130		150	170	M12	13,5	40	25	135	152,5	145	TS_-B 8016-12-9
211	130		150	170	M12	13,5	40	25	135	152,5	154	TS_-B 8016-12-10

Key dimensions of the cylindrical nut: N, M, Y are obtained in the tables of page 38 of the catalogue.

SHUTON advises to use the dimensions of the tables, although it is possible to manufacture ball screw with other dimensions. In brackets () second options. Smaller nut diameters than the first option of the table can reduce the rigidity of the assembly between 5 and 10%.

Please consult SHUTON.

HIGH LOADS, Single nut

Ball screw reference TSB Flanged single nut TSL Cylindrical single nut Recirculation U and B	No. Starts	Nominal diameter	Lead	Ball diameter	Root diameter	Circuits	IML Type				HDL Type			
							Dynamic load capacity [kN]	Static load capacity [kN]	Maximum recommended external force with loads CO-CO TR-TR [kN]	Maximum recommended external force with loads CO-TR [kN]	Dynamic load capacity [kN]	Static load capacity [kN]	Maximum recommended external force with loads CO-CO TR-TR [kN]	Maximum recommended external force with loads CO-TR [kN]
	$l/2$	d_0	P_h	D_w	d_2	$i (I_e)$	$C_a (kN)$	$C_{oa} (kN)$	F_{max,CO^2TR^2}	$F_{max,CO-TR}$	$C_a (kN)$	$C_{oa} (kN)$	F_{max,CO^2TR^2}	$F_{max,CO-TR}$
TS_-B 8016-12-11	1	80	16	12,7	71	11	525	1561	270	260	573	1723	360	350
TS_-B 8016-12-12	1	80	16	12,7	71	12	566	1705	300	290	619	1884	390	380
TS_-B 8016-12-13	1	80	16	12,7	71	13	601	1821	320	310	655	2005	420	410
TS_-B 8016-12-14	1	80	16	12,7	71	14	643	1972	340	330	701	2174	450	430
TS_-B 8016-12-15	1	80	16	12,7	71	15	684	2124	370	350	742	2319	480	460
TS_-B 8016-12-16	1	80	16	12,7	71	16	725	2276	390	370	787	2488	510	480
TS_-B 8016-12-17	1	80	16	12,7	71	17	761	2406	410	380	832	2658	540	500
TS_-B 8016-12-18	1	80	16	12,7	71	18	802	2558	430	400	877	2827	570	530
TS_-B 8016-12-19	1	80	16	12,7	71	19	832	2659	450	420	907	2931	590	550
TS_-B 8020-15-2	1	80	20	15,875	67	2	163	312	110	110	179	350	80	80
TS_-B 8020-15-3	1	80	20	15,875	67	3	229	496	180	180	251	557	130	130
TS_-B 8020-15-4	1	80	20	15,875	67	4	298	693	250	250	327	778	180	180
TS_-B 8020-15-5	1	80	20	15,875	67	5	363	877	310	310	398	985	230	230
TS_-B 8020-15-6	1	80	20	15,875	67	6	429	1073	370	370	470	1205	270	270
TS_-B 8020-15-7	1	80	20	15,875	67	7	491	1258	430	420	538	1413	320	310
TS_-B 8020-15-8	1	80	20	15,875	67	8	536	1385	490	480	588	1555	360	350
TS_-B 8020-15-9	1	80	20	15,875	67	9	596	1570	550	530	654	1763	400	390
TS_-B 8020-15-10	1	80	20	15,875	67	10	655	1754	610	590	718	1970	450	430
TS_-B 8020-15-11	1	80	20	15,875	67	11	713	1939	650	630	782	2177	480	460
TS_-B 8020-15-12	1	80	20	15,875	67	12	776	2147	720	680	851	2411	530	500
TS_-B 8020-15-13	1	80	20	15,875	67	13	832	2331	760	720	913	2618	560	530
TS_-B 8020-15-14	1	80	20	15,875	67	14	888	2516	820	760	974	2825	600	560
TS_-B 8020-15-15	1	80	20	15,875	67	15	928	2631	880	810	1017	2955	640	590
TS_-B 8025-19-2	1	80	25	19,05	64,1	2	195	344	150	150	219	398	100	100
TS_-B 8025-19-3	1	80	25	19,05	64,1	3	282	573	240	240	318	664	160	160
TS_-B 8025-19-4	1	80	25	19,05	64,1	4	368	802	330	320	415	930	220	220
TS_-B 8025-19-5	1	80	25	19,05	64,1	5	452	1031	420	410	509	1195	290	280
TS_-B 8025-19-6	1	80	25	19,05	64,1	6	534	1260	500	490	602	1461	340	330
TS_-B 8025-19-7	1	80	25	19,05	64,1	7	610	1472	570	560	687	1707	390	380
TS_-B 8025-19-8	1	80	25	19,05	64,1	8	689	1701	640	620	776	1973	440	420
TS_-B 8025-19-9	1	80	25	19,05	64,1	9	766	1930	700	680	863	2238	480	460
TS_-B 8025-19-10	1	80	25	19,05	64,1	10	816	2061	810	770	919	2390	550	530
TS_-B 8025-19-11	1	80	25	19,05	64,1	11	892	2290	890	830	1005	2656	610	570
TS_-B 8025-19-12	1	80	25	19,05	64,1	12	966	2519	940	870	1088	2921	640	590
TS_(2S)-B 8025-9-2	2	80	25	9,525	72,2	2	127	316	100	100				
TS_(2S)-B 8025-9-3	2	80	25	9,525	72,2	3	176	493	160	160				

* C_a and C_{oa} : Modified static and dynamic load capacities, calculated according to DIN 69051/4 standard and ISO3408/5. See pages 39 and 43.

** Rb/t : Rigidity of the balls contact zone for an external force 20% of C_a . See page 46. For different forces, multiply by $\sqrt[3]{F/0,2 C_a}$

*** Rnu : Total rigidity of the complete nut. It must be multiplied by the factor f_{an} , which depends on the manufacturing tolerance. See page 48.

**** Check with SHUTON in case higher loads or more adjusted nut dimensions are required.

***** Check external maximum axial force in the two senses.

For the indicated leads, in case C_a and C_{oa} requirements is lower, there is possibility of smaller size balls

Nut length	Nut dimensions, B-type recirculation, 8 hole design <small>*dimensions of 12 hole design check with Shuton</small>										Grease quantity TS 'steel ball'	Ball screw reference TSB Flanged single nut TSL Cylindrical single nut Recirculation U and B
	TSB	D_1	$D_{L,min}$	D_4	D_6	M	D_5	L_7	L_1	L_8		
227	130		150	170	M12	13,5	40	25	135	152,5	165	TS_-B 8016-12-11
243	130		150	170	M12	13,5	40	25	135	152,5	176	TS_-B 8016-12-12
262	130		150	170	M12	13,5	40	25	135	152,5	189	TS_-B 8016-12-13
278	130		150	170	M12	13,5	40	25	135	152,5	199	TS_-B 8016-12-14
294	130		150	170	M12	13,5	40	25	135	152,5	209	TS_-B 8016-12-15
310	130		150	170	M12	13,5	40	25	135	152,5	220	TS_-B 8016-12-16
326	130		153	176	M14	15,5	40	25	135	155,5	232	TS_-B 8016-12-17
342	130		153	176	M14	15,5	40	25	135	155,5	242	TS_-B 8016-12-18
357	130		153	176	M14	15,5	40	25	135	155,5	251	TS_-B 8016-12-19
89	140		166	192	M16	17,5	45	25	145	168,5	100	TS_-B 8020-15-2
109	140		166	192	M16	17,5	45	25	145	168,5	116	TS_-B 8020-15-3
129	140		166	192	M16	17,5	45	25	145	168,5	131	TS_-B 8020-15-4
149	140		166	192	M16	17,5	45	25	145	168,5	148	TS_-B 8020-15-5
169	140		166	192	M16	17,5	45	25	145	168,5	166	TS_-B 8020-15-6
189	140		166	192	M16	17,5	45	25	145	168,5	185	TS_-B 8020-15-7
219	140		166	192	M16	17,5	45	25	145	168,5	219	TS_-B 8020-15-8
239	140		166	192	M16	17,5	45	25	145	168,5	237	TS_-B 8020-15-9
259	140		166	192	M16	17,5	45	25	145	168,5	254	TS_-B 8020-15-10
279	140		166	192	M16	17,5	45	25	145	168,5	274	TS_-B 8020-15-11
299	140		166	192	M16	17,5	45	25	145	168,5	289	TS_-B 8020-15-12
319	140		166	192	M16	17,5	45	25	145	168,5	309	TS_-B 8020-15-13
339	140		166	192	M16	17,5	45	25	145	168,5	327	TS_-B 8020-15-14
356	140		166	192	M16	17,5	45	25	145	168,5	336	TS_-B 8020-15-15
105	150		176	202	M16	17,5	50	40	155	178,5	143	TS_-B 8025-19-2
130	150		176	202	M16	17,5	50	40	155	178,5	166	TS_-B 8025-19-3
155	150		176	202	M16	17,5	50	40	155	178,5	190	TS_-B 8025-19-4
180	150		176	202	M16	17,5	50	40	155	178,5	213	TS_-B 8025-19-5
205	150		176	202	M16	17,5	50	40	155	178,5	240	TS_-B 8025-19-6
230	150		176	202	M16	17,5	50	40	155	178,5	267	TS_-B 8025-19-7
255	150		176	202	M16	17,5	50	40	155	178,5	297	TS_-B 8025-19-8
280	150		176	202	M16	17,5	50	40	155	178,5	327	TS_-B 8025-19-9
318	150		176	202	M16	17,5	50	40	155	178,5	370	TS_-B 8025-19-10
343	150		176	202	M16	17,5	50	40	155	178,5	395	TS_-B 8025-19-11
360	150		176	202	M16	17,5	50	40	155	178,5	407	TS_-B 8025-19-12
92	120		140	160	M12	13,5	35	25	125	142,5	52	TS_(2S)-B 8025-9-2
117	120		140	160	M12	13,5	35	25	125	142,5	64	TS_(2S)-B 8025-9-3

Key dimensions of the cylindrical nut: N, M, Y are obtained in the tables of page 38 of the catalogue.

SHUTON advises to use the dimensions of the tables, although it is possible to manufacture ball screw with other dimensions. In brackets () second options. Smaller nut diameters than the first option of the table can reduce the rigidity of the assembly between 5 and 10%.

Please consult SHUTON.

HIGH LOADS, Single nut

Ball screw reference TSB Flanged single nut TSL Cylindrical single nut Recirculation U and B	No. Starts	Nominal diameter	Lead	Ball diameter	Root diameter	Circuits	IML Type				HDL Type			
							Dynamic load capacity [kN]	Static load capacity [kN]	Maximum recommended external force with loads CO-CO TR-TR [kN]	Maximum recommended external force with loads CO-TR [kN]	Dynamic load capacity [kN]	Static load capacity [kN]	Maximum recommended external force with loads CO-CO TR-TR [kN]	Maximum recommended external force with loads CO-TR [kN]
	$l/2$	d_0	P_h	D_w	d_2	$i (1e)$	$C_a (kN)$	$C_{oa} (kN)$	F_{max,CO^2TR^2}	$F_{max,CO-TR}$	$C_a (kN)$	$C_{oa} (kN)$	F_{max,CO^2TR^2}	$F_{max,CO-TR}$
TS_(2S)-B 8025-9-4	2	80	25	9,525	72,2	4	225	671	210	210				
TS_(2S)-B 8025-9-5	2	80	25	9,525	72,2	5	263	803	250	250				
TS_(2S)-B 8025-9-6	2	80	25	9,525	72,2	6	312	987	310	300				
TS_(2S)-B 8025-9-7	2	80	25	9,525	72,2	7	360	1171	370	360				
TS_(2S)-B 8025-9-8	2	80	25	9,525	72,2	8	404	1342	420	400				
TS_(2S)-B 8025-9-9	2	80	25	9,525	72,2	9	441	1480	450	430				
TS_(2S)-B 8025-9-10	2	80	25	9,525	72,2	10	485	1658	510	480				
TS_(2S)-B 8025-9-11	2	80	25	9,525	72,2	11	529	1835	550	520				
TS_(2S)-B 8025-9-12	2	80	25	9,525	72,2	12	572	2013	600	560				
TS_(2S)-B 8032-12-2	2	80	32	12,7	71	2	186	419	80	80	204	467	100	100
TS_(2S)-B 8032-12-3	2	80	32	12,7	71	3	262	671	120	120	288	747	160	160
TS_(2S)-B 8032-12-4	2	80	32	12,7	71	4	338	922	160	160	368	1014	220	210
TS_(2S)-B 8032-12-5	2	80	32	12,7	71	5	412	1174	210	200	450	1295	270	270
TS_(2S)-B 8032-12-6	2	80	32	12,7	71	6	485	1425	250	240	530	1575	320	310
TS_(2S)-B 8032-12-7	2	80	32	12,7	71	7	540	1605	280	270	587	1762	380	360
TS_(2S)-B 8032-12-8	2	80	32	12,7	71	8	607	1844	310	300	662	2029	420	400
TS_(2S)-B 8032-12-9	2	80	32	12,7	71	9	679	2108	360	330	740	2322	470	440
TS_(2S)-B 8040-15-2	2	80	40	15,875	67	2	250	515	180	180	274	578	130	130
TS_(2S)-B 8040-15-3	2	80	40	15,875	67	3	357	839	300	290	391	942	220	220
TS_(2S)-B 8040-15-4	2	80	40	15,875	67	4	458	1144	400	390	502	1285	290	290
TS_(2S)-B 8040-15-5	2	80	40	15,875	67	5	561	1468	500	490	616	1649	370	360
TS_(2S)-B 8040-15-6	2	80	40	15,875	67	6	663	1793	600	570	727	2013	440	420
TS_(2S)-B 8040-15-7	2	80	40	15,875	67	7	729	1983	660	620	800	2227	490	450
TS_(2S)-B 8050-19-2	2	80	50	19,05	64,1	2	306	592	250	250	345	686	170	170
TS_(2S)-B 8050-19-3	2	80	50	19,05	64,1	3	438	969	400	390	494	1123	270	270
TS_(2S)-B 8050-19-4	2	80	50	19,05	64,1	4	569	1345	530	510	641	1560	360	350
TS_(2S)-B 8050-19-5	2	80	50	19,05	64,1	5	697	1722	670	640	785	1997	460	430
TS_-B 10012,7-9-2	1	100	12,7	9,525	92,2	2	91	244	80	80				
TS_-B 10012,7-9-3	1	100	12,7	9,525	92,2	3	126	380	120	120				
TS_-B 10012,7-9-4	1	100	12,7	9,525	92,2	4	156	488	160	160				
TS_-B 10012,7-9-5	1	100	12,7	9,525	92,2	5	190	623	200	200				
TS_-B 10012,7-9-6	1	100	12,7	9,525	92,2	6	224	759	240	240				
TS_-B 10012,7-9-7	1	100	12,7	9,525	92,2	7	251	863	280	280				
TS_-B 10012,7-9-8	1	100	12,7	9,525	92,2	8	283	995	320	320				
TS_-B 10012,7-9-9	1	100	12,7	9,525	92,2	9	317	1139	360	360				
TS_-B 10012,7-9-10	1	100	12,7	9,525	92,2	10	344	1247	400	390				

* C_a and C_{oa} : Modified static and dynamic load capacities, calculated according to DIN 69051/4 standard and ISO3408/5. See pages 39 and 43.

** Rb/t : Rigidity of the balls contact zone for an external force 20% of C_a . See page 46. For different forces, multiply by $\sqrt[3]{F/0,2 C_a}$

*** Rnu : Total rigidity of the complete nut. It must be multiplied by the factor f_{ar} , which depends on the manufacturing tolerance. See page 48.

**** Check with SHUTON in case higher loads or more adjusted nut dimensions are required.

***** Check external maximum axial force in the two senses.

For the indicated leads, in case C_a and C_{oa} requirements is lower, there is possibility of smaller size balls

Nut length	Nut dimensions, B-type recirculation, 8 hole design <small>*dimensions of 12 hole design check with Shuton</small>										Grease quantity TS 'steel ball'	Ball screw reference TSB Flanged single nut TSL Cylindrical single nut Recirculation U and B
	TSB	D_1	$D_{L,min}$	D_4	D_6	M	D_5	L_7	L_1	L_8		
142	120		140	160	M12	13,5	35	25	125	142,5	75	TS_(2S)-B 8025-9-4
179	120		140	160	M12	13,5	35	25	125	142,5	103	TS_(2S)-B 8025-9-5
204	120		140	160	M12	13,5	35	25	125	142,5	114	TS_(2S)-B 8025-9-6
229	120		140	160	M12	13,5	35	25	125	142,5	125	TS_(2S)-B 8025-9-7
254	120		140	160	M12	13,5	35	25	125	142,5	138	TS_(2S)-B 8025-9-8
284	120		140	160	M12	13,5	35	25	125	142,5	158	TS_(2S)-B 8025-9-9
309	120		140	160	M12	13,5	35	25	125	142,5	170	TS_(2S)-B 8025-9-10
334	120		143	166	M14	15,5	35	25	125	145,5	180	TS_(2S)-B 8025-9-11
357	120		143	166	M14	15,5	35	25	125	145,5	190	TS_(2S)-B 8025-9-12
109	130		150	170	M12	13,5	40	25	135	152,5	85	TS_(2S)-B 8032-12-2
141	130		150	170	M12	13,5	40	25	135	152,5	104	TS_(2S)-B 8032-12-3
173	130		150	170	M12	13,5	40	25	135	152,5	124	TS_(2S)-B 8032-12-4
205	130		150	170	M12	13,5	40	25	135	152,5	143	TS_(2S)-B 8032-12-5
237	130		150	170	M12	13,5	40	25	135	152,5	164	TS_(2S)-B 8032-12-6
285	130		150	170	M12	13,5	40	25	135	152,5	210	TS_(2S)-B 8032-12-7
317	130		150	170	M12	13,5	40	25	135	152,5	231	TS_(2S)-B 8032-12-8
349	130		150	170	M12	13,5	40	25	135	152,5	249	TS_(2S)-B 8032-12-9
131	140		166	192	M16	17,5	45	25	145	168,5	141	TS_(2S)-B 8040-15-2
171	140		166	192	M16	17,5	45	25	145	168,5	170	TS_(2S)-B 8040-15-3
211	140		166	192	M16	17,5	45	25	145	168,5	203	TS_(2S)-B 8040-15-4
251	140		166	192	M16	17,5	45	25	145	168,5	236	TS_(2S)-B 8040-15-5
291	140		166	192	M16	17,5	45	25	145	168,5	271	TS_(2S)-B 8040-15-6
351	140		166	192	M16	17,5	45	25	145	168,5	352	TS_(2S)-B 8040-15-7
157	150		176	202	M16	17,5	50	40	155	178,5	201	TS_(2S)-B 8050-19-2
207	150		176	202	M16	17,5	50	40	155	178,5	246	TS_(2S)-B 8050-19-3
257	150		176	202	M16	17,5	50	40	155	178,5	297	TS_(2S)-B 8050-19-4
307	150		176	202	M16	17,5	50	40	155	178,5	343	TS_(2S)-B 8050-19-5
65	140		166	192	M16	17,5	35	25	145	168,5	47	TS_-B 10012,7-9-2
78	140		166	192	M16	17,5	35	25	145	168,5	54	TS_-B 10012,7-9-3
97	140		166	192	M16	17,5	35	25	145	168,5	71	TS_-B 10012,7-9-4
110	140		166	192	M16	17,5	35	25	145	168,5	79	TS_-B 10012,7-9-5
123	140		166	192	M16	17,5	35	25	145	168,5	87	TS_-B 10012,7-9-6
137	140		166	192	M16	17,5	35	25	145	168,5	97	TS_-B 10012,7-9-7
150	140		166	192	M16	17,5	35	25	145	168,5	105	TS_-B 10012,7-9-8
163	140		166	192	M16	17,5	35	25	145	168,5	112	TS_-B 10012,7-9-9
177	140		166	192	M16	17,5	35	25	145	168,5	123	TS_-B 10012,7-9-10

Key dimensions of the cylindrical nut: N, M, Y are obtained in the tables of page 38 of the catalogue.

SHUTON advises to use the dimensions of the tables, although it is possible to manufacture ball screw with other dimensions. In brackets () second options. Smaller nut diameters than the first option of the table can reduce the rigidity of the assembly between 5 and 10%.

Please consult SHUTON.

HIGH LOADS, Single nut

Ball screw reference TSB Flanged single nut TSL Cylindrical single nut Recirculation U and B	No. Starts	Nominal diameter	Lead	Ball diameter	Root diameter	Circuits	IML Type				HDL Type				
							Dynamic load capacity [kN]	Static load capacity [kN]	Maximum recommended external force with loads CO-CO TR-TR [kN]	Maximum recommended external force with loads CO-TR [kN]	Dynamic load capacity [kN]	Static load capacity [kN]	Maximum recommended external force with loads CO-CO TR-TR [kN]	Maximum recommended external force with loads CO-TR [kN]	
							C_a (kN)	C_{oa} (kN)	F_{max,CO^2TR^2}	$F_{max,CO-TR}$	C_a (kN)	C_{oa} (kN)	F_{max,CO^2TR^2}	$F_{max,CO-TR}$	
	$l/2$	d_0	P_h	D_w	d_2	i (1e)									
TS_-B 10012,7-9-11	1	100	12,7	9,525	92,2	11	373	1375	430	430					
TS_-B 10012,7-9-12	1	100	12,7	9,525	92,2	12	406	1518	480	470					
TS_-B 10012,7-9-13	1	100	12,7	9,525	92,2	13	430	1618	510	500					
TS_-B 10012,7-9-14	1	100	12,7	9,525	92,2	14	461	1758	550	540					
TS_-B 10012,7-9-15	1	100	12,7	9,525	92,2	15	491	1898	590	570					
TS_-B 10016-12-2	1	100	16	12,7	91	2	136	329	60	60	150	367	80	80	
TS_-B 10016-12-3	1	100	16	12,7	91	3	190	519	95	95	207	570	120	120	
TS_-B 10016-12-4	1	100	16	12,7	91	4	245	709	130	130	267	782	170	170	
TS_-B 10016-12-5	1	100	16	12,7	91	5	286	848	160	160	311	929	200	200	
TS_-B 10016-12-6	1	100	16	12,7	91	6	338	1038	190	190	369	1141	250	250	
TS_-B 10016-12-7	1	100	16	12,7	91	7	390	1228	220	220	425	1353	290	290	
TS_-B 10016-12-8	1	100	16	12,7	91	8	440	1418	250	250	480	1565	330	330	
TS_-B 10016-12-9	1	100	16	12,7	91	9	478	1556	280	280	521	1711	370	370	
TS_-B 10016-12-10	1	100	16	12,7	91	10	524	1732	310	300	576	1931	410	400	
TS_-B 10016-12-11	1	100	16	12,7	91	11	574	1929	340	330	626	2127	450	440	
TS_-B 10016-12-12	1	100	16	12,7	91	12	622	2126	380	360	680	2347	500	480	
TS_-B 10016-12-13	1	100	16	12,7	91	13	656	2251	400	380	715	2477	520	500	
TS_-B 10016-12-14	1	100	16	12,7	91	14	705	2455	430	410	770	2705	570	550	
TS_-B 10016-12-15	1	100	16	12,7	91	15	749	2631	460	440	817	2901	600	580	
TS_-B 10016-12-16	1	100	16	12,7	91	16	797	2835	490	460	870	3129	650	610	
TS_-B 10016-12-17	1	100	16	12,7	91	17	829	2959	520	480	905	3259	680	640	
TS_-B 10016-12-18	1	100	16	12,7	91	18	873	3142	540	500	952	3463	710	660	
TS_-B 10016-12-19	1	100	16	12,7	91	19	916	3325	570	530	1000	3667	750	690	
TS_-B 10016-12-20	1	100	16	12,7	91	20	965	3544	600	550	1054	3911	790	720	
TS_-B 10020-15-2	1	100	20	15,875	87	2	184	398	140	140	201	447	100	100	
TS_-B 10020-15-3	1	100	20	15,875	87	3	261	645	230	230	286	724	170	170	
TS_-B 10020-15-4	1	100	20	15,875	87	4	335	879	310	310	367	987	230	230	
TS_-B 10020-15-5	1	100	20	15,875	87	5	410	1125	390	390	449	1263	290	290	
TS_-B 10020-15-6	1	100	20	15,875	87	6	463	1289	450	450	508	1447	330	330	
TS_-B 10020-15-7	1	100	20	15,875	87	7	533	1523	540	530	584	1710	390	390	
TS_-B 10020-15-8	1	100	20	15,875	87	8	601	1758	610	600	659	1973	450	440	
TS_-B 10020-15-9	1	100	20	15,875	87	9	674	2016	690	670	738	2263	510	490	
TS_-B 10020-15-10	1	100	20	15,875	87	10	739	2250	770	740	810	2526	560	550	
TS_-B 10020-15-11	1	100	20	15,875	87	11	792	2426	830	800	868	2723	610	590	
TS_-B 10020-15-12	1	100	20	15,875	87	12	851	2637	890	850	933	2960	650	620	
TS_-B 10020-15-13	1	100	20	15,875	87	13	917	2883	970	920	1005	3236	720	680	

* C_a and C_{oa} : Modified static and dynamic load capacities, calculated according to DIN 69051/4 standard and ISO3408/5. See pages 39 and 43.

** Rb/t : Rigidity of the balls contact zone for an external force 20% of C_a . See page 46. For different forces, multiply by $\sqrt[3]{F/0,2 C_a}$

*** Rnu : Total rigidity of the complete nut. It must be multiplied by the factor f_{an} , which depends on the manufacturing tolerance. See page 48.

**** Check with SHUTON in case higher loads or more adjusted nut dimensions are required.

***** Check external maximum axial force in the two senses.

For the indicated leads, in case C_a and C_{oa} requirements is lower, there is possibility of smaller size balls

Nut length	Nut dimensions, B-type recirculation, 8 hole design <small>*dimensions of 12 hole design check with Shuton</small>										Grease quantity TS 'steel ball'	Ball screw reference TSB Flanged single nut TSL Cylindrical single nut Recirculation U and B
	TSB	D_1	$D_{1,min}$	D_4	D_6	M	D_5	L_7	L_1	L_8		
189	140		166	192	M16	17,5	35	25	145	168,5	129	TS_-B 10012,7-9-11
202	140		166	192	M16	17,5	35	25	145	168,5	137	TS_-B 10012,7-9-12
215	140		166	192	M16	17,5	35	25	145	168,5	146	TS_-B 10012,7-9-13
228	140		166	192	M16	17,5	35	25	145	168,5	153	TS_-B 10012,7-9-14
241	140		166	192	M16	17,5	35	25	145	168,5	161	TS_-B 10012,7-9-15
75	155	(150)	181 (176)	207 (202)	M16	17,5	40	25	160 (155)	183,5 (178,5)	76	TS_-B 10016-12-2
91	155	(150)	181 (176)	207 (202)	M16	17,5	40	25	160 (155)	183,5 (178,5)	87	TS_-B 10016-12-3
107	155	(150)	181 (176)	207 (202)	M16	17,5	40	25	160 (155)	183,5 (178,5)	99	TS_-B 10016-12-4
131	155	(150)	181 (176)	207 (202)	M16	17,5	40	25	160 (155)	183,5 (178,5)	127	TS_-B 10016-12-5
147	155	(150)	181 (176)	207 (202)	M16	17,5	40	25	160 (155)	183,5 (178,5)	139	TS_-B 10016-12-6
163	155	(150)	181 (176)	207 (202)	M16	17,5	40	25	160 (155)	183,5 (178,5)	152	TS_-B 10016-12-7
179	155	(150)	181 (176)	207 (202)	M16	17,5	40	25	160 (155)	183,5 (178,5)	163	TS_-B 10016-12-8
198	155	(150)	181 (176)	207 (202)	M16	17,5	40	25	160 (155)	183,5 (178,5)	182	TS_-B 10016-12-9
214	155	(150)	181 (176)	207 (202)	M16	17,5	40	25	160 (155)	183,5 (178,5)	196	TS_-B 10016-12-10
230	155	(150)	181 (176)	207 (202)	M16	17,5	40	25	160 (155)	183,5 (178,5)	208	TS_-B 10016-12-11
246	155	(150)	181 (176)	207 (202)	M16	17,5	40	25	160 (155)	183,5 (178,5)	219	TS_-B 10016-12-12
263	155	(150)	181 (176)	207 (202)	M16	17,5	40	25	160 (155)	183,5 (178,5)	237	TS_-B 10016-12-13
279	155	(150)	181 (176)	207 (202)	M16	17,5	40	25	160 (155)	183,5 (178,5)	248	TS_-B 10016-12-14
295	155	(150)	181 (176)	207 (202)	M16	17,5	40	25	160 (155)	183,5 (178,5)	260	TS_-B 10016-12-15
311	155	(150)	181 (176)	207 (202)	M16	17,5	40	25	160 (155)	183,5 (178,5)	271	TS_-B 10016-12-16
328	155	(150)	181 (176)	207 (202)	M16	17,5	40	25	160 (155)	183,5 (178,5)	288	TS_-B 10016-12-17
344	155	(150)	181 (176)	207 (202)	M16	17,5	40	25	160 (155)	183,5 (178,5)	302	TS_-B 10016-12-18
358	155	(150)	181 (176)	207 (202)	M16	17,5	40	25	160 (155)	183,5 (178,5)	309	TS_-B 10016-12-19
374	155	(150)	181 (176)	207 (202)	M16	17,5	40	25	160 (155)	183,5 (178,5)	320	TS_-B 10016-12-20
89	165	(160)	191 (186)	217 (212)	M16	17,5	45	40	170 (165)	193,5 (188,5)	123	TS_-B 10020-15-2
109	165	(160)	191 (186)	217 (212)	M16	17,5	45	40	170 (165)	193,5 (188,5)	142	TS_-B 10020-15-3
129	165	(160)	191 (186)	217 (212)	M16	17,5	45	40	170 (165)	193,5 (188,5)	163	TS_-B 10020-15-4
149	165	(160)	191 (186)	217 (212)	M16	17,5	45	40	170 (165)	193,5 (188,5)	182	TS_-B 10020-15-5
179	165	(160)	191 (186)	217 (212)	M16	17,5	45	40	170 (165)	193,5 (188,5)	231	TS_-B 10020-15-6
199	165	(160)	191 (186)	217 (212)	M16	17,5	45	40	170 (165)	193,5 (188,5)	249	TS_-B 10020-15-7
219	165	(160)	191 (186)	217 (212)	M16	17,5	45	40	170 (165)	193,5 (188,5)	273	TS_-B 10020-15-8
239	165	(160)	191 (186)	217 (212)	M16	17,5	45	40	170 (165)	193,5 (188,5)	291	TS_-B 10020-15-9
259	165	(160)	191 (186)	217 (212)	M16	17,5	45	40	170 (165)	193,5 (188,5)	312	TS_-B 10020-15-10
283	165	(160)	191 (186)	217 (212)	M16	17,5	45	40	170 (165)	193,5 (188,5)	344	TS_-B 10020-15-11
303	165	(160)	191 (186)	217 (212)	M16	17,5	45	40	170 (165)	193,5 (188,5)	369	TS_-B 10020-15-12
323	165	(160)	191 (186)	217 (212)	M16	17,5	45	40	170 (165)	193,5 (188,5)	386	TS_-B 10020-15-13

Key dimensions of the cylindrical nut: N, M, Y are obtained in the tables of page 38 of the catalogue.

SHUTON advises to use the dimensions of the tables, although it is possible to manufacture ball screw with other dimensions. In brackets () second options. Smaller nut diameters than the first option of the table can reduce the rigidity of the assembly between 5 and 10%.

Please consult SHUTON.

HIGH LOADS, Single nut

Ball screw reference TSB Flanged single nut TSL Cylindrical single nut Recirculation U and B	No. Starts	Nominal diameter	Lead	Ball diameter	Root diameter	Circuits	IML Type				HDL Type			
							Dynamic load capacity [kN]	Static load capacity [kN]	Maximum recommended external force with loads CO-CO TR-TR [kN]	Maximum recommended external force with loads CO-TR [kN]	Dynamic load capacity [kN]	Static load capacity [kN]	Maximum recommended external force with loads CO-CO TR-TR [kN]	Maximum recommended external force with loads CO-TR [kN]
	$l/2$	d_0	P_h	D_w	d_2	$i (I_e)$	$C_a (kN)$	$C_{oa} (kN)$	F_{max,CO^2TR^2}	$F_{max,CO-TR}$	$C_a (kN)$	$C_{oa} (kN)$	F_{max,CO^2TR^2}	$F_{max,CO-TR}$
TS_-B 10020-15-14	1	100	20	15,875	87	14	983	3129	1050	970	1077	3513	770	720
TS_-B 10020-15-15	1	100	20	15,875	87	15	1047	3375	1100	1000	1148	3789	820	760
TS_-B 10020-15-16	1	100	20	15,875	87	16	1090	3516	1150	1050	1194	3947	840	770
TS_-B 10020-15-17	1	100	20	15,875	87	17	1160	3797	1250	1100	1272	4262	910	820
TS_-B 10020-15-18	1	100	20	15,875	87	18	1221	4031	1300	1150	1338	4526	950	840
TS_-B 10020-15-19	1	100	20	15,875	87	19	1281	4266	1350	1200	1404	4789	990	870
TS_-B 10020-15-20	1	100	20	15,875	87	20	1341	4500	1400	1200	1470	5052	1050	880
TS_-B 10025-19-2	1	100	25	19,05	84,1	2	231	467	190	190	259	541	130	130
TS_-B 10025-19-3	1	100	25	19,05	84,1	3	326	750	310	310	367	870	210	210
TS_-B 10025-19-4	1	100	25	19,05	84,1	4	421	1034	420	410	474	1198	280	280
TS_-B 10025-19-5	1	100	25	19,05	84,1	5	514	1317	530	520	578	1527	360	350
TS_-B 10025-19-6	1	100	25	19,05	84,1	6	605	1600	630	620	680	1855	430	420
TS_-B 10025-19-7	1	100	25	19,05	84,1	7	694	1884	720	700	780	2184	490	480
TS_-B 10025-19-8	1	100	25	19,05	84,1	8	757	2067	820	790	851	2396	550	540
TS_-B 10025-19-9	1	100	25	19,05	84,1	9	847	2367	920	890	953	2744	630	600
TS_-B 10025-19-10	1	100	25	19,05	84,1	10	928	2634	1000	960	1044	3053	690	650
TS_-B 10025-19-11	1	100	25	19,05	84,1	11	1015	2934	1100	1050	1142	3401	760	710
TS_-B 10025-19-12	1	100	25	19,05	84,1	12	1094	3201	1200	1100	1231	3710	820	760
TS_-B 10025-19-13	1	100	25	19,05	84,1	13	1179	3501	1300	1150	1327	4058	870	790
TS_-B 10025-19-14	1	100	25	19,05	84,1	14	1256	3768	1350	1200	1413	4367	910	820
TS_-B 10025-19-15	1	100	25	19,05	84,1	15	1314	3951	1450	1250	1478	4580	980	860
TS_-B 10025-19-16	1	100	25	19,05	84,1	16	1397	4251	1500	1300	1571	4928	1050	880
TS_-B 10032-25-3	1	100	32	25,4	78,6	3					528	1136	240	240
TS_-B 10032-25-4	1	100	32	25,4	78,6	4					691	1598	340	330
TS_-B 10032-25-5	1	100	32	25,4	78,6	5					850	2059	430	420
TS_-B 10032-25-6	1	100	32	25,4	78,6	6					1006	2521	510	490
TS_-B 10032-25-7	1	100	32	25,4	78,6	7					1157	2982	580	560
TS_-B 10032-25-8	1	100	32	25,4	78,6	8					1243	3195	660	620
TS_-B 10032-25-9	1	100	32	25,4	78,6	9					1399	3692	740	690
TS_-B 10032-25-10	1	100	32	25,4	78,6	10					1535	4118	800	730
TS_-B 10032-25-11	1	100	32	25,4	78,6	11					1687	4615	880	790
TS_-B 10032-25-12	1	100	32	25,4	78,6	12					1819	5041	940	810
TS_(2S)-B 10025-9-2	2	100	25	9,525	92,2	2	141	405	130	130				
TS_(2S)-B 10025-9-3	2	100	25	9,525	92,2	3	195	631	200	200				
TS_(2S)-B 10025-9-4	2	100	25	9,525	92,2	4	241	811	260	260				
TS_(2S)-B 10025-9-5	2	100	25	9,525	92,2	5	294	1037	330	320				

* C_a and C_{oa} : Modified static and dynamic load capacities, calculated according to DIN 69051/4 standard and ISO3408/5. See pages 39 and 43.

** R_b/t : Rigidity of the balls contact zone for an external force 20% of C_a . See page 46. For different forces, multiply by $\sqrt[3]{F/0,2 C_a}$

*** R_{nu} : Total rigidity of the complete nut. It must be multiplied by the factor f_{an} , which depends on the manufacturing tolerance. See page 48.

**** Check with SHUTON in case higher loads or more adjusted nut dimensions are required.

***** Check external maximum axial force in the two senses.

For the indicated leads, in case C_a and C_{oa} requirements is lower, there is possibility of smaller size balls

Nut length	Nut dimensions, B-type recirculation, 8 hole design <small>*dimensions of 12 hole design check with Shuton</small>										Grease quantity TS 'steel ball'	Ball screw reference TSB Flanged single nut TSL Cylindrical single nut Recirculation U and B
	TSB	D_1	$D_{L,min}$	D_4	D_6	M	D_5	L_7	L_1	L_8		
343	165	(160)	194 (189)	223 (218)	M18	20	45	40	170 (165)	196,5 (191,5)	406	TS_-B 10020-15-14
361	165	(160)	194 (189)	223 (218)	M18	20	45	40	170 (165)	196,5 (191,5)	423	TS_-B 10020-15-15
382	165	(160)	194 (189)	223 (218)	M18	20	45	40	170 (165)	196,5 (191,5)	454	TS_-B 10020-15-16
402	165	(160)	197 (192)	229 (224)	M20	22	45	40	170 (165)	199,5 (194,5)	466	TS_-B 10020-15-17
422	165	(160)	197 (192)	229 (224)	M20	22	45	40	170 (165)	199,5 (194,5)	490	TS_-B 10020-15-18
442	165	(160)	197 (192)	229 (224)	M20	22	45	40	170 (165)	199,5 (194,5)	508	TS_-B 10020-15-19
462	165	(160)	197 (192)	229 (224)	M20	22	45	40	170 (165)	199,5 (194,5)	531	TS_-B 10020-15-20
105	175	(170)	201 (196)	227 (222)	M16	17,5	50	40	180 (175)	203,5 (198,5)	174	TS_-B 10025-19-2
130	175	(170)	201 (196)	227 (222)	M16	17,5	50	40	180 (175)	203,5 (198,5)	202	TS_-B 10025-19-3
155	175	(170)	201 (196)	227 (222)	M16	17,5	50	40	180 (175)	203,5 (198,5)	233	TS_-B 10025-19-4
180	175	(170)	201 (196)	227 (222)	M16	17,5	50	40	180 (175)	203,5 (198,5)	263	TS_-B 10025-19-5
205	175	(170)	201 (196)	227 (222)	M16	17,5	50	40	180 (175)	203,5 (198,5)	294	TS_-B 10025-19-6
230	175	(170)	201 (196)	227 (222)	M16	17,5	50	40	180 (175)	203,5 (198,5)	329	TS_-B 10025-19-7
268	175	(170)	201 (196)	227 (222)	M16	17,5	50	40	180 (175)	203,5 (198,5)	396	TS_-B 10025-19-8
293	175	(170)	201 (196)	227 (222)	M16	17,5	50	40	180 (175)	203,5 (198,5)	424	TS_-B 10025-19-9
318	175	(170)	204 (199)	233 (228)	M18	20	50	40	180 (175)	206,5 (201,5)	457	TS_-B 10025-19-10
343	175	(170)	204 (199)	233 (228)	M18	20	50	40	180 (175)	206,5 (201,5)	485	TS_-B 10025-19-11
366	175	(170)	207 (202)	239 (234)	M20	22	50	40	180 (175)	209,5 (204,5)	513	TS_-B 10025-19-12
391	175	(170)	207 (202)	239 (234)	M20	22	50	40	180 (175)	209,5 (204,5)	545	TS_-B 10025-19-13
416	175	(170)	207 (202)	239 (234)	M20	22	50	40	180 (175)	209,5 (204,5)	583	TS_-B 10025-19-14
445	175	(170)	207 (202)	239 (234)	M20	22	50	40	180 (175)	209,5 (204,5)	622	TS_-B 10025-19-15
470	175	(170)	207 (202)	239 (234)	M20	22	50	40	180 (175)	209,5 (204,5)	652	TS_-B 10025-19-16
162	190		223	255	M20	22	60	40	195	225	367	TS_-B 10032-25-3
194	190		223	255	M20	22	60	40	195	225	417	TS_-B 10032-25-4
226	190		223	255	M20	22	60	40	195	225	472	TS_-B 10032-25-5
258	190		223	255	M20	22	60	40	195	225	527	TS_-B 10032-25-6
290	190		223	255	M20	22	60	40	195	225	588	TS_-B 10032-25-7
338	190		223	255	M20	22	60	40	195	225	708	TS_-B 10032-25-8
370	190		223	255	M20	22	60	40	195	225	757	TS_-B 10032-25-9
400	190		223	255	M20	22	60	40	195	225	811	TS_-B 10032-25-10
432	190		223	255	M20	22	60	40	195	225	860	TS_-B 10032-25-11
464	190		226	261	M22	24	60	40	195	228	921	TS_-B 10032-25-12
92	140		166	192	M16	17,5	35	25	145	168,5	63	TS_(2S)-B 10025-9-2
117	140		166	192	M16	17,5	35	25	145	168,5	78	TS_(2S)-B 10025-9-3
154	140		166	192	M16	17,5	35	25	145	168,5	111	TS_(2S)-B 10025-9-4
179	140		166	192	M16	17,5	35	25	145	168,5	126	TS_(2S)-B 10025-9-5

Key dimensions of the cylindrical nut: N, M, Y are obtained in the tables of page 38 of the catalogue.

SHUTON advises to use the dimensions of the tables, although it is possible to manufacture ball screw with other dimensions. In brackets () second options. Smaller nut diameters than the first option of the table can reduce the rigidity of the assembly between 5 and 10%.

Please consult SHUTON.

HIGH LOADS, Single nut

Ball screw reference TSB Flanged single nut TSL Cylindrical single nut Recirculation U and B	No. Starts	Nominal diameter	Lead	Ball diameter	Root diameter	Circuits	IML Type				HDL Type					
							Dynamic load capacity [kN]	Static load capacity [kN]	Maximum recommended external force with loads CO-CO TR-TR [kN]	Maximum recommended external force with loads CO-TR [kN]	Dynamic load capacity [kN]	Static load capacity [kN]	Maximum recommended external force with loads CO-CO TR-TR [kN]	Maximum recommended external force with loads CO-TR [kN]		
							C_a (kN)	C_{oa} (kN)	F_{max,CO^2TR^2}	$F_{max,CO-TR}$	C_a (kN)	C_{oa} (kN)	F_{max,CO^2TR^2}	$F_{max,CO-TR}$		
	$l/2$	d_0	P_h	D_w	d_2	i (1e)										
TS_(2S)-B 10025-9-6	2	100	25	9,525	92,2	6	347	1263	400	390						
TS_(2S)-B 10025-9-7	2	100	25	9,525	92,2	7	389	1435	450	440						
TS_(2S)-B 10025-9-8	2	100	25	9,525	92,2	8	438	1655	520	500						
TS_(2S)-B 10025-9-9	2	100	25	9,525	92,2	9	490	1894	580	560						
TS_(2S)-B 10025-9-10	2	100	25	9,525	92,2	10	531	2073	640	610						
TS_(2S)-B 10025-9-11	2	100	25	9,525	92,2	11	578	2286	700	660						
TS_(2S)-B 10025-9-12	2	100	25	9,525	92,2	12	628	2525	760	700						
TS_(2S)-B 10032-12-2	2	100	32	12,7	91	2	211	546	100	100	232	609	130	130		
TS_(2S)-B 10032-12-3	2	100	32	12,7	91	3	294	862	160	160	320	947	210	210		
TS_(2S)-B 10032-12-4	2	100	32	12,7	91	4	378	1177	210	210	412	1299	280	270		
TS_(2S)-B 10032-12-5	2	100	32	12,7	91	5	442	1408	260	250	486	1570	340	340		
TS_(2S)-B 10032-12-6	2	100	32	12,7	91	6	523	1723	310	300	569	1894	400	390		
TS_(2S)-B 10032-12-7	2	100	32	12,7	91	7	602	2039	360	340	656	2246	470	450		
TS_(2S)-B 10032-12-8	2	100	32	12,7	91	8	679	2354	410	380	741	2598	530	500		
TS_(2S)-B 10032-12-9	2	100	32	12,7	91	9	739	2585	450	420	805	2842	580	540		
TS_(2S)-B 10032-12-10	2	100	32	12,7	91	10	816	2912	490	450	890	3207	650	590		
TS_(2S)-B 10032-12-11	2	100	32	12,7	91	11	886	3204	530	470	966	3532	700	620		
TS_(2S)-B 10032-12-12	2	100	32	12,7	91	12	961	3531	570	490	1049	3897	760	660		
TS_(2S)-B 10032-12-13	2	100	32	12,7	91	13	1022	3786	610	510	1114	4168	800	670		
TS_(2S)-B 10040-15-2	2	100	40	15,875	87	2	288	680	240	240	316	763	180	180		
TS_(2S)-B 10040-15-3	2	100	40	15,875	87	3	402	1068	370	370	440	1199	270	270		
TS_(2S)-B 10040-15-4	2	100	40	15,875	87	4	520	1476	510	500	570	1657	370	370		
TS_(2S)-B 10040-15-5	2	100	40	15,875	87	5	631	1864	630	610	691	2093	470	450		
TS_(2S)-B 10040-15-6	2	100	40	15,875	87	6	714	2136	730	690	782	2398	530	510		
TS_(2S)-B 10040-15-7	2	100	40	15,875	87	7	829	2564	870	810	909	2878	640	600		
TS_(2S)-B 10040-15-8	2	100	40	15,875	87	8	934	2952	960	880	1024	3314	710	640		
TS_(2S)-B 10040-15-9	2	100	40	15,875	87	9	1037	3340	1050	940	1137	3750	780	690		
TS_(2S)-B 10040-15-10	2	100	40	15,875	87	10	1139	3729	1150	990	1248	4186	850	730		
TS_(2S)-B 10050-19-2	2	100	50	19,05	84,1	2	354	771	310	310	398	894	210	210		
TS_(2S)-B 10050-19-3	2	100	50	19,05	84,1	3	500	1239	500	490	562	1437	340	330		
TS_(2S)-B 10050-19-4	2	100	50	19,05	84,1	4	653	1735	680	660	734	2011	470	450		
TS_(2S)-B 10050-19-5	2	100	50	19,05	84,1	5	795	2203	840	800	894	2554	570	540		
TS_(2S)-B 10050-19-6	2	100	50	19,05	84,1	6	889	2479	950	880	1000	2873	650	600		
TS_(2S)-B 10050-19-7	2	100	50	19,05	84,1	7	1033	2975	1100	990	1161	3448	750	670		
TS_(2S)-B 10050-19-8	2	100	50	19,05	84,1	8	1173	3470	1250	1050	1320	4023	850	730		
TS_-B 12012,7-9-2	1	120	12,7	9,525	112,2	2	99	297	95	95						

* C_a and C_{oa} : Modified static and dynamic load capacities, calculated according to DIN 69051/4 standard and ISO3408/5. See pages 39 and 43.

** Rb/t : Rigidity of the balls contact zone for an external force 20% of C_a . See page 46. For different forces, multiply by $\sqrt[3]{F/0,2 C_a}$

*** Rnu : Total rigidity of the complete nut. It must be multiplied by the factor f_{an} , which depends on the manufacturing tolerance. See page 48.

**** Check with SHUTON in case higher loads or more adjusted nut dimensions are required.

***** Check external maximum axial force in the two senses.

For the indicated leads, in case C_a and C_{oa} requirements is lower, there is possibility of smaller size balls

Nut length	Nut dimensions, B-type recirculation, 8 hole design <small>*dimensions of 12 hole design check with Shuton</small>										Grease quantity TS 'steel ball'	Ball screw reference TSB Flanged single nut TSL Cylindrical single nut Recirculation U and B
	TSB	D_1	$D_{L,min}$	D_4	D_6	M	D_5	L_7	L_1	L_8		
204	140		166	192	M16	17,5	35	25	145	168,5	140	TS_(2S)-B 10025-9-6
234	140		166	192	M16	17,5	35	25	145	168,5	164	TS_(2S)-B 10025-9-7
259	140		166	192	M16	17,5	35	25	145	168,5	179	TS_(2S)-B 10025-9-8
284	140		166	192	M16	17,5	35	25	145	168,5	192	TS_(2S)-B 10025-9-9
311	140		166	192	M16	17,5	35	25	145	168,5	213	TS_(2S)-B 10025-9-10
336	140		166	192	M16	17,5	35	25	145	168,5	227	TS_(2S)-B 10025-9-11
359	140		166	192	M16	17,5	35	25	145	168,5	238	TS_(2S)-B 10025-9-12
109	155	(150)	181 (176)	207 (202)	M16	17,5	40	25	160 (155)	183,5 (178,5)	103	TS_(2S)-B 10032-12-2
141	155	(150)	181 (176)	207 (202)	M16	17,5	40	25	160 (155)	183,5 (178,5)	125	TS_(2S)-B 10032-12-3
173	155	(150)	181 (176)	207 (202)	M16	17,5	40	25	160 (155)	183,5 (178,5)	150	TS_(2S)-B 10032-12-4
221	155	(150)	181 (176)	207 (202)	M16	17,5	40	25	160 (155)	183,5 (178,5)	207	TS_(2S)-B 10032-12-5
253	155	(150)	181 (176)	207 (202)	M16	17,5	40	25	160 (155)	183,5 (178,5)	230	TS_(2S)-B 10032-12-6
285	155	(150)	181 (176)	207 (202)	M16	17,5	40	25	160 (155)	183,5 (178,5)	256	TS_(2S)-B 10032-12-7
317	155	(150)	181 (176)	207 (202)	M16	17,5	40	25	160 (155)	183,5 (178,5)	280	TS_(2S)-B 10032-12-8
355	155	(150)	181 (176)	207 (202)	M16	17,5	40	25	160 (155)	183,5 (178,5)	318	TS_(2S)-B 10032-12-9
385	155	(150)	181 (176)	207 (202)	M16	17,5	40	25	160 (155)	183,5 (178,5)	337	TS_(2S)-B 10032-12-10
417	155	(150)	181 (176)	207 (202)	M16	17,5	40	25	160 (155)	183,5 (178,5)	365	TS_(2S)-B 10032-12-11
449	155	(150)	181 (176)	207 (202)	M16	17,5	40	25	160 (155)	183,5 (178,5)	388	TS_(2S)-B 10032-12-12
483	155	(150)	181 (176)	207 (202)	M16	17,5	40	25	160 (155)	183,5 (178,5)	418	TS_(2S)-B 10032-12-13
131	165	(160)	191 (186)	217 (212)	M16	17,5	45	40	170 (165)	193,5 (188,5)	168	TS_(2S)-B 10040-15-2
171	165	(160)	191 (186)	217 (212)	M16	17,5	45	40	170 (165)	193,5 (188,5)	210	TS_(2S)-B 10040-15-3
211	165	(160)	191 (186)	217 (212)	M16	17,5	45	40	170 (165)	193,5 (188,5)	249	TS_(2S)-B 10040-15-4
251	165	(160)	191 (186)	217 (212)	M16	17,5	45	40	170 (165)	193,5 (188,5)	291	TS_(2S)-B 10040-15-5
311	165	(160)	191 (186)	217 (212)	M16	17,5	45	40	170 (165)	193,5 (188,5)	390	TS_(2S)-B 10040-15-6
351	165	(160)	191 (186)	217 (212)	M16	17,5	45	40	170 (165)	193,5 (188,5)	420	TS_(2S)-B 10040-15-7
389	165	(160)	191 (186)	217 (212)	M16	17,5	45	40	170 (165)	193,5 (188,5)	463	TS_(2S)-B 10040-15-8
429	165	(160)	194 (189)	223 (218)	M18	20	45	40	170 (165)	196,5 (191,5)	505	TS_(2S)-B 10040-15-9
469	165	(160)	194 (189)	223 (218)	M18	20	45	40	170 (165)	196,5 (191,5)	547	TS_(2S)-B 10040-15-10
157	175	(170)	201 (196)	227 (222)	M16	17,5	50	40	180 (175)	203,5 (198,5)	247	TS_(2S)-B 10050-19-2
207	175	(170)	201 (196)	227 (222)	M16	17,5	50	40	180 (175)	203,5 (198,5)	304	TS_(2S)-B 10050-19-3
257	175	(170)	201 (196)	227 (222)	M16	17,5	50	40	180 (175)	203,5 (198,5)	361	TS_(2S)-B 10050-19-4
307	175	(170)	201 (196)	227 (222)	M16	17,5	50	40	180 (175)	203,5 (198,5)	422	TS_(2S)-B 10050-19-5
380	175	(170)	201 (196)	227 (222)	M16	17,5	50	40	180 (175)	203,5 (198,5)	565	TS_(2S)-B 10050-19-6
430	175	(170)	204 (199)	233 (228)	M18	20	50	40	180 (175)	206,5 (201,5)	622	TS_(2S)-B 10050-19-7
480	175	(170)	207 (202)	239 (234)	M20	22	50	40	180 (175)	209,5 (204,5)	679	TS_(2S)-B 10050-19-8
65	160		186	212	M16	17,5	35	25	165	188,5	56	TS_-B 12012,7-9-2

Key dimensions of the cylindrical nut: N, M, Y are obtained in the tables of page 38 of the catalogue.

SHUTON advises to use the dimensions of the tables, although it is possible to manufacture ball screw with other dimensions. In brackets () second options. Smaller nut diameters than the first option of the table can reduce the rigidity of the assembly between 5 and 10%.

Please consult SHUTON.

HIGH LOADS, Single nut

Ball screw reference TSB Flanged single nut TSL Cylindrical single nut Recirculation U and B	No. Starts	Nominal diameter	Lead	Ball diameter	Root diameter	Circuits	IML Type				HDL Type			
							Dynamic load capacity [kN]	Static load capacity [kN]	Maximum recommended external force with loads CO-CO TR-TR [kN]	Maximum recommended external force with loads CO-TR [kN]	Dynamic load capacity [kN]	Static load capacity [kN]	Maximum recommended external force with loads CO-CO TR-TR [kN]	Maximum recommended external force with loads CO-TR [kN]
							C_a (kN)	C_{oa} (kN)	F_{max,CO^2TR^2}	$F_{max,CO-TR}$	C_a (kN)	C_{oa} (kN)	F_{max,CO^2TR^2}	$F_{max,CO-TR}$
	$l/2$	d_0	P_h	D_w	d_2	i (1e)								
TS_(2S)-B 14032-12-2	2	140	32	12,7	131	2	249	800	140	140	271	879	190	190
TS_(2S)-B 14032-12-3	2	140	32	12,7	131	3	344	1244	230	220	376	1374	300	300
TS_(2S)-B 14032-12-4	2	140	32	12,7	131	4	438	1674	300	290	479	1854	390	390
TS_(2S)-B 14032-12-5	2	140	32	12,7	131	5	519	2044	360	360	566	2253	480	470
TS_(2S)-B 14032-12-6	2	140	32	12,7	131	6	612	2487	440	430	668	2747	580	560
TS_(2S)-B 14032-12-7	2	140	32	12,7	131	7	698	2906	510	490	768	3241	670	640
TS_(2S)-B 14032-12-8	2	140	32	12,7	131	8	787	3349	570	540	861	3708	760	720
TS_(2S)-B 14032-12-9	2	140	32	12,7	131	9	864	3731	640	590	944	4120	840	780
TS_(2S)-B 14032-12-10	2	140	32	12,7	131	10	951	4174	700	640	1039	4615	920	840
TS_(2S)-B 14032-12-11	2	140	32	12,7	131	11	1030	4580	750	670	1132	5109	1000	900
TS_(2S)-B 14032-12-12	2	140	32	12,7	131	12	1114	5023	810	700	1219	5563	1050	930
TS_(2S)-B 14032-12-13	2	140	32	12,7	131	13	1189	5417	860	720	1300	5988	1150	960
TS_(2S)-B 14040-15-2	2	140	40	15,875	127	2	342	990	350	350	375	1112	260	260
TS_(2S)-B 14040-15-3	2	140	40	15,875	127	3	478	1565	550	540	524	1756	400	400
TS_(2S)-B 14040-15-4	2	140	40	15,875	127	4	611	2119	730	710	669	2379	540	520
TS_(2S)-B 14040-15-5	2	140	40	15,875	127	5	722	2575	890	860	791	2890	650	630
TS_(2S)-B 14040-15-6	2	140	40	15,875	127	6	850	3129	1050	1000	931	3512	780	740
TS_(2S)-B 14040-15-7	2	140	40	15,875	127	7	975	3684	1250	1150	1068	4135	900	840
TS_(2S)-B 14040-15-8	2	140	40	15,875	127	8	1098	4238	1400	1250	1202	4757	1000	920
TS_(2S)-B 14040-15-9	2	140	40	15,875	127	9	1202	4694	1500	1350	1316	5268	1100	980
TS_(2S)-B 14040-15-10	2	140	40	15,875	127	10	1317	5229	1650	1400	1443	5869	1200	1050
TS_(2S)-B 14050-19-2	2	140	50	19,05	124,1	2	432	1158	480	470	486	1342	320	320
TS_(2S)-B 14050-19-3	2	140	50	19,05	124,1	3	606	1836	740	720	680	2127	500	490
TS_(2S)-B 14050-19-4	2	140	50	19,05	124,1	4	779	2513	990	960	875	2912	670	650
TS_(2S)-B 14050-19-5	2	140	50	19,05	124,1	5	949	3191	1200	1150	1066	3698	830	790
TS_(2S)-B 14050-19-6	2	140	50	19,05	124,1	6	1076	3671	1400	1300	1209	4254	950	880
TS_(2S)-B 14050-19-7	2	140	50	19,05	124,1	7	1240	4349	1600	1450	1393	5039	1100	990
TS_(2S)-B 14050-19-8	2	140	50	19,05	124,1	8	1400	5027	1800	1550	1573	5824	1250	1050
TS_-B 16020-15-2	1	160	20	15,875	147	2	237	695	250	250	259	780	180	180
TS_-B 16020-15-3	1	160	20	15,875	147	3	329	1090	380	380	361	1224	280	280
TS_-B 16020-15-4	1	160	20	15,875	147	4	404	1390	500	490	442	1560	360	360
TS_-B 16020-15-5	1	160	20	15,875	147	5	493	1773	630	620	540	1990	460	460
TS_-B 16020-15-6	1	160	20	15,875	147	6	585	2181	760	750	641	2447	560	550
TS_-B 16020-15-7	1	160	20	15,875	147	7	656	2480	870	850	719	2783	640	630
TS_-B 16020-15-8	1	160	20	15,875	147	8	743	2875	1000	980	813	3227	740	720
TS_-B 16020-15-9	1	160	20	15,875	147	9	827	3271	1150	1100	906	3671	830	810

* C_a and C_{oa} : Modified static and dynamic load capacities, calculated according to DIN 69051/4 standard and ISO3408/5. See pages 39 and 43.

** Rb/t : Rigidity of the balls contact zone for an external force 20% of C_a . See page 46. For different forces, multiply by $\sqrt[3]{F/0,2 C_a}$

*** Rnu : Total rigidity of the complete nut. It must be multiplied by the factor f_{an} , which depends on the manufacturing tolerance. See page 48.

**** Check with SHUTON in case higher loads or more adjusted nut dimensions are required.

***** Check external maximum axial force in the two senses.

For the indicated leads, in case C_a and C_{oa} requirements is lower, there is possibility of smaller size balls

Nut length	Nut dimensions, B-type recirculation, 8 hole design <small>*dimensions of 12 hole design check with Shuton</small>										Grease quantity TS 'steel ball'	Ball screw reference TSB Flanged single nut TSL Cylindrical single nut Recirculation U and B
	TSB	D_1	$D_{L,min}$	D_4	D_6	M	D_5	L_7	L_1	L_8		
109	195	(190)	221 (216)	247 (242)	M16	17,5	40	40	200 (195)	223,5 (218,5)	139	TS_(2S)-B 14032-12-2
141	195	(190)	221 (216)	247 (242)	M16	17,5	40	40	200 (195)	223,5 (218,5)	170	TS_(2S)-B 14032-12-3
173	195	(190)	221 (216)	247 (242)	M16	17,5	40	40	200 (195)	223,5 (218,5)	205	TS_(2S)-B 14032-12-4
221	195	(190)	221 (216)	247 (242)	M16	17,5	40	40	200 (195)	223,5 (218,5)	281	TS_(2S)-B 14032-12-5
253	195	(190)	221 (216)	247 (242)	M16	17,5	40	40	200 (195)	223,5 (218,5)	312	TS_(2S)-B 14032-12-6
285	195	(190)	221 (216)	247 (242)	M16	17,5	40	40	200 (195)	223,5 (218,5)	349	TS_(2S)-B 14032-12-7
317	195	(190)	221 (216)	247 (242)	M16	17,5	40	40	200 (195)	223,5 (218,5)	383	TS_(2S)-B 14032-12-8
355	195	(190)	221 (216)	247 (242)	M16	17,5	40	40	200 (195)	223,5 (218,5)	430	TS_(2S)-B 14032-12-9
385	195	(190)	221 (216)	247 (242)	M16	17,5	40	40	200 (195)	223,5 (218,5)	457	TS_(2S)-B 14032-12-10
417	195	(190)	224 (219)	253 (248)	M18	20	40	40	200 (195)	226,5 (221,5)	494	TS_(2S)-B 14032-12-11
449	195	(190)	224 (219)	253 (248)	M18	20	40	40	200 (195)	226,5 (221,5)	530	TS_(2S)-B 14032-12-12
483	195	(190)	224 (219)	253 (248)	M18	20	40	40	200 (195)	226,5 (221,5)	566	TS_(2S)-B 14032-12-13
131	210	(205)	236 (231)	262 (257)	M16	17,5	45	40	215 (210)	238,5 (233,5)	229	TS_(2S)-B 14040-15-2
171	210	(205)	236 (231)	262 (257)	M16	17,5	45	40	215 (210)	238,5 (233,5)	281	TS_(2S)-B 14040-15-3
211	210	(205)	236 (231)	262 (257)	M16	17,5	45	40	215 (210)	238,5 (233,5)	339	TS_(2S)-B 14040-15-4
271	210	(205)	236 (231)	262 (257)	M16	17,5	45	40	215 (210)	238,5 (233,5)	466	TS_(2S)-B 14040-15-5
311	210	(205)	239 (234)	268 (263)	M18	20	45	40	215 (210)	241,5 (236,5)	520	TS_(2S)-B 14040-15-6
351	210	(205)	242 (237)	274 (269)	M20	22	45	40	215 (210)	244,5 (239,5)	575	TS_(2S)-B 14040-15-7
389	210	(205)	242 (237)	274 (269)	M20	22	45	40	215 (210)	244,5 (239,5)	629	TS_(2S)-B 14040-15-8
436	210	(205)	242 (237)	274 (269)	M20	22	45	40	215 (210)	244,5 (239,5)	712	TS_(2S)-B 14040-15-9
476	210	(205)	245 (240)	280 (275)	M22	24	45	40	215 (210)	247,5 (242,5)	772	TS_(2S)-B 14040-15-10
157	220	(215)	246 (241)	272 (267)	M16	17,5	50	40	225 (220)	248,5 (243,5)	326	TS_(2S)-B 14050-19-2
207	220	(215)	246 (241)	272 (267)	M16	17,5	50	40	225 (220)	248,5 (243,5)	405	TS_(2S)-B 14050-19-3
257	220	(215)	249 (244)	278 (273)	M18	20	50	40	225 (220)	251,5 (246,5)	484	TS_(2S)-B 14050-19-4
307	220	(215)	252 (247)	284 (279)	M20	22	50	40	225 (220)	254,5 (249,5)	568	TS_(2S)-B 14050-19-5
380	220	(215)	252 (247)	284 (279)	M20	22	50	40	225 (220)	254,5 (249,5)	751	TS_(2S)-B 14050-19-6
430	220	(215)	255 (250)	290 (285)	M22	24	50	40	225 (220)	257,5 (252,5)	830	TS_(2S)-B 14050-19-7
480	220	(215)	255 (250)	290 (285)	M22	24	50	40	225 (220)	257,5 (252,5)	909	TS_(2S)-B 14050-19-8
89	230		256	282	M16	17,5	45	40	235	258,5	188	TS_-B 16020-15-2
109	230		256	282	M16	17,5	45	40	235	258,5	218	TS_-B 16020-15-3
139	230		256	282	M16	17,5	45	40	235	258,5	292	TS_-B 16020-15-4
159	230		256	282	M16	17,5	45	40	235	258,5	323	TS_-B 16020-15-5
179	230		256	282	M16	17,5	45	40	235	258,5	353	TS_-B 16020-15-6
203	230		256	282	M16	17,5	45	40	235	258,5	405	TS_-B 16020-15-7
223	230		259	288	M18	20	45	40	235	261,5	436	TS_-B 16020-15-8
243	230		259	288	M18	20	45	40	235	261,5	466	TS_-B 16020-15-9

Key dimensions of the cylindrical nut: N, M, Y are obtained in the tables of page 38 of the catalogue.

SHUTON advises to use the dimensions of the tables, although it is possible to manufacture ball screw with other dimensions. In brackets () second options. Smaller nut diameters than the first option of the table can reduce the rigidity of the assembly between 5 and 10%.

Please consult SHUTON.

HIGH LOADS, Single nut

Ball screw reference TSB Flanged single nut TSL Cylindrical single nut Recirculation U and B	No. Starts	Nominal diameter	Lead	Ball diameter	Root diameter	Circuits	IML Type				HDL Type			
							Dynamic load capacity [kN]	Static load capacity [kN]	Maximum recommended external force with loads CO-CO TR-TR [kN]	Maximum recommended external force with loads CO-TR [kN]	Dynamic load capacity [kN]	Static load capacity [kN]	Maximum recommended external force with loads CO-CO TR-TR [kN]	Maximum recommended external force with loads CO-TR [kN]
	$l/2$	d_0	P_h	D_w	d_2	$i (I_e)$	$C_a (kN)$	$C_{oa} (kN)$	F_{max,CO^2TR^2}	$F_{max,CO-TR}$	$C_a (kN)$	$C_{oa} (kN)$	F_{max,CO^2TR^2}	$F_{max,CO-TR}$
TS_-B 12012,7-9-3	1	120	12,7	9,525	112,2	3	136	458	150	150				
TS_-B 12012,7-9-4	1	120	12,7	9,525	112,2	4	169	595	190	190				
TS_-B 12012,7-9-5	1	120	12,7	9,525	112,2	5	206	756	240	240				
TS_-B 12012,7-9-6	1	120	12,7	9,525	112,2	6	242	916	290	290				
TS_-B 12012,7-9-7	1	120	12,7	9,525	112,2	7	272	1049	340	340				
TS_-B 12012,7-9-8	1	120	12,7	9,525	112,2	8	308	1218	390	380				
TS_-B 12012,7-9-9	1	120	12,7	9,525	112,2	9	342	1375	440	430				
TS_-B 12012,7-9-10	1	120	12,7	9,525	112,2	10	371	1511	480	480				
TS_-B 12012,7-9-11	1	120	12,7	9,525	112,2	11	404	1672	530	520				
TS_-B 12012,7-9-12	1	120	12,7	9,525	112,2	12	437	1833	580	570				
TS_-B 12012,7-9-13	1	120	12,7	9,525	112,2	13	466	1970	620	610				
TS_-B 12012,7-9-14	1	120	12,7	9,525	112,2	14	498	2130	670	660				
TS_-B 12012,7-9-15	1	120	12,7	9,525	112,2	15	530	2291	720	700				
TS_-B 12016-12-2	1	120	16	12,7	111	2	149	405	75	75	162	443	95	95
TS_-B 12016-12-3	1	120	16	12,7	111	3	208	633	110	110	226	698	150	150
TS_-B 12016-12-4	1	120	16	12,7	111	4	264	854	150	150	289	944	200	200
TS_-B 12016-12-5	1	120	16	12,7	111	5	311	1031	190	190	342	1150	250	250
TS_-B 12016-12-6	1	120	16	12,7	111	6	369	1266	230	230	402	1396	300	300
TS_-B 12016-12-7	1	120	16	12,7	111	7	422	1487	270	260	461	1642	350	350
TS_-B 12016-12-8	1	120	16	12,7	111	8	475	1708	310	300	519	1889	410	400
TS_-B 12016-12-9	1	120	16	12,7	111	9	521	1899	340	340	569	2094	450	450
TS_-B 12016-12-10	1	120	16	12,7	111	10	572	2120	380	370	625	2340	500	490
TS_-B 12016-12-11	1	120	16	12,7	111	11	623	2341	420	410	680	2587	550	530
TS_-B 12016-12-12	1	120	16	12,7	111	12	672	2562	450	440	735	2833	590	580
TS_-B 12016-12-13	1	120	16	12,7	111	13	714	2739	480	470	779	3022	640	620
TS_-B 12016-12-14	1	120	16	12,7	111	14	765	2974	520	500	836	3285	690	660
TS_-B 12016-12-15	1	120	16	12,7	111	15	816	3210	560	530	891	3547	740	700
TS_-B 12016-12-16	1	120	16	12,7	111	16	861	3416	590	560	941	3777	780	730
TS_-B 12016-12-17	1	120	16	12,7	111	17	903	3607	630	590	986	3983	820	770
TS_-B 12016-12-18	1	120	16	12,7	111	18	950	3828	660	610	1038	4229	860	800
TS_-B 12016-12-19	1	120	16	12,7	111	19	996	4049	690	630	1089	4475	900	830
TS_-B 12016-12-20	1	120	16	12,7	111	20	1043	4270	720	660	1140	4722	950	860
TS_-B 12020-15-2	1	120	20	15,875	107	2	204	497	180	180	223	558	130	130
TS_-B 12020-15-3	1	120	20	15,875	107	3	287	793	280	280	314	890	210	210
TS_-B 12020-15-4	1	120	20	15,875	107	4	367	1077	380	380	402	1209	280	280
TS_-B 12020-15-5	1	120	20	15,875	107	5	448	1373	470	470	491	1541	350	340

* C_a and C_{oa} : Modified static and dynamic load capacities, calculated according to DIN 69051/4 standard and ISO3408/5. See pages 39 and 43.

** Rb/t : Rigidity of the balls contact zone for an external force 20% of C_a . See page 46. For different forces, multiply by $\sqrt[3]{F/0,2 C_a}$

*** Rnu : Total rigidity of the complete nut. It must be multiplied by the factor f_{an} , which depends on the manufacturing tolerance. See page 48.

**** Check with SHUTON in case higher loads or more adjusted nut dimensions are required.

***** Check external maximum axial force in the two senses.

For the indicated leads, in case C_a and C_{oa} requirements is lower, there is possibility of smaller size balls

Nut length	Nut dimensions, B-type recirculation, 8 hole design <small>*dimensions of 12 hole design check with Shuton</small>										Grease quantity TS 'steel ball'	Ball screw reference TSB Flanged single nut TSL Cylindrical single nut Recirculation U and B
	TSB	D_1	$D_{L,min}$	D_4	D_6	M	D_5	L_7	L_1	L_8		
78	160		186	212	M16	17,5	35	25	165	188,5	65	TS_-B 12012,7-9-3
97	160		186	212	M16	17,5	35	25	165	188,5	85	TS_-B 12012,7-9-4
110	160		186	212	M16	17,5	35	25	165	188,5	94	TS_-B 12012,7-9-5
123	160		186	212	M16	17,5	35	25	165	188,5	103	TS_-B 12012,7-9-6
137	160		186	212	M16	17,5	35	25	165	188,5	116	TS_-B 12012,7-9-7
150	160		186	212	M16	17,5	35	25	165	188,5	124	TS_-B 12012,7-9-8
163	160		186	212	M16	17,5	35	25	165	188,5	134	TS_-B 12012,7-9-9
177	160		186	212	M16	17,5	35	25	165	188,5	145	TS_-B 12012,7-9-10
189	160		186	212	M16	17,5	35	25	165	188,5	153	TS_-B 12012,7-9-11
202	160		186	212	M16	17,5	35	25	165	188,5	163	TS_-B 12012,7-9-12
215	160		186	212	M16	17,5	35	25	165	188,5	173	TS_-B 12012,7-9-13
228	160		186	212	M16	17,5	35	25	165	188,5	182	TS_-B 12012,7-9-14
241	160		186	212	M16	17,5	35	25	165	188,5	192	TS_-B 12012,7-9-15
75	175	(170)	201 (196)	227 (222)	M16	17,5	40	25	180 (175)	203,5 (198,5)	89	TS_-B 12016-12-2
91	175	(170)	201 (196)	227 (222)	M16	17,5	40	25	180 (175)	203,5 (198,5)	102	TS_-B 12016-12-3
107	175	(170)	201 (196)	227 (222)	M16	17,5	40	25	180 (175)	203,5 (198,5)	117	TS_-B 12016-12-4
131	175	(170)	201 (196)	227 (222)	M16	17,5	40	25	180 (175)	203,5 (198,5)	151	TS_-B 12016-12-5
147	175	(170)	201 (196)	227 (222)	M16	17,5	40	25	180 (175)	203,5 (198,5)	164	TS_-B 12016-12-6
163	175	(170)	201 (196)	227 (222)	M16	17,5	40	25	180 (175)	203,5 (198,5)	180	TS_-B 12016-12-7
179	175	(170)	201 (196)	227 (222)	M16	17,5	40	25	180 (175)	203,5 (198,5)	194	TS_-B 12016-12-8
198	175	(170)	201 (196)	227 (222)	M16	17,5	40	25	180 (175)	203,5 (198,5)	215	TS_-B 12016-12-9
214	175	(170)	201 (196)	227 (222)	M16	17,5	40	25	180 (175)	203,5 (198,5)	230	TS_-B 12016-12-10
230	175	(170)	201 (196)	227 (222)	M16	17,5	40	25	180 (175)	203,5 (198,5)	245	TS_-B 12016-12-11
246	175	(170)	201 (196)	227 (222)	M16	17,5	40	25	180 (175)	203,5 (198,5)	260	TS_-B 12016-12-12
263	175	(170)	201 (196)	227 (222)	M16	17,5	40	25	180 (175)	203,5 (198,5)	279	TS_-B 12016-12-13
279	175	(170)	201 (196)	227 (222)	M16	17,5	40	25	180 (175)	203,5 (198,5)	293	TS_-B 12016-12-14
295	175	(170)	201 (196)	227 (222)	M16	17,5	40	25	180 (175)	203,5 (198,5)	305	TS_-B 12016-12-15
311	175	(170)	201 (196)	227 (222)	M16	17,5	40	25	180 (175)	203,5 (198,5)	322	TS_-B 12016-12-16
328	175	(170)	201 (196)	227 (222)	M16	17,5	40	25	180 (175)	203,5 (198,5)	338	TS_-B 12016-12-17
344	175	(170)	201 (196)	227 (222)	M16	17,5	40	25	180 (175)	203,5 (198,5)	354	TS_-B 12016-12-18
358	175	(170)	201 (196)	227 (222)	M16	17,5	40	25	180 (175)	203,5 (198,5)	366	TS_-B 12016-12-19
374	175	(170)	201 (196)	227 (222)	M16	17,5	40	25	180 (175)	203,5 (198,5)	379	TS_-B 12016-12-20
89	185		211	237	M16	17,5	45	40	190	213,5	144	TS_-B 12020-15-2
109	185		211	237	M16	17,5	45	40	190	213,5	167	TS_-B 12020-15-3
129	185		211	237	M16	17,5	45	40	190	213,5	192	TS_-B 12020-15-4
149	185		211	237	M16	17,5	45	40	190	213,5	216	TS_-B 12020-15-5

Key dimensions of the cylindrical nut: N, M, Y are obtained in the tables of page 38 of the catalogue.

SHUTON advises to use the dimensions of the tables, although it is possible to manufacture ball screw with other dimensions. In brackets () second options. Smaller nut diameters than the first option of the table can reduce the rigidity of the assembly between 5 and 10%.

Please consult SHUTON.

HIGH LOADS, Single nut

Ball screw reference TSB Flanged single nut TSL Cylindrical single nut Recirculation U and B	No. Starts	Nominal diameter	Lead	Ball diameter	Root diameter	Circuits	IML Type				HDL Type			
							Dynamic load capacity [kN]	Static load capacity [kN]	Maximum recommended external force with loads CO-CO TR-TR [kN]	Maximum recommended external force with loads CO-TR [kN]	Dynamic load capacity [kN]	Static load capacity [kN]	Maximum recommended external force with loads CO-CO TR-TR [kN]	Maximum recommended external force with loads CO-TR [kN]
	$l/2$	d_0	P_h	D_w	d_2	$i (I_e)$	$C_a (kN)$	$C_{oa} (kN)$	F_{max,CO^2TR^2}	$F_{max,CO-TR}$	$C_a (kN)$	$C_{oa} (kN)$	F_{max,CO^2TR^2}	$F_{max,CO-TR}$
TS_-B 12020-15-6	1	120	20	15,875	107	6	510	1586	560	560	559	1780	410	410
TS_-B 12020-15-7	1	120	20	15,875	107	7	586	1870	660	650	642	2099	480	480
TS_-B 12020-15-8	1	120	20	15,875	107	8	660	2154	740	730	723	2418	550	530
TS_-B 12020-15-9	1	120	20	15,875	107	9	733	2438	840	820	803	2737	620	600
TS_-B 12020-15-10	1	120	20	15,875	107	10	809	2746	930	900	887	3082	680	660
TS_-B 12020-15-11	1	120	20	15,875	107	11	864	2947	1000	970	947	3308	740	710
TS_-B 12020-15-12	1	120	20	15,875	107	12	934	3231	1100	1050	1023	3627	800	760
TS_-B 12020-15-13	1	120	20	15,875	107	13	1003	3515	1200	1100	1099	3946	870	820
TS_-B 12020-15-14	1	120	20	15,875	107	14	1072	3799	1250	1200	1174	4265	930	870
TS_-B 12020-15-15	1	120	20	15,875	107	15	1146	4119	1350	1250	1256	4623	990	910
TS_-B 12020-15-16	1	120	20	15,875	107	16	1196	4308	1400	1300	1310	4836	1050	940
TS_-B 12020-15-17	1	120	20	15,875	107	17	1263	4592	1500	1350	1383	5155	1100	980
TS_-B 12020-15-18	1	120	20	15,875	107	18	1329	4876	1550	1400	1456	5473	1150	1000
TS_-B 12020-15-19	1	120	20	15,875	107	19	1403	5208	1650	1450	1537	5845	1200	1050
TS_-B 12020-15-20	1	120	20	15,875	107	20	1468	5492	1700	1450	1608	6164	1250	1050
TS_-B 12025-19-2	1	120	25	19,05	104,1	2	255	574	240	240	286	665	160	160
TS_-B 12025-19-3	1	120	25	19,05	104,1	3	362	928	380	380	407	1076	260	260
TS_-B 12025-19-4	1	120	25	19,05	104,1	4	464	1266	520	510	522	1467	350	350
TS_-B 12025-19-5	1	120	25	19,05	104,1	5	568	1620	650	640	639	1878	440	430
TS_-B 12025-19-6	1	120	25	19,05	104,1	6	666	1958	760	750	749	2269	520	510
TS_-B 12025-19-7	1	120	25	19,05	104,1	7	740	2194	890	860	831	2543	600	590
TS_-B 12025-19-8	1	120	25	19,05	104,1	8	834	2531	1000	980	938	2934	690	660
TS_-B 12025-19-9	1	120	25	19,05	104,1	9	928	2869	1100	1050	1043	3325	760	730
TS_-B 12025-19-10	1	120	25	19,05	104,1	10	1026	3240	1250	1200	1154	3755	850	800
TS_-B 12025-19-11	1	120	25	19,05	104,1	11	1117	3578	1350	1300	1255	4146	920	860
TS_-B 12025-19-12	1	120	25	19,05	104,1	12	1206	3915	1450	1350	1355	4537	990	910
TS_-B 12025-19-13	1	120	25	19,05	104,1	13	1273	4152	1550	1400	1431	4811	1050	960
TS_-B 12025-19-14	1	120	25	19,05	104,1	14	1364	4506	1650	1500	1533	5222	1150	1000
TS_-B 12025-19-15	1	120	25	19,05	104,1	15	1454	4860	1750	1550	1634	5633	1200	1050
TS_-B 12025-19-16	1	120	25	19,05	104,1	16	1532	5164	1850	1550	1722	5985	1250	1050
TS_-B 12032-25-2	1	120	32	25,4	98,7	2					416	866	180	180
TS_-B 12032-25-3	1	120	32	25,4	98,7	3					603	1444	300	300
TS_-B 12032-25-4	1	120	32	25,4	98,7	4					778	1985	420	410
TS_-B 12032-25-5	1	120	32	25,4	98,7	5					958	2562	530	510
TS_-B 12032-25-6	1	120	32	25,4	98,7	6					1125	3104	620	600
TS_-B 12032-25-7	1	120	32	25,4	98,7	7					1297	3681	720	690

* C_a and C_{oa} : Modified static and dynamic load capacities, calculated according to DIN 69051/4 standard and ISO3408/5. See pages 39 and 43.

** Rb/t : Rigidity of the balls contact zone for an external force 20% of C_a . See page 46. For different forces, multiply by $\sqrt[3]{F/0,2 C_a}$

*** Rnu : Total rigidity of the complete nut. It must be multiplied by the factor f_{an} , which depends on the manufacturing tolerance. See page 48.

**** Check with SHUTON in case higher loads or more adjusted nut dimensions are required.

***** Check external maximum axial force in the two senses.

For the indicated leads, in case C_a and C_{oa} requirements is lower, there is possibility of smaller size balls

Nut length	Nut dimensions, B-type recirculation, 8 hole design <small>*dimensions of 12 hole design check with Shuton</small>										Grease quantity TS 'steel ball'	Ball screw reference TSB Flanged single nut TSL Cylindrical single nut Recirculation U and B
	TSB	D_1	$D_{L,min}$	D_4	D_6	M	D_5	L_7	L_1	L_8		
179	185		211	237	M16	17,5	45	40	190	213,5	270	TS_B 12020-15-6
199	185		211	237	M16	17,5	45	40	190	213,5	294	TS_B 12020-15-7
219	185		211	237	M16	17,5	45	40	190	213,5	321	TS_B 12020-15-8
239	185		211	237	M16	17,5	45	40	190	213,5	345	TS_B 12020-15-9
259	185		211	237	M16	17,5	45	40	190	213,5	369	TS_B 12020-15-10
283	185		214	243	M18	20	45	40	190	216,5	408	TS_B 12020-15-11
303	185		214	243	M18	20	45	40	190	216,5	434	TS_B 12020-15-12
323	185		217	249	M20	22	45	40	190	219,5	455	TS_B 12020-15-13
343	185		217	249	M20	22	45	40	190	219,5	480	TS_B 12020-15-14
361	185		217	249	M20	22	45	40	190	219,5	500	TS_B 12020-15-15
382	185		217	249	M20	22	45	40	190	219,5	532	TS_B 12020-15-16
402	185		217	249	M20	22	45	40	190	219,5	554	TS_B 12020-15-17
422	185		220	255	M22	24	45	40	190	222,5	581	TS_B 12020-15-18
442	185		220	255	M22	24	45	40	190	222,5	602	TS_B 12020-15-19
462	185		220	255	M22	24	45	40	190	222,5	629	TS_B 12020-15-20
105	195	(190)	221 (216)	247 (242)	M16	17,5	50	40	200 (195)	223,5 (218,5)	206	TS_B 12025-19-2
130	195	(190)	221 (216)	247 (242)	M16	17,5	50	40	200 (195)	223,5 (218,5)	239	TS_B 12025-19-3
155	195	(190)	221 (216)	247 (242)	M16	17,5	50	40	200 (195)	223,5 (218,5)	273	TS_B 12025-19-4
180	195	(190)	221 (216)	247 (242)	M16	17,5	50	40	200 (195)	223,5 (218,5)	309	TS_B 12025-19-5
205	195	(190)	221 (216)	247 (242)	M16	17,5	50	40	200 (195)	223,5 (218,5)	347	TS_B 12025-19-6
243	195	(190)	221 (216)	247 (242)	M16	17,5	50	40	200 (195)	223,5 (218,5)	427	TS_B 12025-19-7
268	195	(190)	224 (219)	253 (248)	M18	20	50	40	200 (195)	226,5 (221,5)	463	TS_B 12025-19-8
293	195	(190)	224 (219)	253 (248)	M18	20	50	40	200 (195)	226,5 (221,5)	504	TS_B 12025-19-9
318	195	(190)	227 (222)	259 (254)	M20	22	50	40	200 (195)	229,5 (224,5)	535	TS_B 12025-19-10
343	195	(190)	227 (222)	259 (254)	M20	22	50	40	200 (195)	229,5 (224,5)	571	TS_B 12025-19-11
366	195	(190)	227 (222)	259 (254)	M20	22	50	40	200 (195)	229,5 (224,5)	605	TS_B 12025-19-12
395	195	(190)	230 (225)	265 (260)	M22	24	50	40	200 (195)	232,5 (227,5)	654	TS_B 12025-19-13
420	195	(190)	230 (225)	265 (260)	M22	24	50	40	200 (195)	232,5 (227,5)	690	TS_B 12025-19-14
445	195	(190)	230 (225)	265 (260)	M22	24	50	40	200 (195)	232,5 (227,5)	726	TS_B 12025-19-15
470	195	(190)	230 (225)	265 (260)	M22	24	50	40	200 (195)	232,5 (227,5)	769	TS_B 12025-19-16
130	210		243	275	M20	22	60	40	215	245	560	TS_B 12032-25-2
162	210		243	275	M20	22	60	40	215	245	642	TS_B 12032-25-3
194	210		243	275	M20	22	60	40	215	245	732	TS_B 12032-25-4
226	210		243	275	M20	22	60	40	215	245	823	TS_B 12032-25-5
258	210		243	275	M20	22	60	40	215	245	922	TS_B 12032-25-6
290	210		243	275	M20	22	60	40	215	245	1020	TS_B 12032-25-7

Key dimensions of the cylindrical nut: N, M, Y are obtained in the tables of page 38 of the catalogue.

SHUTON advises to use the dimensions of the tables, although it is possible to manufacture ball screw with other dimensions. In brackets () second options. Smaller nut diameters than the first option of the table can reduce the rigidity of the assembly between 5 and 10%.

Please consult SHUTON.

HIGH LOADS, Single nut

Ball screw reference TSB Flanged single nut TSL Cylindrical single nut Recirculation U and B	No. Starts	Nominal diameter	Lead	Ball diameter	Root diameter	Circuits	IML Type				HDL Type				
							Dynamic load capacity [kN]	Static load capacity [kN]	Maximum recommended external force with loads CO-CO TR-TR [kN]	Maximum recommended external force with loads CO-TR [kN]	Dynamic load capacity [kN]	Static load capacity [kN]	Maximum recommended external force with loads CO-CO TR-TR [kN]	Maximum recommended external force with loads CO-TR [kN]	
							C_a (kN)	C_{oa} (kN)	F_{max,CO^2TR^2}	$F_{max,CO-TR}$	C_a (kN)	C_{oa} (kN)	F_{max,CO^2TR^2}	$F_{max,CO-TR}$	
	$l/2$	d_0	P_h	D_w	d_2	i (1e)									
TS_-B 12032-25-8	1	120	32	25,4	98,7	8						1399	3970	800	750
TS_-B 12032-25-9	1	120	32	25,4	98,7	9						1566	4547	890	830
TS_-B 12032-25-10	1	120	32	25,4	98,7	10						1730	5124	990	900
TS_-B 12032-25-11	1	120	32	25,4	98,7	11						1876	5630	1050	950
TS_-B 12032-25-12	1	120	32	25,4	98,7	12						2035	6207	1150	1000
TS_(2S)-B 12025-9-2	2	120	25	9,525	112,2	2	153	495	160	160					
TS_(2S)-B 12025-9-3	2	120	25	9,525	112,2	3	211	763	240	240					
TS_(2S)-B 12025-9-4	2	120	25	9,525	112,2	4	261	990	320	310					
TS_(2S)-B 12025-9-5	2	120	25	9,525	112,2	5	318	1257	400	390					
TS_(2S)-B 12025-9-6	2	120	25	9,525	112,2	6	374	1525	480	470					
TS_(2S)-B 12025-9-7	2	120	25	9,525	112,2	7	425	1766	550	540					
TS_(2S)-B 12025-9-8	2	120	25	9,525	112,2	8	477	2027	630	610					
TS_(2S)-B 12025-9-9	2	120	25	9,525	112,2	9	529	2288	700	670					
TS_(2S)-B 12025-9-10	2	120	25	9,525	112,2	10	575	2515	770	730					
TS_(2S)-B 12025-9-11	2	120	25	9,525	112,2	11	626	2782	840	790					
TS_(2S)-B 12025-9-12	2	120	25	9,525	112,2	12	677	3050	910	840					
TS_(2S)-B 12032-12-2	2	120	32	12,7	111	2	231	673	120	120	254	751	160	160	
TS_(2S)-B 12032-12-3	2	120	32	12,7	111	3	321	1053	190	190	350	1160	250	250	
TS_(2S)-B 12032-12-4	2	120	32	12,7	111	4	411	1432	260	250	449	1584	340	330	
TS_(2S)-B 12032-12-5	2	120	32	12,7	111	5	481	1714	310	300	529	1911	410	400	
TS_(2S)-B 12032-12-6	2	120	32	12,7	111	6	570	2105	380	360	622	2321	500	480	
TS_(2S)-B 12032-12-7	2	120	32	12,7	111	7	653	2472	430	420	713	2730	570	550	
TS_(2S)-B 12032-12-8	2	120	32	12,7	111	8	739	2864	490	460	808	3167	650	620	
TS_(2S)-B 12032-12-9	2	120	32	12,7	111	9	806	3158	540	500	880	3481	720	670	
TS_(2S)-B 12032-12-10	2	120	32	12,7	111	10	885	3525	590	540	966	3891	780	720	
TS_(2S)-B 12032-12-11	2	120	32	12,7	111	11	963	3892	640	570	1052	4300	850	760	
TS_(2S)-B 12032-12-12	2	120	32	12,7	111	12	1046	4296	700	600	1143	4750	920	800	
TS_(2S)-B 12032-12-13	2	120	32	12,7	111	13	1112	4602	730	620	1214	5078	970	820	
TS_(2S)-B 12040-15-2	2	120	40	15,875	107	2	320	845	300	300	350	948	220	220	
TS_(2S)-B 12040-15-3	2	120	40	15,875	107	3	443	1316	470	460	485	1478	340	340	
TS_(2S)-B 12040-15-4	2	120	40	15,875	107	4	571	1808	620	610	625	2029	460	450	
TS_(2S)-B 12040-15-5	2	120	40	15,875	107	5	692	2279	770	740	758	2558	560	550	
TS_(2S)-B 12040-15-6	2	120	40	15,875	107	6	787	2633	900	860	862	2955	660	630	
TS_(2S)-B 12040-15-7	2	120	40	15,875	107	7	904	3104	1050	980	990	3485	770	710	
TS_(2S)-B 12040-15-8	2	120	40	15,875	107	8	1026	3615	1200	1050	1124	4058	870	790	
TS_(2S)-B 12040-15-9	2	120	40	15,875	107	9	1139	4087	1300	1150	1247	4587	950	850	

* C_a and C_{oa} : Modified static and dynamic load capacities, calculated according to DIN 69051/4 standard and ISO3408/5. See pages 39 and 43.

** Rb/t : Rigidity of the balls contact zone for an external force 20% of C_a . See page 46. For different forces, multiply by $\sqrt[3]{F/0,2 C_a}$

*** Rnu : Total rigidity of the complete nut. It must be multiplied by the factor f_{an} , which depends on the manufacturing tolerance. See page 48.

**** Check with SHUTON in case higher loads or more adjusted nut dimensions are required.

***** Check external maximum axial force in the two senses.

For the indicated leads, in case C_a and C_{oa} requirements is lower, there is possibility of smaller size balls

Nut length	Nut dimensions, B-type recirculation, 8 hole design <small>*dimensions of 12 hole design check with Shuton</small>										Grease quantity TS 'steel ball'	Ball screw reference TSB Flanged single nut TSL Cylindrical single nut Recirculation U and B
	TSB	D_1	$D_{L,min}$	D_4	D_6	M	D_5	L_7	L_1	L_8		
338	210		243	275	M20	22	60	40	215	245	1242	TS_-B 12032-25-8
370	210		243	275	M20	22	60	40	215	245	1332	TS_-B 12032-25-9
400	210		243	275	M20	22	60	40	215	245	1409	TS_-B 12032-25-10
432	210		243	275	M20	22	60	40	215	245	1517	TS_-B 12032-25-11
464	210		243	275	M20	22	60	40	215	245	1607	TS_-B 12032-25-12
92	160		186	212	M16	17,5	35	25	165	188,5	75	TS_(2S)-B 12025-9-2
117	160		186	212	M16	17,5	35	25	165	188,5	93	TS_(2S)-B 12025-9-3
154	160		186	212	M16	17,5	35	25	165	188,5	131	TS_(2S)-B 12025-9-4
179	160		186	212	M16	17,5	35	25	165	188,5	148	TS_(2S)-B 12025-9-5
204	160		186	212	M16	17,5	35	25	165	188,5	166	TS_(2S)-B 12025-9-6
234	160		186	212	M16	17,5	35	25	165	188,5	193	TS_(2S)-B 12025-9-7
259	160		186	212	M16	17,5	35	25	165	188,5	211	TS_(2S)-B 12025-9-8
284	160		186	212	M16	17,5	35	25	165	188,5	229	TS_(2S)-B 12025-9-9
311	160		186	212	M16	17,5	35	25	165	188,5	250	TS_(2S)-B 12025-9-10
336	160		186	212	M16	17,5	35	25	165	188,5	268	TS_(2S)-B 12025-9-11
359	160		186	212	M16	17,5	35	25	165	188,5	283	TS_(2S)-B 12025-9-12
109	175	(170)	201 (196)	227 (222)	M16	17,5	40	25	180 (175)	203,5 (198,5)	120	TS_(2S)-B 12032-12-2
141	175	(170)	201 (196)	227 (222)	M16	17,5	40	25	180 (175)	203,5 (198,5)	147	TS_(2S)-B 12032-12-3
173	175	(170)	201 (196)	227 (222)	M16	17,5	40	25	180 (175)	203,5 (198,5)	176	TS_(2S)-B 12032-12-4
221	175	(170)	201 (196)	227 (222)	M16	17,5	40	25	180 (175)	203,5 (198,5)	246	TS_(2S)-B 12032-12-5
253	175	(170)	201 (196)	227 (222)	M16	17,5	40	25	180 (175)	203,5 (198,5)	271	TS_(2S)-B 12032-12-6
285	175	(170)	201 (196)	227 (222)	M16	17,5	40	25	180 (175)	203,5 (198,5)	303	TS_(2S)-B 12032-12-7
317	175	(170)	201 (196)	227 (222)	M16	17,5	40	25	180 (175)	203,5 (198,5)	328	TS_(2S)-B 12032-12-8
355	175	(170)	201 (196)	227 (222)	M16	17,5	40	25	180 (175)	203,5 (198,5)	374	TS_(2S)-B 12032-12-9
385	175	(170)	201 (196)	227 (222)	M16	17,5	40	25	180 (175)	203,5 (198,5)	399	TS_(2S)-B 12032-12-10
417	175	(170)	201 (196)	227 (222)	M16	17,5	40	25	180 (175)	203,5 (198,5)	429	TS_(2S)-B 12032-12-11
449	175	(170)	201 (196)	227 (222)	M16	17,5	40	25	180 (175)	203,5 (198,5)	455	TS_(2S)-B 12032-12-12
483	175	(170)	201 (196)	227 (222)	M16	17,5	40	25	180 (175)	203,5 (198,5)	492	TS_(2S)-B 12032-12-13
131	185		211	237	M16	17,5	45	40	190	213,5	196	TS_(2S)-B 12040-15-2
171	185		211	237	M16	17,5	45	40	190	213,5	244	TS_(2S)-B 12040-15-3
211	185		211	237	M16	17,5	45	40	190	213,5	292	TS_(2S)-B 12040-15-4
251	185		211	237	M16	17,5	45	40	190	213,5	343	TS_(2S)-B 12040-15-5
311	185		211	237	M16	17,5	45	40	190	213,5	452	TS_(2S)-B 12040-15-6
351	185		214	243	M18	20	45	40	190	216,5	501	TS_(2S)-B 12040-15-7
389	185		217	249	M20	22	45	40	190	219,5	543	TS_(2S)-B 12040-15-8
429	185		217	249	M20	22	45	40	190	219,5	592	TS_(2S)-B 12040-15-9

Key dimensions of the cylindrical nut: N, M, Y are obtained in the tables of page 38 of the catalogue.

SHUTON advises to use the dimensions of the tables, although it is possible to manufacture ball screw with other dimensions. In brackets () second options. Smaller nut diameters than the first option of the table can reduce the rigidity of the assembly between 5 and 10%.

Please consult SHUTON.

HIGH LOADS, Single nut

Ball screw reference TSB Flanged single nut TSL Cylindrical single nut Recirculation U and B	No. Starts	Nominal diameter	Lead	Ball diameter	Root diameter	Circuits	IML Type				HDL Type			
							Dynamic load capacity [kN]	Static load capacity [kN]	Maximum recommended external force with loads CO-CO TR-TR [kN]	Maximum recommended external force with loads CO-TR [kN]	Dynamic load capacity [kN]	Static load capacity [kN]	Maximum recommended external force with loads CO-CO TR-TR [kN]	Maximum recommended external force with loads CO-TR [kN]
	$l/2$	d_0	P_h	D_w	d_2	$i (I_e)$	$C_a (kN)$	$C_{oa} (kN)$	F_{max,CO^2TR^2}	$F_{max,CO-TR}$	$C_a (kN)$	$C_{oa} (kN)$	F_{max,CO^2TR^2}	$F_{max,CO-TR}$
TS_(2S)-B 12040-15-10	2	120	40	15,875	107	10	1249	4558	1400	1200	1369	5117	1050	880
TS_(2S)-B 12050-19-2	2	120	50	19,05	104,1	2	400	978	400	400	450	1134	270	270
TS_(2S)-B 12050-19-3	2	120	50	19,05	104,1	3	557	1538	610	600	626	1782	420	410
TS_(2S)-B 12050-19-4	2	120	50	19,05	104,1	4	721	2125	840	810	810	2462	570	550
TS_(2S)-B 12050-19-5	2	120	50	19,05	104,1	5	875	2684	1050	970	983	3110	700	660
TS_(2S)-B 12050-19-6	2	120	50	19,05	104,1	6	990	3075	1150	1050	1113	3564	800	740
TS_(2S)-B 12050-19-7	2	120	50	19,05	104,1	7	1139	3634	1350	1200	1280	4211	920	820
TS_(2S)-B 12050-19-8	2	120	50	19,05	104,1	8	1296	4249	1550	1300	1456	4924	1050	890
TS_-B 14016-12-2	1	140	16	12,7	131	2	161	481	90	90	175	528	110	110
TS_-B 14016-12-3	1	140	16	12,7	131	3	221	740	130	130	243	826	180	180
TS_-B 14016-12-4	1	140	16	12,7	131	4	283	1007	180	180	309	1115	240	240
TS_-B 14016-12-5	1	140	16	12,7	131	5	335	1229	220	220	366	1354	290	290
TS_-B 14016-12-6	1	140	16	12,7	131	6	393	1480	270	270	432	1651	360	360
TS_-B 14016-12-7	1	140	16	12,7	131	7	451	1747	310	310	493	1932	420	410
TS_-B 14016-12-8	1	140	16	12,7	131	8	508	2013	360	350	556	2229	470	470
TS_-B 14016-12-9	1	140	16	12,7	131	9	555	2220	400	390	610	2477	530	520
TS_-B 14016-12-10	1	140	16	12,7	131	10	610	2487	440	430	667	2749	590	580
TS_-B 14016-12-11	1	140	16	12,7	131	11	665	2753	490	480	728	3047	650	630
TS_-B 14016-12-12	1	140	16	12,7	131	12	720	3020	530	510	787	3344	700	680
TS_-B 14016-12-13	1	140	16	12,7	131	13	764	3227	570	550	840	3600	760	730
TS_-B 14016-12-14	1	140	16	12,7	131	14	817	3493	610	580	893	3864	810	780
TS_-B 14016-12-15	1	140	16	12,7	131	15	869	3760	660	630	951	4161	860	820
TS_-B 14016-12-16	1	140	16	12,7	131	16	921	4026	690	650	1008	4458	920	870
TS_-B 14016-12-17	1	140	16	12,7	131	17	967	4256	730	690	1057	4706	980	920
TS_-B 14016-12-18	1	140	16	12,7	131	18	1017	4515	770	710	1112	4995	1050	950
TS_-B 14016-12-19	1	140	16	12,7	131	19	1067	4774	810	740	1167	5284	1100	990
TS_-B 14016-12-20	1	140	16	12,7	131	20	1116	5033	840	770	1221	5573	1100	1000
TS_-B 14020-15-2	1	140	20	15,875	127	2	221	596	210	210	242	669	160	160
TS_-B 14020-15-3	1	140	20	15,875	127	3	310	942	330	330	339	1057	240	240
TS_-B 14020-15-4	1	140	20	15,875	127	4	395	1275	450	440	433	1431	330	330
TS_-B 14020-15-5	1	140	20	15,875	127	5	463	1526	540	530	507	1712	400	390
TS_-B 14020-15-6	1	140	20	15,875	127	6	550	1883	660	660	602	2114	490	480
TS_-B 14020-15-7	1	140	20	15,875	127	7	631	2217	780	760	691	2488	570	560
TS_-B 14020-15-8	1	140	20	15,875	127	8	710	2551	880	860	778	2863	640	630
TS_-B 14020-15-9	1	140	20	15,875	127	9	777	2825	980	960	852	3170	720	700
TS_-B 14020-15-10	1	140	20	15,875	127	10	852	3147	1100	1050	934	3532	790	770

* C_a and C_{oa} : Modified static and dynamic load capacities, calculated according to DIN 69051/4 standard and ISO3408/5. See pages 39 and 43.

** Rb/t : Rigidity of the balls contact zone for an external force 20% of C_a . See page 46. For different forces, multiply by $\sqrt[3]{F/0,2 C_a}$

*** Rnu : Total rigidity of the complete nut. It must be multiplied by the factor f_{an} , which depends on the manufacturing tolerance. See page 48.

**** Check with SHUTON in case higher loads or more adjusted nut dimensions are required.

***** Check external maximum axial force in the two senses.

For the indicated leads, in case C_a and C_{oa} requirements is lower, there is possibility of smaller size balls

Nut length	Nut dimensions, B-type recirculation, 8 hole design <small>*dimensions of 12 hole design check with Shuton</small>										Grease quantity TS 'steel ball'	Ball screw reference TSB Flanged single nut TSL Cylindrical single nut Recirculation U and B
	TSB	D_1	$D_{L,min}$	D_4	D_6	M	D_5	L_7	L_1	L_8		
469	185		217	249	M20	22	45	40	190	219,5	646	TS_(2S)-B 12040-15-10
157	195	(190)	221 (216)	247 (242)	M16	17,5	50	40	200 (195)	223,5 (218,5)	284	TS_(2S)-B 12050-19-2
207	195	(190)	221 (216)	247 (242)	M16	17,5	50	40	200 (195)	223,5 (218,5)	357	TS_(2S)-B 12050-19-3
257	195	(190)	221 (216)	247 (242)	M16	17,5	50	40	200 (195)	223,5 (218,5)	420	TS_(2S)-B 12050-19-4
307	195	(190)	224 (219)	253 (248)	M18	20	50	40	200 (195)	226,5 (221,5)	497	TS_(2S)-B 12050-19-5
380	195	(190)	224 (219)	253 (248)	M18	20	50	40	200 (195)	226,5 (221,5)	663	TS_(2S)-B 12050-19-6
430	195	(190)	227 (222)	259 (254)	M20	22	50	40	200 (195)	229,5 (224,5)	726	TS_(2S)-B 12050-19-7
480	195	(190)	230 (225)	265 (260)	M22	24	50	40	200 (195)	232,5 (227,5)	789	TS_(2S)-B 12050-19-8
75	195	(190)	221 (216)	247 (242)	M16	17,5	40	40	200 (195)	223,5 (218,5)	103	TS_-B 14016-12-2
91	195	(190)	221 (216)	247 (242)	M16	17,5	40	40	200 (195)	223,5 (218,5)	119	TS_-B 14016-12-3
107	195	(190)	221 (216)	247 (242)	M16	17,5	40	40	200 (195)	223,5 (218,5)	136	TS_-B 14016-12-4
131	195	(190)	221 (216)	247 (242)	M16	17,5	40	40	200 (195)	223,5 (218,5)	174	TS_-B 14016-12-5
147	195	(190)	221 (216)	247 (242)	M16	17,5	40	40	200 (195)	223,5 (218,5)	191	TS_-B 14016-12-6
163	195	(190)	221 (216)	247 (242)	M16	17,5	40	40	200 (195)	223,5 (218,5)	208	TS_-B 14016-12-7
179	195	(190)	221 (216)	247 (242)	M16	17,5	40	40	200 (195)	223,5 (218,5)	224	TS_-B 14016-12-8
198	195	(190)	221 (216)	247 (242)	M16	17,5	40	40	200 (195)	223,5 (218,5)	250	TS_-B 14016-12-9
214	195	(190)	221 (216)	247 (242)	M16	17,5	40	40	200 (195)	223,5 (218,5)	266	TS_-B 14016-12-10
230	195	(190)	221 (216)	247 (242)	M16	17,5	40	40	200 (195)	223,5 (218,5)	282	TS_-B 14016-12-11
246	195	(190)	221 (216)	247 (242)	M16	17,5	40	40	200 (195)	223,5 (218,5)	301	TS_-B 14016-12-12
263	195	(190)	221 (216)	247 (242)	M16	17,5	40	40	200 (195)	223,5 (218,5)	321	TS_-B 14016-12-13
279	195	(190)	221 (216)	247 (242)	M16	17,5	40	40	200 (195)	223,5 (218,5)	338	TS_-B 14016-12-14
295	195	(190)	221 (216)	247 (242)	M16	17,5	40	40	200 (195)	223,5 (218,5)	355	TS_-B 14016-12-15
311	195	(190)	221 (216)	247 (242)	M16	17,5	40	40	200 (195)	223,5 (218,5)	372	TS_-B 14016-12-16
328	195	(190)	221 (216)	247 (242)	M16	17,5	40	40	200 (195)	223,5 (218,5)	388	TS_-B 14016-12-17
344	195	(190)	224 (219)	253 (248)	M18	20	40	40	200 (195)	226,5 (221,5)	407	TS_-B 14016-12-18
358	195	(190)	224 (219)	253 (248)	M18	20	40	40	200 (195)	226,5 (221,5)	420	TS_-B 14016-12-19
374	195	(190)	224 (219)	253 (248)	M18	20	40	40	200 (195)	226,5 (221,5)	438	TS_-B 14016-12-20
89	210	(205)	236 (231)	262 (257)	M16	17,5	45	40	215 (210)	238,5 (233,5)	167	TS_-B 14020-15-2
109	210	(205)	236 (231)	262 (257)	M16	17,5	45	40	215 (210)	238,5 (233,5)	192	TS_-B 14020-15-3
129	210	(205)	236 (231)	262 (257)	M16	17,5	45	40	215 (210)	238,5 (233,5)	221	TS_-B 14020-15-4
159	210	(205)	236 (231)	262 (257)	M16	17,5	45	40	215 (210)	238,5 (233,5)	287	TS_-B 14020-15-5
179	210	(205)	236 (231)	262 (257)	M16	17,5	45	40	215 (210)	238,5 (233,5)	312	TS_-B 14020-15-6
199	210	(205)	236 (231)	262 (257)	M16	17,5	45	40	215 (210)	238,5 (233,5)	339	TS_-B 14020-15-7
219	210	(205)	236 (231)	262 (257)	M16	17,5	45	40	215 (210)	238,5 (233,5)	369	TS_-B 14020-15-8
243	210	(205)	236 (231)	262 (257)	M16	17,5	45	40	215 (210)	238,5 (233,5)	412	TS_-B 14020-15-9
263	210	(205)	239 (234)	268 (263)	M18	20	45	40	215 (210)	241,5 (236,5)	442	TS_-B 14020-15-10

Key dimensions of the cylindrical nut: N, M, Y are obtained in the tables of page 38 of the catalogue.

SHUTON advises to use the dimensions of the tables, although it is possible to manufacture ball screw with other dimensions. In brackets () second options. Smaller nut diameters than the first option of the table can reduce the rigidity of the assembly between 5 and 10%.

Please consult SHUTON.

HIGH LOADS, Single nut

Ball screw reference TSB Flanged single nut TSL Cylindrical single nut Recirculation U and B	No. Starts	Nominal diameter	Lead	Ball diameter	Root diameter	Circuits	IML Type				HDL Type			
							Dynamic load capacity [kN]	Static load capacity [kN]	Maximum recommended external force with loads CO-CO TR-TR [kN]	Maximum recommended external force with loads CO-TR [kN]	Dynamic load capacity [kN]	Static load capacity [kN]	Maximum recommended external force with loads CO-CO TR-TR [kN]	Maximum recommended external force with loads CO-TR [kN]
	$l/2$	d_0	P_h	D_w	d_2	$i (I_e)$	$C_a (kN)$	$C_{oa} (kN)$	F_{max,CO^2TR^2}	$F_{max,CO-TR}$	$C_a (kN)$	$C_{oa} (kN)$	F_{max,CO^2TR^2}	$F_{max,CO-TR}$
TS_B 14020-15-11	1	140	20	15,875	127	11	933	3504	1200	1150	1021	3933	870	840
TS_B 14020-15-12	1	140	20	15,875	127	12	1005	3826	1300	1250	1101	4294	950	900
TS_B 14020-15-13	1	140	20	15,875	127	13	1069	4100	1400	1300	1171	4602	1000	960
TS_B 14020-15-14	1	140	20	15,875	127	14	1143	4434	1500	1400	1252	4976	1100	1000
TS_B 14020-15-15	1	140	20	15,875	127	15	1215	4767	1600	1450	1331	5351	1150	1050
TS_B 14020-15-16	1	140	20	15,875	127	16	1287	5101	1650	1500	1410	5725	1200	1100
TS_B 14020-15-17	1	140	20	15,875	127	17	1347	5363	1750	1550	1475	6020	1300	1150
TS_B 14020-15-18	1	140	20	15,875	127	18	1421	5721	1850	1650	1557	6421	1350	1200
TS_B 14020-15-19	1	140	20	15,875	127	19	1486	6019	1900	1650	1627	6755	1400	1250
TS_B 14020-15-20	1	140	20	15,875	127	20	1559	6376	2000	1700	1708	7157	1450	1250
TS_B 14025-19-2	1	140	25	19,05	124,1	2	280	698	290	290	315	809	200	200
TS_B 14025-19-3	1	140	25	19,05	124,1	3	393	1106	450	450	441	1282	310	310
TS_B 14025-19-4	1	140	25	19,05	124,1	4	501	1498	600	600	563	1736	410	410
TS_B 14025-19-5	1	140	25	19,05	124,1	5	611	1906	760	750	687	2209	510	510
TS_B 14025-19-6	1	140	25	19,05	124,1	6	698	2213	890	870	784	2564	610	590
TS_B 14025-19-7	1	140	25	19,05	124,1	7	797	2587	1050	1000	895	2998	700	680
TS_B 14025-19-8	1	140	25	19,05	124,1	8	901	2996	1200	1150	1012	3471	810	780
TS_B 14025-19-9	1	140	25	19,05	124,1	9	1003	3404	1300	1250	1127	3945	900	860
TS_B 14025-19-10	1	140	25	19,05	124,1	10	1104	3813	1450	1400	1240	4418	990	940
TS_B 14025-19-11	1	140	25	19,05	124,1	11	1177	4085	1550	1450	1322	4734	1050	990
TS_B 14025-19-12	1	140	25	19,05	124,1	12	1275	4494	1700	1600	1433	5207	1150	1100
TS_B 14025-19-13	1	140	25	19,05	124,1	13	1372	4902	1850	1650	1542	5680	1250	1150
TS_B 14025-19-14	1	140	25	19,05	124,1	14	1468	5311	1950	1750	1650	6154	1350	1200
TS_B 14025-19-15	1	140	25	19,05	124,1	15	1563	5719	2050	1800	1756	6627	1400	1250
TS_B 14025-19-16	1	140	25	19,05	124,1	16	1633	5992	2150	1850	1834	6943	1450	1250
TS_B 14032-25-2	1	140	32	25,4	118,7	2					463	1059	220	220
TS_B 14032-25-3	1	140	32	25,4	118,7	3					658	1716	360	360
TS_B 14032-25-4	1	140	32	25,4	118,7	4					852	2373	490	480
TS_B 14032-25-5	1	140	32	25,4	118,7	5					1041	3030	610	600
TS_B 14032-25-6	1	140	32	25,4	118,7	6					1226	3687	730	710
TS_B 14032-25-7	1	140	32	25,4	118,7	7					1407	4344	840	810
TS_B 14032-25-8	1	140	32	25,4	118,7	8					1531	4745	940	890
TS_B 14032-25-9	1	140	32	25,4	118,7	9					1706	5402	1050	980
TS_B 14032-25-10	1	140	32	25,4	118,7	10					1879	6059	1150	1050
TS_B 14032-25-11	1	140	32	25,4	118,7	11					2050	6716	1250	1150
TS_B 14032-25-12	1	140	32	25,4	118,7	12					2218	7373	1350	1150

* C_a and C_{oa} : Modified static and dynamic load capacities, calculated according to DIN 69051/4 standard and ISO3408/5. See pages 39 and 43.

** Rb/t : Rigidity of the balls contact zone for an external force 20% of C_a . See page 46. For different forces, multiply by $\sqrt[3]{F/0,2 C_a}$

*** Rnu : Total rigidity of the complete nut. It must be multiplied by the factor f_{an} , which depends on the manufacturing tolerance. See page 48.

**** Check with SHUTON in case higher loads or more adjusted nut dimensions are required.

***** Check external maximum axial force in the two senses.

For the indicated leads, in case C_a and C_{oa} requirements is lower, there is possibility of smaller size balls

Nut length	Nut dimensions, B-type recirculation, 8 hole design <small>*dimensions of 12 hole design check with Shuton</small>										Grease quantity TS 'steel ball'	Ball screw reference TSB Flanged single nut TSL Cylindrical single nut Recirculation U and B
	TSB	D_1	$D_{L,min}$	D_4	D_6	M	D_5	L_7	L_1	L_8		
283	210	(205)	242 (237)	274 (269)	M20	22	45	40	215 (210)	244,5 (239,5)	468	TS_B 14020-15-11
303	210	(205)	242 (237)	274 (269)	M20	22	45	40	215 (210)	244,5 (239,5)	498	TS_B 14020-15-12
324	210	(205)	242 (237)	274 (269)	M20	22	45	40	215 (210)	244,5 (239,5)	533	TS_B 14020-15-13
344	210	(205)	242 (237)	274 (269)	M20	22	45	40	215 (210)	244,5 (239,5)	557	TS_B 14020-15-14
362	210	(205)	245 (240)	280 (275)	M22	24	45	40	215 (210)	247,5 (242,5)	581	TS_B 14020-15-15
382	210	(205)	245 (240)	280 (275)	M22	24	45	40	215 (210)	247,5 (242,5)	611	TS_B 14020-15-16
403	210	(205)	245 (240)	280 (275)	M22	24	45	40	215 (210)	247,5 (242,5)	644	TS_B 14020-15-17
423	210	(205)	245 (240)	280 (275)	M22	24	45	40	215 (210)	247,5 (242,5)	666	TS_B 14020-15-18
443	210	(205)	245 (240)	280 (275)	M22	24	45	40	215 (210)	247,5 (242,5)	702	TS_B 14020-15-19
463	210	(205)	248 (243)	286 (281)	M24	26	45	40	215 (210)	250,5 (245,5)	730	TS_B 14020-15-20
105	220	(215)	246 (241)	272 (267)	M16	17,5	50	40	225 (220)	248,5 (243,5)	234	TS_B 14025-19-2
130	220	(215)	246 (241)	272 (267)	M16	17,5	50	40	225 (220)	248,5 (243,5)	273	TS_B 14025-19-3
155	220	(215)	246 (241)	272 (267)	M16	17,5	50	40	225 (220)	248,5 (243,5)	315	TS_B 14025-19-4
180	220	(215)	246 (241)	272 (267)	M16	17,5	50	40	225 (220)	248,5 (243,5)	357	TS_B 14025-19-5
218	220	(215)	246 (241)	272 (267)	M16	17,5	50	40	225 (220)	248,5 (243,5)	451	TS_B 14025-19-6
243	220	(215)	249 (244)	278 (273)	M18	20	50	40	225 (220)	251,5 (246,5)	495	TS_B 14025-19-7
268	220	(215)	252 (247)	284 (279)	M20	22	50	40	225 (220)	254,5 (249,5)	534	TS_B 14025-19-8
293	220	(215)	252 (247)	284 (279)	M20	22	50	40	225 (220)	254,5 (249,5)	578	TS_B 14025-19-9
318	220	(215)	252 (247)	284 (279)	M20	22	50	40	225 (220)	254,5 (249,5)	617	TS_B 14025-19-10
347	220	(215)	255 (250)	290 (285)	M22	24	50	40	225 (220)	257,5 (252,5)	686	TS_B 14025-19-11
370	220	(215)	255 (250)	290 (285)	M22	24	50	40	225 (220)	257,5 (252,5)	713	TS_B 14025-19-12
395	220	(215)	255 (250)	290 (285)	M22	24	50	40	225 (220)	257,5 (252,5)	754	TS_B 14025-19-13
420	220	(215)	258 (253)	296 (291)	M24	26	50	40	225 (220)	260,5 (255,5)	796	TS_B 14025-19-14
445	220	(215)	258 (253)	296 (291)	M24	26	50	40	225 (220)	260,5 (255,5)	837	TS_B 14025-19-15
472	220	(215)	258 (253)	296 (291)	M24	26	50	40	225 (220)	260,5 (255,5)	891	TS_B 14025-19-16
130	235	(230)	268 (263)	300 (295)	M20	22	60	40	240 (235)	270 (265)	637	TS_B 14032-25-2
162	235	(230)	268 (263)	300 (295)	M20	22	60	40	240 (235)	270 (265)	736	TS_B 14032-25-3
194	235	(230)	268 (263)	300 (295)	M20	22	60	40	240 (235)	270 (265)	842	TS_B 14032-25-4
226	235	(230)	268 (263)	300 (295)	M20	22	60	40	240 (235)	270 (265)	949	TS_B 14032-25-5
258	235	(230)	268 (263)	300 (295)	M20	22	60	40	240 (235)	270 (265)	1064	TS_B 14032-25-6
290	235	(230)	268 (263)	300 (295)	M20	22	60	40	240 (235)	270 (265)	1180	TS_B 14032-25-7
338	235	(230)	268 (263)	300 (295)	M20	22	60	40	240 (235)	270 (265)	1426	TS_B 14032-25-8
370	235	(230)	268 (263)	300 (295)	M20	22	60	40	240 (235)	270 (265)	1533	TS_B 14032-25-9
400	235	(230)	268 (263)	300 (295)	M20	22	60	40	240 (235)	270 (265)	1624	TS_B 14032-25-10
432	235	(230)	268 (263)	300 (295)	M20	22	60	40	240 (235)	270 (265)	1731	TS_B 14032-25-11
464	235	(230)	268 (263)	300 (295)	M20	22	60	40	240 (235)	270 (265)	1855	TS_B 14032-25-12

Key dimensions of the cylindrical nut: N, M, Y are obtained in the tables of page 38 of the catalogue.

SHUTON advises to use the dimensions of the tables, although it is possible to manufacture ball screw with other dimensions. In brackets () second options. Smaller nut diameters than the first option of the table can reduce the rigidity of the assembly between 5 and 10%.

Please consult SHUTON.

HIGH LOADS, Single nut

Ball screw reference TSB Flanged single nut TSL Cylindrical single nut Recirculation U and B	No. Starts	Nominal diameter	Lead	Ball diameter	Root diameter	Circuits	IML Type				HDL Type			
							Dynamic load capacity [kN]	Static load capacity [kN]	Maximum recommended external force with loads CO-CO TR-TR [kN]	Maximum recommended external force with loads CO-TR [kN]	Dynamic load capacity [kN]	Static load capacity [kN]	Maximum recommended external force with loads CO-CO TR-TR [kN]	Maximum recommended external force with loads CO-TR [kN]
	$l/2$	d_0	P_h	D_w	d_2	$i (I_e)$	$C_a (kN)$	$C_{oa} (kN)$	F_{max,CO^2TR^2}	$F_{max,CO-TR}$	$C_a (kN)$	$C_{oa} (kN)$	F_{max,CO^2TR^2}	$F_{max,CO-TR}$
TS_-B 16020-15-10	1	160	20	15,875	147	10	891	3546	1250	1200	976	3980	900	870
TS_-B 16020-15-11	1	160	20	15,875	147	11	972	3930	1350	1300	1064	4410	990	950
TS_-B 16020-15-12	1	160	20	15,875	147	12	1059	4361	1450	1400	1160	4894	1100	1050
TS_-B 16020-15-13	1	160	20	15,875	147	13	1126	4672	1600	1500	1233	5244	1150	1100
TS_-B 16020-15-14	1	160	20	15,875	147	14	1200	5032	1700	1600	1314	5647	1250	1150
TS_-B 16020-15-15	1	160	20	15,875	147	15	1283	5451	1800	1650	1404	6118	1350	1250
TS_-B 16020-15-16	1	160	20	15,875	147	16	1346	5751	1900	1750	1474	6454	1400	1250
TS_-B 16020-15-17	1	160	20	15,875	147	17	1418	6110	2000	1800	1552	6857	1450	1300
TS_-B 16020-15-18	1	160	20	15,875	147	18	1500	6541	2100	1850	1643	7341	1550	1350
TS_-B 16025-19-2	1	160	25	19,05	144,1	2	298	805	330	330	335	933	220	220
TS_-B 16025-19-3	1	160	25	19,05	144,1	3	416	1268	510	510	467	1469	350	350
TS_-B 16025-19-4	1	160	25	19,05	144,1	4	534	1730	690	690	599	2005	470	470
TS_-B 16025-19-5	1	160	25	19,05	144,1	5	629	2090	840	830	706	2421	570	560
TS_-B 16025-19-6	1	160	25	19,05	144,1	6	739	2535	1000	990	830	2937	690	680
TS_-B 16025-19-7	1	160	25	19,05	144,1	7	853	3015	1200	1150	958	3493	810	790
TS_-B 16025-19-8	1	160	25	19,05	144,1	8	959	3460	1350	1300	1077	4009	920	890
TS_-B 16025-19-9	1	160	25	19,05	144,1	9	1045	3803	1500	1400	1173	4406	1000	970
TS_-B 16025-19-10	1	160	25	19,05	144,1	10	1150	4265	1650	1600	1292	4942	1150	1050
TS_-B 16025-19-11	1	160	25	19,05	144,1	11	1255	4728	1800	1700	1409	5478	1250	1150
TS_-B 16025-19-12	1	160	25	19,05	144,1	12	1358	5190	1950	1800	1525	6013	1350	1250
TS_-B 16025-19-13	1	160	25	19,05	144,1	13	1442	5550	2100	1900	1619	6430	1450	1300
TS_-B 16025-19-14	1	160	25	19,05	144,1	14	1546	6030	2250	2000	1736	6986	1500	1350
TS_-B 16025-19-15	1	160	25	19,05	144,1	15	1648	6509	2350	2050	1851	7542	1600	1400
TS_-B 16025-19-16	1	160	25	19,05	144,1	16	1738	6921	2500	2150	1952	8018	1700	1450
TS_-B 16032-25-2	1	160	32	25,4	138,7	2					503	1252	260	260
TS_-B 16032-25-3	1	160	32	25,4	138,7	3					714	2025	420	420
TS_-B 16032-25-4	1	160	32	25,4	138,7	4					915	2761	570	570
TS_-B 16032-25-5	1	160	32	25,4	138,7	5					1113	3497	710	690
TS_-B 16032-25-6	1	160	32	25,4	138,7	6					1314	4270	850	820
TS_-B 16032-25-7	1	160	32	25,4	138,7	7					1459	4785	970	930
TS_-B 16032-25-8	1	160	32	25,4	138,7	8					1646	5522	1100	1050
TS_-B 16032-25-9	1	160	32	25,4	138,7	9					1829	6258	1200	1150
TS_-B 16032-25-10	1	160	32	25,4	138,7	10					2010	6994	1350	1200
TS_-B 16032-25-11	1	160	32	25,4	138,7	11					2202	7804	1450	1300
TS_-B 16032-25-12	1	160	32	25,4	138,7	12					2377	8540	1550	1350

* C_a and C_{oa} : Modified static and dynamic load capacities, calculated according to DIN 69051/4 standard and ISO3408/5. See pages 39 and 43.

** Rb/t : Rigidity of the balls contact zone for an external force 20% of C_a . See page 46. For different forces, multiply by $\sqrt[3]{F/0,2 C_a}$

*** Rnu : Total rigidity of the complete nut. It must be multiplied by the factor f_{ar} , which depends on the manufacturing tolerance. See page 48.

**** Check with SHUTON in case higher loads or more adjusted nut dimensions are required.

***** Check external maximum axial force in the two senses.

For the indicated leads, in case C_a and C_{oa} requirements is lower, there is possibility of smaller size balls

Nut length	Nut dimensions, B-type recirculation, 8 hole design <small>*dimensions of 12 hole design check with Shuton</small>										Grease quantity TS 'steel ball'	Ball screw reference TSB Flanged single nut TSL Cylindrical single nut Recirculation U and B
	TSB	D_1	$D_{L,min}$	D_4	D_6	M	D_5	L_7	L_1	L_8		
264	230		262	294	M20	22	45	40	235	264,5	508	TS_B 16020-15-10
284	230		262	294	M20	22	45	40	235	264,5	541	TS_B 16020-15-11
304	230		262	294	M20	22	45	40	235	264,5	569	TS_B 16020-15-12
325	230		265	300	M22	24	45	40	235	267,5	610	TS_B 16020-15-13
345	230		265	300	M22	24	45	40	235	267,5	641	TS_B 16020-15-14
363	230		265	300	M22	24	45	40	235	267,5	664	TS_B 16020-15-15
384	230		265	300	M22	24	45	40	235	267,5	705	TS_B 16020-15-16
404	230		268	306	M24	26	45	40	235	270,5	736	TS_B 16020-15-17
424	230		268	306	M24	26	45	40	235	270,5	766	TS_B 16020-15-18
105	240	(235)	266 (261)	292 (287)	M16	17,5	50	40	245 (240)	268,5 (263,5)	268	TS_B 16025-19-2
130	240	(235)	266 (261)	292 (287)	M16	17,5	50	40	245 (240)	268,5 (263,5)	313	TS_B 16025-19-3
155	240	(235)	266 (261)	292 (287)	M16	17,5	50	40	245 (240)	268,5 (263,5)	357	TS_B 16025-19-4
193	240	(235)	266 (261)	292 (287)	M16	17,5	50	40	245 (240)	268,5 (263,5)	469	TS_B 16025-19-5
218	240	(235)	269 (264)	298 (293)	M18	20	50	40	245 (240)	271,5 (266,5)	516	TS_B 16025-19-6
243	240	(235)	272 (267)	304 (299)	M20	22	50	40	245 (240)	274,5 (269,5)	558	TS_B 16025-19-7
268	240	(235)	272 (267)	304 (299)	M20	22	50	40	245 (240)	274,5 (269,5)	606	TS_B 16025-19-8
297	240	(235)	272 (267)	304 (299)	M20	22	50	40	245 (240)	274,5 (269,5)	682	TS_B 16025-19-9
322	240	(235)	275 (270)	310 (305)	M22	24	50	40	245 (240)	277,5 (272,5)	721	TS_B 16025-19-10
347	240	(235)	275 (270)	310 (305)	M22	24	50	40	245 (240)	277,5 (272,5)	769	TS_B 16025-19-11
370	240	(235)	278 (273)	316 (311)	M24	26	50	40	245 (240)	280,5 (275,5)	807	TS_B 16025-19-12
397	240	(235)	278 (273)	316 (311)	M24	26	50	40	245 (240)	280,5 (275,5)	868	TS_B 16025-19-13
422	240	(235)	282 (277)	324 (319)	M27	29	50	40	245 (240)	284,5 (279,5)	915	TS_B 16025-19-14
447	240	(235)	282 (277)	324 (319)	M27	29	50	40	245 (240)	284,5 (279,5)	962	TS_B 16025-19-15
472	240	(235)	282 (277)	324 (319)	M27	29	50	40	245 (240)	284,5 (279,5)	1009	TS_B 16025-19-16
130	260	(250)	293 (283)	325 (315)	M20	22	60	40	265 (255)	295 (285)	714	TS_B 16032-25-2
162	260	(250)	293 (283)	325 (315)	M20	22	60	40	265 (255)	295 (285)	829	TS_B 16032-25-3
194	260	(250)	293 (283)	325 (315)	M20	22	60	40	265 (255)	295 (285)	944	TS_B 16032-25-4
226	260	(250)	293 (283)	325 (315)	M20	22	60	40	265 (255)	295 (285)	1076	TS_B 16032-25-5
258	260	(250)	293 (283)	325 (315)	M20	22	60	40	265 (255)	295 (285)	1199	TS_B 16032-25-6
306	260	(250)	293 (283)	325 (315)	M20	22	60	40	265 (255)	295 (285)	1470	TS_B 16032-25-7
338	260	(250)	293 (283)	325 (315)	M20	22	60	40	265 (255)	295 (285)	1593	TS_B 16032-25-8
370	260	(250)	293 (283)	325 (315)	M20	22	60	40	265 (255)	295 (285)	1733	TS_B 16032-25-9
400	260	(250)	293 (283)	325 (315)	M20	22	60	40	265 (255)	295 (285)	1839	TS_B 16032-25-10
432	260	(250)	293 (283)	325 (315)	M20	22	60	40	265 (255)	295 (285)	1945	TS_B 16032-25-11
464	260	(250)	296 (286)	331 (321)	M22	24	60	40	265 (255)	298 (288)	2086	TS_B 16032-25-12

Key dimensions of the cylindrical nut: N, M, Y are obtained in the tables of page 38 of the catalogue.

SHUTON advises to use the dimensions of the tables, although it is possible to manufacture ball screw with other dimensions. In brackets () second options. Smaller nut diameters than the first option of the table can reduce the rigidity of the assembly between 5 and 10%.

Please consult SHUTON.

SHUTON
ATR

High efficiency precision ball screws for pick and place applications, factory automation, actuators and other transport applications.







S-type recirculation system

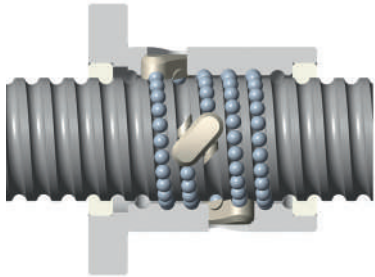

U-type recirculation system

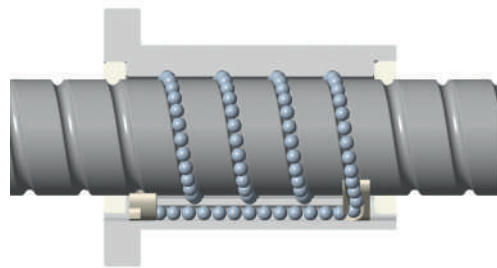

Types of ATR nuts depending on application:

Technology	Sectors	Features	Preload	Nut type	Recirc.	Diameter	Lead	Ball size	Application
ATR	Machine tool Injection machine Semiconductor Elevators Actuators Automatization	Precision transportation ball screws	NO	TS Single Nut	S	20-100	5-20	3-9	General transportation application
					U	25-100	10-80	5-11	General transportation application, higher speed and load requirement

ATR Single Nut

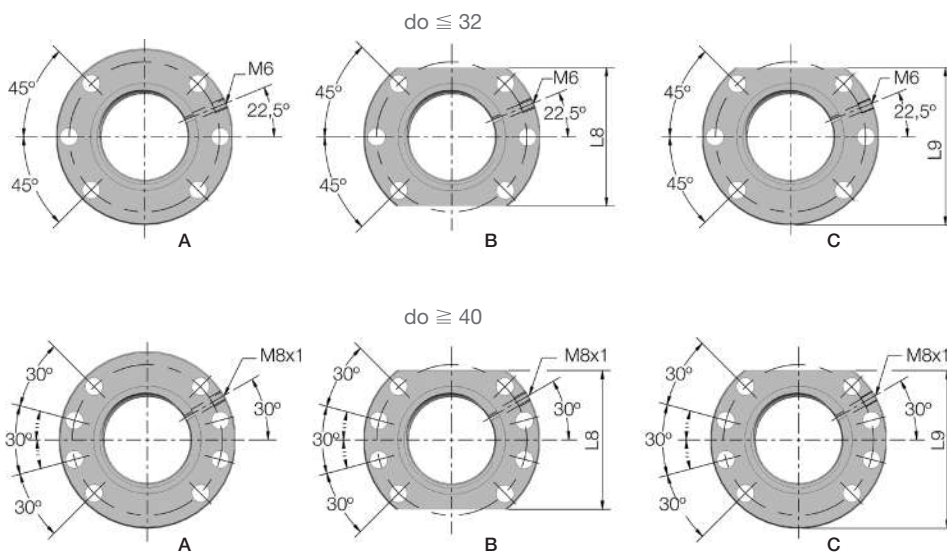
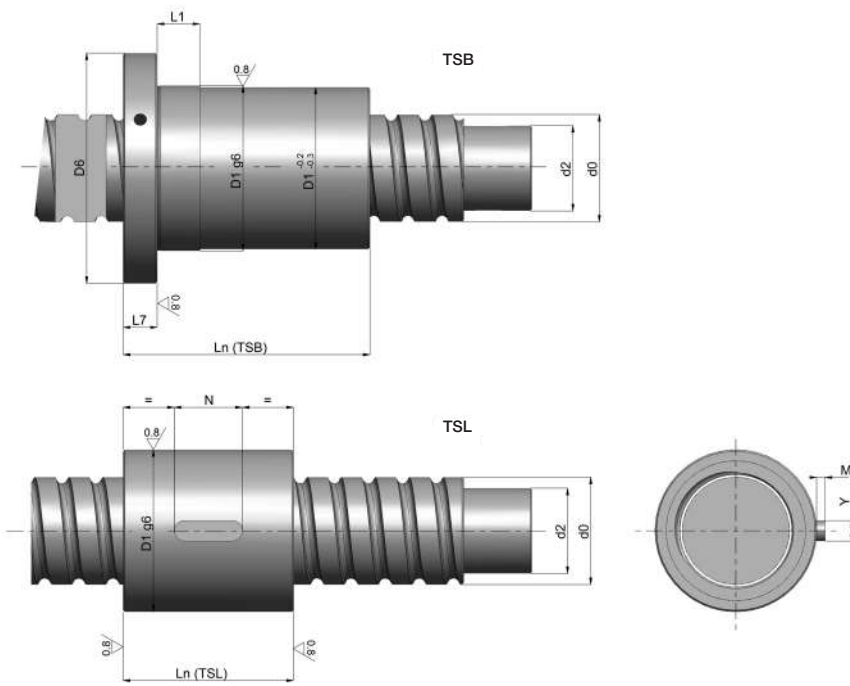

ATR, Single Nut

Ball screw reference	Nominal diameter	Lead	Ball diameter	Root diameter	Circuits	Dynamic load capacity	Static load capacity [kN]	Rigidity of ball contact zone	Rigidity of nut, with $F_{ext}:20\%C_a$	Nut length	
										d_0	P_h
TSB Flanged single nut TSL Cylindrical single nut Recirculation S and U	d_0	P_h	D_w	d_2	$i (le)$	$C_a (N)$	$C_{oa} (N)$	$R_{b/t} (N/\mu m)$	$R_{nut} (N/\mu m)$	TSB	TSL
TS-S 2005-3-2	20	5	3,175	17,8	2	8200	11900	250	230	40	36
TS-S 2005-3-3	20	5	3,175	17,8	3	11000	17900	360	330	46	41
TS-S 2005-3-4	20	5	3,175	17,8	4	13900	23900	470	430	51	47
TS-S 2005-3-5	20	5	3,175	17,8	5	16800	29900	580	540	56	52
TS-S 2005-3-6	20	5	3,175	17,8	6	19600	35800	690	640	61	57
TS-S 2505-3-2	25	5	3,175	22,8	2	9300	15700	310	270	40	36
TS-S 2505-3-3	25	5	3,175	22,8	3	12600	23500	450	400	46	42
TS-S 2505-3-4	25	5	3,175	22,8	4	15900	31300	590	520	51	47
TS-S 2505-3-5	25	5	3,175	22,8	5	19200	39200	730	650	56	52
TS-S 2505-3-6	25	5	3,175	22,8	6	22400	47000	870	770	61	57
TS-S 2510-5-2	25	10	4,762	21,7	2	16000	23300	320	290	55	53
TS-S 2510-5-3	25	10	4,762	21,7	3	21700	34900	460	430	67	64
TS-S 2510-5-4	25	10	4,762	21,7	4	27400	46500	600	560	79	76
TS-U 2510-5-2	25	10	4,762	21,7	2	16400	24100	330	310	49	49
TS-U 2510-5-3	25	10	4,762	21,7	3	23400	39100	510	480	59	59
TS-U 2510-5-4	25	10	4,762	21,7	4	29900	53200	670	640	69	69
TS-U 2510-5-5	25	10	4,762	21,7	5	36700	68100	850	800	79	79
TS-U 2512-5-2	25	12	4,762	21,7	2	16400	24000	330	310	53	53
TS-U 2512-5-3	25	12	4,762	21,7	3	23300	38900	510	480	65	65
TS-U 2512-5-4	25	12	4,762	21,7	4	29800	53000	670	640	77	77
TS-U 2515-5-2	25	15	4,762	21,7	2	16200	23900	320	310	58	58
TS-U 2515-5-3	25	15	4,762	21,7	3	23100	38700	500	480	73	73
TS-U 2516-5-2	25	16	4,762	21,7	2	16200	23800	320	310	60	60
TS-U 2516-5-3	25	16	4,762	21,7	3	23000	38600	500	480	72	72
TS-U 2520-5-2	25	20	4,762	21,7	2	16400	24400	320	310	67	67
TS-U 2525-5-2	25	25	4,762	21,7	2	16000	24100	310	310	75	75
TS-S 3205-3-2	32	5	3,175	29,8	2	10600	20900	400	340	42	36
TS-S 3205-3-3	32	5	3,175	29,8	3	14300	31300	570	490	48	42
TS-S 3205-3-4	32	5	3,175	29,8	4	18100	41800	750	650	53	47
TS-S 3205-3-5	32	5	3,175	29,8	5	21800	52200	930	800	58	52
TS-S 3205-3-6	32	5	3,175	29,8	6	25500	62700	1100	950	63	58
TS-S 3205-3-7	32	5	3,175	29,8	7	29100	73100	1280	1100	68	62
TS-S 3205-3-8	32	5	3,175	29,8	8	32600	83500	1450	1250	74	68
TS-S 3206-4-2	32	6	3,969	29,2	2	15100	27300	420	360	45	39
TS-S 3206-4-3	32	6	3,969	29,2	3	20300	41000	610	530	52	46
TS-S 3206-4-4	32	6	3,969	29,2	4	25700	54600	800	690	59	53
TS-S 3206-4-5	32	6	3,969	29,2	5	31000	68300	980	860	65	59
TS-S 3206-4-6	32	6	3,969	29,2	6	36100	82000	1170	1020	72	65
TS-S 3210-6-2	32	10	6,35	27,6	2	24700	36300	370	340	66	64
TS-S 3210-6-3	32	10	6,35	27,6	3	33300	54500	540	490	79	75

* C_a and C_{oa} : Modified static and dynamic load capacities, calculated according to DIN 69051/4 standard and ISO3408/5. See pages 39 and 43.

** $R_{b/t}$: Rigidity of the balls contact zone for an external force 20% of C_a . See page 46. For different forces, multiply by $\sqrt[3]{F/0,2 C_a}$

*** R_{nu} : Total rigidity of the complete nut. It must be multiplied by the factor f_{ar} , which depends on the manufacturing tolerance. See page 48.

Nut dimensions										Grease quantity TS 'steel ball'	Ball screw reference
$D_{1, std}$	$D_{1, min}$	D_4	D_6	M	D_5	L_7	L_1	L_8	L_9	$Q_{gr, real, TS} (cm^3)$	TSB Flanged single nut TSL Cylindrical single nut Recirculation S and U
36		47	58	M6	6,6	10	10	44	51	2,1	TS_-S 2005-3-2
36		47	58	M6	6,6	10	10	44	51	2,5	TS_-S 2005-3-3
36		47	58	M6	6,6	10	10	44	51	2,7	TS_-S 2005-3-4
36		47	58	M6	6,6	10	10	44	51	3	TS_-S 2005-3-5
36		47	58	M6	6,6	10	10	44	51	3,3	TS_-S 2005-3-6
40		51	62	M6	6,6	10	10	48	55	2,6	TS_-S 2505-3-2
40		51	62	M6	6,6	10	10	48	55	3	TS_-S 2505-3-3
40		51	62	M6	6,6	10	10	48	55	3,3	TS_-S 2505-3-4
40		51	62	M6	6,6	10	10	48	55	3,7	TS_-S 2505-3-5
40		51	62	M6	6,6	10	10	48	55	4	TS_-S 2505-3-6
40		51	62	M6	6,6	10	16	48	55	4,8	TS_-S 2510-5-2
40		51	62	M6	6,6	10	16	48	55	6,1	TS_-S 2510-5-3
40		51	62	M6	6,6	10	16	48	55	7,3	TS_-S 2510-5-4
50	(45)	65 (58)	80 (71)	M8	9	10	16	62 (55)	71 (63)	3,9	TS_-U 2510-5-2
50	(45)	65 (58)	80 (71)	M8	9	10	16	62 (55)	71 (63)	4,7	TS_-U 2510-5-3
50	(45)	65 (58)	80 (71)	M8	9	10	16	62 (55)	71 (63)	5,6	TS_-U 2510-5-4
50	(45)	65 (58)	80 (71)	M8	9	10	16	62 (55)	71 (63)	6,5	TS_-U 2510-5-5
50	(45)	65 (58)	80 (71)	M8	9	10	16	62 (55)	71 (63)	4,1	TS_-U 2512-5-2
50	(45)	65 (58)	80 (71)	M8	9	10	16	62 (55)	71 (63)	5,1	TS_-U 2512-5-3
50	(45)	65 (58)	80 (71)	M8	9	10	16	62 (55)	71 (63)	6,2	TS_-U 2512-5-4
50	(45)	65 (58)	80 (71)	M8	9	10	16	62 (55)	71 (63)	4,4	TS_-U 2515-5-2
50	(45)	65 (58)	80 (71)	M8	9	10	16	62 (55)	71 (63)	5,7	TS_-U 2515-5-3
50	(45)	65 (58)	80 (71)	M8	9	10	16	62 (55)	71 (63)	4,5	TS_-U 2516-5-2
50	(45)	65 (58)	80 (71)	M8	9	10	16	62 (55)	71 (63)	5,4	TS_-U 2516-5-3
50	(45)	65 (58)	80 (71)	M8	9	10	16	62 (55)	71 (63)	5	TS_-U 2520-5-2
50	(45)	65 (58)	80 (71)	M8	9	10	16	62 (55)	71 (63)	5,6	TS_-U 2525-5-2
50		65	80	M8	9	12	10	62	71	3,5	TS_-S 3205-3-2
50		65	80	M8	9	12	10	62	71	4,1	TS_-S 3205-3-3
50		65	80	M8	9	12	10	62	71	4,5	TS_-S 3205-3-4
50		65	80	M8	9	12	10	62	71	4,8	TS_-S 3205-3-5
50		65	80	M8	9	12	10	62	71	5,4	TS_-S 3205-3-6
50		65	80	M8	9	12	10	62	71	5,6	TS_-S 3205-3-7
50		65	80	M8	9	12	10	62	71	6,1	TS_-S 3205-3-8
50		65	80	M8	9	12	10	62	71	4,9	TS_-S 3206-4-2
50		65	80	M8	9	12	10	62	71	5,6	TS_-S 3206-4-3
50		65	80	M8	9	12	10	62	71	6,4	TS_-S 3206-4-4
50		65	80	M8	9	12	10	62	71	6,9	TS_-S 3206-4-5
50		65	80	M8	9	12	10	62	71	7,7	TS_-S 3206-4-6
50		65	80	M8	9	14	16	62	71	11	TS_-S 3210-6-2
50		65	80	M8	9	14	16	62	71	14	TS_-S 3210-6-3

Key dimensions of the cylindrical nut: N, M, Y are obtained in the tables of page 38 of the catalogue.

SHUTON advises to use the dimensions of the tables, although it is possible to manufacture ball screw with other dimensions. In brackets () second options. Smaller nut diameters than the first option of the table can reduce the rigidity of the assembly between 5 and 10%.

Please consult SHUTON.

ATR, Single Nut

Ball screw reference	Nominal diameter	Lead	Ball diameter	Root diameter	Circuits	Dynamic load capacity	Static load capacity [kN]	Rigidity of ball contact zone	Rigidity of nut, with $F_{ext}:20\%C_a$	Nut length	
										d_0	P_h
TSB Flanged single nut TSL Cylindrical single nut Recirculation S and U	d_0	P_h	D_w	d_2	$i (le)$	$C_a (N)$	$C_{oa} (N)$	$R_{b/t} (N/\mu m)$	$R_{nut} (N/\mu m)$	TSB	TSL
TS_S 3210-6-4	32	10	6,35	27,6	4	42100	72700	710	650	87	86
TS_S 3210-6-5	32	10	6,35	27,6	5	50800	90800	870	800	101	97
TS_S 3210-6-6	32	10	6,35	27,6	6	59300	109000	1040	950	111	107
TS_U 3210-6-2	32	10	6,35	26,5	2	26800	40200	430	400	54	54
TS_U 3210-6-3	32	10	6,35	26,5	3	38600	66600	680	640	64	64
TS_U 3210-6-4	32	10	6,35	26,5	4	49800	91300	920	860	74	74
TS_U 3210-6-5	32	10	6,35	26,5	5	61200	117600	1160	1080	84	84
TS_U 3210-6-6	32	10	6,35	26,5	6	71800	142400	1370	1270	94	94
TS_U 3212-6-2	32	12	6,35	26,5	2	26700	40200	430	410	58	58
TS_U 3212-6-3	32	12	6,35	26,5	3	38500	66400	680	640	70	70
TS_U 3212-6-4	32	12	6,35	26,5	4	49600	91100	920	860	82	82
TS_U 3212-6-5	32	12	6,35	26,5	5	61000	117400	1150	1090	94	94
TS_U 3212-6-6	32	12	6,35	26,5	6	71600	142100	1360	1280	106	106
TS_U 3215-6-2	32	15	6,35	26,5	2	27300	41600	440	420	63	63
TS_U 3215-6-3	32	15	6,35	26,5	3	38300	66200	680	640	78	78
TS_U 3215-6-4	32	15	6,35	26,5	4	49900	92300	920	880	93	93
TS_U 3216-6-2	32	16	6,35	26,5	2	27200	41500	440	420	64	64
TS_U 3216-6-3	32	16	6,35	26,5	3	38300	66100	670	640	80	80
TS_U 3216-6-4	32	16	6,35	26,5	4	49900	92200	920	880	96	96
TS_U 3220-6-2	32	20	6,35	26,5	2	27000	41200	430	420	71	71
TS_U 3220-6-3	32	20	6,35	26,5	3	38000	65700	660	640	91	91
TS_U 3225-6-2	32	25	6,35	26,5	2	26700	40800	420	410	83	81
TS_U 3225-6-3	32	25	6,35	26,5	3	38000	66500	660	650	106	106
TS_U 3232-6-2	32	32	6,35	26,5	2	26700	41600	420	410	94	94
TS_S 4005-3-2	40	5	3,175	37,8	2	11800	26900	480	400	44	36
TS_S 4005-3-3	40	5	3,175	37,8	3	16000	40300	700	590	50	42
TS_S 4005-3-4	40	5	3,175	37,8	4	20200	53700	920	780	55	47
TS_S 4005-3-5	40	5	3,175	37,8	5	24300	67200	1140	960	60	52
TS_S 4005-3-6	40	5	3,175	37,8	6	28400	80600	1350	1140	65	57
TS_S 4006-4-2	40	6	3,969	37,2	2	16700	34800	510	430	47	39
TS_S 4006-4-3	40	6	3,969	37,2	3	22600	52200	740	630	54	46
TS_S 4006-4-4	40	6	3,969	37,2	4	28600	69600	970	830	62	53
TS_S 4006-4-5	40	6	3,969	37,2	5	34400	87000	1200	1030	67	59
TS_S 4006-4-6	40	6	3,969	37,2	6	40200	104400	1420	1220	73	65
TS_S 4008-5-2	40	8	4,762	36,7	2	21400	41200	510	450	56	50
TS_S 4008-5-3	40	8	4,762	36,7	3	28900	61800	750	650	66	59
TS_S 4008-5-4	40	8	4,762	36,7	4	36500	82500	980	860	74	68
TS_S 4008-5-5	40	8	4,762	36,7	5	44000	103100	1200	1060	82	76
TS_S 4008-5-6	40	8	4,762	36,7	6	51300	123700	1430	1260	91	85
TS_S 4010-6-2	40	10	6,35	35,6	2	28700	48300	480	430	68	64

* C_a and C_{oa} : Modified static and dynamic load capacities, calculated according to DIN 69051/4 standard and ISO3408/5. See pages 39 and 43.

** $R_{b/t}$: Rigidity of the balls contact zone for an external force 20% of C_a . See page 46. For different forces, multiply by $\sqrt[3]{F/0,2 C_a}$

*** R_{nu} : Total rigidity of the complete nut. It must be multiplied by the factor f_{ar} , which depends on the manufacturing tolerance. See page 48.

Nut dimensions										Grease quantity TS 'steel ball'	Ball screw reference
$D_{1, std}$	$D_{1, min}$	D_4	D_6	M	D_5	L_7	L_1	L_8	L_9	$Q_{gr, real, TS} (cm^3)$	TSB Flanged single nut TSL Cylindrical single nut Recirculation S and U
50		65	80	M8	9	14	16	62	71	15	TS_-S 3210-6-4
50		65	80	M8	9	14	16	62	71	18	TS_-S 3210-6-5
50		65	80	M8	9	14	16	62	71	19	TS_-S 3210-6-6
56		71	86	M8	9	14	20	65	75,5	6,3	TS_-U 3210-6-2
56		71	86	M8	9	14	20	65	75,5	7,3	TS_-U 3210-6-3
56		71	86	M8	9	14	20	65	75,5	8,4	TS_-U 3210-6-4
56		71	86	M8	9	14	20	65	75,5	9,6	TS_-U 3210-6-5
56		71	86	M8	9	14	20	65	75,5	11	TS_-U 3210-6-6
56		71	86	M8	9	14	20	65	75,5	6,1	TS_-U 3212-6-2
56		71	86	M8	9	14	20	65	75,5	7,3	TS_-U 3212-6-3
56		71	86	M8	9	14	20	65	75,5	8,6	TS_-U 3212-6-4
56		71	86	M8	9	14	20	65	75,5	9,9	TS_-U 3212-6-5
56		71	86	M8	9	14	20	65	75,5	11	TS_-U 3212-6-6
56		71	86	M8	9	14	20	65	75,5	5,9	TS_-U 3215-6-2
56		71	86	M8	9	14	20	65	75,5	7,4	TS_-U 3215-6-3
56		71	86	M8	9	14	20	65	75,5	8,8	TS_-U 3215-6-4
56		71	86	M8	9	14	20	65	75,5	5,7	TS_-U 3216-6-2
56		71	86	M8	9	14	20	65	75,5	7,3	TS_-U 3216-6-3
56		71	86	M8	9	14	20	65	75,5	8,8	TS_-U 3216-6-4
56		71	86	M8	9	14	20	65	75,5	5,9	TS_-U 3220-6-2
56		71	86	M8	9	14	20	65	75,5	7,8	TS_-U 3220-6-3
56		71	86	M8	9	14	20	65	75,5	6,7	TS_-U 3225-6-2
56		71	86	M8	9	14	20	65	75,5	8,3	TS_-U 3225-6-3
56		71	86	M8	9	14	20	65	75,5	6,6	TS_-U 3232-6-2
63		78	93	M8	9	14	10	70	81,5	4,7	TS_-S 4005-3-2
63		78	93	M8	9	14	10	70	81,5	5,4	TS_-S 4005-3-3
63		78	93	M8	9	14	10	70	81,5	5,8	TS_-S 4005-3-4
63		78	93	M8	9	14	10	70	81,5	6,3	TS_-S 4005-3-5
63		78	93	M8	9	14	10	70	81,5	6,7	TS_-S 4005-3-6
63		78	93	M8	9	14	10	70	81,5	6,4	TS_-S 4006-4-2
63		78	93	M8	9	14	10	70	81,5	7,4	TS_-S 4006-4-3
63		78	93	M8	9	14	10	70	81,5	8,5	TS_-S 4006-4-4
63		78	93	M8	9	14	10	70	81,5	9	TS_-S 4006-4-5
63		78	93	M8	9	14	10	70	81,5	9,9	TS_-S 4006-4-6
63		78	93	M8	9	14	10	70	81,5	8,4	TS_-S 4008-5-2
63		78	93	M8	9	14	10	70	81,5	10	TS_-S 4008-5-3
63		78	93	M8	9	14	10	70	81,5	11	TS_-S 4008-5-4
63		78	93	M8	9	14	10	70	81,5	12	TS_-S 4008-5-5
63		78	93	M8	9	14	10	70	81,5	14	TS_-S 4008-5-6
63		78	93	M8	9	14	16	70	81,5	14	TS_-S 4010-6-2

Key dimensions of the cylindrical nut: N, M, Y are obtained in the tables of page 38 of the catalogue.

SHUTON advises to use the dimensions of the tables, although it is possible to manufacture ball screw with other dimensions. In brackets () second options. Smaller nut diameters than the first option of the table can reduce the rigidity of the assembly between 5 and 10%.

Please consult SHUTON.

ATR, Single Nut

Ball screw reference	Nominal diameter	Lead	Ball diameter	Root diameter	Circuits	Dynamic load capacity	Static load capacity [kN]	Rigidity of ball contact zone	Rigidity of nut, with $F_{ext}:20\%C_a$	Nut length	
										d_0	P_h
TSB Flanged single nut TSL Cylindrical single nut Recirculation S and U	d_0	P_h	D_w	d_2	$i (1e)$	$C_a (N)$	$C_{oa} (N)$	$R_{b/t} (N/\mu m)$	$R_{nut} (N/\mu m)$	TSB	TSL
TS_S 4010-6-3	40	10	6,35	35,6	3	38800	72500	690	620	79	75
TS_S 4010-6-4	40	10	6,35	35,6	4	49000	96700	900	820	90	86
TS_S 4010-6-5	40	10	6,35	35,6	5	59100	120800	1120	1010	99	97
TS_S 4010-6-6	40	10	6,35	35,6	6	68900	145000	1330	1200	111	107
TS_S 4010-6-7	40	10	6,35	35,6	7	78600	169100	1540	1390	121	117
TS_S 4010-6-8	40	10	6,35	35,6	8	88100	193300	1750	1580	132	128
TS_S 4012-6-2	40	12	6,35	35,6	2	28700	48300	480	430	69	65
TS_S 4012-6-3	40	12	6,35	35,6	3	38700	72400	690	630	83	79
TS_S 4012-6-4	40	12	6,35	35,6	4	48900	96500	900	830	96	92
TS_S 4012-6-5	40	12	6,35	35,6	5	59000	120700	1110	1020	109	105
TS_S 4012-6-6	40	12	6,35	35,6	6	68800	144800	1320	1220	121	117
TS_S 4016-6-2	40	16	6,35	35,6	2	28600	48100	470	440	81	75
TS_S 4016-6-3	40	16	6,35	35,6	3	38600	72200	680	640	100	94
TS_S 4016-6-4	40	16	6,35	35,6	4	48700	96200	900	840	117	111
TS_S 4016-6-5	40	16	6,35	35,6	5	58700	120300	1110	1040	134	128
TS_S 4020-6-2	40	20	6,35	35,6	2	29500	50700	490	470	89	82
TS_S 4020-6-3	40	20	6,35	35,6	3	39900	76100	720	680	112	105
TS_S 4020-6-4	40	20	6,35	35,6	4	50400	101500	940	890	136	128
TS_U 4010-6-2	40	10	6,35	34,5	2	31100	53600	550	500	55	55
TS_U 4010-6-3	40	10	6,35	34,5	3	44200	86600	840	760	65	65
TS_U 4010-6-4	40	10	6,35	34,5	4	56700	118100	1130	1020	75	75
TS_U 4010-6-5	40	10	6,35	34,5	5	69000	149600	1400	1270	85	85
TS_U 4010-6-6	40	10	6,35	34,5	6	81400	182700	1670	1520	95	95
TS_U 4010-6-7	40	10	6,35	34,5	7	93100	214200	1920	1750	105	105
TS_U 4010-6-8	40	10	6,35	34,5	8	104600	245700	2160	1960	115	115
TS_U 4012-6-2	40	12	6,35	34,5	2	31100	53500	550	510	58	58
TS_U 4012-6-3	40	12	6,35	34,5	3	44100	86500	840	770	70	70
TS_U 4012-6-4	40	12	6,35	34,5	4	56600	118000	1130	1040	82	82
TS_U 4012-6-5	40	12	6,35	34,5	5	68800	149400	1390	1280	94	94
TS_U 4012-6-6	40	12	6,35	34,5	6	81300	182500	1670	1540	106	106
TS_U 4012-6-7	40	12	6,35	34,5	7	93000	213900	1920	1770	118	118
TS_U 4012-6-8	40	12	6,35	34,5	8	104900	247000	2170	2000	130	130
TS_U 4015-6-2	40	15	6,35	34,5	2	31000	53400	550	510	64	64
TS_U 4015-6-3	40	15	6,35	34,5	3	44000	86300	840	790	79	79
TS_U 4015-6-4	40	15	6,35	34,5	4	56400	117700	1120	1050	94	94
TS_U 4015-6-5	40	15	6,35	34,5	5	69100	150600	1400	1310	109	109
TS_U 4015-6-6	40	15	6,35	34,5	6	81000	182000	1660	1560	124	124
TS_U 4015-6-7	40	15	6,35	34,5	7	92700	213400	1910	1800	139	139
TS_U 4016-6-2	40	16	6,35	34,5	2	30900	53300	540	510	65	65
TS_U 4016-6-3	40	16	6,35	34,5	3	43900	86200	830	790	81	81

* C_a and C_{oa} : Modified static and dynamic load capacities, calculated according to DIN 69051/4 standard and ISO3408/5. See pages 39 and 43.

** $R_{b/t}$: Rigidity of the balls contact zone for an external force 20% of C_a . See page 46. For different forces, multiply by $\sqrt[3]{F/0,2 C_a}$

*** R_{nu} : Total rigidity of the complete nut. It must be multiplied by the factor f_{ar} , which depends on the manufacturing tolerance. See page 48.

Nut dimensions										Grease quantity TS 'steel ball'	Ball screw reference
$D_{1, std}$	$D_{1, min}$	D_4	D_6	M	D_5	L_7	L_1	L_8	L_9	$Q_{gr, real, TS} (cm^3)$	TSB Flanged single nut TSL Cylindrical single nut Recirculation S and U
63		78	93	M8	9	14	16	70	81,5	16	TS_-S 4010-6-3
63		78	93	M8	9	14	16	70	81,5	19	TS_-S 4010-6-4
63		78	93	M8	9	14	16	70	81,5	21	TS_-S 4010-6-5
63		78	93	M8	9	14	16	70	81,5	23	TS_-S 4010-6-6
63		78	93	M8	9	14	16	70	81,5	25	TS_-S 4010-6-7
63		78	93	M8	9	14	16	70	81,5	28	TS_-S 4010-6-8
63		78	93	M8	9	14	20	70	81,5	13	TS_-S 4012-6-2
63		78	93	M8	9	14	20	70	81,5	16	TS_-S 4012-6-3
63		78	93	M8	9	14	20	70	81,5	19	TS_-S 4012-6-4
63		78	93	M8	9	14	20	70	81,5	22	TS_-S 4012-6-5
63		78	93	M8	9	14	20	70	81,5	24	TS_-S 4012-6-6
63		78	93	M8	9	16	20	70	81,5	15	TS_-S 4016-6-2
63		78	93	M8	9	16	20	70	81,5	19	TS_-S 4016-6-3
63		78	93	M8	9	16	20	70	81,5	22	TS_-S 4016-6-4
63		78	93	M8	9	16	20	70	81,5	26	TS_-S 4016-6-5
63		78	93	M8	9	18	20	70	81,5	16	TS_-S 4020-6-2
63		78	93	M8	9	18	20	70	81,5	20	TS_-S 4020-6-3
63		78	93	M8	9	18	20	70	81,5	25	TS_-S 4020-6-4
63		78	93	M8	9	14	16	70	81,5	7,9	TS_-U 4010-6-2
63		78	93	M8	9	14	16	70	81,5	9,3	TS_-U 4010-6-3
63		78	93	M8	9	14	16	70	81,5	11	TS_-U 4010-6-4
63		78	93	M8	9	14	16	70	81,5	12	TS_-U 4010-6-5
63		78	93	M8	9	14	16	70	81,5	14	TS_-U 4010-6-6
63		78	93	M8	9	14	16	70	81,5	15	TS_-U 4010-6-7
63		78	93	M8	9	14	16	70	81,5	17	TS_-U 4010-6-8
63		78	93	M8	9	14	20	70	81,5	7,4	TS_-U 4012-6-2
63		78	93	M8	9	14	20	70	81,5	9	TS_-U 4012-6-3
63		78	93	M8	9	14	20	70	81,5	11	TS_-U 4012-6-4
63		78	93	M8	9	14	20	70	81,5	12	TS_-U 4012-6-5
63		78	93	M8	9	14	20	70	81,5	14	TS_-U 4012-6-6
63		78	93	M8	9	14	20	70	81,5	16	TS_-U 4012-6-7
63		78	93	M8	9	14	20	70	81,5	18	TS_-U 4012-6-8
65	(63)	78	93	M8	9	16	20	70	81,5	7,4	TS_-U 4015-6-2
65	(63)	78	93	M8	9	16	20	70	81,5	9,2	TS_-U 4015-6-3
65	(63)	78	93	M8	9	16	20	70	81,5	11	TS_-U 4015-6-4
65	(63)	78	93	M8	9	16	20	70	81,5	13	TS_-U 4015-6-5
65	(63)	78	93	M8	9	16	20	70	81,5	15	TS_-U 4015-6-6
65	(63)	78	93	M8	9	16	20	70	81,5	17	TS_-U 4015-6-7
65	(63)	78	93	M8	9	16	20	70	81,5	7,3	TS_-U 4016-6-2
65	(63)	78	93	M8	9	16	20	70	81,5	9,2	TS_-U 4016-6-3

Key dimensions of the cylindrical nut: N, M, Y are obtained in the tables of page 38 of the catalogue.

SHUTON advises to use the dimensions of the tables, although it is possible to manufacture ball screw with other dimensions. In brackets () second options. Smaller nut diameters than the first option of the table can reduce the rigidity of the assembly between 5 and 10%.

Please consult SHUTON.

ATR, Single Nut

Ball screw reference	Nominal diameter	Lead	Ball diameter	Root diameter	Circuits	Dynamic load capacity	Static load capacity [kN]	Rigidity of ball contact zone	Rigidity of nut, with $F_{ext}:20\%C_a$	Nut length	
TSB Flanged single nut TSL Cylindrical single nut Recirculation S and U	d_0	P_h	D_w	d_2	$i (le)$	$C_a (N)$	$C_{oa} (N)$	$R_{b/t} (N/\mu m)$	$R_{nut} (N/\mu m)$	TSB	TSL
TS-U 4016-6-4	40	16	6,35	34,5	4	56400	117600	1120	1060	97	97
TS-U 4016-6-5	40	16	6,35	34,5	5	69000	150500	1400	1320	113	113
TS-U 4016-6-6	40	16	6,35	34,5	6	80900	181900	1660	1560	129	129
TS-U 4020-6-2	40	20	6,35	34,5	2	31400	54600	550	530	72	72
TS-U 4020-6-3	40	20	6,35	34,5	3	43700	85900	830	790	92	92
TS-U 4020-6-4	40	20	6,35	34,5	4	56600	118600	1130	1070	112	112
TS-U 4020-6-5	40	20	6,35	34,5	5	68600	149900	1380	1320	132	132
TS-U 4025-6-2	40	25	6,35	34,5	2	31100	54300	550	530	81	81
TS-U 4025-6-3	40	25	6,35	34,5	3	43900	86800	830	800	106	106
TS-U 4025-6-4	40	25	6,35	34,5	4	56100	117900	1110	1070	131	131
TS-U 4030-6-2	40	30	6,35	34,5	2	30800	53900	540	520	89	89
TS-U 4030-6-3	40	30	6,35	34,5	3	43400	86200	820	790	119	119
TS-U 4040-6-2	40	40	6,35	34,5	2	30600	54300	530	520	109	109
TS-U 4050-6-2	40	50	6,35	34,5	2	30200	54500	520	510	124	124
TS-U 4060-6-2	40	60	6,35	34,5	2	29600	54400	500	490	142	142
TS-U 4015-8-2	40	15	7,938	33,3	2	43200	70500	620	590	69	69
TS-U 4015-8-3	40	15	7,938	33,3	3	60800	112200	940	900	84	84
TS-U 4015-8-4	40	15	7,938	33,3	4	79100	156600	1290	1220	99	99
TS-U 4015-8-5	40	15	7,938	33,3	5	96200	198400	1600	1520	114	114
TS-U 4015-8-6	40	15	7,938	33,3	6	113700	242700	1910	1810	129	129
TS-U 4016-8-2	40	16	7,938	33,3	2	43200	70400	620	590	71	71
TS-U 4016-8-3	40	16	7,938	33,3	3	60700	112100	940	900	87	87
TS-U 4016-8-4	40	16	7,938	33,3	4	79000	156500	1290	1220	103	103
TS-U 4016-8-5	40	16	7,938	33,3	5	96100	198200	1600	1520	119	119
TS-U 4016-8-6	40	16	7,938	33,3	6	113600	242500	1910	1810	135	135
TS-U 4020-8-2	40	20	7,938	33,3	2	42900	70100	610	590	77	77
TS-U 4020-8-3	40	20	7,938	33,3	3	60400	111700	930	900	97	97
TS-U 4020-8-4	40	20	7,938	33,3	4	78600	155800	1280	1230	117	117
TS-U 4020-8-5	40	20	7,938	33,3	5	96400	200000	1600	1540	137	137
TS-U 4025-8-2	40	25	7,938	33,3	2	42600	69700	600	580	87	87
TS-U 4025-8-3	40	25	7,938	33,3	3	60800	113500	940	910	112	112
TS-U 4025-8-4	40	25	7,938	33,3	4	78000	154800	1260	1220	137	137
TS-U 4030-8-2	40	30	7,938	33,3	2	42200	69100	590	580	94	94
TS-U 4030-8-3	40	30	7,938	33,3	3	60200	112700	930	900	124	124
TS-U 4040-8-2	40	40	7,938	33,3	2	42100	70300	590	580	112	112
TS-U 4050-8-2	40	50	7,938	33,3	2	41800	71100	580	570	123	123
TS-U 4060-8-2	40	60	7,938	33,3	2	41300	71600	560	560	140	140
TS-S 5005-3-2	50	5	3,175	47,8	2	13100	34300	590	470	46	36
TS-S 5005-3-3	50	5	3,175	47,8	3	17700	51500	860	690	52	42
TS-S 5005-3-4	50	5	3,175	47,8	4	22300	68700	1120	900	57	47

* C_a and C_{oa} : Modified static and dynamic load capacities, calculated according to DIN 69051/4 standard and ISO3408/5. See pages 39 and 43.

** $R_{b/t}$: Rigidity of the balls contact zone for an external force 20% of C_a . See page 46. For different forces, multiply by $\sqrt[3]{F/0,2 C_a}$

*** R_{nu} : Total rigidity of the complete nut. It must be multiplied by the factor f_{ar} , which depends on the manufacturing tolerance. See page 48.

Nut dimensions										Grease quantity TS 'steel ball'	Ball screw reference
$D_{1, std}$	$D_{1, min}$	D_4	D_6	M	D_5	L_7	L_1	L_8	L_9	$Q_{gr, real, TS} (cm^3)$	TSB Flanged single nut TSL Cylindrical single nut Recirculation S and U
65	(63)	78	93	M8	9	16	20	70	81,5	11	TS_-U 4016-6-4
65	(63)	78	93	M8	9	16	20	70	81,5	13	TS_-U 4016-6-5
65	(63)	78	93	M8	9	16	20	70	81,5	15	TS_-U 4016-6-6
65	(63)	78	93	M8	9	18	20	70	81,5	7,3	TS_-U 4020-6-2
65	(63)	78	93	M8	9	18	20	70	81,5	9,7	TS_-U 4020-6-3
65	(63)	78	93	M8	9	18	20	70	81,5	12	TS_-U 4020-6-4
65	(63)	78	93	M8	9	18	20	70	81,5	14	TS_-U 4020-6-5
65	(63)	78	93	M8	9	18	20	70	81,5	7,8	TS_-U 4025-6-2
65	(63)	78	93	M8	9	18	20	70	81,5	10	TS_-U 4025-6-3
65	(63)	78	93	M8	9	18	20	70	81,5	13	TS_-U 4025-6-4
65	(63)	78	93	M8	9	18	20	70	81,5	8,2	TS_-U 4030-6-2
65	(63)	78	93	M8	9	18	20	70	81,5	11	TS_-U 4030-6-3
65	(63)	78	93	M8	9	18	20	70	81,5	9,3	TS_-U 4040-6-2
65	(63)	78	93	M8	9	18	20	70	81,5	10	TS_-U 4050-6-2
65	(63)	78	93	M8	9	18	20	70	81,5	12	TS_-U 4060-6-2
70		85	100	M8	9	18	25	75	87,5	11	TS_-U 4015-8-2
70		85	100	M8	9	18	25	75	87,5	14	TS_-U 4015-8-3
70		85	100	M8	9	18	25	75	87,5	17	TS_-U 4015-8-4
70		85	100	M8	9	18	25	75	87,5	19	TS_-U 4015-8-5
70		85	100	M8	9	18	25	75	87,5	22	TS_-U 4015-8-6
70		85	100	M8	9	18	25	75	87,5	11	TS_-U 4016-8-2
70		85	100	M8	9	18	25	75	87,5	14	TS_-U 4016-8-3
70		85	100	M8	9	18	25	75	87,5	17	TS_-U 4016-8-4
70		85	100	M8	9	18	25	75	87,5	20	TS_-U 4016-8-5
70		85	100	M8	9	18	25	75	87,5	23	TS_-U 4016-8-6
70		85	100	M8	9	18	25	75	87,5	11	TS_-U 4020-8-2
70		85	100	M8	9	18	25	75	87,5	15	TS_-U 4020-8-3
70		85	100	M8	9	18	25	75	87,5	18	TS_-U 4020-8-4
70		85	100	M8	9	18	25	75	87,5	21	TS_-U 4020-8-5
70		85	100	M8	9	18	25	75	87,5	12	TS_-U 4025-8-2
70		85	100	M8	9	18	25	75	87,5	16	TS_-U 4025-8-3
70		85	100	M8	9	18	25	75	87,5	20	TS_-U 4025-8-4
70		85	100	M8	9	18	25	75	87,5	13	TS_-U 4030-8-2
70		85	100	M8	9	18	25	75	87,5	17	TS_-U 4030-8-3
70		85	100	M8	9	18	25	75	87,5	14	TS_-U 4040-8-2
70		85	100	M8	9	18	25	75	87,5	15	TS_-U 4050-8-2
70		85	100	M8	9	18	25	75	87,5	17	TS_-U 4060-8-2
75		93	110	M10	11	16	10	85	97,5	6,3	TS_-S 5005-3-2
75		93	110	M10	11	16	10	85	97,5	7	TS_-S 5005-3-3
75		93	110	M10	11	16	10	85	97,5	7,6	TS_-S 5005-3-4

Key dimensions of the cylindrical nut: N, M, Y are obtained in the tables of page 38 of the catalogue.

SHUTON advises to use the dimensions of the tables, although it is possible to manufacture ball screw with other dimensions. In brackets () second options. Smaller nut diameters than the first option of the table can reduce the rigidity of the assembly between 5 and 10%.

Please consult SHUTON.

ATR, Single Nut

Ball screw reference	Nominal diameter	Lead	Ball diameter	Root diameter	Circuits	Dynamic load capacity	Static load capacity [kN]	Rigidity of ball contact zone	Rigidity of nut, with $F_{ext}:20\%C_a$	Nut length	
										d_0	P_h
TSB Flanged single nut TSL Cylindrical single nut Recirculation S and U	d_0	P_h	D_w	d_2	$i (le)$	$C_a (N)$	$C_{oa} (N)$	$R_{b/t} (N/\mu m)$	$R_{nut} (N/\mu m)$	TSB	TSL
TS_S 5005-3-5	50	5	3,175	47,8	5	26900	85800	1380	1120	62	52
TS_S 5005-3-6	50	5	3,175	47,8	6	31400	103000	1650	1330	67	57
TS_S 5006-4-2	50	6	3,969	47,2	2	18600	44800	630	510	49	39
TS_S 5006-4-3	50	6	3,969	47,2	3	25200	67100	910	740	56	46
TS_S 5006-4-4	50	6	3,969	47,2	4	31800	89500	1190	970	63	53
TS_S 5006-4-5	50	6	3,969	47,2	5	38300	111900	1470	1200	69	59
TS_S 5006-4-6	50	6	3,969	47,2	6	44700	134300	1750	1430	75	65
TS_S 5008-5-2	50	8	4,762	46,7	2	24100	53800	640	540	59	50
TS_S 5008-5-3	50	8	4,762	46,7	3	32600	80700	930	780	68	59
TS_S 5008-5-4	50	8	4,762	46,7	4	41200	107600	1210	1030	77	68
TS_S 5008-5-5	50	8	4,762	46,7	5	49600	134500	1500	1270	85	76
TS_S 5008-5-6	50	8	4,762	46,7	6	57900	161300	1780	1520	93	85
TS_S 5010-6-2	50	10	6,35	44,5	2	35500	70200	690	610	70	64
TS_S 5010-6-3	50	10	6,35	44,5	3	47900	105400	1000	880	81	76
TS_S 5010-6-4	50	10	6,35	44,5	4	60500	140500	1310	1160	92	86
TS_S 5010-6-5	50	10	6,35	44,5	5	73000	175600	1620	1440	103	97
TS_S 5010-6-6	50	10	6,35	44,5	6	85200	210700	1920	1710	113	107
TS_S 5010-6-7	50	10	6,35	44,5	7	97100	245800	2220	1980	123	117
TS_S 5010-6-8	50	10	6,35	44,5	8	108800	281000	2530	2250	134	128
TS_S 5012-8-2	50	12	7,938	44,5	2	44400	78700	610	530	78	74
TS_S 5012-8-3	50	12	7,938	44,5	3	60000	118000	880	770	92	88
TS_S 5012-8-4	50	12	7,938	44,5	4	75800	157300	1150	1010	105	101
TS_S 5012-8-5	50	12	7,938	44,5	5	91300	196700	1420	1250	117	113
TS_S 5012-8-6	50	12	7,938	44,5	6	106600	236000	1690	1490	130	126
TS_S 5012-8-7	50	12	7,938	44,5	7	121500	275300	1950	1730	142	138
TS_S 5012-8-8	50	12	7,938	44,5	8	136200	314700	2220	1970	154	150
TS_S 5015-8-2	50	15	7,938	44,5	2	44300	78600	600	540	87	83
TS_S 5015-8-3	50	15	7,938	44,5	3	59800	117800	870	790	104	100
TS_S 5015-8-4	50	15	7,938	44,5	4	75600	157100	1150	1040	120	116
TS_S 5015-8-5	50	15	7,938	44,5	5	91100	196400	1410	1280	136	132
TS_S 5015-8-6	50	15	7,938	44,5	6	106400	235700	1680	1520	152	148
TS_S 5015-8-7	50	15	7,938	44,5	7	121300	274900	1950	1770	167	163
TS_S 5016-8-2	50	16	7,938	44,5	2	44300	78500	600	550	86	82
TS_S 5016-8-3	50	16	7,938	44,5	3	59800	117800	870	790	104	100
TS_S 5016-8-4	50	16	7,938	44,5	4	75600	157000	1140	1040	122	118
TS_S 5016-8-5	50	16	7,938	44,5	5	91100	196300	1410	1290	138	134
TS_S 5016-8-6	50	16	7,938	44,5	6	106300	235500	1680	1530	155	151
TS_S 5016-8-7	50	16	7,938	44,5	7	121200	274800	1950	1770	171	167
TS_S 5020-8-2	50	20	7,938	44,5	2	44100	78300	600	550	98	92
TS_S 5020-8-3	50	20	7,938	44,5	3	59600	117500	870	800	122	116

* C_a and C_{oa} : Modified static and dynamic load capacities, calculated according to DIN 69051/4 standard and ISO3408/5. See pages 39 and 43.

** $R_{b/t}$: Rigidity of the balls contact zone for an external force 20% of C_a . See page 46. For different forces, multiply by $\sqrt[3]{F/0,2 C_a}$

*** R_{nu} : Total rigidity of the complete nut. It must be multiplied by the factor f_{ar} , which depends on the manufacturing tolerance. See page 48.

Nut dimensions										Grease quantity TS 'steel ball'	Ball screw reference
$D_{1, std}$	$D_{1, min}$	D_4	D_6	M	D_5	L_7	L_1	L_8	L_9	$Q_{gr, real, TS} (cm^3)$	TSB Flanged single nut TSL Cylindrical single nut Recirculation S and U
75		93	110	M10	11	16	10	85	97,5	8,2	TS_-S 5005-3-5
75		93	110	M10	11	16	10	85	97,5	8,7	TS_-S 5005-3-6
75		93	110	M10	11	16	10	85	97,5	8,5	TS_-S 5006-4-2
75		93	110	M10	11	16	10	85	97,5	9,6	TS_-S 5006-4-3
75		93	110	M10	11	16	10	85	97,5	11	TS_-S 5006-4-4
75		93	110	M10	11	16	10	85	97,5	12	TS_-S 5006-4-5
75		93	110	M10	11	16	10	85	97,5	12	TS_-S 5006-4-6
75		93	110	M10	11	16	10	85	97,5	11	TS_-S 5008-5-2
75		93	110	M10	11	16	10	85	97,5	13	TS_-S 5008-5-3
75		93	110	M10	11	16	10	85	97,5	15	TS_-S 5008-5-4
75		93	110	M10	11	16	10	85	97,5	16	TS_-S 5008-5-5
75		93	110	M10	11	16	10	85	97,5	17	TS_-S 5008-5-6
75		93	110	M10	11	16	16	85	97,5	15	TS_-S 5010-6-2
75		93	110	M10	11	16	16	85	97,5	18	TS_-S 5010-6-3
75		93	110	M10	11	16	16	85	97,5	20	TS_-S 5010-6-4
75		93	110	M10	11	16	16	85	97,5	22	TS_-S 5010-6-5
75		93	110	M10	11	16	16	85	97,5	24	TS_-S 5010-6-6
75		93	110	M10	11	16	16	85	97,5	26	TS_-S 5010-6-7
75		93	110	M10	11	16	16	85	97,5	29	TS_-S 5010-6-8
75		93	110	M10	11	16	20	85	97,5	25	TS_-S 5012-8-2
75		93	110	M10	11	16	20	85	97,5	30	TS_-S 5012-8-3
75		93	110	M10	11	16	20	85	97,5	34	TS_-S 5012-8-4
75		93	110	M10	11	16	20	85	97,5	38	TS_-S 5012-8-5
75		93	110	M10	11	16	20	85	97,5	42	TS_-S 5012-8-6
75		93	110	M10	11	16	20	85	97,5	46	TS_-S 5012-8-7
75		93	110	M10	11	16	20	85	97,5	50	TS_-S 5012-8-8
75		93	110	M10	11	16	20	85	97,5	26	TS_-S 5015-8-2
75		93	110	M10	11	16	20	85	97,5	32	TS_-S 5015-8-3
75		93	110	M10	11	16	20	85	97,5	37	TS_-S 5015-8-4
75		93	110	M10	11	16	20	85	97,5	42	TS_-S 5015-8-5
75		93	110	M10	11	16	20	85	97,5	48	TS_-S 5015-8-6
75		93	110	M10	11	16	20	85	97,5	52	TS_-S 5015-8-7
75		93	110	M10	11	16	20	85	97,5	25	TS_-S 5016-8-2
75		93	110	M10	11	16	20	85	97,5	31	TS_-S 5016-8-3
75		93	110	M10	11	16	20	85	97,5	37	TS_-S 5016-8-4
75		93	110	M10	11	16	20	85	97,5	42	TS_-S 5016-8-5
75		93	110	M10	11	16	20	85	97,5	47	TS_-S 5016-8-6
75		93	110	M10	11	16	20	85	97,5	53	TS_-S 5016-8-7
75		93	110	M10	11	18	20	85	97,5	28	TS_-S 5020-8-2
75		93	110	M10	11	18	20	85	97,5	36	TS_-S 5020-8-3

Key dimensions of the cylindrical nut: N, M, Y are obtained in the tables of page 38 of the catalogue.

SHUTON advises to use the dimensions of the tables, although it is possible to manufacture ball screw with other dimensions. In brackets () second options. Smaller nut diameters than the first option of the table can reduce the rigidity of the assembly between 5 and 10%.

Please consult SHUTON.

ATR, Single Nut

Ball screw reference	Nominal diameter	Lead	Ball diameter	Root diameter	Circuits	Dynamic load capacity	Static load capacity [kN]	Rigidity of ball contact zone	Rigidity of nut, with $F_{ext}:20\%C_a$	Nut length	
										<i>T</i> _{SB}	<i>T</i> _{SL}
TSB Flanged single nut TSL Cylindrical single nut Recirculation S and U	d_0	P_h	D_w	d_2	i ($1e$)	C_a (N)	C_{oa} (N)	$R_{b/t}$ (N/μm)	R_{nut} (N/μm)	<i>T</i> _{SB}	<i>T</i> _{SL}
TS-S 5020-8-4	50	20	7,938	44,5	4	75300	156600	1140	1060	143	137
TS-S 5020-8-5	50	20	7,938	44,5	5	90800	195800	1410	1300	164	158
TS-U 5010-6-2	50	10	6,35	44,5	2	35500	70200	680	600	56	56
TS-U 5010-6-3	50	10	6,35	44,5	3	49400	110200	1030	910	66	66
TS-U 5010-6-4	50	10	6,35	44,5	4	63700	151700	1370	1210	76	76
TS-U 5010-6-5	50	10	6,35	44,5	5	77300	191600	1700	1500	86	86
TS-U 5010-6-6	50	10	6,35	44,5	6	90700	231500	2010	1780	96	96
TS-U 5010-6-7	50	10	6,35	44,5	7	104100	273000	2330	2060	106	106
TS-U 5012-6-2	50	12	6,35	44,5	2	35400	70200	680	610	59	59
TS-U 5012-6-3	50	12	6,35	44,5	3	49300	110100	1030	930	71	71
TS-U 5012-6-4	50	12	6,35	44,5	4	63600	151500	1370	1230	83	83
TS-U 5012-6-5	50	12	6,35	44,5	5	77200	191400	1700	1530	95	95
TS-U 5012-6-6	50	12	6,35	44,5	6	90600	231300	2010	1810	107	107
TS-U 5012-6-7	50	12	6,35	44,5	7	104000	272800	2320	2100	119	119
TS-U 5015-6-2	50	15	6,35	44,5	2	35400	70100	680	620	64	64
TS-U 5015-6-3	50	15	6,35	44,5	3	49700	111500	1040	950	79	79
TS-U 5015-6-4	50	15	6,35	44,5	4	63500	151300	1370	1250	94	94
TS-U 5015-6-5	50	15	6,35	44,5	5	77100	191100	1690	1550	109	109
TS-U 5015-6-6	50	15	6,35	44,5	6	90800	232500	2020	1850	124	124
TS-U 5015-6-7	50	15	6,35	44,5	7	103800	272300	2320	2130	139	139
TS-U 5016-6-2	50	16	6,35	44,5	2	35300	70000	670	620	66	66
TS-U 5016-6-3	50	16	6,35	44,5	3	49600	111400	1040	960	82	82
TS-U 5016-6-4	50	16	6,35	44,5	4	63500	151200	1360	1260	98	98
TS-U 5016-6-5	50	16	6,35	44,5	5	77000	191000	1690	1560	114	114
TS-U 5016-6-6	50	16	6,35	44,5	6	90700	232400	2010	1860	130	130
TS-U 5016-6-7	50	16	6,35	44,5	7	103700	272200	2310	2140	146	146
TS-U 5020-6-2	50	20	6,35	44,5	2	35200	69800	670	630	73	73
TS-U 5020-6-3	50	20	6,35	44,5	3	49500	111100	1030	970	93	93
TS-U 5020-6-4	50	20	6,35	44,5	4	63200	150800	1360	1270	113	113
TS-U 5020-6-5	50	20	6,35	44,5	5	77200	192100	1690	1590	133	133
TS-U 5020-6-6	50	20	6,35	44,5	6	90400	231700	2000	1880	153	153
TS-U 5020-6-7	50	20	6,35	44,5	7	103700	273000	2310	2170	173	173
TS-U 5025-6-2	50	25	6,35	44,5	2	35600	71100	680	650	82	82
TS-U 5025-6-3	50	25	6,35	44,5	3	49200	110600	1020	970	107	107
TS-U 5025-6-4	50	25	6,35	44,5	4	63300	151700	1360	1290	132	132
TS-U 5025-6-5	50	25	6,35	44,5	5	76800	191200	1680	1590	157	157
TS-U 5025-6-6	50	25	6,35	44,5	6	90300	232300	2000	1900	182	182
TS-U 5030-6-2	50	30	6,35	44,5	2	35300	70700	670	640	91	91
TS-U 5030-6-3	50	30	6,35	44,5	3	49300	111600	1020	980	121	121
TS-U 5030-6-4	50	30	6,35	44,5	4	62900	150900	1340	1290	151	151

* C_a and C_{oa} : Modified static and dynamic load capacities, calculated according to DIN 69051/4 standard and ISO3408/5. See pages 39 and 43.

** $R_{b/t}$: Rigidity of the balls contact zone for an external force 20% of C_a . See page 46. For different forces, multiply by $\sqrt[3]{F/0,2 C_a}$

*** R_{nu} : Total rigidity of the complete nut. It must be multiplied by the factor f_{ar} , which depends on the manufacturing tolerance. See page 48.

Nut dimensions										Grease quantity TS 'steel ball'	Ball screw reference
$D_{1, std}$	$D_{1, min}$	D_4	D_6	M	D_5	L_7	L_1	L_8	L_9	$Q_{gr, real, TS} (cm^3)$	TSB Flanged single nut TSL Cylindrical single nut Recirculation S and U
75		93	110	M10	11	18	20	85	97,5	42	TS_-S 5020-8-4
75		93	110	M10	11	18	20	85	97,5	49	TS_-S 5020-8-5
75		93	110	M10	11	16	16	85	97,5	10	TS_-U 5010-6-2
75		93	110	M10	11	16	16	85	97,5	12	TS_-U 5010-6-3
75		93	110	M10	11	16	16	85	97,5	14	TS_-U 5010-6-4
75		93	110	M10	11	16	16	85	97,5	15	TS_-U 5010-6-5
75		93	110	M10	11	16	16	85	97,5	17	TS_-U 5010-6-6
75		93	110	M10	11	16	16	85	97,5	19	TS_-U 5010-6-7
75		93	110	M10	11	16	20	85	97,5	9,4	TS_-U 5012-6-2
75		93	110	M10	11	16	20	85	97,5	11	TS_-U 5012-6-3
75		93	110	M10	11	16	20	85	97,5	13	TS_-U 5012-6-4
75		93	110	M10	11	16	20	85	97,5	15	TS_-U 5012-6-5
75		93	110	M10	11	16	20	85	97,5	18	TS_-U 5012-6-6
75		93	110	M10	11	16	20	85	97,5	20	TS_-U 5012-6-7
75		93	110	M10	11	16	20	85	97,5	9,1	TS_-U 5015-6-2
75		93	110	M10	11	16	20	85	97,5	11	TS_-U 5015-6-3
75		93	110	M10	11	16	20	85	97,5	14	TS_-U 5015-6-4
75		93	110	M10	11	16	20	85	97,5	16	TS_-U 5015-6-5
75		93	110	M10	11	16	20	85	97,5	18	TS_-U 5015-6-6
75		93	110	M10	11	16	20	85	97,5	21	TS_-U 5015-6-7
75		93	110	M10	11	16	20	85	97,5	9,2	TS_-U 5016-6-2
75		93	110	M10	11	16	20	85	97,5	11	TS_-U 5016-6-3
75		93	110	M10	11	16	20	85	97,5	14	TS_-U 5016-6-4
75		93	110	M10	11	16	20	85	97,5	16	TS_-U 5016-6-5
75		93	110	M10	11	16	20	85	97,5	19	TS_-U 5016-6-6
75		93	110	M10	11	16	20	85	97,5	22	TS_-U 5016-6-7
75		93	110	M10	11	18	25	85	97,5	9,3	TS_-U 5020-6-2
75		93	110	M10	11	18	25	85	97,5	12	TS_-U 5020-6-3
75		93	110	M10	11	18	25	85	97,5	15	TS_-U 5020-6-4
75		93	110	M10	11	18	25	85	97,5	18	TS_-U 5020-6-5
75		93	110	M10	11	18	25	85	97,5	21	TS_-U 5020-6-6
75		93	110	M10	11	18	25	85	97,5	24	TS_-U 5020-6-7
75		93	110	M10	11	18	25	85	97,5	9,8	TS_-U 5025-6-2
75		93	110	M10	11	18	25	85	97,5	13	TS_-U 5025-6-3
75		93	110	M10	11	18	25	85	97,5	16	TS_-U 5025-6-4
75		93	110	M10	11	18	25	85	97,5	20	TS_-U 5025-6-5
75		93	110	M10	11	18	25	85	97,5	23	TS_-U 5025-6-6
75		93	110	M10	11	18	25	85	97,5	10	TS_-U 5030-6-2
75		93	110	M10	11	18	25	85	97,5	14	TS_-U 5030-6-3
75		93	110	M10	11	18	25	85	97,5	18	TS_-U 5030-6-4

Key dimensions of the cylindrical nut: N, M, Y are obtained in the tables of page 38 of the catalogue.

SHUTON advises to use the dimensions of the tables, although it is possible to manufacture ball screw with other dimensions. In brackets () second options. Smaller nut diameters than the first option of the table can reduce the rigidity of the assembly between 5 and 10%.

Please consult SHUTON.

ATR, Single Nut

Ball screw reference	Nominal diameter	Lead	Ball diameter	Root diameter	Circuits	Dynamic load capacity	Static load capacity [kN]	Rigidity of ball contact zone	Rigidity of nut, with $F_{ext}:20\%C_a$	Nut length	
										d_0	P_h
TSB Flanged single nut TSL Cylindrical single nut Recirculation S and U	d_0	P_h	D_w	d_2	$i (le)$	$C_a (N)$	$C_{oa} (N)$	$R_{b/t} (N/\mu m)$	$R_{nut} (N/\mu m)$	TSB	TSL
TS-U 5030-6-5	50	30	6,35	44,5	5	76700	191800	1670	1600	181	181
TS-U 5040-6-2	50	40	6,35	44,5	2	35200	71400	670	650	109	109
TS-U 5040-6-3	50	40	6,35	44,5	3	48900	111700	1010	980	149	149
TS-U 5040-6-4	50	40	6,35	44,5	4	62700	152100	1330	1290	189	189
TS-U 5050-6-2	50	50	6,35	44,5	2	34500	70200	640	630	129	128
TS-U 5050-6-3	50	50	6,35	44,5	3	48400	111500	990	960	178	178
TS-U 5060-6-2	50	60	6,35	44,5	2	34100	70400	630	620	145	145
TS-U 5080-6-2	50	80	6,35	44,5	2	33500	71600	610	600	181	181
TS-U 5012-8-2	50	12	7,938	43,3	2	48900	90400	760	700	65	65
TS-U 5012-8-3	50	12	7,938	43,3	3	69500	146200	1170	1070	77	77
TS-U 5012-8-4	50	12	7,938	43,3	4	89200	199400	1550	1430	89	89
TS-U 5012-8-5	50	12	7,938	43,3	5	109200	255200	1960	1800	101	101
TS-U 5012-8-6	50	12	7,938	43,3	6	128000	308400	2320	2130	113	113
TS-U 5012-8-7	50	12	7,938	43,3	7	147100	364300	2690	2470	125	125
TS-U 5012-8-8	50	12	7,938	43,3	8	165200	417400	3020	2780	137	137
TS-U 5015-8-2	50	15	7,938	43,3	2	48800	90300	760	710	70	70
TS-U 5015-8-3	50	15	7,938	43,3	3	69400	146000	1170	1090	85	85
TS-U 5015-8-4	50	15	7,938	43,3	4	89000	199100	1550	1450	100	100
TS-U 5015-8-5	50	15	7,938	43,3	5	108900	254900	1950	1820	115	115
TS-U 5015-8-6	50	15	7,938	43,3	6	127700	308000	2310	2160	130	130
TS-U 5015-8-7	50	15	7,938	43,3	7	146800	363700	2680	2500	145	145
TS-U 5015-8-8	50	15	7,938	43,3	8	164900	416800	3010	2810	160	160
TS-U 5016-8-2	50	16	7,938	43,3	2	48800	90200	760	710	72	72
TS-U 5016-8-3	50	16	7,938	43,3	3	69300	145900	1160	1090	88	88
TS-U 5016-8-4	50	16	7,938	43,3	4	88900	199000	1550	1450	104	104
TS-U 5016-8-5	50	16	7,938	43,3	5	108900	254700	1950	1830	120	120
TS-U 5016-8-6	50	16	7,938	43,3	6	127600	307800	2310	2170	136	136
TS-U 5016-8-7	50	16	7,938	43,3	7	146700	363500	2670	2510	152	152
TS-U 5016-8-8	50	16	7,938	43,3	8	164700	416600	3000	2820	168	168
TS-U 5020-8-2	50	20	7,938	43,3	2	49600	92600	780	740	79	79
TS-U 5020-8-3	50	20	7,938	43,3	3	69100	145500	1160	1100	99	99
TS-U 5020-8-4	50	20	7,938	43,3	4	89400	201100	1560	1480	119	119
TS-U 5020-8-5	50	20	7,938	43,3	5	108500	254000	1940	1840	139	139
TS-U 5020-8-6	50	20	7,938	43,3	6	127900	309600	2310	2200	159	159
TS-U 5020-8-7	50	20	7,938	43,3	7	146200	362500	2660	2530	179	179
TS-U 5025-8-2	50	25	7,938	43,3	2	49300	92200	770	740	87	87
TS-U 5025-8-3	50	25	7,938	43,3	3	68700	144900	1150	1100	112	112
TS-U 5025-8-4	50	25	7,938	43,3	4	88900	200300	1540	1480	137	137
TS-U 5025-8-5	50	25	7,938	43,3	5	108600	255600	1940	1860	162	162
TS-U 5025-8-6	50	25	7,938	43,3	6	127200	308300	2290	2200	187	187

* C_a and C_{oa} : Modified static and dynamic load capacities, calculated according to DIN 69051/4 standard and ISO3408/5. See pages 39 and 43.

** $R_{b/t}$: Rigidity of the balls contact zone for an external force 20% of C_a . See page 46. For different forces, multiply by $\sqrt[3]{F/0,2 C_a}$

*** R_{nu} : Total rigidity of the complete nut. It must be multiplied by the factor f_{ar} , which depends on the manufacturing tolerance. See page 48.

Nut dimensions										Grease quantity TS 'steel ball'	Ball screw reference
$D_{1, std}$	$D_{1, min}$	D_4	D_6	M	D_5	L_7	L_1	L_8	L_9	$Q_{gr, real, TS} (cm^3)$	TSB Flanged single nut TSL Cylindrical single nut Recirculation S and U
75		93	110	M10	11	18	25	85	97,5	22	TS_-U 5030-6-5
75		93	110	M10	11	18	25	85	97,5	12	TS_-U 5040-6-2
75		93	110	M10	11	18	25	85	97,5	17	TS_-U 5040-6-3
75		93	110	M10	11	18	25	85	97,5	22	TS_-U 5040-6-4
75		93	110	M10	11	18	25	85	97,5	14	TS_-U 5050-6-2
75		93	110	M10	11	18	25	85	97,5	19	TS_-U 5050-6-3
75		93	110	M10	11	18	25	85	97,5	15	TS_-U 5060-6-2
75		93	110	M10	11	18	25	85	97,5	19	TS_-U 5080-6-2
82		100	118	M10	11	16	25	92	105	15	TS_-U 5012-8-2
82		100	118	M10	11	16	25	92	105	18	TS_-U 5012-8-3
82		100	118	M10	11	16	25	92	105	21	TS_-U 5012-8-4
82		100	118	M10	11	16	25	92	105	23	TS_-U 5012-8-5
82		100	118	M10	11	16	25	92	105	26	TS_-U 5012-8-6
82		100	118	M10	11	16	25	92	105	29	TS_-U 5012-8-7
82		100	118	M10	11	16	25	92	105	33	TS_-U 5012-8-8
82		100	118	M10	11	16	25	92	105	14	TS_-U 5015-8-2
82		100	118	M10	11	16	25	92	105	18	TS_-U 5015-8-3
82		100	118	M10	11	16	25	92	105	21	TS_-U 5015-8-4
82		100	118	M10	11	16	25	92	105	24	TS_-U 5015-8-5
82		100	118	M10	11	16	25	92	105	28	TS_-U 5015-8-6
82		100	118	M10	11	16	25	92	105	31	TS_-U 5015-8-7
82		100	118	M10	11	16	25	92	105	35	TS_-U 5015-8-8
82		100	118	M10	11	16	25	92	105	14	TS_-U 5016-8-2
82		100	118	M10	11	16	25	92	105	18	TS_-U 5016-8-3
82		100	118	M10	11	16	25	92	105	21	TS_-U 5016-8-4
82		100	118	M10	11	16	25	92	105	25	TS_-U 5016-8-5
82		100	118	M10	11	16	25	92	105	28	TS_-U 5016-8-6
82		100	118	M10	11	16	25	92	105	32	TS_-U 5016-8-7
82		100	118	M10	11	16	25	92	105	36	TS_-U 5016-8-8
82		100	118	M10	11	18	25	92	105	14	TS_-U 5020-8-2
82		100	118	M10	11	18	25	92	105	19	TS_-U 5020-8-3
82		100	118	M10	11	18	25	92	105	23	TS_-U 5020-8-4
82		100	118	M10	11	18	25	92	105	27	TS_-U 5020-8-5
82		100	118	M10	11	18	25	92	105	31	TS_-U 5020-8-6
82		100	118	M10	11	18	25	92	105	36	TS_-U 5020-8-7
82		100	118	M10	11	18	25	92	105	15	TS_-U 5025-8-2
82		100	118	M10	11	18	25	92	105	20	TS_-U 5025-8-3
82		100	118	M10	11	18	25	92	105	25	TS_-U 5025-8-4
82		100	118	M10	11	18	25	92	105	30	TS_-U 5025-8-5
82		100	118	M10	11	18	25	92	105	35	TS_-U 5025-8-6

Key dimensions of the cylindrical nut: N, M, Y are obtained in the tables of page 38 of the catalogue.

SHUTON advises to use the dimensions of the tables, although it is possible to manufacture ball screw with other dimensions. In brackets () second options. Smaller nut diameters than the first option of the table can reduce the rigidity of the assembly between 5 and 10%.

Please consult SHUTON.

ATR, Single Nut

Ball screw reference	Nominal diameter	Lead	Ball diameter	Root diameter	Circuits	Dynamic load capacity	Static load capacity [kN]	Rigidity of ball contact zone	Rigidity of nut, with $F_{ext}:20\%C_a$	Nut length	
										d_0	P_h
TSB Flanged single nut TSL Cylindrical single nut Recirculation S and U	d_0	P_h	D_w	d_2	$i (le)$	$C_a (N)$	$C_{oa} (N)$	$R_{b/t} (N/\mu m)$	$R_{nut} (N/\mu m)$	TSB	TSL
TS-U 5030-8-2	50	30	7,938	43,3	2	49000	91800	760	730	96	96
TS-U 5030-8-3	50	30	7,938	43,3	3	69100	146800	1150	1120	126	126
TS-U 5030-8-4	50	30	7,938	43,3	4	88300	199200	1530	1480	156	156
TS-U 5030-8-5	50	30	7,938	43,3	5	107900	254300	1920	1850	186	186
TS-U 5040-8-2	50	40	7,938	43,3	2	49100	93200	760	740	115	115
TS-U 5040-8-3	50	40	7,938	43,3	3	68700	147500	1140	1110	156	155
TS-U 5040-8-4	50	40	7,938	43,3	4	88400	201900	1520	1490	195	195
TS-U 5050-8-2	50	50	7,938	43,3	2	48100	91700	730	720	133	133
TS-U 5050-8-3	50	50	7,938	43,3	3	68100	147700	1120	1100	183	183
TS-U 5060-8-2	50	60	7,938	43,3	2	47800	92500	720	710	145	145
TS-U 5080-8-2	50	80	7,938	43,3	2	46700	93200	690	680	180	180
TS-U 5016-9-2	50	16	9,525	42,2	2	62200	107700	770	730	83	83
TS-U 5016-9-3	50	16	9,525	42,2	3	87900	173000	1190	1120	99	99
TS-U 5016-9-4	50	16	9,525	42,2	4	113500	238400	1590	1500	115	115
TS-U 5016-9-5	50	16	9,525	42,2	5	139700	307600	2000	1890	131	131
TS-U 5016-9-6	50	16	9,525	42,2	6	164200	373000	2400	2260	147	147
TS-U 5016-9-7	50	16	9,525	42,2	7	188100	438400	2750	2590	163	163
TS-U 5016-9-8	50	16	9,525	42,2	8	211600	503700	3100	2930	179	179
TS-U 5020-9-2	50	20	9,525	42,2	2	61900	107400	760	730	85	85
TS-U 5020-9-3	50	20	9,525	42,2	3	87600	172600	1180	1130	105	105
TS-U 5020-9-4	50	20	9,525	42,2	4	114300	241600	1600	1530	125	125
TS-U 5020-9-5	50	20	9,525	42,2	5	139200	306800	1990	1900	145	145
TS-U 5020-9-6	50	20	9,525	42,2	6	163600	372000	2380	2270	165	165
TS-U 5020-9-7	50	20	9,525	42,2	7	187500	437200	2730	2610	185	185
TS-U 5025-9-2	50	25	9,525	42,2	2	61600	106900	760	730	93	93
TS-U 5025-9-3	50	25	9,525	42,2	3	88400	175700	1200	1150	118	118
TS-U 5025-9-4	50	25	9,525	42,2	4	113700	240600	1590	1530	143	143
TS-U 5025-9-5	50	25	9,525	42,2	5	138500	305500	1980	1900	168	168
TS-U 5025-9-6	50	25	9,525	42,2	6	163800	374300	2380	2300	193	193
TS-U 5030-9-2	50	30	9,525	42,2	2	61200	106400	750	730	101	101
TS-U 5030-9-3	50	30	9,525	42,2	3	87800	174800	1180	1150	131	131
TS-U 5030-9-4	50	30	9,525	42,2	4	113000	239400	1570	1520	161	161
TS-U 5030-9-5	50	30	9,525	42,2	5	138700	307800	1980	1920	191	191
TS-U 5040-9-2	50	40	9,525	42,2	2	61600	108800	750	740	118	118
TS-U 5040-9-3	50	40	9,525	42,2	3	86400	172600	1150	1130	158	158
TS-U 5040-9-4	50	40	9,525	42,2	4	112300	240200	1550	1520	188	188
TS-U 5050-9-2	50	50	9,525	42,2	2	60400	107100	730	720	135	135
TS-U 5050-9-3	50	50	9,525	42,2	3	85900	173600	1140	1120	185	185
TS-S 6305-3-2	63	5	3,175	60,8	2	14500	44100	720	540	48	36
TS-S 6305-3-3	63	5	3,175	60,8	3	19500	66100	1040	790	54	42

* C_a and C_{oa} : Modified static and dynamic load capacities, calculated according to DIN 69051/4 standard and ISO3408/5. See pages 39 and 43.

** $R_{b/t}$: Rigidity of the balls contact zone for an external force 20% of C_a . See page 46. For different forces, multiply by $\sqrt[3]{F/0,2 C_a}$

*** R_{nu} : Total rigidity of the complete nut. It must be multiplied by the factor f_{ar} , which depends on the manufacturing tolerance. See page 48.

Nut dimensions										Grease quantity TS 'steel ball'	Ball screw reference
$D_{1, std}$	$D_{1, min}$	D_4	D_6	M	D_5	L_7	L_1	L_8	L_9	$Q_{gr, real, TS} (cm^3)$	TSB Flanged single nut TSL Cylindrical single nut Recirculation S and U
82		100	118	M10	11	18	25	92	105	16	TS_-U 5030-8-2
82		100	118	M10	11	18	25	92	105	22	TS_-U 5030-8-3
82		100	118	M10	11	18	25	92	105	27	TS_-U 5030-8-4
82		100	118	M10	11	18	25	92	105	33	TS_-U 5030-8-5
82		100	118	M10	11	18	25	92	105	18	TS_-U 5040-8-2
82		100	118	M10	11	18	25	92	105	26	TS_-U 5040-8-3
82		100	118	M10	11	18	25	92	105	32	TS_-U 5040-8-4
82		100	118	M10	11	18	25	92	105	20	TS_-U 5050-8-2
82		100	118	M10	11	18	25	92	105	29	TS_-U 5050-8-3
82		100	118	M10	11	18	25	92	105	21	TS_-U 5060-8-2
82		100	118	M10	11	18	25	92	105	26	TS_-U 5080-8-2
90	(85)	108 (103)	125 (120)	M10	11	20	25	95 (90)	110 (105)	24	TS_-U 5016-9-2
90	(85)	108 (103)	125 (120)	M10	11	20	25	95 (90)	110 (105)	28	TS_-U 5016-9-3
90	(85)	108 (103)	125 (120)	M10	11	20	25	95 (90)	110 (105)	33	TS_-U 5016-9-4
90	(85)	108 (103)	125 (120)	M10	11	20	25	95 (90)	110 (105)	37	TS_-U 5016-9-5
90	(85)	108 (103)	125 (120)	M10	11	20	25	95 (90)	110 (105)	42	TS_-U 5016-9-6
90	(85)	108 (103)	125 (120)	M10	11	20	25	95 (90)	110 (105)	47	TS_-U 5016-9-7
90	(85)	108 (103)	125 (120)	M10	11	20	25	95 (90)	110 (105)	53	TS_-U 5016-9-8
90	(85)	108 (103)	125 (120)	M10	11	20	25	95 (90)	110 (105)	21	TS_-U 5020-9-2
90	(85)	108 (103)	125 (120)	M10	11	20	25	95 (90)	110 (105)	26	TS_-U 5020-9-3
90	(85)	108 (103)	125 (120)	M10	11	20	25	95 (90)	110 (105)	32	TS_-U 5020-9-4
90	(85)	108 (103)	125 (120)	M10	11	20	25	95 (90)	110 (105)	37	TS_-U 5020-9-5
90	(85)	108 (103)	125 (120)	M10	11	20	25	95 (90)	110 (105)	43	TS_-U 5020-9-6
90	(85)	108 (103)	125 (120)	M10	11	20	25	95 (90)	110 (105)	49	TS_-U 5020-9-7
90	(85)	108 (103)	125 (120)	M10	11	20	25	95 (90)	110 (105)	21	TS_-U 5025-9-2
90	(85)	108 (103)	125 (120)	M10	11	20	25	95 (90)	110 (105)	27	TS_-U 5025-9-3
90	(85)	108 (103)	125 (120)	M10	11	20	25	95 (90)	110 (105)	34	TS_-U 5025-9-4
90	(85)	108 (103)	125 (120)	M10	11	20	25	95 (90)	110 (105)	41	TS_-U 5025-9-5
90	(85)	108 (103)	125 (120)	M10	11	20	25	95 (90)	110 (105)	47	TS_-U 5025-9-6
90	(85)	108 (103)	125 (120)	M10	11	20	25	95 (90)	110 (105)	22	TS_-U 5030-9-2
90	(85)	108 (103)	125 (120)	M10	11	20	25	95 (90)	110 (105)	29	TS_-U 5030-9-3
90	(85)	108 (103)	125 (120)	M10	11	20	25	95 (90)	110 (105)	37	TS_-U 5030-9-4
90	(85)	108 (103)	125 (120)	M10	11	20	25	95 (90)	110 (105)	45	TS_-U 5030-9-5
90	(85)	108 (103)	125 (120)	M10	11	20	25	95 (90)	110 (105)	24	TS_-U 5040-9-2
90	(85)	108 (103)	125 (120)	M10	11	20	25	95 (90)	110 (105)	34	TS_-U 5040-9-3
90	(85)	108 (103)	125 (120)	M10	11	20	25	95 (90)	110 (105)	40	TS_-U 5040-9-4
90	(85)	108 (103)	125 (120)	M10	11	20	25	95 (90)	110 (105)	27	TS_-U 5050-9-2
90	(85)	108 (103)	125 (120)	M10	11	20	25	95 (90)	110 (105)	39	TS_-U 5050-9-3
90		108	125	M10	11	18	16	95	110	8,4	TS_-S 6305-3-2
90		108	125	M10	11	18	16	95	110	9,3	TS_-S 6305-3-3

Key dimensions of the cylindrical nut: N, M, Y are obtained in the tables of page 38 of the catalogue.

SHUTON advises to use the dimensions of the tables, although it is possible to manufacture ball screw with other dimensions. In brackets () second options. Smaller nut diameters than the first option of the table can reduce the rigidity of the assembly between 5 and 10%.

Please consult SHUTON.

ATR, Single Nut

Ball screw reference	Nominal diameter	Lead	Ball diameter	Root diameter	Circuits	Dynamic load capacity	Static load capacity [kN]	Rigidity of ball contact zone	Rigidity of nut, with $F_{ext}:20\%C_a$	Nut length	
										d_0	P_h
TSB Flanged single nut TSL Cylindrical single nut Recirculation S and U	d_0	P_h	D_w	d_2	$i (le)$	$C_a (N)$	$C_{oa} (N)$	$R_{b/t} (N/\mu m)$	$R_{nut} (N/\mu m)$	TSB	TSL
TS_S 6305-3-4	63	5	3,175	60,8	4	24700	88100	1370	1040	59	47
TS_S 6305-3-5	63	5	3,175	60,8	5	29700	110200	1690	1280	64	52
TS_S 6305-3-6	63	5	3,175	60,8	6	34700	132200	2010	1530	70	58
TS_S 6308-5-2	63	8	4,762	59,7	2	26500	68200	770	620	61	50
TS_S 6308-5-3	63	8	4,762	59,7	3	35800	102300	1120	910	70	60
TS_S 6308-5-4	63	8	4,762	59,7	4	45300	136400	1470	1190	79	68
TS_S 6308-5-5	63	8	4,762	59,7	5	54600	170500	1810	1470	87	77
TS_S 6308-5-6	63	8	4,762	59,7	6	63700	204600	2160	1760	95	85
TS_S 6310-6-2	63	10	6,35	57,5	2	39600	90400	850	720	72	64
TS_S 6310-6-3	63	10	6,35	57,5	3	53500	135600	1230	1050	84	76
TS_S 6310-6-4	63	10	6,35	57,5	4	67500	180700	1610	1370	95	86
TS_S 6310-6-5	63	10	6,35	57,5	5	81400	225900	1980	1700	105	97
TS_S 6310-6-6	63	10	6,35	57,5	6	95000	271100	2360	2030	115	107
TS_S 6310-6-7	63	10	6,35	57,5	7	108300	316300	2730	2350	123	117
TS_S 6310-6-8	63	10	6,35	57,5	8	121400	361500	3100	2670	136	128
TS_S 6312-8-2	63	12	7,938	57,5	2	52100	107900	790	680	82	74
TS_S 6312-8-3	63	12	7,938	57,5	3	70400	161900	1150	990	96	88
TS_S 6312-8-4	63	12	7,938	57,5	4	89000	215800	1500	1300	109	101
TS_S 6312-8-5	63	12	7,938	57,5	5	107200	269800	1850	1610	121	113
TS_S 6312-8-6	63	12	7,938	57,5	6	125100	323700	2210	1910	134	126
TS_S 6312-8-7	63	12	7,938	57,5	7	142700	377700	2550	2220	146	138
TS_S 6312-8-8	63	12	7,938	57,5	8	159900	431600	2900	2520	158	150
TS_S 6316-8-2	63	16	7,938	57,5	2	52000	107800	790	700	90	82
TS_S 6316-8-3	63	16	7,938	57,5	3	70300	161600	1140	1020	109	101
TS_S 6316-8-4	63	16	7,938	57,5	4	88800	215500	1500	1340	126	118
TS_S 6316-8-5	63	16	7,938	57,5	5	107000	269400	1850	1660	143	135
TS_S 6316-8-6	63	16	7,938	57,5	6	124900	323300	2200	1970	159	151
TS_S 6316-8-7	63	16	7,938	57,5	7	142400	377200	2550	2290	175	167
TS_S 6316-8-8	63	16	7,938	57,5	8	159600	431100	2890	2600	192	184
TS_S 6320-8-2	63	20	7,938	57,5	2	51900	107600	790	720	101	93
TS_S 6320-8-3	63	20	7,938	57,5	3	70100	161400	1140	1040	124	116
TS_S 6320-8-4	63	20	7,938	57,5	4	88600	215200	1490	1370	146	138
TS_S 6320-8-5	63	20	7,938	57,5	5	106800	269000	1840	1690	167	159
TS_S 6320-8-6	63	20	7,938	57,5	6	124600	322700	2190	2010	187	179
TS_S 6320-8-7	63	20	7,938	57,5	7	142100	376500	2540	2330	207	199
TS_U 6310-6-2	63	10	6,35	57,5	2	40100	92000	850	720	56	56
TS_U 6310-6-3	63	10	6,35	57,5	3	55600	143600	1260	1070	66	66
TS_U 6310-6-4	63	10	6,35	57,5	4	70700	193700	1660	1420	76	76
TS_U 6310-6-5	63	10	6,35	57,5	5	86000	245300	2070	1760	86	86
TS_U 6310-6-6	63	10	6,35	57,5	6	100900	296900	2460	2100	96	96

* C_a and C_{oa} : Modified static and dynamic load capacities, calculated according to DIN 69051/4 standard and ISO3408/5. See pages 39 and 43.

** $R_{b/t}$: Rigidity of the balls contact zone for an external force 20% of C_a . See page 46. For different forces, multiply by $\sqrt[3]{F/0,2 C_a}$

*** R_{nu} : Total rigidity of the complete nut. It must be multiplied by the factor f_{ar} , which depends on the manufacturing tolerance. See page 48.

Nut dimensions										Grease quantity TS 'steel ball'	Ball screw reference
$D_{1, std}$	$D_{1, min}$	D_4	D_6	M	D_5	L_7	L_1	L_8	L_9	$Q_{gr, real, TS} (cm^3)$	TSB Flanged single nut TSL Cylindrical single nut Recirculation S and U
90		108	125	M10	11	18	16	95	110	10	TS_-S 6305-3-4
90		108	125	M10	11	18	16	95	110	11	TS_-S 6305-3-5
90		108	125	M10	11	18	16	95	110	12	TS_-S 6305-3-6
90		108	125	M10	11	18	16	95	110	15	TS_-S 6308-5-2
90		108	125	M10	11	18	16	95	110	17	TS_-S 6308-5-3
90		108	125	M10	11	18	16	95	110	19	TS_-S 6308-5-4
90		108	125	M10	11	18	16	95	110	21	TS_-S 6308-5-5
90		108	125	M10	11	18	16	95	110	22	TS_-S 6308-5-6
90		108	125	M10	11	18	16	95	110	20	TS_-S 6310-6-2
90		108	125	M10	11	18	16	95	110	23	TS_-S 6310-6-3
90		108	125	M10	11	18	16	95	110	26	TS_-S 6310-6-4
90		108	125	M10	11	18	16	95	110	29	TS_-S 6310-6-5
90		108	125	M10	11	18	16	95	110	31	TS_-S 6310-6-6
90		108	125	M10	11	18	16	95	110	32	TS_-S 6310-6-7
90		108	125	M10	11	18	16	95	110	36	TS_-S 6310-6-8
95	(90)	115 (108)	135 (125)	M12 (M10)	13,5 (11)	20	25	100 (95)	117,5 (110)	33	TS_-S 6312-8-2
95	(90)	115 (108)	135 (125)	M12 (M10)	13,5 (11)	20	25	100 (95)	117,5 (110)	39	TS_-S 6312-8-3
95	(90)	115 (108)	135 (125)	M12 (M10)	13,5 (11)	20	25	100 (95)	117,5 (110)	44	TS_-S 6312-8-4
95	(90)	115 (108)	135 (125)	M12 (M10)	13,5 (11)	20	25	100 (95)	117,5 (110)	48	TS_-S 6312-8-5
95	(90)	115 (108)	135 (125)	M12 (M10)	13,5 (11)	20	25	100 (95)	117,5 (110)	53	TS_-S 6312-8-6
95	(90)	115 (108)	135 (125)	M12 (M10)	13,5 (11)	20	25	100 (95)	117,5 (110)	58	TS_-S 6312-8-7
95	(90)	115 (108)	135 (125)	M12 (M10)	13,5 (11)	20	25	100 (95)	117,5 (110)	62	TS_-S 6312-8-8
95	(90)	115 (108)	135 (125)	M12 (M10)	13,5 (11)	20	25	100 (95)	117,5 (110)	33	TS_-S 6316-8-2
95	(90)	115 (108)	135 (125)	M12 (M10)	13,5 (11)	20	25	100 (95)	117,5 (110)	40	TS_-S 6316-8-3
95	(90)	115 (108)	135 (125)	M12 (M10)	13,5 (11)	20	25	100 (95)	117,5 (110)	47	TS_-S 6316-8-4
95	(90)	115 (108)	135 (125)	M12 (M10)	13,5 (11)	20	25	100 (95)	117,5 (110)	54	TS_-S 6316-8-5
95	(90)	115 (108)	135 (125)	M12 (M10)	13,5 (11)	20	25	100 (95)	117,5 (110)	59	TS_-S 6316-8-6
95	(90)	115 (108)	135 (125)	M12 (M10)	13,5 (11)	20	25	100 (95)	117,5 (110)	65	TS_-S 6316-8-7
95	(90)	115 (108)	135 (125)	M12 (M10)	13,5 (11)	20	25	100 (95)	117,5 (110)	72	TS_-S 6316-8-8
95	(90)	115 (108)	135 (125)	M12 (M10)	13,5 (11)	20	25	100 (95)	117,5 (115)	35	TS_-S 6320-8-2
95	(90)	115 (108)	135 (125)	M12 (M10)	13,5 (11)	20	25	100 (95)	117,5 (115)	45	TS_-S 6320-8-3
95	(90)	115 (108)	135 (125)	M12 (M10)	13,5 (11)	20	25	100 (95)	117,5 (115)	53	TS_-S 6320-8-4
95	(90)	115 (108)	135 (125)	M12 (M10)	13,5 (11)	20	25	100 (95)	117,5 (115)	61	TS_-S 6320-8-5
95	(90)	115 (108)	135 (125)	M12 (M10)	13,5 (11)	20	25	100 (95)	117,5 (115)	68	TS_-S 6320-8-6
95	(90)	115 (108)	135 (125)	M12 (M10)	13,5 (11)	20	25	100 (95)	117,5 (115)	76	TS_-S 6320-8-7
90		108	125	M10	11	18	16	95	110	12	TS_-U 6310-6-2
90		108	125	M10	11	18	16	95	110	15	TS_-U 6310-6-3
90		108	125	M10	11	18	16	95	110	17	TS_-U 6310-6-4
90		108	125	M10	11	18	16	95	110	19	TS_-U 6310-6-5
90		108	125	M10	11	18	16	95	110	21	TS_-U 6310-6-6

Key dimensions of the cylindrical nut: N, M, Y are obtained in the tables of page 38 of the catalogue.

SHUTON advises to use the dimensions of the tables, although it is possible to manufacture ball screw with other dimensions. In brackets () second options. Smaller nut diameters than the first option of the table can reduce the rigidity of the assembly between 5 and 10%.

Please consult SHUTON.

ATR, Single Nut

Ball screw reference	Nominal diameter	Lead	Ball diameter	Root diameter	Circuits	Dynamic load capacity	Static load capacity [kN]	Rigidity of ball contact zone	Rigidity of nut, with $F_{ext}=20\%C_a$	Nut length	
										<i>TSB</i>	<i>TSL</i>
TSB Flanged single nut TSL Cylindrical single nut Recirculation S and U	d_0	P_h	D_w	d_2	$i (1e)$	$C_a (N)$	$C_{oa} (N)$	$R_{b/t} (N/\mu m)$	$R_{nut} (N/\mu m)$	<i>TSB</i>	<i>TSL</i>
TS-U 6312-8-2	63	12	7,938	56,3	2	56400	121200	960	850	65	65
TS-U 6312-8-3	63	12	7,938	56,3	3	78000	188500	1450	1290	77	77
TS-U 6312-8-4	63	12	7,938	56,3	4	100500	258600	1920	1710	89	89
TS-U 6312-8-5	63	12	7,938	56,3	5	121800	325900	2370	2110	101	101
TS-U 6312-8-6	63	12	7,938	56,3	6	143300	395900	2820	2520	113	113
TS-U 6312-8-7	63	12	7,938	56,3	7	164300	466000	3260	2910	125	125
TS-U 6315-8-2	63	15	7,938	56,3	2	56300	121100	960	870	71	71
TS-U 6315-8-3	63	15	7,938	56,3	3	77900	188400	1440	1310	86	86
TS-U 6315-8-4	63	15	7,938	56,3	4	100300	258300	1920	1740	101	101
TS-U 6315-8-5	63	15	7,938	56,3	5	122300	328300	2390	2170	116	116
TS-U 6315-8-6	63	15	7,938	56,3	6	143100	395500	2820	2570	131	131
TS-U 6315-8-7	63	15	7,938	56,3	7	164100	465500	3250	2970	146	146
TS-U 6316-8-2	63	16	7,938	56,3	2	56300	121000	960	880	74	73
TS-U 6316-8-3	63	16	7,938	56,3	3	77900	188300	1440	1320	89	89
TS-U 6316-8-4	63	16	7,938	56,3	4	100300	258200	1910	1750	105	105
TS-U 6316-8-5	63	16	7,938	56,3	5	122200	328200	2380	2180	121	121
TS-U 6316-8-6	63	16	7,938	56,3	6	143000	395400	2820	2580	137	137
TS-U 6316-8-7	63	16	7,938	56,3	7	164000	465300	3250	2980	153	153
TS-U 6320-8-2	63	20	7,938	56,3	2	56200	120800	950	890	80	80
TS-U 6320-8-3	63	20	7,938	56,3	3	77700	188000	1440	1340	100	100
TS-U 6320-8-4	63	20	7,938	56,3	4	100100	257800	1910	1780	122	120
TS-U 6320-8-5	63	20	7,938	56,3	5	121900	327600	2370	2210	142	140
TS-U 6320-8-6	63	20	7,938	56,3	6	142700	394700	2810	2620	160	160
TS-U 6320-8-7	63	20	7,938	56,3	7	163600	464500	3240	3020	180	180
TS-U 6325-8-2	63	25	7,938	56,3	2	56000	120500	950	900	89	89
TS-U 6325-8-3	63	25	7,938	56,3	3	78200	190100	1450	1370	114	114
TS-U 6325-8-4	63	25	7,938	56,3	4	99700	257100	1900	1790	139	139
TS-U 6325-8-5	63	25	7,938	56,3	5	121500	326700	2360	2230	164	164
TS-U 6325-8-6	63	25	7,938	56,3	6	142800	396300	2810	2650	189	189
TS-U 6325-8-7	63	25	7,938	56,3	7	163700	465900	3240	3060	214	214
TS-U 6330-8-2	63	30	7,938	56,3	2	55700	120100	940	900	97	97
TS-U 6330-8-3	63	30	7,938	56,3	3	77800	189500	1440	1370	127	127
TS-U 6330-8-4	63	30	7,938	56,3	4	100000	258900	1900	1810	157	157
TS-U 6330-8-5	63	30	7,938	56,3	5	121700	328300	2360	2250	187	187
TS-U 6330-8-6	63	30	7,938	56,3	6	142200	395000	2790	2660	217	217
TS-U 6330-8-7	63	30	7,938	56,3	7	163000	464400	3220	3070	247	247
TS-U 6340-8-2	63	40	7,938	56,3	2	56000	121800	950	910	115	115
TS-U 6340-8-3	63	40	7,938	56,3	3	77700	190600	1430	1380	155	155
TS-U 6340-8-4	63	40	7,938	56,3	4	99600	259400	1890	1820	195	195
TS-U 6340-8-5	63	40	7,938	56,3	5	121000	328200	2340	2260	235	235

* C_a and C_{oa} : Modified static and dynamic load capacities, calculated according to DIN 69051/4 standard and ISO3408/5. See pages 39 and 43.

** $R_{b/t}$: Rigidity of the balls contact zone for an external force 20% of C_a . See page 46. For different forces, multiply by $\sqrt[3]{F/0,2 C_a}$

*** R_{nu} : Total rigidity of the complete nut. It must be multiplied by the factor f_{ar} , which depends on the manufacturing tolerance. See page 48.

Nut dimensions										Grease quantity TS 'steel ball'	Ball screw reference
$D_{1, std}$	$D_{1, min}$	D_4	D_6	M	D_5	L_7	L_1	L_8	L_9	$Q_{gr, real, TS} (cm^3)$	TSB Flanged single nut TSL Cylindrical single nut Recirculation S and U
95		115	135	M12	13,5	20	25	100	117,5	18	TS_-U 6312-8-2
95		115	135	M12	13,5	20	25	100	117,5	22	TS_-U 6312-8-3
95		115	135	M12	13,5	20	25	100	117,5	25	TS_-U 6312-8-4
95		115	135	M12	13,5	20	25	100	117,5	29	TS_-U 6312-8-5
95		115	135	M12	13,5	20	25	100	117,5	33	TS_-U 6312-8-6
95		115	135	M12	13,5	20	25	100	117,5	37	TS_-U 6312-8-7
95		115	135	M12	13,5	20	25	100	117,5	18	TS_-U 6315-8-2
95		115	135	M12	13,5	20	25	100	117,5	22	TS_-U 6315-8-3
95		115	135	M12	13,5	20	25	100	117,5	26	TS_-U 6315-8-4
95		115	135	M12	13,5	20	25	100	117,5	31	TS_-U 6315-8-5
95		115	135	M12	13,5	20	25	100	117,5	35	TS_-U 6315-8-6
95		115	135	M12	13,5	20	25	100	117,5	40	TS_-U 6315-8-7
95		115	135	M12	13,5	20	25	100	117,5	19	TS_-U 6316-8-2
95		115	135	M12	13,5	20	25	100	117,5	22	TS_-U 6316-8-3
95		115	135	M12	13,5	20	25	100	117,5	27	TS_-U 6316-8-4
95		115	135	M12	13,5	20	25	100	117,5	31	TS_-U 6316-8-5
95		115	135	M12	13,5	20	25	100	117,5	36	TS_-U 6316-8-6
95		115	135	M12	13,5	20	25	100	117,5	41	TS_-U 6316-8-7
95		115	135	M12	13,5	20	25	100	117,5	18	TS_-U 6320-8-2
95		115	135	M12	13,5	20	25	100	117,5	23	TS_-U 6320-8-3
95		115	135	M12	13,5	20	25	100	117,5	29	TS_-U 6320-8-4
95		115	135	M12	13,5	20	25	100	117,5	35	TS_-U 6320-8-5
95		115	135	M12	13,5	20	25	100	117,5	39	TS_-U 6320-8-6
95		115	135	M12	13,5	20	25	100	117,5	45	TS_-U 6320-8-7
95		115	135	M12	13,5	20	25	100	117,5	19	TS_-U 6325-8-2
95		115	135	M12	13,5	20	25	100	117,5	25	TS_-U 6325-8-3
95		115	135	M12	13,5	20	25	100	117,5	31	TS_-U 6325-8-4
95		115	135	M12	13,5	20	25	100	117,5	38	TS_-U 6325-8-5
95		115	135	M12	13,5	20	25	100	117,5	44	TS_-U 6325-8-6
95		115	135	M12	13,5	20	25	100	117,5	51	TS_-U 6325-8-7
95		115	135	M12	13,5	20	25	100	117,5	20	TS_-U 6330-8-2
95		115	135	M12	13,5	20	25	100	117,5	27	TS_-U 6330-8-3
95		115	135	M12	13,5	20	25	100	117,5	34	TS_-U 6330-8-4
95		115	135	M12	13,5	20	25	100	117,5	41	TS_-U 6330-8-5
95		115	135	M12	13,5	20	25	100	117,5	49	TS_-U 6330-8-6
95		115	135	M12	13,5	20	25	100	117,5	57	TS_-U 6330-8-7
95		115	135	M12	13,5	20	25	100	117,5	23	TS_-U 6340-8-2
95		115	135	M12	13,5	20	25	100	117,5	32	TS_-U 6340-8-3
95		115	135	M12	13,5	20	25	100	117,5	41	TS_-U 6340-8-4
95		115	135	M12	13,5	20	25	100	117,5	50	TS_-U 6340-8-5

Key dimensions of the cylindrical nut: N, M, Y are obtained in the tables of page 38 of the catalogue.

SHUTON advises to use the dimensions of the tables, although it is possible to manufacture ball screw with other dimensions. In brackets () second options. Smaller nut diameters than the first option of the table can reduce the rigidity of the assembly between 5 and 10%.

Please consult SHUTON.

ATR, Single Nut

Ball screw reference	Nominal diameter	Lead	Ball diameter	Root diameter	Circuits	Dynamic load capacity	Static load capacity [kN]	Rigidity of ball contact zone	Rigidity of nut, with $F_{ext}:20\%C_a$	Nut length	
										d_0	P_h
TSB Flanged single nut TSL Cylindrical single nut Recirculation S and U	d_0	P_h	D_w	d_2	$i (le)$	$C_a (N)$	$C_{oa} (N)$	$R_{b/t} (N/\mu m)$	$R_{nut} (N/\mu m)$	TSB	TSL
TS-U 6340-8-6	63	40	7,938	56,3	6	142000	397100	2780	2680	275	275
TS-U 6350-8-2	63	50	7,938	56,3	2	55200	120500	920	900	135	135
TS-U 6350-8-3	63	50	7,938	56,3	3	76700	188600	1400	1360	185	185
TS-U 6350-8-4	63	50	7,938	56,3	4	98900	259300	1860	1810	235	235
TS-U 6316-9-2	63	16	9,525	55,2	2	72200	144600	990	910	80	80
TS-U 6316-9-3	63	16	9,525	55,2	3	100400	226600	1470	1360	96	96
TS-U 6316-9-4	63	16	9,525	55,2	4	129800	312600	1980	1830	112	112
TS-U 6316-9-5	63	16	9,525	55,2	5	157400	394700	2460	2270	128	128
TS-U 6316-9-6	63	16	9,525	55,2	6	185500	480600	2920	2710	144	144
TS-U 6316-9-7	63	16	9,525	55,2	7	212100	562700	3360	3110	160	160
TS-U 6316-9-8	63	16	9,525	55,2	8	239000	648600	3800	3520	176	176
TS-U 6320-9-2	63	20	9,525	55,2	2	72000	144300	980	920	87	87
TS-U 6320-9-3	63	20	9,525	55,2	3	100200	226200	1470	1380	107	107
TS-U 6320-9-4	63	20	9,525	55,2	4	129500	312100	1970	1850	127	127
TS-U 6320-9-5	63	20	9,525	55,2	5	157100	394000	2450	2300	147	147
TS-U 6320-9-6	63	20	9,525	55,2	6	185100	479800	2910	2740	167	167
TS-U 6320-9-7	63	20	9,525	55,2	7	211600	561700	3350	3150	187	187
TS-U 6320-9-8	63	20	9,525	55,2	8	238500	647500	3790	3560	207	207
TS-U 6325-9-2	63	25	9,525	55,2	2	71800	143900	980	930	95	95
TS-U 6325-9-3	63	25	9,525	55,2	3	99800	225600	1460	1390	120	120
TS-U 6325-9-4	63	25	9,525	55,2	4	129000	311200	1960	1870	145	145
TS-U 6325-9-5	63	25	9,525	55,2	5	157600	396800	2460	2340	170	170
TS-U 6325-9-6	63	25	9,525	55,2	6	184500	478500	2900	2760	195	195
TS-U 6325-9-7	63	25	9,525	55,2	7	211800	564100	3350	3190	220	220
TS-U 6325-9-8	63	25	9,525	55,2	8	237700	645800	3760	3590	245	245
TS-U 6330-9-2	63	30	9,525	55,2	2	71500	143500	970	930	104	104
TS-U 6330-9-3	63	30	9,525	55,2	3	100600	228800	1470	1410	134	134
TS-U 6330-9-4	63	30	9,525	55,2	4	128500	310200	1950	1870	164	164
TS-U 6330-9-5	63	30	9,525	55,2	5	156900	395500	2440	2340	194	194
TS-U 6330-9-6	63	30	9,525	55,2	6	184700	480800	2900	2780	224	224
TS-U 6330-9-7	63	30	9,525	55,2	7	210900	562300	3330	3200	254	254
TS-U 6330-9-8	63	30	9,525	55,2	8	237600	647600	3760	3610	274	274
TS-U 6340-9-2	63	40	9,525	55,2	2	70700	142300	960	930	120	120
TS-U 6340-9-3	63	40	9,525	55,2	3	99500	226900	1450	1400	160	160
TS-U 6340-9-4	63	40	9,525	55,2	4	128200	311600	1940	1880	200	200
TS-U 6340-9-5	63	40	9,525	55,2	5	156300	396200	2420	2350	240	240
TS-U 6340-9-6	63	40	9,525	55,2	6	183700	480800	2870	2780	270	270
TS-U 6350-9-2	63	50	9,525	55,2	2	71000	144700	960	940	137	137
TS-U 6350-9-3	63	50	9,525	55,2	3	99300	228400	1440	1400	187	187
TS-U 6350-9-4	63	50	9,525	55,2	4	127500	312200	1920	1870	237	237

* C_a and C_{oa} : Modified static and dynamic load capacities, calculated according to DIN 69051/4 standard and ISO3408/5. See pages 39 and 43.

** $R_{b/t}$: Rigidity of the balls contact zone for an external force 20% of C_a . See page 46. For different forces, multiply by $\sqrt[3]{F/0,2 C_a}$

*** R_{nu} : Total rigidity of the complete nut. It must be multiplied by the factor f_{ar} , which depends on the manufacturing tolerance. See page 48.

Nut dimensions										Grease quantity TS 'steel ball'	Ball screw reference
$D_{1, std}$	$D_{1, min}$	D_4	D_6	M	D_5	L_7	L_1	L_8	L_9	$Q_{gr, real, TS} (cm^3)$	TSB Flanged single nut TSL Cylindrical single nut Recirculation S and U
95		115	135	M12	13,5	20	25	100	117,5	60	TS_-U 6340-8-6
95		115	135	M12	13,5	20	25	100	117,5	27	TS_-U 6350-8-2
95		115	135	M12	13,5	20	25	100	117,5	38	TS_-U 6350-8-3
95		115	135	M12	13,5	20	25	100	117,5	49	TS_-U 6350-8-4
105	(100)	125 (120)	145 (140)	M12	13,5	20	25	110 (105)	127,5 (122,5)	27	TS_-U 6316-9-2
105	(100)	125 (120)	145 (140)	M12	13,5	20	25	110 (105)	127,5 (122,5)	33	TS_-U 6316-9-3
105	(100)	125 (120)	145 (140)	M12	13,5	20	25	110 (105)	127,5 (122,5)	38	TS_-U 6316-9-4
105	(100)	125 (120)	145 (140)	M12	13,5	20	25	110 (105)	127,5 (122,5)	44	TS_-U 6316-9-5
105	(100)	125 (120)	145 (140)	M12	13,5	20	25	110 (105)	127,5 (122,5)	50	TS_-U 6316-9-6
105	(100)	125 (120)	145 (140)	M12	13,5	20	25	110 (105)	127,5 (122,5)	57	TS_-U 6316-9-7
105	(100)	125 (120)	145 (140)	M12	13,5	20	25	110 (105)	127,5 (122,5)	63	TS_-U 6316-9-8
105	(100)	125 (120)	145 (140)	M12	13,5	20	25	110 (105)	127,5 (122,5)	27	TS_-U 6320-9-2
105	(100)	125 (120)	145 (140)	M12	13,5	20	25	110 (105)	127,5 (122,5)	34	TS_-U 6320-9-3
105	(100)	125 (120)	145 (140)	M12	13,5	20	25	110 (105)	127,5 (122,5)	40	TS_-U 6320-9-4
105	(100)	125 (120)	145 (140)	M12	13,5	20	25	110 (105)	127,5 (122,5)	47	TS_-U 6320-9-5
105	(100)	125 (120)	145 (140)	M12	13,5	20	25	110 (105)	127,5 (122,5)	54	TS_-U 6320-9-6
105	(100)	125 (120)	145 (140)	M12	13,5	20	25	110 (105)	127,5 (122,5)	62	TS_-U 6320-9-7
105	(100)	125 (120)	145 (140)	M12	13,5	20	25	110 (105)	127,5 (122,5)	69	TS_-U 6320-9-8
105	(100)	125 (120)	145 (140)	M12	13,5	20	25	110 (105)	127,5 (122,5)	27	TS_-U 6325-9-2
105	(100)	125 (120)	145 (140)	M12	13,5	20	25	110 (105)	127,5 (122,5)	35	TS_-U 6325-9-3
105	(100)	125 (120)	145 (140)	M12	13,5	20	25	110 (105)	127,5 (122,5)	43	TS_-U 6325-9-4
105	(100)	125 (120)	145 (140)	M12	13,5	20	25	110 (105)	127,5 (122,5)	51	TS_-U 6325-9-5
105	(100)	125 (120)	145 (140)	M12	13,5	20	25	110 (105)	127,5 (122,5)	60	TS_-U 6325-9-6
105	(100)	125 (120)	145 (140)	M12	13,5	20	25	110 (105)	127,5 (122,5)	69	TS_-U 6325-9-7
105	(100)	125 (120)	145 (140)	M12	13,5	20	25	110 (105)	127,5 (122,5)	78	TS_-U 6325-9-8
105	(100)	125 (120)	145 (140)	M12	13,5	20	25	110 (105)	127,5 (122,5)	28	TS_-U 6330-9-2
105	(100)	125 (120)	145 (140)	M12	13,5	20	25	110 (105)	127,5 (122,5)	38	TS_-U 6330-9-3
105	(100)	125 (120)	145 (140)	M12	13,5	20	25	110 (105)	127,5 (122,5)	47	TS_-U 6330-9-4
105	(100)	125 (120)	145 (140)	M12	13,5	20	25	110 (105)	127,5 (122,5)	57	TS_-U 6330-9-5
105	(100)	125 (120)	145 (140)	M12	13,5	20	25	110 (105)	127,5 (122,5)	67	TS_-U 6330-9-6
105	(100)	125 (120)	145 (140)	M12	13,5	20	25	110 (105)	127,5 (122,5)	77	TS_-U 6330-9-7
105	(100)	125 (120)	145 (140)	M12	13,5	20	25	110 (105)	127,5 (122,5)	82	TS_-U 6330-9-8
105	(100)	125 (120)	145 (140)	M12	13,5	20	25	110 (105)	127,5 (122,5)	31	TS_-U 6340-9-2
105	(100)	125 (120)	145 (140)	M12	13,5	20	25	110 (105)	127,5 (122,5)	43	TS_-U 6340-9-3
105	(100)	125 (120)	145 (140)	M12	13,5	20	25	110 (105)	127,5 (122,5)	56	TS_-U 6340-9-4
105	(100)	125 (120)	145 (140)	M12	13,5	20	25	110 (105)	127,5 (122,5)	68	TS_-U 6340-9-5
105	(100)	125 (120)	145 (140)	M12	13,5	20	25	110 (105)	127,5 (122,5)	76	TS_-U 6340-9-6
105	(100)	125 (120)	145 (140)	M12	13,5	20	25	110 (105)	127,5 (122,5)	35	TS_-U 6350-9-2
105	(100)	125 (120)	145 (140)	M12	13,5	20	25	110 (105)	127,5 (122,5)	50	TS_-U 6350-9-3
105	(100)	125 (120)	145 (140)	M12	13,5	20	25	110 (105)	127,5 (122,5)	65	TS_-U 6350-9-4

Key dimensions of the cylindrical nut: N, M, Y are obtained in the tables of page 38 of the catalogue.

SHUTON advises to use the dimensions of the tables, although it is possible to manufacture ball screw with other dimensions. In brackets () second options. Smaller nut diameters than the first option of the table can reduce the rigidity of the assembly between 5 and 10%.

Please consult SHUTON.

ATR, Single Nut

Ball screw reference	Nominal diameter	Lead	Ball diameter	Root diameter	Circuits	Dynamic load capacity	Static load capacity [kN]	Rigidity of ball contact zone	Rigidity of nut, with $F_{ext}:20\%C_a$	Nut length	
										d_0	P_h
TSB Flanged single nut TSL Cylindrical single nut Recirculation S and U	d_0	P_h	D_w	d_2	$i (le)$	$C_a (N)$	$C_{oa} (N)$	$R_{b/t} (N/\mu m)$	$R_{nut} (N/\mu m)$	TSB	TSL
TS-U 6320-11-2	63	20	11,113	54,1	2	87500	165700	1000	940	86	86
TS-U 6320-11-3	63	20	11,113	54,1	3	122400	261900	1530	1430	106	106
TS-U 6320-11-4	63	20	11,113	54,1	4	158800	363500	2050	1930	126	126
TS-U 6320-11-5	63	20	11,113	54,1	5	194400	465000	2580	2420	146	146
TS-U 6320-11-6	63	20	11,113	54,1	6	227700	561300	3050	2860	166	166
TS-U 6320-11-7	63	20	11,113	54,1	7	261800	662800	3520	3310	186	186
TS-U 6320-11-8	63	20	11,113	54,1	8	293800	759000	3960	3730	206	206
TS-U 6325-11-2	63	25	11,113	54,1	2	87200	165300	1000	950	94	94
TS-U 6325-11-3	63	25	11,113	54,1	3	122000	261200	1520	1440	119	119
TS-U 6325-11-4	63	25	11,113	54,1	4	158300	362500	2040	1940	144	144
TS-U 6325-11-5	63	25	11,113	54,1	5	193800	463800	2560	2440	169	169
TS-U 6325-11-6	63	25	11,113	54,1	6	227000	559800	3030	2880	194	194
TS-U 6325-11-7	63	25	11,113	54,1	7	260900	661100	3500	3330	219	219
TS-U 6325-11-8	63	25	11,113	54,1	8	294200	762400	3970	3780	244	244
TS-U 6330-11-2	63	30	11,113	54,1	2	86900	164700	990	950	102	102
TS-U 6330-11-3	63	30	11,113	54,1	3	123100	265700	1540	1470	132	132
TS-U 6330-11-4	63	30	11,113	54,1	4	157600	361400	2030	1950	162	162
TS-U 6330-11-5	63	30	11,113	54,1	5	193000	462400	2550	2440	192	192
TS-U 6330-11-6	63	30	11,113	54,1	6	227500	563300	3040	2910	222	222
TS-U 6330-11-7	63	30	11,113	54,1	7	261200	664300	3500	3360	252	252
TS-U 6330-11-8	63	30	11,113	54,1	8	293000	760000	3940	3780	276	276
TS-U 6340-11-2	63	40	11,113	54,1	2	86000	163400	980	950	119	119
TS-U 6340-11-3	63	40	11,113	54,1	3	121800	263600	1510	1460	159	159
TS-U 6340-11-4	63	40	11,113	54,1	4	157500	363800	2020	1960	199	199
TS-U 6340-11-5	63	40	11,113	54,1	5	192400	463900	2530	2450	239	239
TS-U 6340-11-6	63	40	11,113	54,1	6	226500	564100	3010	2920	273	273
TS-U 6350-11-2	63	50	11,113	54,1	2	86700	167000	980	960	135	135
TS-U 6350-11-3	63	50	11,113	54,1	3	121800	266200	1510	1470	185	185
TS-U 6350-11-4	63	50	11,113	54,1	4	157000	365300	2010	1960	235	235
TS-S 7010-6-2	70	10	6,35	64,5	2	42200	103700	950	810	72	64
TS-S 7010-6-3	70	10	6,35	64,5	3	57000	155600	1380	1180	84	76
TS-S 7010-6-4	70	10	6,35	64,5	4	72000	207400	1800	1550	95	87
TS-S 7010-6-5	70	10	6,35	64,5	5	86700	259300	2220	1910	105	97
TS-S 7010-6-6	70	10	6,35	64,5	6	101200	311100	2640	2280	115	107
TS-S 7010-6-7	70	10	6,35	64,5	7	115400	363000	3060	2640	125	117
TS-S 7010-6-8	70	10	6,35	64,5	8	129400	414800	3480	3000	136	128
TS-S 7012-8-2	70	12	7,938	64,5	2	53900	117900	850	720	82	74
TS-S 7012-8-3	70	12	7,938	64,5	3	72800	176900	1230	1050	96	88
TS-S 7012-8-4	70	12	7,938	64,5	4	92000	235800	1610	1380	109	101
TS-S 7012-8-5	70	12	7,938	64,5	5	110900	294800	1990	1710	121	113

* C_a and C_{oa} : Modified static and dynamic load capacities, calculated according to DIN 69051/4 standard and ISO3408/5. See pages 39 and 43.

** $R_{b/t}$: Rigidity of the balls contact zone for an external force 20% of C_a . See page 46. For different forces, multiply by $\sqrt[3]{F/0,2 C_a}$

*** R_{nu} : Total rigidity of the complete nut. It must be multiplied by the factor f_{ar} , which depends on the manufacturing tolerance. See page 48.

Nut dimensions										Grease quantity TS 'steel ball'	Ball screw reference
$D_{1, std}$	$D_{1, min}$	D_4	D_6	M	D_5	L_7	L_1	L_8	L_9	$Q_{gr, real, TS} (cm^3)$	TSB Flanged single nut TSL Cylindrical single nut Recirculation S and U
105		125	145	M12	13,5	25	25	110	127,5	37	TS_-U 6320-11-2
105		125	145	M12	13,5	25	25	110	127,5	45	TS_-U 6320-11-3
105		125	145	M12	13,5	25	25	110	127,5	54	TS_-U 6320-11-4
105		125	145	M12	13,5	25	25	110	127,5	62	TS_-U 6320-11-5
105		125	145	M12	13,5	25	25	110	127,5	71	TS_-U 6320-11-6
105		125	145	M12	13,5	25	25	110	127,5	80	TS_-U 6320-11-7
105		125	145	M12	13,5	25	25	110	127,5	90	TS_-U 6320-11-8
105		125	145	M12	13,5	25	25	110	127,5	37	TS_-U 6325-11-2
105		125	145	M12	13,5	25	25	110	127,5	47	TS_-U 6325-11-3
105		125	145	M12	13,5	25	25	110	127,5	57	TS_-U 6325-11-4
105		125	145	M12	13,5	25	25	110	127,5	67	TS_-U 6325-11-5
105		125	145	M12	13,5	25	25	110	127,5	78	TS_-U 6325-11-6
105		125	145	M12	13,5	25	25	110	127,5	89	TS_-U 6325-11-7
105		125	145	M12	13,5	25	25	110	127,5	100	TS_-U 6325-11-8
105		125	145	M12	13,5	25	25	110	127,5	38	TS_-U 6330-11-2
105		125	145	M12	13,5	25	25	110	127,5	49	TS_-U 6330-11-3
105		125	145	M12	13,5	25	25	110	127,5	61	TS_-U 6330-11-4
105		125	145	M12	13,5	25	25	110	127,5	73	TS_-U 6330-11-5
105		125	145	M12	13,5	25	25	110	127,5	85	TS_-U 6330-11-6
105		125	145	M12	13,5	25	25	110	127,5	98	TS_-U 6330-11-7
105		125	145	M12	13,5	25	25	110	127,5	107	TS_-U 6330-11-8
105		125	145	M12	13,5	25	25	110	127,5	42	TS_-U 6340-11-2
105		125	145	M12	13,5	25	25	110	127,5	57	TS_-U 6340-11-3
105		125	145	M12	13,5	25	25	110	127,5	72	TS_-U 6340-11-4
105		125	145	M12	13,5	25	25	110	127,5	87	TS_-U 6340-11-5
105		125	145	M12	13,5	25	25	110	127,5	99	TS_-U 6340-11-6
105		125	145	M12	13,5	25	25	110	127,5	45	TS_-U 6350-11-2
105		125	145	M12	13,5	25	25	110	127,5	64	TS_-U 6350-11-3
105		125	145	M12	13,5	25	25	110	127,5	83	TS_-U 6350-11-4
105	(95)	123 (113)	140 (130)	M10	11	18	25	110 (100)	125 (115)	22	TS_-S 7010-6-2
105	(95)	123 (113)	140 (130)	M10	11	18	25	110 (100)	125 (115)	26	TS_-S 7010-6-3
105	(95)	123 (113)	140 (130)	M10	11	18	25	110 (100)	125 (115)	29	TS_-S 7010-6-4
105	(95)	123 (113)	140 (130)	M10	11	18	25	110 (100)	125 (115)	31	TS_-S 7010-6-5
105	(95)	123 (113)	140 (130)	M10	11	18	25	110 (100)	125 (115)	34	TS_-S 7010-6-6
105	(95)	123 (113)	140 (130)	M10	11	18	25	110 (100)	125 (115)	36	TS_-S 7010-6-7
105	(95)	123 (113)	140 (130)	M10	11	18	25	110 (100)	125 (115)	39	TS_-S 7010-6-8
105	(95)	125 (115)	145 (135)	M12	13,5	20	25	110 (100)	127,5 (117,5)	36	TS_-S 7012-8-2
105	(95)	125 (115)	145 (135)	M12	13,5	20	25	110 (100)	127,5 (117,5)	43	TS_-S 7012-8-3
105	(95)	125 (115)	145 (135)	M12	13,5	20	25	110 (100)	127,5 (117,5)	49	TS_-S 7012-8-4
105	(95)	125 (115)	145 (135)	M12	13,5	20	25	110 (100)	127,5 (117,5)	54	TS_-S 7012-8-5

Key dimensions of the cylindrical nut: N, M, Y are obtained in the tables of page 38 of the catalogue.

SHUTON advises to use the dimensions of the tables, although it is possible to manufacture ball screw with other dimensions. In brackets () second options. Smaller nut diameters than the first option of the table can reduce the rigidity of the assembly between 5 and 10%.

Please consult SHUTON.

ATR, Single Nut

Ball screw reference	Nominal diameter	Lead	Ball diameter	Root diameter	Circuits	Dynamic load capacity	Static load capacity [kN]	Rigidity of ball contact zone	Rigidity of nut, with $F_{ext}:20\%C_a$	Nut length	
										d_0	P_h
TSB Flanged single nut TSL Cylindrical single nut Recirculation S and U	d_0	P_h	D_w	d_2	$i (le)$	$C_a (N)$	$C_{oa} (N)$	$R_{b/t} (N/\mu m)$	$R_{nut} (N/\mu m)$	<i>TSB</i>	<i>TSL</i>
TS_S 7012-8-6	70	12	7,938	64,5	6	129400	353700	2360	2040	134	126
TS_S 7012-8-7	70	12	7,938	64,5	7	147500	412700	2740	2360	146	138
TS_S 7012-8-8	70	12	7,938	64,5	8	165400	471600	3110	2680	158	150
TS_S 7016-8-2	70	16	7,938	64,5	2	53800	117800	850	750	90	82
TS_S 7016-8-3	70	16	7,938	64,5	3	72700	176700	1230	1090	109	101
TS_S 7016-8-4	70	16	7,938	64,5	4	91900	235500	1610	1430	126	118
TS_S 7016-8-5	70	16	7,938	64,5	5	110700	294400	1980	1770	143	135
TS_S 7016-8-6	70	16	7,938	64,5	6	129200	353300	2360	2110	159	151
TS_S 7016-8-7	70	16	7,938	64,5	7	147300	412200	2730	2440	175	167
TS_S 7016-8-8	70	16	7,938	64,5	8	165100	471100	3100	2770	192	184
TS_S 7020-8-2	70	20	7,938	64,5	2	53700	117600	840	770	101	93
TS_S 7020-8-3	70	20	7,938	64,5	3	72600	176400	1220	1110	124	116
TS_S 7020-8-4	70	20	7,938	64,5	4	91700	235200	1600	1460	146	138
TS_S 7020-8-5	70	20	7,938	64,5	5	110500	294000	1980	1800	167	159
TS_S 7020-8-6	70	20	7,938	64,5	6	129000	352800	2350	2150	188	180
TS_S 7020-8-7	70	20	7,938	64,5	7	147100	411600	2720	2490	208	200
TS_U 7010-6-2	70	10	6,35	64,5	2	42200	103700	930	790	56	56
TS_U 7010-6-3	70	10	6,35	64,5	3	58100	160400	1380	1180	66	66
TS_U 7010-6-4	70	10	6,35	64,5	4	74200	217100	1830	1570	76	76
TS_U 7010-6-5	70	10	6,35	64,5	5	90000	273800	2250	1930	86	86
TS_U 7012-8-2	70	12	7,938	63,3	2	59100	135300	1050	930	66	66
TS_U 7012-8-3	70	12	7,938	63,3	3	82600	213800	1590	1400	78	78
TS_U 7012-8-4	70	12	7,938	63,3	4	105500	289600	2100	1850	90	90
TS_U 7012-8-5	70	12	7,938	63,3	5	127900	365400	2600	2290	102	102
TS_U 7012-8-6	70	12	7,938	63,3	6	150500	443900	3100	2740	114	114
TS_U 7015-8-2	70	15	7,938	63,3	2	59000	135200	1050	950	71	71
TS_U 7015-8-3	70	15	7,938	63,3	3	82500	213700	1590	1430	86	86
TS_U 7015-8-4	70	15	7,938	63,3	4	105400	289400	2090	1890	101	101
TS_U 7015-8-5	70	15	7,938	63,3	5	127800	365100	2590	2350	116	116
TS_U 7015-8-6	70	15	7,938	63,3	6	150400	443500	3090	2800	131	131
TS_U 7016-8-2	70	16	7,938	63,3	2	59000	135200	1050	950	73	73
TS_U 7016-8-3	70	16	7,938	63,3	3	82500	213600	1590	1440	89	89
TS_U 7016-8-4	70	16	7,938	63,3	4	105300	289300	2090	1900	105	105
TS_U 7016-8-5	70	16	7,938	63,3	5	127800	365000	2590	2360	121	121
TS_U 7016-8-6	70	16	7,938	63,3	6	150300	443400	3090	2820	137	137
TS_U 7020-8-2	70	20	7,938	63,3	2	58900	135000	1050	970	80	80
TS_U 7020-8-3	70	20	7,938	63,3	3	82400	213300	1580	1470	100	100
TS_U 7020-8-4	70	20	7,938	63,3	4	105200	288900	2090	1930	120	120
TS_U 7020-8-5	70	20	7,938	63,3	5	128200	367200	2600	2410	140	140
TS_U 7020-8-6	70	20	7,938	63,3	6	150000	442800	3080	2860	160	160

* C_a and C_{oa} : Modified static and dynamic load capacities, calculated according to DIN 69051/4 standard and ISO3408/5. See pages 39 and 43.

** $R_{b/t}$: Rigidity of the balls contact zone for an external force 20% of C_a . See page 46. For different forces, multiply by $\sqrt[3]{F/0,2 C_a}$

*** R_{nu} : Total rigidity of the complete nut. It must be multiplied by the factor f_{ar} , which depends on the manufacturing tolerance. See page 48.

Nut dimensions										Grease quantity TS 'steel ball'	Ball screw reference
$D_{1, std}$	$D_{1, min}$	D_4	D_6	M	D_5	L_7	L_1	L_8	L_9	$Q_{gr, real, TS} (cm^3)$	TSB Flanged single nut TSL Cylindrical single nut Recirculation S and U
105	(95)	125 (115)	145 (135)	M12	13,5	20	25	110 (100)	127,5 (117,5)	59	TS_-S 7012-8-6
105	(95)	125 (115)	145 (135)	M12	13,5	20	25	110 (100)	127,5 (117,5)	65	TS_-S 7012-8-7
105	(95)	125 (115)	145 (135)	M12	13,5	20	25	110 (100)	127,5 (117,5)	70	TS_-S 7012-8-8
105	(95)	125 (115)	145 (135)	M12	13,5	20	25	110 (100)	127,5 (117,5)	36	TS_-S 7016-8-2
105	(95)	125 (115)	145 (135)	M12	13,5	20	25	110 (100)	127,5 (117,5)	45	TS_-S 7016-8-3
105	(95)	125 (115)	145 (135)	M12	13,5	20	25	110 (100)	127,5 (117,5)	52	TS_-S 7016-8-4
105	(95)	125 (115)	145 (135)	M12	13,5	20	25	110 (100)	127,5 (117,5)	60	TS_-S 7016-8-5
105	(95)	125 (115)	145 (135)	M12	13,5	20	25	110 (100)	127,5 (117,5)	66	TS_-S 7016-8-6
105	(95)	125 (115)	145 (135)	M12	13,5	20	25	110 (100)	127,5 (117,5)	73	TS_-S 7016-8-7
105	(95)	125 (115)	145 (135)	M12	13,5	20	25	110 (100)	127,5 (117,5)	80	TS_-S 7016-8-8
105	(95)	125 (115)	145 (135)	M12	13,5	20	25	110 (100)	127,5 (117,5)	39	TS_-S 7020-8-2
105	(95)	125 (115)	145 (135)	M12	13,5	20	25	110 (100)	127,5 (117,5)	49	TS_-S 7020-8-3
105	(95)	125 (115)	145 (135)	M12	13,5	20	25	110 (100)	127,5 (117,5)	59	TS_-S 7020-8-4
105	(95)	125 (115)	145 (135)	M12	13,5	20	25	110 (100)	127,5 (117,5)	68	TS_-S 7020-8-5
105	(95)	125 (115)	145 (135)	M12	13,5	20	25	110 (100)	127,5 (117,5)	77	TS_-S 7020-8-6
105	(95)	125 (115)	145 (135)	M12	13,5	20	25	110 (100)	127,5 (117,5)	85	TS_-S 7020-8-7
105	(95)	123 (113)	140 (130)	M10	11	20	25	110 (100)	125 (115)	14	TS_-U 7010-6-2
105	(95)	123 (113)	140 (130)	M10	11	20	25	110 (100)	125 (115)	16	TS_-U 7010-6-3
105	(95)	123 (113)	140 (130)	M10	11	20	25	110 (100)	125 (115)	19	TS_-U 7010-6-4
105	(95)	123 (113)	140 (130)	M10	11	20	25	110 (100)	125 (115)	21	TS_-U 7010-6-5
105		125	145	M12	13,5	20	25	110	127,5	21	TS_-U 7012-8-2
105		125	145	M12	13,5	20	25	110	127,5	25	TS_-U 7012-8-3
105		125	145	M12	13,5	20	25	110	127,5	29	TS_-U 7012-8-4
105		125	145	M12	13,5	20	25	110	127,5	33	TS_-U 7012-8-5
105		125	145	M12	13,5	20	25	110	127,5	37	TS_-U 7012-8-6
105		125	145	M12	13,5	20	25	110	127,5	20	TS_-U 7015-8-2
105		125	145	M12	13,5	20	25	110	127,5	24	TS_-U 7015-8-3
105		125	145	M12	13,5	20	25	110	127,5	29	TS_-U 7015-8-4
105		125	145	M12	13,5	20	25	110	127,5	34	TS_-U 7015-8-5
105		125	145	M12	13,5	20	25	110	127,5	39	TS_-U 7015-8-6
105		125	145	M12	13,5	20	25	110	127,5	20	TS_-U 7016-8-2
105		125	145	M12	13,5	20	25	110	127,5	25	TS_-U 7016-8-3
105		125	145	M12	13,5	20	25	110	127,5	30	TS_-U 7016-8-4
105		125	145	M12	13,5	20	25	110	127,5	35	TS_-U 7016-8-5
105		125	145	M12	13,5	20	25	110	127,5	39	TS_-U 7016-8-6
105		125	145	M12	13,5	20	25	110	127,5	20	TS_-U 7020-8-2
105		125	145	M12	13,5	20	25	110	127,5	26	TS_-U 7020-8-3
105		125	145	M12	13,5	20	25	110	127,5	32	TS_-U 7020-8-4
105		125	145	M12	13,5	20	25	110	127,5	37	TS_-U 7020-8-5
105		125	145	M12	13,5	20	25	110	127,5	43	TS_-U 7020-8-6

Key dimensions of the cylindrical nut: N, M, Y are obtained in the tables of page 38 of the catalogue.

SHUTON advises to use the dimensions of the tables, although it is possible to manufacture ball screw with other dimensions. In brackets () second options. Smaller nut diameters than the first option of the table can reduce the rigidity of the assembly between 5 and 10%.

Please consult SHUTON.

ATR, Single Nut

Ball screw reference	Nominal diameter	Lead	Ball diameter	Root diameter	Circuits	Dynamic load capacity	Static load capacity [kN]	Rigidity of ball contact zone	Rigidity of nut, with $F_{ext}:20\%C_a$	Nut length	
										d_0	P_h
TSB Flanged single nut TSL Cylindrical single nut Recirculation S and U	d_0	P_h	D_w	d_2	$i (le)$	$C_a (N)$	$C_{oa} (N)$	$R_{b/t} (N/\mu m)$	$R_{nut} (N/\mu m)$	TSB	TSL
TS-U 7025-8-2	70	25	7,938	63,3	2	58700	134700	1040	980	89	89
TS-U 7025-8-3	70	25	7,938	63,3	3	82100	212800	1580	1480	114	114
TS-U 7025-8-4	70	25	7,938	63,3	4	104900	288200	2080	1950	139	139
TS-U 7025-8-5	70	25	7,938	63,3	5	127800	366400	2590	2440	164	164
TS-U 7025-8-6	70	25	7,938	63,3	6	149600	441800	3070	2890	189	189
TS-U 7030-8-2	70	30	7,938	63,3	2	59300	137000	1050	1000	98	98
TS-U 7030-8-3	70	30	7,938	63,3	3	81800	212200	1570	1490	128	128
TS-U 7030-8-4	70	30	7,938	63,3	4	105100	290200	2080	1980	158	158
TS-U 7030-8-5	70	30	7,938	63,3	5	127300	365400	2580	2450	188	188
TS-U 7030-8-6	70	30	7,938	63,3	6	149700	443300	3070	2920	218	218
TS-U 7040-8-2	70	40	7,938	63,3	2	58800	136100	1040	1000	116	116
TS-U 7040-8-3	70	40	7,938	63,3	3	81800	213500	1560	1500	156	156
TS-U 7040-8-4	70	40	7,938	63,3	4	104200	288200	2050	1980	196	196
TS-U 7040-8-5	70	40	7,938	63,3	5	126800	365600	2560	2460	236	236
TS-U 7040-8-6	70	40	7,938	63,3	6	149000	443000	3040	2930	276	276
TS-U 7050-8-2	70	50	7,938	63,3	2	58100	134900	1020	990	136	136
TS-U 7050-8-3	70	50	7,938	63,3	3	80900	211700	1540	1490	186	186
TS-U 7050-8-4	70	50	7,938	63,3	4	103700	288400	2030	1970	236	236
TS-U 7016-9-2	70	16	9,525	62,2	2	75800	161200	1080	990	81	81
TS-U 7016-9-3	70	16	9,525	62,2	3	106200	255500	1630	1480	97	97
TS-U 7016-9-4	70	16	9,525	62,2	4	136500	349900	2180	1980	113	113
TS-U 7016-9-5	70	16	9,525	62,2	5	166300	444200	2700	2460	129	129
TS-U 7016-9-6	70	16	9,525	62,2	6	194400	534600	3180	2900	145	145
TS-U 7016-9-7	70	16	9,525	62,2	7	222900	629000	3660	3350	161	161
TS-U 7016-9-8	70	16	9,525	62,2	8	250900	723300	4140	3790	177	177
TS-U 7020-9-2	70	20	9,525	62,2	2	75600	160900	1080	1000	88	88
TS-U 7020-9-3	70	20	9,525	62,2	3	106000	255200	1620	1510	108	108
TS-U 7020-9-4	70	20	9,525	62,2	4	136300	349400	2170	2010	128	128
TS-U 7020-9-5	70	20	9,525	62,2	5	166000	443600	2690	2500	148	148
TS-U 7020-9-6	70	20	9,525	62,2	6	195000	537800	3190	2970	168	168
TS-U 7020-9-7	70	20	9,525	62,2	7	222500	628100	3650	3400	188	188
TS-U 7020-9-8	70	20	9,525	62,2	8	250400	722300	4130	3850	208	208
TS-U 7025-9-2	70	25	9,525	62,2	2	75400	160600	1070	1010	96	96
TS-U 7025-9-3	70	25	9,525	62,2	3	105700	254600	1620	1520	121	121
TS-U 7025-9-4	70	25	9,525	62,2	4	135900	348600	2160	2030	146	146
TS-U 7025-9-5	70	25	9,525	62,2	5	165500	442600	2680	2520	171	171
TS-U 7025-9-6	70	25	9,525	62,2	6	194500	536600	3180	3000	196	196
TS-U 7025-9-7	70	25	9,525	62,2	7	222800	630600	3660	3450	221	221
TS-U 7025-9-8	70	25	9,525	62,2	8	250600	724700	4140	3900	246	246
TS-U 7030-9-2	70	30	9,525	62,2	2	75200	160200	1070	1010	104	104

* C_a and C_{oa} : Modified static and dynamic load capacities, calculated according to DIN 69051/4 standard and ISO3408/5. See pages 39 and 43.

** $R_{b/t}$: Rigidity of the balls contact zone for an external force 20% of C_a . See page 46. For different forces, multiply by $\sqrt[3]{F/0,2 C_a}$

*** R_{nu} : Total rigidity of the complete nut. It must be multiplied by the factor f_{ar} , which depends on the manufacturing tolerance. See page 48.

Nut dimensions										Grease quantity TS 'steel ball'	Ball screw reference
$D_{1, std}$	$D_{1, min}$	D_4	D_6	M	D_5	L_7	L_1	L_8	L_9	$Q_{gr, real, TS} (cm^3)$	TSB Flanged single nut TSL Cylindrical single nut Recirculation S and U
105		125	145	M12	13,5	20	25	110	127,5	21	TS_-U 7025-8-2
105		125	145	M12	13,5	20	25	110	127,5	28	TS_-U 7025-8-3
105		125	145	M12	13,5	20	25	110	127,5	35	TS_-U 7025-8-4
105		125	145	M12	13,5	20	25	110	127,5	42	TS_-U 7025-8-5
105		125	145	M12	13,5	20	25	110	127,5	49	TS_-U 7025-8-6
105		125	145	M12	13,5	20	25	110	127,5	22	TS_-U 7030-8-2
105		125	145	M12	13,5	20	25	110	127,5	30	TS_-U 7030-8-3
105		125	145	M12	13,5	20	25	110	127,5	38	TS_-U 7030-8-4
105		125	145	M12	13,5	20	25	110	127,5	46	TS_-U 7030-8-5
105		125	145	M12	13,5	20	25	110	127,5	54	TS_-U 7030-8-6
105		125	145	M12	13,5	20	25	110	127,5	26	TS_-U 7040-8-2
105		125	145	M12	13,5	20	25	110	127,5	36	TS_-U 7040-8-3
105		125	145	M12	13,5	20	25	110	127,5	46	TS_-U 7040-8-4
105		125	145	M12	13,5	20	25	110	127,5	56	TS_-U 7040-8-5
105		125	145	M12	13,5	20	25	110	127,5	67	TS_-U 7040-8-6
105		125	145	M12	13,5	20	25	110	127,5	30	TS_-U 7050-8-2
105		125	145	M12	13,5	20	25	110	127,5	42	TS_-U 7050-8-3
105		125	145	M12	13,5	20	25	110	127,5	55	TS_-U 7050-8-4
110		130	150	M12	13,5	25	25	115	132,5	31	TS_-U 7016-9-2
110		130	150	M12	13,5	25	25	115	132,5	37	TS_-U 7016-9-3
110		130	150	M12	13,5	25	25	115	132,5	43	TS_-U 7016-9-4
110		130	150	M12	13,5	25	25	115	132,5	49	TS_-U 7016-9-5
110		130	150	M12	13,5	25	25	115	132,5	56	TS_-U 7016-9-6
110		130	150	M12	13,5	25	25	115	132,5	63	TS_-U 7016-9-7
110		130	150	M12	13,5	25	25	115	132,5	70	TS_-U 7016-9-8
110		130	150	M12	13,5	25	25	115	132,5	30	TS_-U 7020-9-2
110		130	150	M12	13,5	25	25	115	132,5	38	TS_-U 7020-9-3
110		130	150	M12	13,5	25	25	115	132,5	45	TS_-U 7020-9-4
110		130	150	M12	13,5	25	25	115	132,5	53	TS_-U 7020-9-5
110		130	150	M12	13,5	25	25	115	132,5	60	TS_-U 7020-9-6
110		130	150	M12	13,5	25	25	115	132,5	69	TS_-U 7020-9-7
110		130	150	M12	13,5	25	25	115	132,5	77	TS_-U 7020-9-8
110		130	150	M12	13,5	25	25	115	132,5	30	TS_-U 7025-9-2
110		130	150	M12	13,5	25	25	115	132,5	39	TS_-U 7025-9-3
110		130	150	M12	13,5	25	25	115	132,5	48	TS_-U 7025-9-4
110		130	150	M12	13,5	25	25	115	132,5	57	TS_-U 7025-9-5
110		130	150	M12	13,5	25	25	115	132,5	67	TS_-U 7025-9-6
110		130	150	M12	13,5	25	25	115	132,5	77	TS_-U 7025-9-7
110		130	150	M12	13,5	25	25	115	132,5	86	TS_-U 7025-9-8
110		130	150	M12	13,5	25	25	115	132,5	31	TS_-U 7030-9-2

Key dimensions of the cylindrical nut: N, M, Y are obtained in the tables of page 38 of the catalogue.

SHUTON advises to use the dimensions of the tables, although it is possible to manufacture ball screw with other dimensions. In brackets () second options. Smaller nut diameters than the first option of the table can reduce the rigidity of the assembly between 5 and 10%.

Please consult SHUTON.

ATR, Single Nut

Ball screw reference	Nominal diameter	Lead	Ball diameter	Root diameter	Circuits	Dynamic load capacity	Static load capacity [kN]	Rigidity of ball contact zone	Rigidity of nut, with $F_{ext}:20\%C_a$	Nut length	
										d_0	P_h
TSB Flanged single nut TSL Cylindrical single nut Recirculation S and U	d_0	P_h	D_w	d_2	$i (le)$	$C_a (N)$	$C_{oa} (N)$	$R_{b/t} (N/\mu m)$	$R_{nut} (N/\mu m)$	TSB	TSL
TS-U 7030-9-3	70	30	9,525	62,2	3	105300	253900	1610	1530	134	134
TS-U 7030-9-4	70	30	9,525	62,2	4	135400	347700	2150	2040	164	164
TS-U 7030-9-5	70	30	9,525	62,2	5	164900	441500	2660	2540	194	194
TS-U 7030-9-6	70	30	9,525	62,2	6	193800	535200	3160	3010	224	224
TS-U 7030-9-7	70	30	9,525	62,2	7	222000	629000	3640	3470	254	254
TS-U 7030-9-8	70	30	9,525	62,2	8	249800	722700	4110	3920	274	274
TS-U 7040-9-2	70	40	9,525	62,2	2	75700	163000	1080	1040	121	121
TS-U 7040-9-3	70	40	9,525	62,2	3	105500	256100	1610	1550	161	161
TS-U 7040-9-4	70	40	9,525	62,2	4	135300	349300	2140	2060	201	201
TS-U 7040-9-5	70	40	9,525	62,2	5	164500	442400	2650	2550	241	241
TS-U 7040-9-6	70	40	9,525	62,2	6	193100	535500	3140	3030	271	271
TS-U 7050-9-2	70	50	9,525	62,2	2	74900	161600	1060	1030	138	138
TS-U 7050-9-3	70	50	9,525	62,2	3	104300	254000	1580	1530	188	188
TS-U 7050-9-4	70	50	9,525	62,2	4	134800	350200	2120	2060	238	238
TS-S 8010-6-2	80	10	6,35	74,5	2	44900	120500	1070	880	74	64
TS-S 8010-6-3	80	10	6,35	74,5	3	60600	180700	1550	1290	86	76
TS-S 8010-6-4	80	10	6,35	74,5	4	76600	240900	2030	1690	95	87
TS-S 8010-6-5	80	10	6,35	74,5	5	92400	301100	2510	2100	107	97
TS-S 8010-6-6	80	10	6,35	74,5	6	107800	361400	2980	2490	115	107
TS-S 8010-6-7	80	10	6,35	74,5	7	122900	421600	3450	2890	125	117
TS-S 8010-6-8	80	10	6,35	74,5	8	137700	481800	3920	3290	135	128
TS-S 8012-8-2	80	12	7,938	74,5	2	57800	137600	960	820	87	74
TS-S 8012-8-3	80	12	7,938	74,5	3	78000	206300	1400	1200	101	88
TS-S 8012-8-4	80	12	7,938	74,5	4	98600	275100	1830	1570	114	101
TS-S 8012-8-5	80	12	7,938	74,5	5	118800	343900	2260	1940	127	114
TS-S 8012-8-6	80	12	7,938	74,5	6	138600	412700	2680	2310	139	126
TS-S 8012-8-7	80	12	7,938	74,5	7	158100	481500	3110	2680	151	138
TS-S 8012-8-8	80	12	7,938	74,5	8	177200	550300	3530	3040	163	150
TS-S 8016-8-2	80	16	7,938	74,5	2	57700	137400	960	850	95	82
TS-S 8016-8-3	80	16	7,938	74,5	3	77900	206200	1390	1240	114	101
TS-S 8016-8-4	80	16	7,938	74,5	4	98500	274900	1820	1620	131	118
TS-S 8016-8-5	80	16	7,938	74,5	5	118700	343600	2250	2010	148	135
TS-S 8016-8-6	80	16	7,938	74,5	6	138500	412300	2680	2390	164	151
TS-S 8016-8-7	80	16	7,938	74,5	7	157900	481100	3100	2770	180	167
TS-S 8016-8-8	80	16	7,938	74,5	8	177000	549800	3520	3150	197	184
TS-S 8020-9-2	80	20	9,525	73,3	2	73900	163700	980	880	109	97
TS-S 8020-9-3	80	20	9,525	73,3	3	99800	245600	1420	1280	132	121
TS-S 8020-9-4	80	20	9,525	73,3	4	126200	327500	1860	1690	154	142
TS-S 8020-9-5	80	20	9,525	73,3	5	152000	409400	2300	2080	175	163
TS-S 8020-9-6	80	20	9,525	73,3	6	177400	491200	2730	2480	196	184

* C_a and C_{oa} : Modified static and dynamic load capacities, calculated according to DIN 69051/4 standard and ISO3408/5. See pages 39 and 43.

** $R_{b/t}$: Rigidity of the balls contact zone for an external force 20% of C_a . See page 46. For different forces, multiply by $\sqrt[3]{F/0,2 C_a}$

*** R_{nu} : Total rigidity of the complete nut. It must be multiplied by the factor f_{ar} , which depends on the manufacturing tolerance. See page 48.

Nut dimensions										Grease quantity TS 'steel ball'	Ball screw reference
$D_{1, std}$	$D_{1, min}$	D_4	D_6	M	D_5	L_7	L_1	L_8	L_9	$Q_{gr, real, TS} (cm^3)$	TSB Flanged single nut TSL Cylindrical single nut Recirculation S and U
110		130	150	M12	13,5	25	25	115	132,5	42	TS_-U 7030-9-3
110		130	150	M12	13,5	25	25	115	132,5	52	TS_-U 7030-9-4
110		130	150	M12	13,5	25	25	115	132,5	63	TS_-U 7030-9-5
110		130	150	M12	13,5	25	25	115	132,5	74	TS_-U 7030-9-6
110		130	150	M12	13,5	25	25	115	132,5	85	TS_-U 7030-9-7
110		130	150	M12	13,5	25	25	115	132,5	91	TS_-U 7030-9-8
110		130	150	M12	13,5	25	25	115	132,5	35	TS_-U 7040-9-2
110		130	150	M12	13,5	25	25	115	132,5	48	TS_-U 7040-9-3
110		130	150	M12	13,5	25	25	115	132,5	62	TS_-U 7040-9-4
110		130	150	M12	13,5	25	25	115	132,5	75	TS_-U 7040-9-5
110		130	150	M12	13,5	25	25	115	132,5	84	TS_-U 7040-9-6
110		130	150	M12	13,5	25	25	115	132,5	39	TS_-U 7050-9-2
110		130	150	M12	13,5	25	25	115	132,5	56	TS_-U 7050-9-3
110		130	150	M12	13,5	25	25	115	132,5	72	TS_-U 7050-9-4
115	(105)	135 (125)	155 (145)	M12	13,5	20	16	120 (110)	137,5 (127,5)	26	TS_-S 8010-6-2
115	(105)	135 (125)	155 (145)	M12	13,5	20	16	120 (110)	137,5 (127,5)	30	TS_-S 8010-6-3
115	(105)	135 (125)	155 (145)	M12	13,5	20	16	120 (110)	137,5 (127,5)	33	TS_-S 8010-6-4
115	(105)	135 (125)	155 (145)	M12	13,5	20	16	120 (110)	137,5 (127,5)	37	TS_-S 8010-6-5
115	(105)	135 (125)	155 (145)	M12	13,5	20	16	120 (110)	137,5 (127,5)	38	TS_-S 8010-6-6
115	(105)	135 (125)	155 (145)	M12	13,5	20	16	120 (110)	137,5 (127,5)	41	TS_-S 8010-6-7
115	(105)	135 (125)	155 (145)	M12	13,5	20	16	120 (110)	137,5 (127,5)	44	TS_-S 8010-6-8
125	(105)	145 (125)	165 (145)	M12	13,5	25	25	130 (110)	147,5 (127,5)	45	TS_-S 8012-8-2
125	(105)	145 (125)	165 (145)	M12	13,5	25	25	130 (110)	147,5 (127,5)	53	TS_-S 8012-8-3
125	(105)	145 (125)	165 (145)	M12	13,5	25	25	130 (110)	147,5 (127,5)	59	TS_-S 8012-8-4
125	(105)	145 (125)	165 (145)	M12	13,5	25	25	130 (110)	147,5 (127,5)	66	TS_-S 8012-8-5
125	(105)	145 (125)	165 (145)	M12	13,5	25	25	130 (110)	147,5 (127,5)	71	TS_-S 8012-8-6
125	(105)	145 (125)	165 (145)	M12	13,5	25	25	130 (110)	147,5 (127,5)	77	TS_-S 8012-8-7
125	(105)	145 (125)	165 (145)	M12	13,5	25	25	130 (110)	147,5 (127,5)	83	TS_-S 8012-8-8
125	(105)	145 (125)	165 (145)	M12	13,5	25	25	130 (110)	147,5 (127,5)	45	TS_-S 8016-8-2
125	(105)	145 (125)	165 (145)	M12	13,5	25	25	130 (110)	147,5 (127,5)	55	TS_-S 8016-8-3
125	(105)	145 (125)	165 (145)	M12	13,5	25	25	130 (110)	147,5 (127,5)	63	TS_-S 8016-8-4
125	(105)	145 (125)	165 (145)	M12	13,5	25	25	130 (110)	147,5 (127,5)	71	TS_-S 8016-8-5
125	(105)	145 (125)	165 (145)	M12	13,5	25	25	130 (110)	147,5 (127,5)	78	TS_-S 8016-8-6
125	(105)	145 (125)	165 (145)	M12	13,5	25	25	130 (110)	147,5 (127,5)	86	TS_-S 8016-8-7
125	(105)	145 (125)	165 (145)	M12	13,5	25	25	130 (110)	147,5 (127,5)	94	TS_-S 8016-8-8
125	(110)	145 (130)	165 (150)	M12	13,5	25	25	130 (115)	147,5 (132,5)	60	TS_-S 8020-9-2
125	(110)	145 (130)	165 (150)	M12	13,5	25	25	130 (115)	147,5 (132,5)	74	TS_-S 8020-9-3
125	(110)	145 (130)	165 (150)	M12	13,5	25	25	130 (115)	147,5 (132,5)	87	TS_-S 8020-9-4
125	(110)	145 (130)	165 (150)	M12	13,5	25	25	130 (115)	147,5 (132,5)	99	TS_-S 8020-9-5
125	(110)	145 (130)	165 (150)	M12	13,5	25	25	130 (115)	147,5 (132,5)	111	TS_-S 8020-9-6

Key dimensions of the cylindrical nut: N, M, Y are obtained in the tables of page 38 of the catalogue.

SHUTON advises to use the dimensions of the tables, although it is possible to manufacture ball screw with other dimensions. In brackets () second options. Smaller nut diameters than the first option of the table can reduce the rigidity of the assembly between 5 and 10%.

Please consult SHUTON.

ATR, Single Nut

Ball screw reference	Nominal diameter	Lead	Ball diameter	Root diameter	Circuits	Dynamic load capacity	Static load capacity [kN]	Rigidity of ball contact zone	Rigidity of nut, with $F_{ext}:20\%C_a$	Nut length	
										d_0	P_h
TSB Flanged single nut TSL Cylindrical single nut Recirculation S and U	d_0	P_h	D_w	d_2	$i (le)$	$C_a (N)$	$C_{oa} (N)$	$R_{b/t} (N/\mu m)$	$R_{nut} (N/\mu m)$	TSB	TSL
TS-S 8020-9-7	80	20	9,525	73,3	7	202300	573100	3160	2870	216	204
TS-S 8020-9-8	80	20	9,525	73,3	8	226800	655000	3590	3260	236	225
TS-U 8012-8-2	80	12	7,938	73,3	2	63200	157800	1200	1050	66	66
TS-U 8012-8-3	80	12	7,938	73,3	3	87300	244900	1770	1560	78	78
TS-U 8012-8-4	80	12	7,938	73,3	4	112200	334700	2350	2070	90	90
TS-U 8012-8-5	80	12	7,938	73,3	5	135900	421800	2900	2560	102	102
TS-U 8012-8-6	80	12	7,938	73,3	6	159200	508900	3440	3040	114	114
TS-U 8015-8-2	80	15	7,938	73,3	2	63200	157700	1190	1080	71	71
TS-U 8015-8-3	80	15	7,938	73,3	3	87200	244800	1760	1590	86	86
TS-U 8015-8-4	80	15	7,938	73,3	4	112100	334500	2350	2120	101	101
TS-U 8015-8-5	80	15	7,938	73,3	5	135800	421500	2900	2620	116	116
TS-U 8015-8-6	80	15	7,938	73,3	6	159000	508600	3430	3110	131	131
TS-U 8016-8-2	80	16	7,938	73,3	2	63100	157700	1190	1080	73	73
TS-U 8016-8-3	80	16	7,938	73,3	3	87200	244700	1760	1600	89	89
TS-U 8016-8-4	80	16	7,938	73,3	4	112000	334400	2350	2130	105	105
TS-U 8016-8-5	80	16	7,938	73,3	5	135800	421400	2900	2640	121	121
TS-U 8016-8-6	80	16	7,938	73,3	6	159000	508500	3430	3120	137	137
TS-U 8016-9-2	80	16	9,525	72,2	2	81800	190000	1220	1100	81	81
TS-U 8016-9-3	80	16	9,525	72,2	3	113500	296800	1830	1650	97	97
TS-U 8016-9-4	80	16	9,525	72,2	4	145300	403700	2430	2200	113	113
TS-U 8016-9-5	80	16	9,525	72,2	5	176600	510500	3000	2710	129	129
TS-U 8016-9-6	80	16	9,525	72,2	6	207100	617400	3560	3220	145	145
TS-U 8016-9-7	80	16	9,525	72,2	7	237000	724200	4100	3720	161	161
TS-U 8020-9-2	80	20	9,525	72,2	2	81700	189800	1220	1120	88	88
TS-U 8020-9-3	80	20	9,525	72,2	3	113400	296500	1820	1680	108	108
TS-U 8020-9-4	80	20	9,525	72,2	4	145100	403200	2430	2240	128	128
TS-U 8020-9-5	80	20	9,525	72,2	5	176300	510000	2990	2760	148	148
TS-U 8020-9-6	80	20	9,525	72,2	6	206800	616700	3550	3280	168	168
TS-U 8020-9-7	80	20	9,525	72,2	7	236700	723400	4100	3780	188	188
TS-U 8025-9-2	80	25	9,525	72,2	2	81500	189400	1210	1140	97	97
TS-U 8025-9-3	80	25	9,525	72,2	3	113100	296000	1820	1700	122	122
TS-U 8025-9-4	80	25	9,525	72,2	4	144800	402500	2420	2260	147	147
TS-U 8025-9-5	80	25	9,525	72,2	5	175900	509100	2980	2790	172	172
TS-U 8025-9-6	80	25	9,525	72,2	6	207200	619600	3560	3340	197	197
TS-U 8025-9-7	80	25	9,525	72,2	7	237000	726200	4100	3850	222	222
TS-U 8030-9-2	80	30	9,525	72,2	2	81300	189000	1210	1140	106	106
TS-U 8030-9-3	80	30	9,525	72,2	3	112800	295400	1810	1710	136	136
TS-U 8030-9-4	80	30	9,525	72,2	4	144400	401700	2410	2280	166	166
TS-U 8030-9-5	80	30	9,525	72,2	5	176400	512000	2990	2830	196	196
TS-U 8030-9-6	80	30	9,525	72,2	6	206700	618300	3550	3360	226	226

* C_a and C_{oa} : Modified static and dynamic load capacities, calculated according to DIN 69051/4 standard and ISO3408/5. See pages 39 and 43.

** $R_{b/t}$: Rigidity of the balls contact zone for an external force 20% of C_a . See page 46. For different forces, multiply by $\sqrt[3]{F/0,2 C_a}$

*** R_{nu} : Total rigidity of the complete nut. It must be multiplied by the factor f_{ar} , which depends on the manufacturing tolerance. See page 48.

Nut dimensions										Grease quantity TS 'steel ball'	Ball screw reference
$D_{I, std}$	$D_{I, min}$	D_4	D_6	M	D_5	L_7	L_1	L_8	L_9	$Q_{gr, real, TS} (cm^3)$	TSB Flanged single nut TSL Cylindrical single nut Recirculation S and U
125	(110)	145 (130)	165 (150)	M12	13,5	25	25	130 (115)	147,5 (132,5)	123	TS_-S 8020-9-7
125	(110)	145 (130)	165 (150)	M12	13,5	25	25	130 (115)	147,5 (132,5)	134	TS_-S 8020-9-8
125	(115)	145 (135)	165 (155)	M12	13,5	25	25	130 (120)	147,5 (137,5)	24	TS_-U 8012-8-2
125	(115)	145 (135)	165 (155)	M12	13,5	25	25	130 (120)	147,5 (137,5)	28	TS_-U 8012-8-3
125	(115)	145 (135)	165 (155)	M12	13,5	25	25	130 (120)	147,5 (137,5)	33	TS_-U 8012-8-4
125	(115)	145 (135)	165 (155)	M12	13,5	25	25	130 (120)	147,5 (137,5)	37	TS_-U 8012-8-5
125	(115)	145 (135)	165 (155)	M12	13,5	25	25	130 (120)	147,5 (137,5)	42	TS_-U 8012-8-6
125	(115)	145 (135)	165 (155)	M12	13,5	25	25	130 (120)	147,5 (137,5)	23	TS_-U 8015-8-2
125	(115)	145 (135)	165 (155)	M12	13,5	25	25	130 (120)	147,5 (137,5)	28	TS_-U 8015-8-3
125	(115)	145 (135)	165 (155)	M12	13,5	25	25	130 (120)	147,5 (137,5)	33	TS_-U 8015-8-4
125	(115)	145 (135)	165 (155)	M12	13,5	25	25	130 (120)	147,5 (137,5)	38	TS_-U 8015-8-5
125	(115)	145 (135)	165 (155)	M12	13,5	25	25	130 (120)	147,5 (137,5)	44	TS_-U 8015-8-6
125	(115)	145 (135)	165 (155)	M12	13,5	25	25	130 (120)	147,5 (137,5)	23	TS_-U 8016-8-2
125	(115)	145 (135)	165 (155)	M12	13,5	25	25	130 (120)	147,5 (137,5)	28	TS_-U 8016-8-3
125	(115)	145 (135)	165 (155)	M12	13,5	25	25	130 (120)	147,5 (137,5)	34	TS_-U 8016-8-4
125	(115)	145 (135)	165 (155)	M12	13,5	25	25	130 (120)	147,5 (137,5)	39	TS_-U 8016-8-5
125	(115)	145 (135)	165 (155)	M12	13,5	25	25	130 (120)	147,5 (137,5)	45	TS_-U 8016-8-6
125	(120)	145 (140)	165 (160)	M12	13,5	25	25	130 (125)	147,5 (142,5)	35	TS_-U 8016-9-2
125	(120)	145 (140)	165 (160)	M12	13,5	25	25	130 (125)	147,5 (142,5)	42	TS_-U 8016-9-3
125	(120)	145 (140)	165 (160)	M12	13,5	25	25	130 (125)	147,5 (142,5)	49	TS_-U 8016-9-4
125	(120)	145 (140)	165 (160)	M12	13,5	25	25	130 (125)	147,5 (142,5)	56	TS_-U 8016-9-5
125	(120)	145 (140)	165 (160)	M12	13,5	25	25	130 (125)	147,5 (142,5)	64	TS_-U 8016-9-6
125	(120)	145 (140)	165 (160)	M12	13,5	25	25	130 (125)	147,5 (142,5)	72	TS_-U 8016-9-7
125	(120)	145 (140)	165 (160)	M12	13,5	25	25	130 (125)	147,5 (142,5)	34	TS_-U 8020-9-2
125	(120)	145 (140)	165 (160)	M12	13,5	25	25	130 (125)	147,5 (142,5)	43	TS_-U 8020-9-3
125	(120)	145 (140)	165 (160)	M12	13,5	25	25	130 (125)	147,5 (142,5)	51	TS_-U 8020-9-4
125	(120)	145 (140)	165 (160)	M12	13,5	25	25	130 (125)	147,5 (142,5)	60	TS_-U 8020-9-5
125	(120)	145 (140)	165 (160)	M12	13,5	25	25	130 (125)	147,5 (142,5)	69	TS_-U 8020-9-6
125	(120)	145 (140)	165 (160)	M12	13,5	25	25	130 (125)	147,5 (142,5)	78	TS_-U 8020-9-7
125	(120)	145 (140)	165 (160)	M12	13,5	25	25	130 (125)	147,5 (142,5)	35	TS_-U 8025-9-2
125	(120)	145 (140)	165 (160)	M12	13,5	25	25	130 (125)	147,5 (142,5)	45	TS_-U 8025-9-3
125	(120)	145 (140)	165 (160)	M12	13,5	25	25	130 (125)	147,5 (142,5)	55	TS_-U 8025-9-4
125	(120)	145 (140)	165 (160)	M12	13,5	25	25	130 (125)	147,5 (142,5)	66	TS_-U 8025-9-5
125	(120)	145 (140)	165 (160)	M12	13,5	25	25	130 (125)	147,5 (142,5)	76	TS_-U 8025-9-6
125	(120)	145 (140)	165 (160)	M12	13,5	25	25	130 (125)	147,5 (142,5)	87	TS_-U 8025-9-7
125	(120)	145 (140)	165 (160)	M12	13,5	25	25	130 (125)	147,5 (142,5)	37	TS_-U 8030-9-2
125	(120)	145 (140)	165 (160)	M12	13,5	25	25	130 (125)	147,5 (142,5)	49	TS_-U 8030-9-3
125	(120)	145 (140)	165 (160)	M12	13,5	25	25	130 (125)	147,5 (142,5)	61	TS_-U 8030-9-4
125	(120)	145 (140)	165 (160)	M12	13,5	25	25	130 (125)	147,5 (142,5)	73	TS_-U 8030-9-5
125	(120)	145 (140)	165 (160)	M12	13,5	25	25	130 (125)	147,5 (142,5)	85	TS_-U 8030-9-6

Key dimensions of the cylindrical nut: N, M, Y are obtained in the tables of page 38 of the catalogue.

SHUTON advises to use the dimensions of the tables, although it is possible to manufacture ball screw with other dimensions. In brackets () second options. Smaller nut diameters than the first option of the table can reduce the rigidity of the assembly between 5 and 10%.

Please consult SHUTON.

ATR, Single Nut

Ball screw reference	Nominal diameter	Lead	Ball diameter	Root diameter	Circuits	Dynamic load capacity	Static load capacity [kN]	Rigidity of ball contact zone	Rigidity of nut, with $F_{ext}:20\%C_a$	Nut length	
										d_0	P_h
TSB Flanged single nut TSL Cylindrical single nut Recirculation S and U	d_0	P_h	D_w	d_2	$i (le)$	$C_a (N)$	$C_{oa} (N)$	$R_{b/t} (N/\mu m)$	$R_{nut} (N/\mu m)$	TSB	TSL
TS-U 8030-9-7	80	30	9,525	72,2	7	236400	724700	4080	3870	256	256
TS-U 8040-9-2	80	40	9,525	72,2	2	80800	188100	1200	1150	123	123
TS-U 8040-9-3	80	40	9,525	72,2	3	113000	297800	1810	1740	163	163
TS-U 8040-9-4	80	40	9,525	72,2	4	144400	403600	2400	2310	203	203
TS-U 8040-9-5	80	40	9,525	72,2	5	175200	509400	2960	2840	243	243
TS-U 8040-9-6	80	40	9,525	72,2	6	206200	619100	3530	3390	283	283
TS-U 8050-9-2	80	50	9,525	72,2	2	81200	190700	1200	1160	140	140
TS-U 8050-9-3	80	50	9,525	72,2	3	112100	295800	1790	1730	190	190
TS-U 8050-9-4	80	50	9,525	72,2	4	144100	404800	2390	2310	240	240
TS-U 8050-9-5	80	50	9,525	72,2	5	174600	509900	2940	2850	290	290
TS-U 8020-11-2	80	20	11,113	71,1	2	99400	217000	1260	1160	87	87
TS-U 8020-11-3	80	20	11,113	71,1	3	140200	347300	1910	1760	107	107
TS-U 8020-11-4	80	20	11,113	71,1	4	179400	472100	2540	2340	127	127
TS-U 8020-11-5	80	20	11,113	71,1	5	217900	596900	3140	2890	147	147
TS-U 8020-11-6	80	20	11,113	71,1	6	256900	727100	3740	3450	167	167
TS-U 8020-11-7	80	20	11,113	71,1	7	293700	851900	4310	3980	187	187
TS-U 8020-11-8	80	20	11,113	71,1	8	331100	982100	4860	4490	207	207
TS-U 8025-11-2	80	25	11,113	71,1	2	99200	216700	1250	1170	96	96
TS-U 8025-11-3	80	25	11,113	71,1	3	139900	346700	1910	1780	121	121
TS-U 8025-11-4	80	25	11,113	71,1	4	179100	471300	2530	2370	146	146
TS-U 8025-11-5	80	25	11,113	71,1	5	218800	601300	3150	2950	171	171
TS-U 8025-11-6	80	25	11,113	71,1	6	256300	725900	3720	3490	196	196
TS-U 8025-11-7	80	25	11,113	71,1	7	294300	855900	4320	4050	221	221
TS-U 8025-11-8	80	25	11,113	71,1	8	330400	980500	4840	4540	246	246
TS-U 8030-11-2	80	30	11,113	71,1	2	99000	216200	1250	1180	104	104
TS-U 8030-11-3	80	30	11,113	71,1	3	139500	346000	1900	1800	134	134
TS-U 8030-11-4	80	30	11,113	71,1	4	178600	470300	2520	2380	164	164
TS-U 8030-11-5	80	30	11,113	71,1	5	218200	600100	3140	2970	194	194
TS-U 8030-11-6	80	30	11,113	71,1	6	255600	724400	3710	3510	224	224
TS-U 8030-11-7	80	30	11,113	71,1	7	293600	854200	4300	4070	254	254
TS-U 8030-11-8	80	30	11,113	71,1	8	329600	978500	4820	4570	284	284
TS-U 8040-11-2	80	40	11,113	71,1	2	99900	220500	1260	1210	121	121
TS-U 8040-11-3	80	40	11,113	71,1	3	138600	344200	1880	1800	161	161
TS-U 8040-11-4	80	40	11,113	71,1	4	178800	473300	2520	2420	201	201
TS-U 8040-11-5	80	40	11,113	71,1	5	218100	602400	3130	3000	241	241
TS-U 8040-11-6	80	40	11,113	71,1	6	255200	726100	3690	3550	281	281
TS-U 8050-11-2	80	50	11,113	71,1	2	99100	219100	1250	1210	138	138
TS-U 8050-11-3	80	50	11,113	71,1	3	138900	347300	1880	1820	188	188
TS-U 8050-11-4	80	50	11,113	71,1	4	178600	475600	2510	2430	238	238
TS-U 8050-11-5	80	50	11,113	71,1	5	216200	598500	3090	2990	288	288

* C_a and C_{oa} : Modified static and dynamic load capacities, calculated according to DIN 69051/4 standard and ISO3408/5. See pages 39 and 43.

** $R_{b/t}$: Rigidity of the balls contact zone for an external force 20% of C_a . See page 46. For different forces, multiply by $\sqrt[3]{F/0,2 C_a}$

*** R_{nu} : Total rigidity of the complete nut. It must be multiplied by the factor f_{ar} , which depends on the manufacturing tolerance. See page 48.

Nut dimensions										Grease quantity TS 'steel ball'	Ball screw reference
$D_{1, std}$	$D_{1, min}$	D_4	D_6	M	D_5	L_7	L_1	L_8	L_9	$Q_{gr, real, TS} (cm^3)$	TSB Flanged single nut TSL Cylindrical single nut Recirculation S and U
125	(120)	145 (140)	165 (160)	M12	13,5	25	25	130 (125)	147,5 (142,5)	98	TS_-U 8030-9-7
125	(120)	145 (140)	165 (160)	M12	13,5	25	25	130 (125)	147,5 (142,5)	41	TS_-U 8040-9-2
125	(120)	145 (140)	165 (160)	M12	13,5	25	25	130 (125)	147,5 (142,5)	56	TS_-U 8040-9-3
125	(120)	145 (140)	165 (160)	M12	13,5	25	25	130 (125)	147,5 (142,5)	71	TS_-U 8040-9-4
125	(120)	145 (140)	165 (160)	M12	13,5	25	25	130 (125)	147,5 (142,5)	87	TS_-U 8040-9-5
125	(120)	145 (140)	165 (160)	M12	13,5	25	25	130 (125)	147,5 (142,5)	103	TS_-U 8040-9-6
125	(120)	145 (140)	165 (160)	M12	13,5	25	25	130 (125)	147,5 (142,5)	45	TS_-U 8050-9-2
125	(120)	145 (140)	165 (160)	M12	13,5	25	25	130 (125)	147,5 (142,5)	64	TS_-U 8050-9-3
125	(120)	145 (140)	165 (160)	M12	13,5	25	25	130 (125)	147,5 (142,5)	83	TS_-U 8050-9-4
125	(120)	145 (140)	165 (160)	M12	13,5	25	25	130 (125)	147,5 (142,5)	102	TS_-U 8050-9-5
125		145	165	M12	13,5	25	25	130	147,5	47	TS_-U 8020-11-2
125		145	165	M12	13,5	25	25	130	147,5	57	TS_-U 8020-11-3
125		145	165	M12	13,5	25	25	130	147,5	68	TS_-U 8020-11-4
125		145	165	M12	13,5	25	25	130	147,5	79	TS_-U 8020-11-5
125		145	165	M12	13,5	25	25	130	147,5	90	TS_-U 8020-11-6
125		145	165	M12	13,5	25	25	130	147,5	101	TS_-U 8020-11-7
125		145	165	M12	13,5	25	25	130	147,5	114	TS_-U 8020-11-8
125		145	165	M12	13,5	25	25	130	147,5	48	TS_-U 8025-11-2
125		145	165	M12	13,5	25	25	130	147,5	60	TS_-U 8025-11-3
125		145	165	M12	13,5	25	25	130	147,5	73	TS_-U 8025-11-4
125		145	165	M12	13,5	25	25	130	147,5	86	TS_-U 8025-11-5
125		145	165	M12	13,5	25	25	130	147,5	99	TS_-U 8025-11-6
125		145	165	M12	13,5	25	25	130	147,5	113	TS_-U 8025-11-7
125		145	165	M12	13,5	25	25	130	147,5	127	TS_-U 8025-11-8
125		145	165	M12	13,5	25	25	130	147,5	49	TS_-U 8030-11-2
125		145	165	M12	13,5	25	25	130	147,5	63	TS_-U 8030-11-3
125		145	165	M12	13,5	25	25	130	147,5	78	TS_-U 8030-11-4
125		145	165	M12	13,5	25	25	130	147,5	93	TS_-U 8030-11-5
125		145	165	M12	13,5	25	25	130	147,5	109	TS_-U 8030-11-6
125		145	165	M12	13,5	25	25	130	147,5	124	TS_-U 8030-11-7
125		145	165	M12	13,5	25	25	130	147,5	141	TS_-U 8030-11-8
125		145	165	M12	13,5	25	25	130	147,5	53	TS_-U 8040-11-2
125		145	165	M12	13,5	25	25	130	147,5	72	TS_-U 8040-11-3
125		145	165	M12	13,5	25	25	130	147,5	91	TS_-U 8040-11-4
125		145	165	M12	13,5	25	25	130	147,5	110	TS_-U 8040-11-5
125		145	165	M12	13,5	25	25	130	147,5	131	TS_-U 8040-11-6
125		145	165	M12	13,5	25	25	130	147,5	58	TS_-U 8050-11-2
125		145	165	M12	13,5	25	25	130	147,5	82	TS_-U 8050-11-3
125		145	165	M12	13,5	25	25	130	147,5	105	TS_-U 8050-11-4
125		145	165	M12	13,5	25	25	130	147,5	129	TS_-U 8050-11-5

Key dimensions of the cylindrical nut: N, M, Y are obtained in the tables of page 38 of the catalogue.

SHUTON advises to use the dimensions of the tables, although it is possible to manufacture ball screw with other dimensions. In brackets () second options. Smaller nut diameters than the first option of the table can reduce the rigidity of the assembly between 5 and 10%.

Please consult SHUTON.

ATR, Single Nut

Ball screw reference	Nominal diameter	Lead	Ball diameter	Root diameter	Circuits	Dynamic load capacity	Static load capacity [kN]	Rigidity of ball contact zone	Rigidity of nut, with $F_{ext}:20\%C_a$	Nut length	
										d_0	P_h
TSB Flanged single nut TSL Cylindrical single nut Recirculation S and U	d_0	P_h	D_w	d_2	$i (le)$	$C_a (N)$	$C_{oa} (N)$	$R_{b/t} (N/\mu m)$	$R_{nut} (N/\mu m)$	TSB	TSL
TS_S 10010-6-2	100	10	6,35	94,5	2	48900	150700	1280	990	76	64
TS_S 10010-6-3	100	10	6,35	94,5	3	66100	226000	1850	1450	88	76
TS_S 10010-6-4	100	10	6,35	94,5	4	83500	301400	2430	1900	99	87
TS_S 10010-6-5	100	10	6,35	94,5	5	100600	376700	3000	2360	109	97
TS_S 10010-6-6	100	10	6,35	94,5	6	117400	452100	3560	2810	120	108
TS_S 10010-6-7	100	10	6,35	94,5	7	133900	527400	4130	3260	130	118
TS_S 10010-6-8	100	10	6,35	94,5	8	150100	602800	4690	3700	140	128
TS_S 10012-8-2	100	12	7,938	94,5	2	64300	176900	1180	970	92	74
TS_S 10012-8-3	100	12	7,938	94,5	3	86900	265400	1710	1410	106	88
TS_S 10012-8-4	100	12	7,938	94,5	4	109800	353900	2240	1850	119	101
TS_S 10012-8-5	100	12	7,938	94,5	5	132300	442300	2770	2290	132	114
TS_S 10012-8-6	100	12	7,938	94,5	6	154400	530800	3290	2730	144	126
TS_S 10012-8-7	100	12	7,938	94,5	7	176100	619300	3810	3160	156	138
TS_S 10012-8-8	100	12	7,938	94,5	8	197400	707700	4330	3590	169	151
TS_S 10016-8-2	100	16	7,938	94,5	2	64300	176800	1180	1010	100	82
TS_S 10016-8-3	100	16	7,938	94,5	3	86800	265300	1710	1470	119	101
TS_S 10016-8-4	100	16	7,938	94,5	4	109700	353700	2240	1930	136	118
TS_S 10016-8-5	100	16	7,938	94,5	5	132200	442100	2760	2390	153	135
TS_S 10016-8-6	100	16	7,938	94,5	6	154300	530500	3290	2850	169	151
TS_S 10016-8-7	100	16	7,938	94,5	7	176000	618900	3810	3300	185	167
TS_S 10016-8-8	100	16	7,938	94,5	8	197200	707300	4320	3750	202	184
TS_S 10020-9-2	100	20	9,525	93,3	2	83500	213700	1220	1070	114	98
TS_S 10020-9-3	100	20	9,525	93,3	3	112700	320500	1770	1560	138	121
TS_S 10020-9-4	100	20	9,525	93,3	4	142400	427400	2320	2040	159	143
TS_S 10020-9-5	100	20	9,525	93,3	5	171600	534200	2860	2530	180	164
TS_S 10020-9-6	100	20	9,525	93,3	6	200300	641000	3400	3010	201	184
TS_S 10020-9-7	100	20	9,525	93,3	7	228400	747900	3940	3480	221	204
TS_S 10020-9-8	100	20	9,525	93,3	8	256000	854700	4470	3960	242	225
TS_U 10012-8-2	100	12	7,938	93,3	2	70300	202900	1460	1240	66	66
TS_U 10012-8-3	100	12	7,938	93,3	3	96600	312600	2150	1830	78	78
TS_U 10012-8-4	100	12	7,938	93,3	4	123100	422200	2820	2420	90	90
TS_U 10015-8-2	100	15	7,938	93,3	2	70200	202800	1450	1280	72	72
TS_U 10015-8-3	100	15	7,938	93,3	3	96500	312400	2140	1890	87	87
TS_U 10015-8-4	100	15	7,938	93,3	4	123000	422100	2820	2490	102	102
TS_U 10016-8-2	100	16	7,938	93,3	2	70200	202800	1450	1290	74	74
TS_U 10016-8-3	100	16	7,938	93,3	3	96500	312400	2140	1900	90	90
TS_U 10016-8-4	100	16	7,938	93,3	4	123000	422000	2820	2500	106	106
TS_U 10016-9-2	100	16	9,525	92,2	2	91100	243600	1500	1320	82	82
TS_U 10016-9-3	100	16	9,525	92,2	3	126100	379400	2220	1960	98	98
TS_U 10016-9-4	100	16	9,525	92,2	4	160400	511200	2930	2580	114	114

* C_a and C_{oa} : Modified static and dynamic load capacities, calculated according to DIN 69051/4 standard and ISO3408/5. See pages 39 and 43.

** $R_{b/t}$: Rigidity of the balls contact zone for an external force 20% of C_a . See page 46. For different forces, multiply by $\sqrt[3]{F/0,2 C_a}$

*** R_{nu} : Total rigidity of the complete nut. It must be multiplied by the factor f_{ar} , which depends on the manufacturing tolerance. See page 48.

Nut dimensions										Grease quantity TS 'steel ball'	Ball screw reference
$D_{1, std}$	$D_{1, min}$	D_4	D_6	M	D_5	L_7	L_1	L_8	L_9	$Q_{gr, real, TS} (cm^3)$	TSB Flanged single nut TSL Cylindrical single nut Recirculation S and U
135	(125)	155 (145)	175 (165)	M12	13,5	22	16	140 (130)	157,5 (147,5)	34	TS_-S 10010-6-2
135	(125)	155 (145)	175 (165)	M12	13,5	22	16	140 (130)	157,5 (147,5)	39	TS_-S 10010-6-3
135	(125)	155 (145)	175 (165)	M12	13,5	22	16	140 (130)	157,5 (147,5)	44	TS_-S 10010-6-4
135	(125)	155 (145)	175 (165)	M12	13,5	22	16	140 (130)	157,5 (147,5)	47	TS_-S 10010-6-5
135	(125)	155 (145)	175 (165)	M12	13,5	22	16	140 (130)	157,5 (147,5)	51	TS_-S 10010-6-6
135	(125)	155 (145)	175 (165)	M12	13,5	22	16	140 (130)	157,5 (147,5)	55	TS_-S 10010-6-7
135	(125)	155 (145)	175 (165)	M12	13,5	22	16	140 (130)	157,5 (147,5)	58	TS_-S 10010-6-8
150	(125)	176 (145)	202 (165)	M16 (M12)	17,5 (13,5)	30	25	155 (130)	178,5 (147,5)	61	TS_-S 10012-8-2
150	(125)	176 (145)	202 (165)	M16 (M12)	17,5 (13,5)	30	25	155 (130)	178,5 (147,5)	70	TS_-S 10012-8-3
150	(125)	176 (145)	202 (165)	M16 (M12)	17,5 (13,5)	30	25	155 (130)	178,5 (147,5)	78	TS_-S 10012-8-4
150	(125)	176 (145)	202 (165)	M16 (M12)	17,5 (13,5)	30	25	155 (130)	178,5 (147,5)	86	TS_-S 10012-8-5
150	(125)	176 (145)	202 (165)	M16 (M12)	17,5 (13,5)	30	25	155 (130)	178,5 (147,5)	93	TS_-S 10012-8-6
150	(125)	176 (145)	202 (165)	M16 (M12)	17,5 (13,5)	30	25	155 (130)	178,5 (147,5)	99	TS_-S 10012-8-7
150	(125)	176 (145)	202 (165)	M16 (M12)	17,5 (13,5)	30	25	155 (130)	178,5 (147,5)	107	TS_-S 10012-8-8
150	(125)	176 (145)	202 (165)	M16 (M12)	17,5 (13,5)	30	25	155 (130)	178,5 (147,5)	60	TS_-S 10016-8-2
150	(125)	176 (145)	202 (165)	M16 (M12)	17,5 (13,5)	30	25	155 (130)	178,5 (147,5)	72	TS_-S 10016-8-3
150	(125)	176 (145)	202 (165)	M16 (M12)	17,5 (13,5)	30	25	155 (130)	178,5 (147,5)	82	TS_-S 10016-8-4
150	(125)	176 (145)	202 (165)	M16 (M12)	17,5 (13,5)	30	25	155 (130)	178,5 (147,5)	92	TS_-S 10016-8-5
150	(125)	176 (145)	202 (165)	M16 (M12)	17,5 (13,5)	30	25	155 (130)	178,5 (147,5)	101	TS_-S 10016-8-6
150	(125)	176 (145)	202 (165)	M16 (M12)	17,5 (13,5)	30	25	155 (130)	178,5 (147,5)	110	TS_-S 10016-8-7
150	(125)	176 (145)	202 (165)	M16 (M12)	17,5 (13,5)	30	25	155 (130)	178,5 (147,5)	120	TS_-S 10016-8-8
150	(130)	176 (150)	202 (170)	M16 (M12)	17,5 (13,5)	30	25	155 (135)	178,5 (152,5)	79	TS_-S 10020-9-2
150	(130)	176 (150)	202 (170)	M16 (M12)	17,5 (13,5)	30	25	155 (135)	178,5 (152,5)	97	TS_-S 10020-9-3
150	(130)	176 (150)	202 (170)	M16 (M12)	17,5 (13,5)	30	25	155 (135)	178,5 (152,5)	112	TS_-S 10020-9-4
150	(130)	176 (150)	202 (170)	M16 (M12)	17,5 (13,5)	30	25	155 (135)	178,5 (152,5)	127	TS_-S 10020-9-5
150	(130)	176 (150)	202 (170)	M16 (M12)	17,5 (13,5)	30	25	155 (135)	178,5 (152,5)	141	TS_-S 10020-9-6
150	(130)	176 (150)	202 (170)	M16 (M12)	17,5 (13,5)	30	25	155 (135)	178,5 (152,5)	155	TS_-S 10020-9-7
150	(130)	176 (150)	202 (170)	M16 (M12)	17,5 (13,5)	30	25	155 (135)	178,5 (152,5)	169	TS_-S 10020-9-8
150	(135)	176 (155)	202 (175)	M16 (M12)	17,5 (13,5)	30	25	155 (140)	178,5 (157,5)	29	TS_-U 10012-8-2
150	(135)	176 (155)	202 (175)	M16 (M12)	17,5 (13,5)	30	25	155 (140)	178,5 (157,5)	35	TS_-U 10012-8-3
150	(135)	176 (155)	202 (175)	M16 (M12)	17,5 (13,5)	30	25	155 (140)	178,5 (157,5)	40	TS_-U 10012-8-4
150	(135)	176 (155)	202 (175)	M16 (M12)	17,5 (13,5)	30	25	155 (140)	178,5 (157,5)	29	TS_-U 10015-8-2
150	(135)	176 (155)	202 (175)	M16 (M12)	17,5 (13,5)	30	25	155 (140)	178,5 (157,5)	35	TS_-U 10015-8-3
150	(135)	176 (155)	202 (175)	M16 (M12)	17,5 (13,5)	30	25	155 (140)	178,5 (157,5)	42	TS_-U 10015-8-4
150	(135)	176 (155)	202 (175)	M16 (M12)	17,5 (13,5)	30	25	155 (140)	178,5 (157,5)	29	TS_-U 10016-8-2
150	(135)	176 (155)	202 (175)	M16 (M12)	17,5 (13,5)	30	25	155 (140)	178,5 (157,5)	36	TS_-U 10016-8-3
150	(135)	176 (155)	202 (175)	M16 (M12)	17,5 (13,5)	30	25	155 (140)	178,5 (157,5)	42	TS_-U 10016-8-4
150	(140)	176 (166)	202 (192)	M16	17,5	30	25	155 (145)	178,5 (168,5)	43	TS_-U 10016-9-2
150	(140)	176 (166)	202 (192)	M16	17,5	30	25	155 (145)	178,5 (168,5)	52	TS_-U 10016-9-3
150	(140)	176 (166)	202 (192)	M16	17,5	30	25	155 (145)	178,5 (168,5)	61	TS_-U 10016-9-4

Key dimensions of the cylindrical nut: N, M, Y are obtained in the tables of page 38 of the catalogue.

SHUTON advises to use the dimensions of the tables, although it is possible to manufacture ball screw with other dimensions. In brackets () second options. Smaller nut diameters than the first option of the table can reduce the rigidity of the assembly between 5 and 10%.

Please consult SHUTON.

ATR, Single Nut

Ball screw reference	Nominal diameter	Lead	Ball diameter	Root diameter	Circuits	Dynamic load capacity	Static load capacity [kN]	Rigidity of ball contact zone	Rigidity of nut, with $F_{ext}:20\%C_a$	Nut length	
										T_{SB}	T_{SL}
TSB Flanged single nut TSL Cylindrical single nut Recirculation S and U	d_0	P_h	D_w	d_2	$i (le)$	$C_a (N)$	$C_{oa} (N)$	$R_{b/t} (N/\mu m)$	$R_{nut} (N/\mu m)$	T_{SB}	T_{SL}
TS_U 10016-9-5	100	16	9,525	92,2	5	195000	647000	3630	3200	130	130
TS_U 10020-9-2	100	20	9,525	92,2	2	91000	243500	1500	1350	89	89
TS_U 10020-9-3	100	20	9,525	92,2	3	126000	379200	2220	2000	109	109
TS_U 10020-9-4	100	20	9,525	92,2	4	160300	510900	2920	2640	129	129
TS_U 10020-9-5	100	20	9,525	92,2	5	194800	646600	3620	3270	149	149
TS_U 10025-9-2	100	25	9,525	92,2	2	90900	243200	1490	1370	98	98
TS_U 10025-9-3	100	25	9,525	92,2	3	125800	378800	2220	2040	123	123
TS_U 10025-9-4	100	25	9,525	92,2	4	160100	510300	2910	2680	148	148
TS_U 10025-9-5	100	25	9,525	92,2	5	194500	645900	3610	3330	173	173
TS_U 10030-9-2	100	30	9,525	92,2	2	90700	242900	1490	1390	107	107
TS_U 10030-9-3	100	30	9,525	92,2	3	125600	378300	2210	2060	137	137
TS_U 10030-9-4	100	30	9,525	92,2	4	160600	513600	2930	2730	167	167
TS_U 10030-9-5	100	30	9,525	92,2	5	194200	645000	3600	3360	197	197
TS_U 10040-9-2	100	40	9,525	92,2	2	90300	242100	1480	1400	125	125
TS_U 10040-9-3	100	40	9,525	92,2	3	125000	377000	2190	2080	165	165
TS_U 10040-9-4	100	40	9,525	92,2	4	159900	511900	2910	2760	205	205
TS_U 10040-9-5	100	40	9,525	92,2	5	194100	646800	3600	3420	245	245
TS_U 10050-9-2	100	50	9,525	92,2	2	90800	245000	1490	1430	143	143
TS_U 10050-9-3	100	50	9,525	92,2	3	125200	379300	2200	2110	193	193
TS_U 10050-9-4	100	50	9,525	92,2	4	159900	513700	2900	2780	243	243
TS_U 10050-9-5	100	50	9,525	92,2	5	193900	648000	3590	3440	293	293

* C_a and C_{oa} : Modified static and dynamic load capacities, calculated according to DIN 69051/4 standard and ISO3408/5. See pages 39 and 43.

** $R_{b/t}$: Rigidity of the balls contact zone for an external force 20% of C_a . See page 46. For different forces, multiply by $\sqrt[3]{F/0,2 C_a}$

*** R_{nu} : Total rigidity of the complete nut. It must be multiplied by the factor f_{ar} , which depends on the manufacturing tolerance. See page 48.

Nut dimensions										Grease quantity TS 'steel ball'	Ball screw reference
$D_{I, std}$	$D_{I, min}$	D_4	D_6	M	D_5	L_7	L_1	L_8	L_9	$Q_{gr, real, TS} (cm^3)$	TSB Flanged single nut TSL Cylindrical single nut Recirculation S and U
150	(140)	176 (166)	202 (192)	M16	17,5	30	25	155 (145)	178,5 (168,5)	70	TS_-U 10016-9-5
150	(140)	176 (166)	202 (192)	M16	17,5	30	25	155 (145)	178,5 (168,5)	43	TS_-U 10020-9-2
150	(140)	176 (166)	202 (192)	M16	17,5	30	25	155 (145)	178,5 (168,5)	53	TS_-U 10020-9-3
150	(140)	176 (166)	202 (192)	M16	17,5	30	25	155 (145)	178,5 (168,5)	64	TS_-U 10020-9-4
150	(140)	176 (166)	202 (192)	M16	17,5	30	25	155 (145)	178,5 (168,5)	75	TS_-U 10020-9-5
150	(140)	176 (166)	202 (192)	M16	17,5	30	25	155 (145)	178,5 (168,5)	44	TS_-U 10025-9-2
150	(140)	176 (166)	202 (192)	M16	17,5	30	25	155 (145)	178,5 (168,5)	57	TS_-U 10025-9-3
150	(140)	176 (166)	202 (192)	M16	17,5	30	25	155 (145)	178,5 (168,5)	69	TS_-U 10025-9-4
150	(140)	176 (166)	202 (192)	M16	17,5	30	25	155 (145)	178,5 (168,5)	82	TS_-U 10025-9-5
150	(140)	176 (166)	202 (192)	M16	17,5	30	25	155 (145)	178,5 (168,5)	46	TS_-U 10030-9-2
150	(140)	176 (166)	202 (192)	M16	17,5	30	25	155 (145)	178,5 (168,5)	61	TS_-U 10030-9-3
150	(140)	176 (166)	202 (192)	M16	17,5	30	25	155 (145)	178,5 (168,5)	75	TS_-U 10030-9-4
150	(140)	176 (166)	202 (192)	M16	17,5	30	25	155 (145)	178,5 (168,5)	91	TS_-U 10030-9-5
150	(140)	176 (166)	202 (192)	M16	17,5	30	25	155 (145)	178,5 (168,5)	51	TS_-U 10040-9-2
150	(140)	176 (166)	202 (192)	M16	17,5	30	25	155 (145)	178,5 (168,5)	70	TS_-U 10040-9-3
150	(140)	176 (166)	202 (192)	M16	17,5	30	25	155 (145)	178,5 (168,5)	89	TS_-U 10040-9-4
150	(140)	176 (166)	202 (192)	M16	17,5	30	25	155 (145)	178,5 (168,5)	109	TS_-U 10040-9-5
150	(140)	176 (166)	202 (192)	M16	17,5	30	25	155 (145)	178,5 (168,5)	57	TS_-U 10050-9-2
150	(140)	176 (166)	202 (192)	M16	17,5	30	25	155 (145)	178,5 (168,5)	81	TS_-U 10050-9-3
150	(140)	176 (166)	202 (192)	M16	17,5	30	25	155 (145)	178,5 (168,5)	104	TS_-U 10050-9-4
150	(140)	176 (166)	202 (192)	M16	17,5	30	25	155 (145)	178,5 (168,5)	128	TS_-U 10050-9-5

Key dimensions of the cylindrical nut: N, M, Y are obtained in the tables of page 38 of the catalogue.

SHUTON advises to use the dimensions of the tables, although it is possible to manufacture ball screw with other dimensions. In brackets () second options. Smaller nut diameters than the first option of the table can reduce the rigidity of the assembly between 5 and 10%.

Please consult SHUTON.

SHUTON

location and contacts

SHUTON

Pol. Ind. Goian · C/ Subinoa, 5
01170 Legutiano (Álava) - SPAIN

P.O. box 654
01080 Vitoria-Gasteiz - SPAIN

Phone: +34 945 465 629
Fax: +34 945 465 610

Departments contacts

General Information	shuton@shuton.com
Commercial Department	sales@shuton.com

www.shuton.com

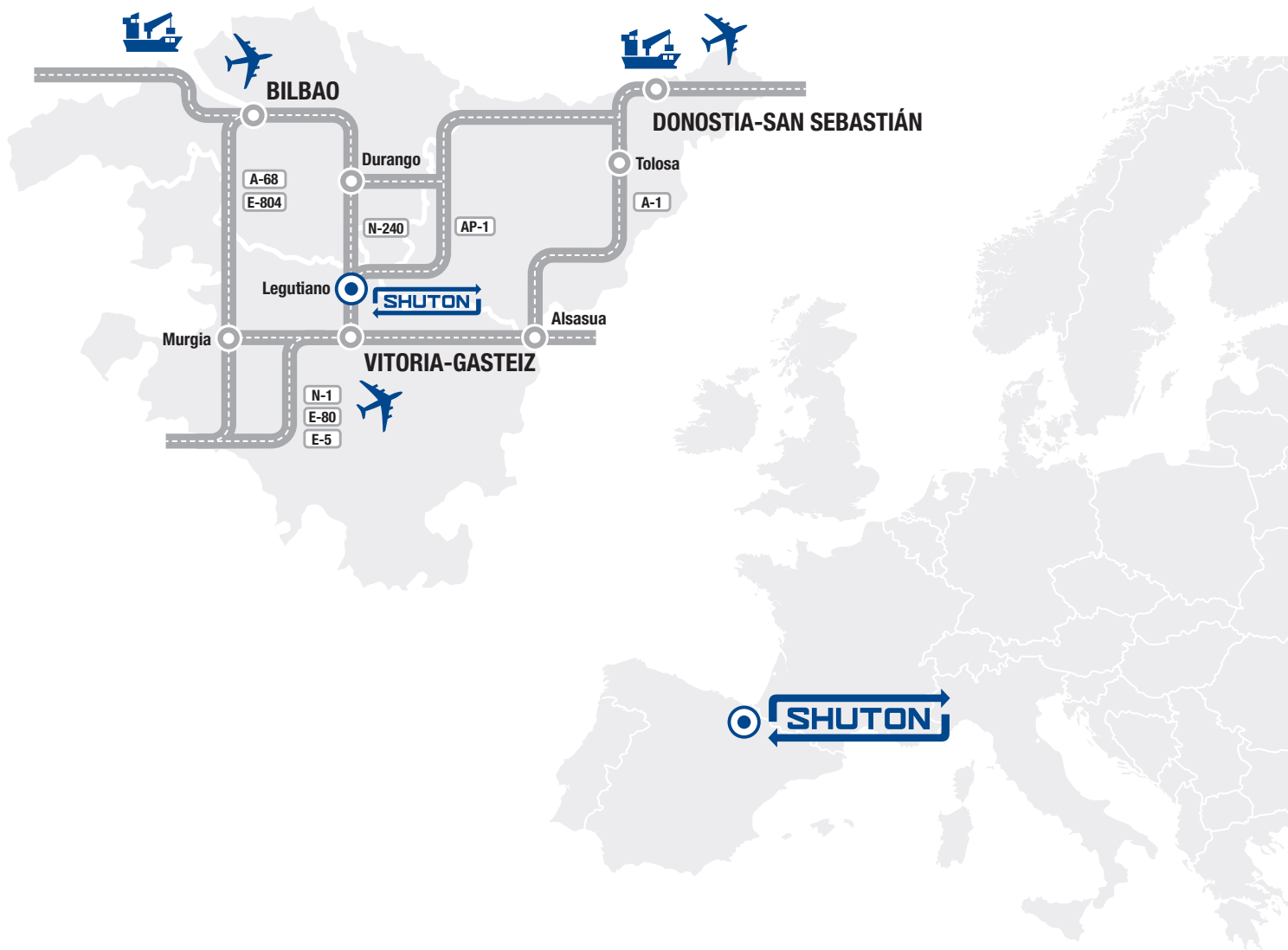

SHUTON

Pol. Ind. Goian · C/ Subinoa, 5
01170 Legutiano (Álava) - SPAIN

P.O. box 654
01080 Vitoria-Gasteiz - SPAIN

Phone: +34 945 465 629
Fax: +34 945 465 610

shuton@shuton.com
www.shuton.com



NADELLA / nadella.com

DURBAL / durbal.de

CHIAVETTE UNIFICATE / chiavette.com

IPIRANGA / ipirangahusillos.com

SHUTON / shuton.com