

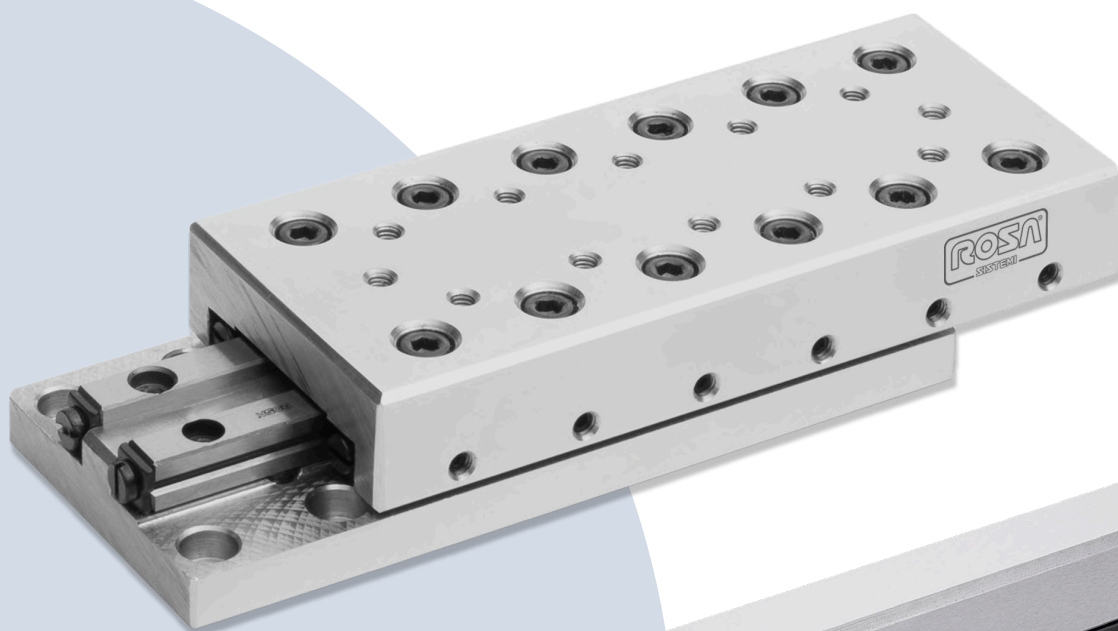

ROLLON[®]
BY TIMKEN

Linear bearings and precision tables



Latest version:

On our website you will always find the actual version of our catalogs.

Disclaimer

The information in this document has been prepared with the utmost care and checked for accuracy. Nevertheless, no liability can be accepted for incorrect or incomplete information. The information and technical data are subject to change without notice.

Table of contents

Introduction.	2
Application by sector	3
Technical characteristics.	4
Mounting recommendations	7
Applications of rails of different length with protruding cages.	10
Inspection tables.	12
Calculation example	14
Linear guideway GR with cross rollers/balls.	17
Linear guideway NG with cross rollers	25
Linear guideway M/V with antifriction material	29
Linear guideway RM/RV with needle rollers.	33
Needle rollers rails RM/RVA	45
Table arrangements	49
Double raceway rails GRD	51
Recirculating linear unit RK	57
Special products.	61
Frictionless table TR (steel and cast iron)	63
Frictionless table TRL (light alloy).	73
Frictionless table TRKD	83
Precision table TV	87

ROLLON®

BY TIMKEN



Rollon: Motion Technology for All Types of Automation

Founded in 1975, for over 45 years Rollon has specialized in the production and development of linear motion systems. Since 2018, Rollon has been a part of The Timken Company, representing the linear motion unit within the Industrial Motion division of Timken. Rollon's solutions are globally adopted in industrial automation, aerospace, medical equipment, material handling, and other sectors where product performance, efficiency and reliability are essential. With the acquisition by The Timken Company of **Nadella, Chiavette Unificate, Durbal, Shuton-Ipiranga, and Rosa Sistemi**, Rollon is now able to offer its customers an even more comprehensive product range – from **linear components, actuators and systems to ball screws, and rotational units.**

Four Decades of Pioneering Achievements in Cutting-Edge Linear Motion Technology: Rosa Sistemi

With over four decades of dedicated work in the field of prismatic rails, rollers, ball recirculating guideways, linear tables, and customized linear systems, Rosa Sistemi has achieved remarkable milestones in cutting-edge linear motion technology. Their contributions to the Rollon linear motion division are truly remarkable. Within their product portfolio, they offer cutting-edge technical solutions tailored to the specific requirements of various demanding industries, including machine tools, aerospace, metrology, medical, electronics, gold machinery, and eyewear. At the heart of Rosa Sistemi's success is a team of highly skilled professionals who play a pivotal role in delivering innovative technical solutions and staying ahead of market demands.

Application by sector

Machine tools in general, particularly

- Centerless grinders
- Bore grinders
- External grinders
- Bearing grinders
- Boring machines
- Milling machines
- Tool sharpening machines

General machinery

- Material forming machines
- Electrical discharge machines
- Welding machines
- Assembly machines
- Manipulators
- Robots
- Optical, precision and electronics industry
- Instruments
- Industrial movie and photography machines
- Measuring systems

Machines for

- Shoe industry
- Optical industry
- Chamfering of lens
- Rubber and tire industry
- Marble and glass industry
- Wood working industry
- Textyle industry
- Gold industry
- Precious stone industry
- Clock working industry
- Ultrasound equipment

Medical industry

- Cat scanners
- Orthopantomographs
- Blood processing equipment
- Optometry equipment

Specialty applications are realized at research centers, chemical laboratories, etc. Our products are used in both private and industrial sector where precise and sensitive movements are required.

Technical characteristics

The rails are made of special alloyed steel and through-hardened to a hardness value of 60 ± 2 HRC. The precision relative to the parallelism variation between the raceways and the reference surface are dependent upon the quality selected (10 micron/1600 millimeters for the "standard" quality, 5 micron/1600 millimeters for the "selected" quality).

It is important to state that all the elements are individually checked during all manufacturing phases before the final inspection. Also, a non-destructive check is performed to assure the absence of internal cracks which may have been generated during heat treating. Such micro-cracks could drastically affect both the precision and the life of the rails.

The advantages obtained by employing rolling systems can be summarized as follows:

- Very sensitive movement (friction coefficient of 0.003)
- Lack of start-up frictional losses (stick-slip)
- Minimum wear
- High load carrying capacity
- Maximized precision
- Availability in stock of all models included in the catalogue

In our production program we have a full range of standardized cross roller tables with lengths ranging from 25 to 1010 mm and widths of 30 to 145 mm; with load ratings from 250 N to 48100 N. The structural members of the tables are made of cast iron (G25), naturally aged, or of steel. A range of anticorrosive tables is also available; their light mass makes it possible to reduce inertial forces.

Manufacturing tolerances

1. Standard quality
2. Selected quality

The rails are through-hardened to 60 ± 2 HRC. The material is alloy steel (DIN 1.2842). Each rail is accurately checked during all the manufacturing phases and it is subjected to a final inspection where the geometry, hardness, surface texture of raceways and adjacent surfaces are thoroughly checked.

Hardness

The rail hardness is of major importance since its variation has a direct influence on the life expectancy of the system. It is important to know that the best working conditions ($F_d = 1$) corresponds to a hardness value of 58 HRC minimum. For hardness lower than 58 HRC, the theoretical load rating should be multiplied by the corresponding hardness factor. Therefore, if a rail with a hardness of 55 HRC and theoretical load rating of 3000 N is used, its load rating will be $C = 3000 \times F_d$ which corresponds to 3000×0.78 thus 2340 N.

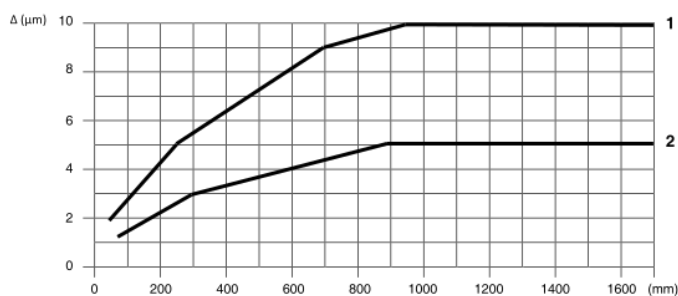

HRC	F_d
20	0.10
30	0.25
40	0.34
45	0.42
50	0.53
55	0.78
57	0.90
58	1.00

Temperature

The temperature also has a great influence on the system life. For temperatures above 80°C the factor Ft should be introduced. The table shows the most common factors if the theoretical load rating of a recirculating ball unit RK 6100 is 715 N such a rating will be reduced to 536,25 N (715 x 0.75) if the temperature rises to 250°C. Permissible operating temperatures is between -40°C and +80°C.

TrC°	Ft
300	0.60
250	0.75
120	0.90
80	1.00

Acceleration

If all the conditions of the system have been verified, values up to 50 m/sec² are allowed.

Speed

Linear systems utilizing GR type rails could be used for speed up to 50 m/min. If higher speeds are sought, our engineering office should be consulted

Sealing and protection

It is absolutely necessary that the linear system is protected from impurities of either solid or liquid nature.

Multi-piece ways

For systems requiring longer than standard catalogue rails, multipiece ways can be provided. To accomplish this, the individual rails are head-ground and ground simultaneously to the required length. By doing so, there will be no difference in precision and smoothness. In case of shipping of multi- piece system, the individual rails will be numbered to allow proper mounting.

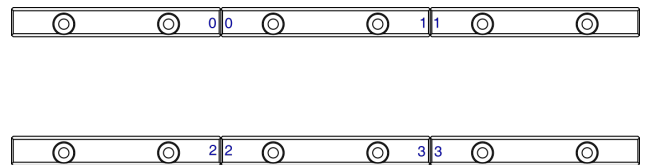

Lubrication

The rolling systems are usually lubricated with a thin oil film applied during assembly. This lubrication method allows the better utilization of the precision and smoothness characteristics of such an arrangement. However, should the application dictate it, oil-drip, oil-mist can be used. (Type CLP or LP with viscosity from ISO V6 15 to 100 like DIN 51519)

Preload

Usually the preload is applied with set screws placed in correspondence of the mounting screws by using appropriate dynamometric spanners. A system could also be preloaded by means of a tapered gib, a wedge of cylinder, though all of these methods are more complex and require a more accurate execution of the supporting structure. Such accuracy may not be achievable or even wanted by the user. The preload setting is usually dictated by the application and can vary between 2% and 20% of the dynamic load rating C of the system examined.

Life

We have already examined two of the factors which may affect life of a rolling system (temperature and hardness). In addition, we like to mention others which are also important.

1. Manufacturing tolerances of the supporting surfaces non-respondent to the minimum requirements;
2. Mounting not according to our recommendations;
3. Presence of particles or impurities between the rolling elements;
4. The system should not be subjected to its maximum allowable load until after a break-in period to allow proper adjustment of the system itself.

In these conditions are respected the life of a system can be calculated according to the following formula:

$$L = FD \times \left(\frac{C}{P}\right)^a \times 10^5 \text{ (m)}$$

- L = Basic rated life (m)
FD = Reliability factor (see table)
C = Dynamic load rating (N)
P = Dynamic load (N)
a = Life exponent (10/3 for rollers, 3 for balls)
Lh = Basic rated life (hours)
Nc = Frequency of reciprocating motion in 1 minute
H = Stroke length (mm)

Example: Given - roller 9 mm

$$C = 1300 \text{ N}$$

$$P = 200 \text{ N}$$

Rail hardness = HRC 58

Temperature = 100°C

Reliability 90% FD = 1

$$L = 1 \times \left(\frac{1300}{200}\right)^{10/3} \times 10^5 = 513 \text{ in } 10^5 \text{ (m)}$$

$$Lh = \frac{8.33}{H \times Nc} \times L = \frac{8.33 \times 513 \times 10^5}{400 \times 30} = 3610 \text{ hours}$$

%	FD
90	1.00
95	0.62
96	0.53
97	0.44
98	0.33
99	0.21

Mounting recommendations

The figure on the right side represents the two components which are usually equipped with way systems with either rollers, balls or needles. The structure onto which the rails have been mounted must be sturdy enough so as to prevent rails from taking particular positions, when stressed by the preload, which may jeopardize the ideal geometry between rollers and raceways:

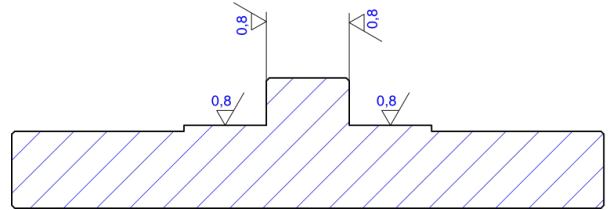
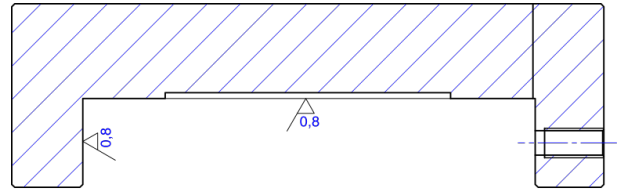

For a properly executed mounting, the following condition should be verified:

1. The supporting surfaces should be ground or, in the worst case, milled, paying particular attention to the process;
2. The planarity and parallelism of the system are directly affected by the precision of the surfaces indicated to be ground. The deviation allowance for such surfaces should be within the values indicated on the graph;
3. The included angle between the two adjacent surfaces should be 90°;
4. The holes for the retention screws should be carefully deburred to guarantee the surface quality of the supporting face.

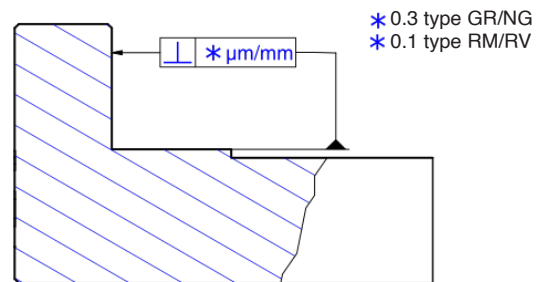

It should be noticed that all rails have threaded holes. This allows for two different mounting methods.

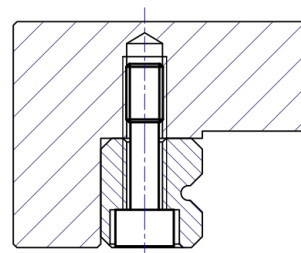
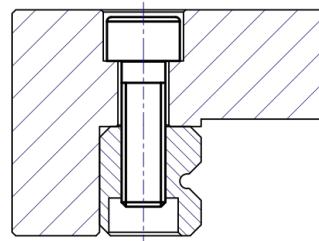

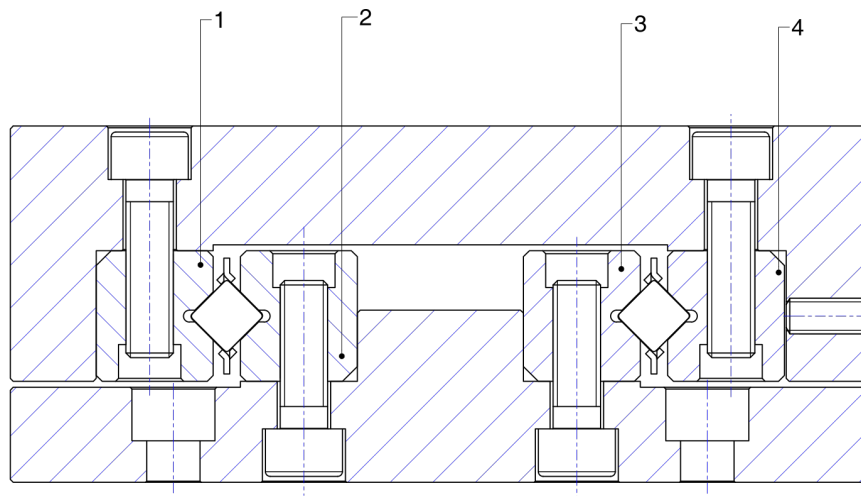

Mounting of rails

Independently from any assembly method, we recommended to follow these steps:

1. Assembly of rails 2 and 3, which should be carefully pressed against the supporting surfaces before tightening of the screws;
2. Checking of the planarity, parallelism of the rails installed;
3. Installation of the rail 1, following the same steps as for rails 2 and 3;
4. Installation of the rail 4, without tightening the retaining screws;
5. Installation of the relative cages;
6. Installation of end pieces and/or wipers;
7. Slide the moving portion of the system to the end of the travel/stroke to allow the centering of the cages;
8. Tighten the preloading screws sufficiently to eliminate the clearance. The preloading value should be selected according to the application requirement (rail type, rigidity, etc.). Such a value may vary between 2% and 20% of the rated dynamic capacity C . In all cases the smoothness of the system must be preserved;
9. Tighten the retaining screws of rail 4;
- 10. To ensure a proper mounting of the rail, the marking should be visible at all times;**
11. For a mounting as shown along the side, the height A and $A1$ can be matched, at extra cost, to a maximum variation of ± 0.01 mm;
12. After the assembly, make sure that the limit switch trips before the cages hit the screws or the end pieces.

Note: During the preloading phase the cage must always be behind the preloading screw that is adjusted.

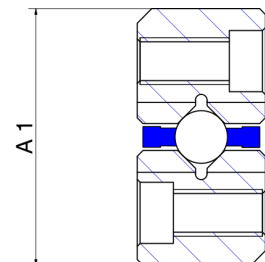
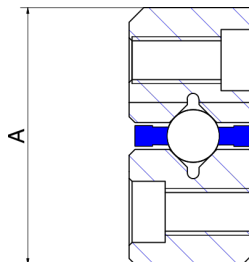

Determination of cage length

- t = Roller cage pitch
- L = Rail length
- H = Stroke
- Lg = Cage length
- NR = Number of rollers

Assuming to choose the rail type GR9 400 with a stroke length H = 250 mm.

The cage length is determined by the following equation:

$$L_g = L - \frac{H}{2}$$

Thus, $L_g = 400 - (250/2) = 275$ mm

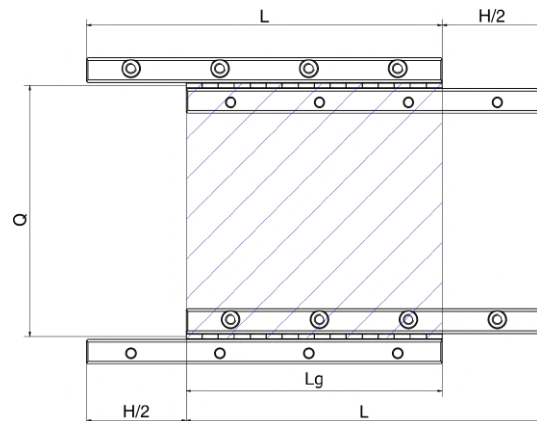

Note: The selection of a specific rail length, as a function of given stroke, should satisfy the following requirements:

1. If the rail length will be up to 400 mm, all strokes between 1 mm and 2/3 of the rail length will be possible;
2. If the rail length will be more than 400 mm, all strokes between 1 mm and the length of the rail will be possible. Based on the above, in a system riding on four rails of equal length (500 mm) the moving portion could overhand 1/2 of its length (condition limit).

Determination of the number of rolling elements and the load rating of cage

From the previous example, $L_g = 275$ mm

Rail type GR9

Roller diameter 9 mm

Examining the table on page 20 to obtain the value of the pitch relative to the cage/roller in exam.

$t = 18$ mm thus, the number of roller will be $NR = L_g/t = 15$

The number of supporting rollers for a cross roller cage will be $NR/2$.

However, the usual assembly requires two rail systems, thus the total capacity will be a function of NR or the number of rollers in one cage, being $C = 1300$ N the load carrying capacity of a roller.

(see dimension table on page 20)

The system load rating will be: $C = C \times NR = 1300 \times 15 = 19500$ N.

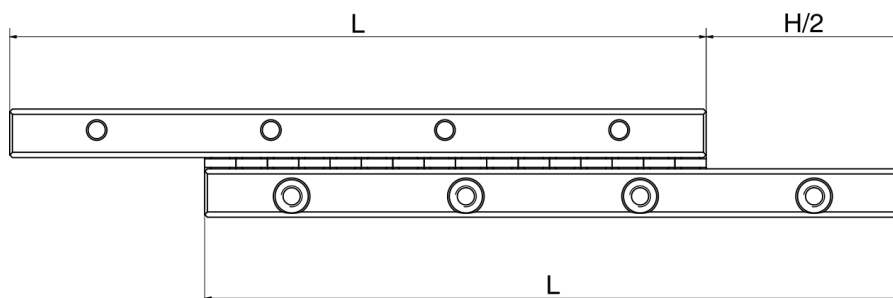

Applications of rails of different length with protruding cages

If, for example, we intend to build a small carrier (200 mm long) which rides on a structure 800 mm long for a stroke of 600 mm, assuming the loads to be of limited magnitude, we could select the following material:

- 2 rails - GR9 800
- 2 rails - GR9 200 with chamfers
- 2 cages - AA9 with 27 rollers
- 4 end pieces - GC9

In this case the selection was based on the longer rail, thus:

$$L_g = L - H/2 = 800 - 300 = 500 \text{ mm}$$

$$NR = L_g/t = 500/18 = 27.7 \text{ (thus 27 rollers)}$$

We will need also the chamfering of the rails GR9 200 to maintain the smoothness of travel of the table. The load carrying capacity will be based on the number of rollers within the two rails:

$$NR = L_1/t = 200/18 = 11.1 \text{ (thus 11 rollers)}$$

Since the load rating is 1300 N/roller, the load rating will be:

$$C = 11 \times 1300 = 14300 \text{ N}$$

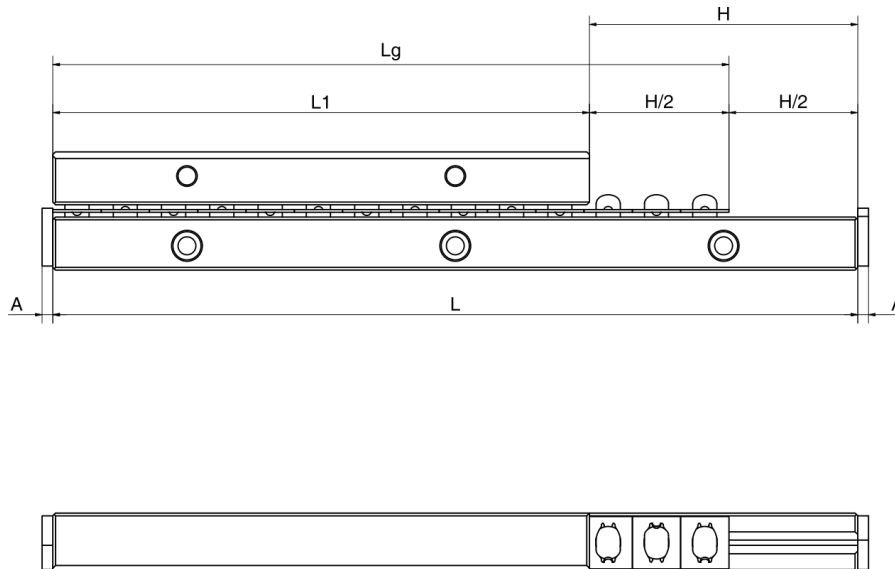

Inspection table example



Via Quasimodo 22/24
20025 LEGNANO MI
- ITALY -

TAB.801-1 Rev. 2

INSPECTION TABLE

Date: _____

Rail type: GR_____

Resp.: _____

Order Number: _____

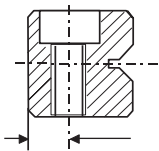

Max error (specification)	$\pm 0.2 \text{ mm}$
Error (measured)	

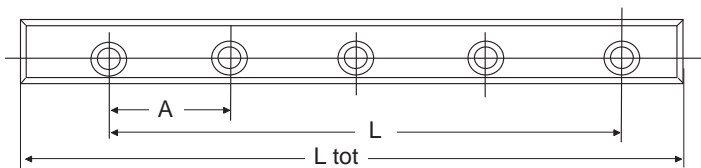

	GR1	GR2	GR3	GR6	GR9	GR12
A	10	15	25	50	100	100
Max error (specification)	$\pm 0.3 \text{ mm}$					
Error (measured)						
L	$L \leq 350 \text{ mm}$			$L > 350 \text{ mm}$		
Max error (specification)	$\pm 0.3 \text{ mm}$			$\pm 0.8 \text{ ‰ L}$		
Error (measured)						
Max error (specification) on rail's length (Ltot)	$L_{tot} \leq 300 \text{ mm } \pm 0.3 \text{ mm}$			$L_{tot} > 300 \text{ mm } \pm 1\text{‰ } L_{tot}$		
Error (measured)						

Roughness (specification) referred to raceways	0.300 RA
Roughness (measured)	
Hardness (specification)	$60 \pm 2 \text{ HRC}$
Hardness (measured)	

Inspection table example



Via Quasimodo 22/24
20025 LEGNANO MI
- ITALY -

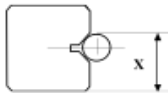

	GR	GR (QS)
Max error (specification) X	± 0.005 mm	± 0.0025 mm
Error (measured)		

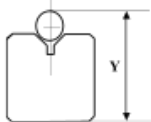

Max error (specification) Y	0 / -0.1 mm
Error (measured)	0 / -0.1 mm

Parallelism variation vs length

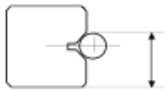

ERROR SPECIFICATION

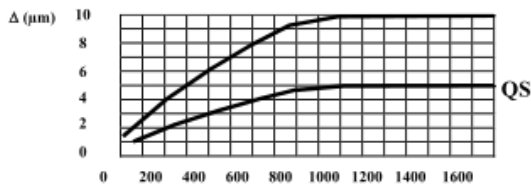

ERROR MEASURED

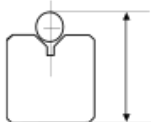
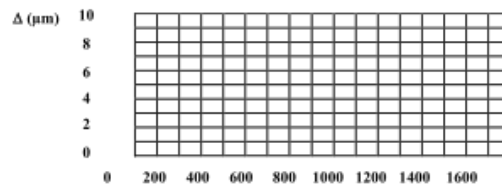

ERROR SPECIFICATION

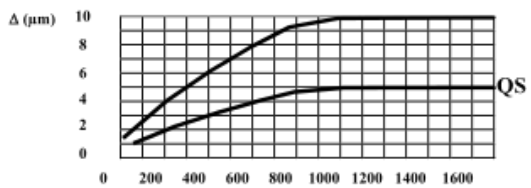

ERROR MEASURED

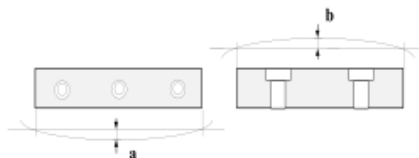
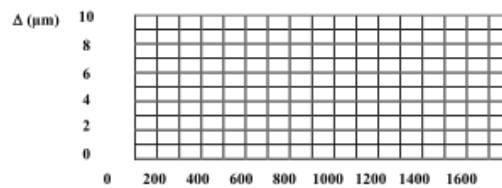

	SPECIFICATION	MEASURED
Arrows (a)		
Arrows (b)		

(mm)

Calculation example

Due to elastic deformations of a linear system and to the lack of uniformity in the distribution of the unit loads, we resorted to theoretic safety factors (CTS) according to which the close contact between the mobile part and raceways is given by the following quantities:

CTS crossrollers	2
CTS balls	4
CTS needles	1

Example 1

Calculation example and load check:

- Rails = GR9 300
- Stroke = 180 mm
- Cages = AA9 with 11 rollers
- Load (P) = 6000 N
- Lg = 210 mm
- Preload = 10%

$$\text{Roller load} = \frac{6000}{11} = 545.5 \text{ N}$$

$$\text{Load due to mobile portion NR} = 80/11 = 7.3 \text{ N}$$

It is also necessary to take the preload into account.

That is: 10% of 545.5 N = 54.6 N

The sum of the forces acting on the table (preload, weight, external load, etc.) must be smaller than the capacity C which in this case is 1300 N.

Therefore:

$$545.5 + 7.3 + 54.6 = 607.4 \text{ N} \quad 607.4 \text{ N} < 1300 \text{ N}$$

Thus our selection is verified positively.

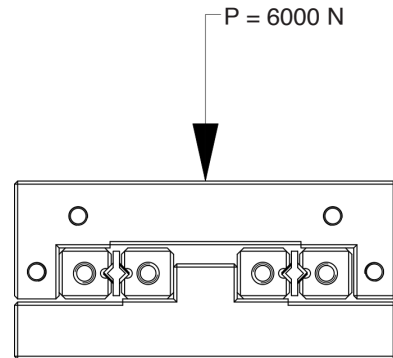

Example 2

Loading condition as indicated in the pictures below. Rails, cages and stroke characteristics as in table TR6 310, therefore:

- NR = 16
- NRP (number of supporting rollers) = 16:2 = 8
- Preload = 8% (P3)
- Upper table weight = 45 N (P2)
- External load = 200 N (P)
- b = 300 mm
- Lg = 180 mm
- CTS = 2

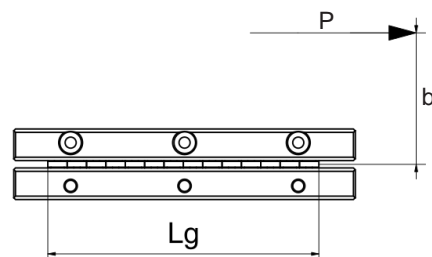
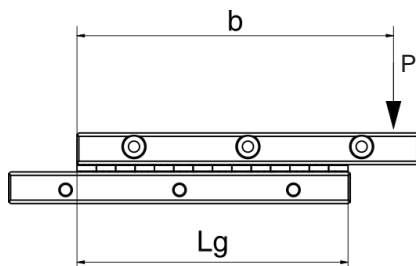

This calculation is valid for both cases 12a and 12b:

$$P1 = \frac{P \times b}{C \times CTS} = \frac{200 \times 300}{180 \times 2} = 166.7 \text{ N}$$

$$P2 = 45 \text{ N} / 16 = 2.8 \text{ N}$$

$$P3 = 8\% \times 166.7 \text{ N} = 13.3 \text{ N}$$

$$\Sigma P = P1 + P2 + P3 = 166.7 + 2.8 + 13.3 = 182.8 \text{ N} < 530 \text{ N}$$

where 530 N is the load rating for a roller diameter of 6 mm (table on page 20).

This calculation is valid for the roller at the two extremities of the cage, thus it represents the worst condition. In addition, if only the roller of the extremities would be under load, both rails and structure would deform permanently.

Therefore, it is safe to assume that the load distribution is similar to the one depicted on the right side.

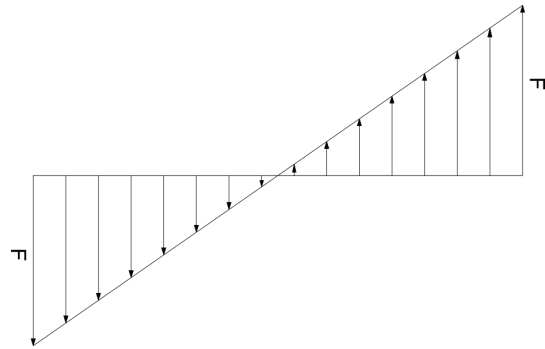

Example 3

The rails, cages and stroke characteristics as in table TR3 155, therefore:

- b = 120 mm
- Q = 28 mm
- NR = 21
- NRP = 21/2 = 10.5 -> we will consider 10
- Preload = 10% (P3)
- Upper table weight = 7 N (P2)
- C = 130 N/Roller
- P = 2

$$P1 = \frac{P \times b}{Q \times NRP} = \frac{160 \times 120}{28 \times 10} = 68.6 \text{ N}$$

$$P2 = 0.33 \text{ N}$$

$$P3 = 10\% \times 68.6 = 6.86 \text{ N}$$

$$\Sigma P = P1 + P2 + P3 = 75.8 \text{ N} < 130 \text{ N}$$

where 130 N is the load rating for a roller diameter of 3 mm (table on page 20)

Therefore our system loading checks out.

Note: For applications not shown, please refer to our engineering office.

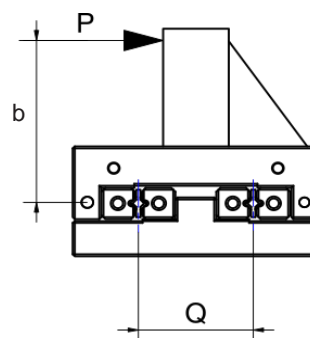
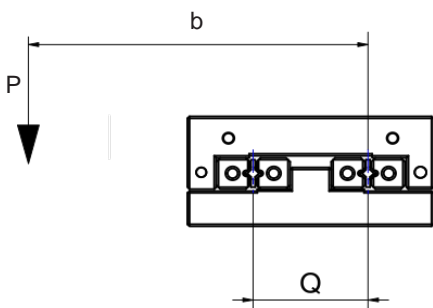

Linear guideway GR with cross rollers/balls

GR linear system bearings could utilize either cross rollers or balls as rolling elements. The two will differ substantially in load ratings. The ratio is approximately 10 to 1 in favor of rollers, depending upon the dimension under consideration.

Balls are more advantageous in case of presence of impurities and/or misalignment as it happens when the structure, to which rails are anchored, is not sturdy enough to support them and rails are not therefore placed in their correct position.

Such systems offer good load rating with respect to the cross section, length and relative stroke. They utilize different cages and end pieces depending upon the application.



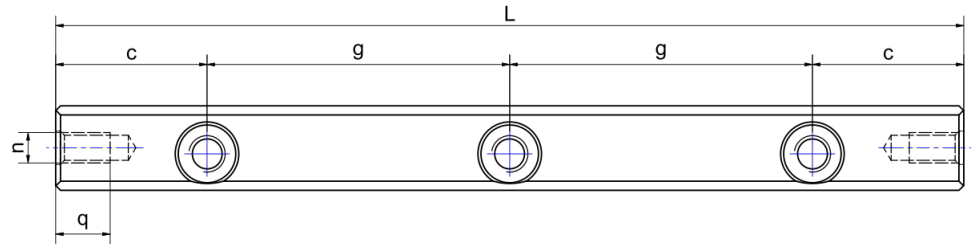
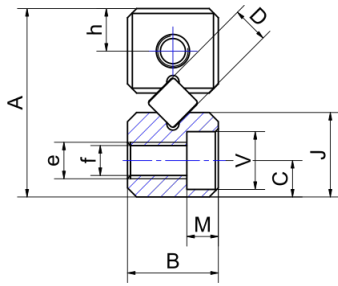

Type	Size	L in mm	Weight in g	g	c	D	A 0 -0.3	B	J	C	e	f	V	M	h	q	n	Options	Accessories
GR	1	020	2	10	5	1.5	8.5	4	3.9	1.8	M2	1.65	3	1.4	1.9	2.5	M1.7	01 02 13	Cage type • PR1 • PS1 End pieces • GA1
		030	3																
		040	4																
		050	5																
		060	6																
		070	7																
		080	8																
		090	9																
		100	10																
		120	12																
140	14																		
GR	2	030	6	15	7.5	2	12	6	5.5	2.5	M3	2.5	4.3	2	2.7	3.5	M2.5	01 02 13	Cage type • PR2 • PS2 • AA2 End pieces • GA2 • GB2
		045	9																
		060	12																
		075	15																
		090	18																
		105	22																
		120	25																
		135	28																
		150	31																
		180	37																
210	44																		
GR	3	050	23	25	12.5	3	18	8	8.2	3.5	M4	3.3	6	3.2	4	5.5	M3	01 02 13	Cage type • PR3 • PS3 • AA3 End pieces • GA3 • GB3 • GC3 • GC3.08 Fixing screw • VM3
		075	34																
		100	45																
		125	56																
		150	67																
		175	78																
		200	89																
		225	100																
		250	111																
		275	122																
300	133																		

Option description

01 - inlets rounded | 02 - QS | 08 - wiper | 13 - selected A = +/- 0.01 mm

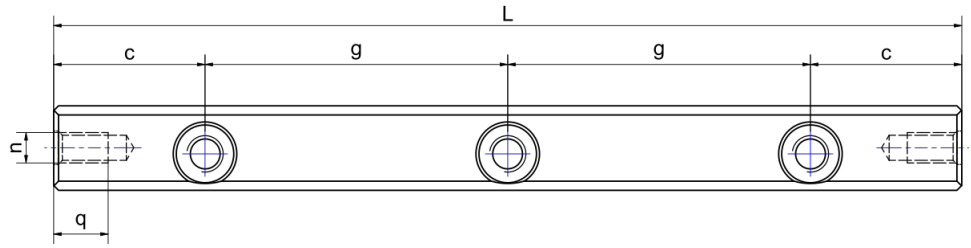
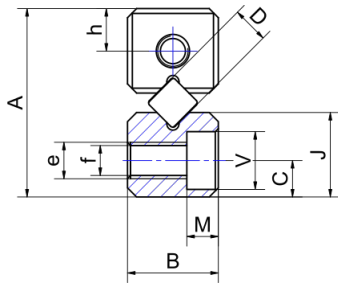

Type	Size	L in mm	Weight in g	g	c	D	A 0 -0.3	B	J	C	e	f	V	M	h	q	n	Options	Accessories
GR	6	100	145	50	25	6	31	15	13.9	6	M6	5.2	9.5	5.2	7	9	M5	01 02 13	Cage type <ul style="list-style-type: none"> PR6 PS6 AA6 AL6 End pieces <ul style="list-style-type: none"> GA6 GB6 GC6 GC6.08 Fixing screw <ul style="list-style-type: none"> VM5
		150	220																
		200	325																
		250	370																
		300	445																
		350	520																
		400	595																
		450	670																
		500	745																
		550	815																
600	885																		
GR	9	200	630	100	50	9	44	22	19.7	9	M8	6.8	10.5	6.2	10	9	M6	01 02 13	Cage type <ul style="list-style-type: none"> PR9 PS9 AA9 AL9 End pieces <ul style="list-style-type: none"> GA9 GB9 GC9 GC9.08 Fixing screw <ul style="list-style-type: none"> VM6
		300	945																
		400	1260																
		500	1575																
		600	1890																
		700	2205																
		800	2520																
		900	2835																
		1000	3150																
		1100	3465																
		1200	3780																
GR	12	200	1040	100	50	12	58	28	25.9	12	M10	8.5	13.5	8.2	12.9	12	M8	01 02 13	Cage type <ul style="list-style-type: none"> PR12 PS12 AA12 End pieces <ul style="list-style-type: none"> GA12 GB12 GC12 GC12.08 Fixing screw <ul style="list-style-type: none"> VM8
		300	1565																
		400	2090																
		500	2615																
		600	3140																
		700	3665																
		800	4190																
		900	4715																
		1000	5240																
		1100	5765																
1200	6290																		

Option description

01 - inlets rounded | 02 - QS | 08 - wiper | 13 - selected A = +/- 0.01 mm

Cages

Type AA

Captive cross roller cage for **GR 2 ÷ GR 12** horizontal application. Material: sheet metal.

GR 2 ÷ GR 12 t pitch

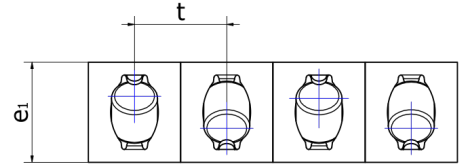
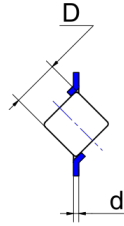

Type PS

Captive ball cage for **GR 1 ÷ GR 12** rails for horizontal and vertical applications. Material: polyamide.

GR 1 ÷ GR 12 t₂ pitch

PS 6 ÷ PS 12 reinforced with steel.

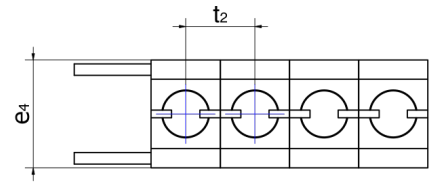
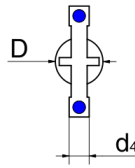

Type PR

Captive cross roller cage for **GR 1 ÷ GR 12** rails for horizontal and vertical applications. Material: polyamide.

GR 1 ÷ GR 3 t pitch

GR 6 t₃ pitch

GR 9 t₁ pitch

GR 12 t₃ pitch

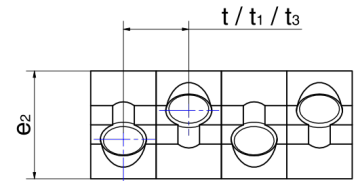
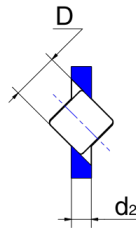

Type AL

Captive cross roller cage for **GR 6 ÷ GR 9** rails for horizontal and vertical applications. Material: aluminum.

GR 6 t₁ pitch

GR 9 t₁ pitch

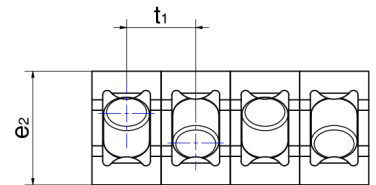
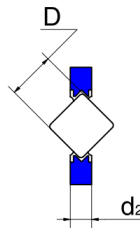

Rail type												C (N)	
	D	t	t ₁	t ₂	t ₃	d	d ₂	d ₄	e ₁	e ₂	e ₄	C roller	C ball
GR 1	1.5	3	-	2.2	-	0.5	0.5	0.45	-	3.8	3.5	50	9
GR 2	2	4	-	4	-	0.8	0.8	0.75	5.5	5.5	5	85	15
GR 3	3	5	-	4.2	-	0.5	1	1	7	7	7	130	25
GR 6	6	12	9	9	8.5	0.8	2.7	2.5	14	15	14	530	65
GR 9	9	18	14	14	-	1	4	3.2	19.5	20	20	1300	150
GR 12	12	22	18	15.5	16	1.2	4	4	25	25	20	2500	260

End pieces

Type GA

For horizontal applications.

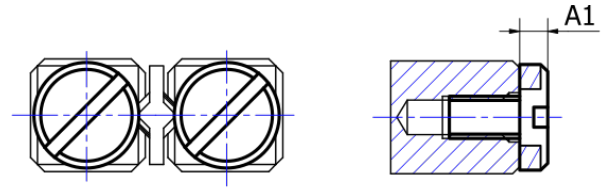

Type GB

For horizontal and vertical applications with high accelerations.
(not available for GR 1 rails)

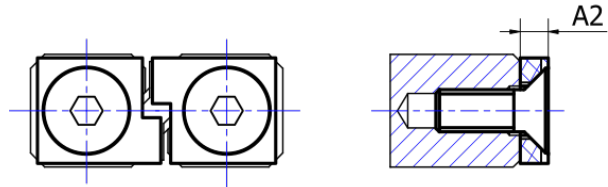

Type GC

For horizontal and vertical applications with or without wipers.
Mounted only on the longer rails.
(not available for GR 1 ÷ GR 2 rails)

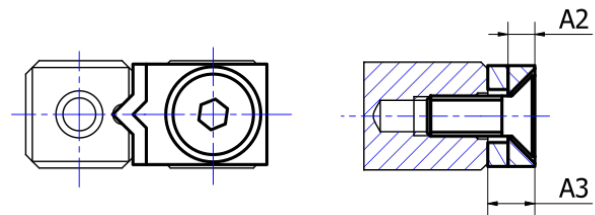

Dimension	GR 1	GR 2	GR 3	GR 6	GR 9	GR 12
A1	1.5	2	2	3	3	3
A2	-	3	2	3	4	5
A3	-	-	3	5	6	8

Mounting screws with modified stem

These screws offer the following advantages:

- Compensation for pitch errors in the supporting structure
- Compensation for pitch variation during heat treating
- Elimination of clearance through lateral screws

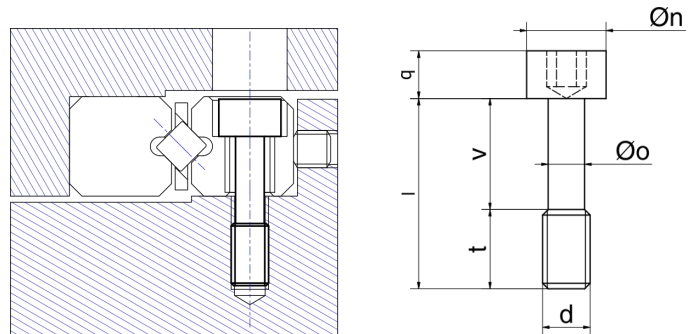

Dimension	GR 3	GR 6	GR 9	GR 12
l	12	20	30	40
Øn	5	8	8.5	11.3
Øo	2.3	3.9	4.6	6.25
d	M3	M5	M6	M8
q	3	5	6	8
v	7	12	18	23
t	5	8	12	17
s	2.5	4	5	6
Code	VM3	VM5	VM6	VM8

Ordering examples

To simplify the ordering, thus the delivery, the following examples should be followed. We assumed, like in most cases, that one table utilizes 4 rails, 2 cages and 8 end pieces. Therefore, the information required should include:

- Number and type of rail
- Number and type of cage
- Number of rolling elements in each cage or cage length or stroke
- Number and type of end pieces
- Type of application (horizontal or vertical)

For horizontal movement (rollers)

System GR3 125
Stroke = 35 mm
4 Rails GR3 125
2 Cages AA3 with 21 rollers
8 End screw GA3

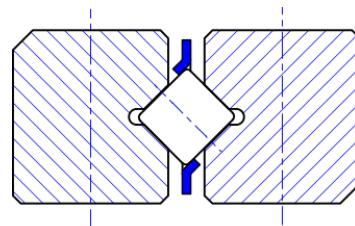

For vertical movement (rollers)

System GR6 300
Stroke = 120 mm
4 Rails GR6 300
2 Cages PR6 with 28 rollers
8 End pieces GB6

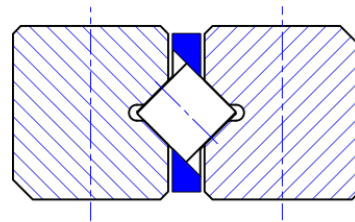

For horizontal and vertical movement (balls) and wipers

System GR9 400
Stroke = 185 mm
Reduced Pitch t_2
4 Rails GR9 400
2 Cages PS9 with 21 balls
4 End pieces with wiper GCT9.08

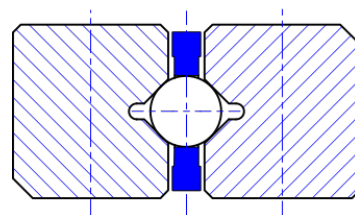

Linear guideway NG with cross rollers

The present evolution of the GR type is passing through the realization of guideways that in spite of their smaller section are performing better features in respect of the carrying capacity and therefore of stiffness. This new kind of guideway named NG has two different sections whose dimensions are stated in the following page.



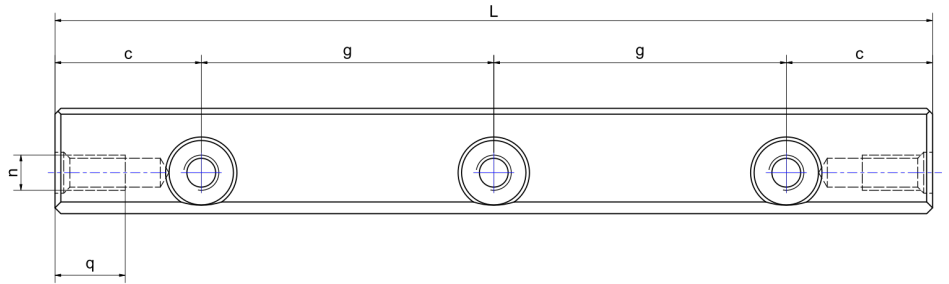
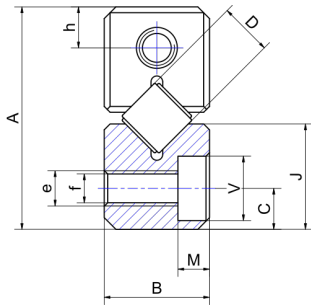

Type	Size	L in mm	Weight in g	g	c	D	A 0 -0.3	B	J	C	e	f	V	M	h	q	n	Options	Accessories
NG	4	050	27	25	12.5	4.5	19	9	9	3.5	M3	2.65	5.5	2.7	3.5	6	M3	01 02 13	Cage type • BN4 End pieces • NB4 • NC4 • NC4.08 Fixing screw • VBN4
		075	41																
		100	55																
		125	69																
		150	83																
		175	97																
		200	111																
		225	125																
		250	139																
		275	153																
		300	167																
NG	6	100	92	25	12.5	6.5	25	12	12	5	M4	3.3	7	3.2	5	6	M3	01 02 13	Cage type • BN6 End pieces • NB6 • NC6 • NC6.08 Fixing screw • VBN6
		150	138																
		200	184																
		250	230																
		300	276																
		350	322																
		400	368																

Option description

01 - inlets rounded | 02 - QS | 08 - wiper | 13 - selected A = +/- 0.01 mm

Cages

With retained rollers; for horizontal and vertical stroke
Material: delrin

Cage type	Rail type	t	D	C (N)
BN 4	NG 4	6.5	4.5	850
BN 6	NG 6	8.5	6.5	1800

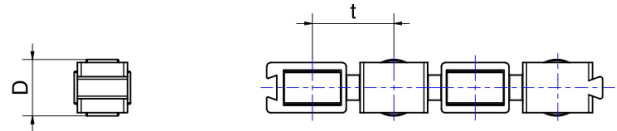

Endpieces

Type NB

for horizontal and vertical application

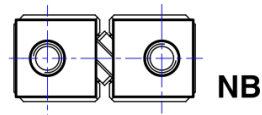

Type NC

for applications with guideways of different length.
They are mounted on the longest guideways.
They can be provided with race-wiper.

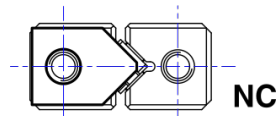

End piece type	Dimension	Rail type NG 4	Rail type NG 6
NB / NC	A1	4	4
NC	A2	5.5	5.5

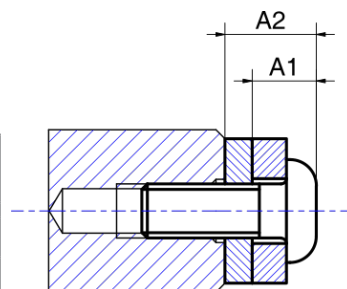

Fixing screws

Dimensions	Rail type NG 4	Rail type NG 6
l	12	16
\varnothing_n	4.5	5.5
\varnothing_o	1.85	2.3
d	M2.5	M3
q	2.5	3
v	7	11
t	5	5
s	2	2.5
Code	VBN 4	VBN 6

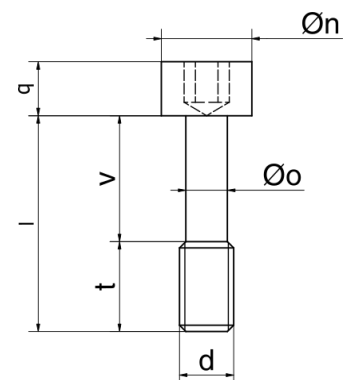



Linear guideway M/V with antifriction material

M/V linear guideways have an antifriction material coating and keep identical characteristics than RVA's models.

As for the dimensions, are the same of the guideways GR but these improving the stiffness of the system.

These guideways are used above all to eliminate any vibration of the system.

Load capacity per cm²: 4500 N (dynamic) ÷ 7500 N (static).

Rail type	Width of bearing surface
M 3	0.3 cm
M 6	0.6 cm
M 9	1.2 cm
M 12	1.6 cm



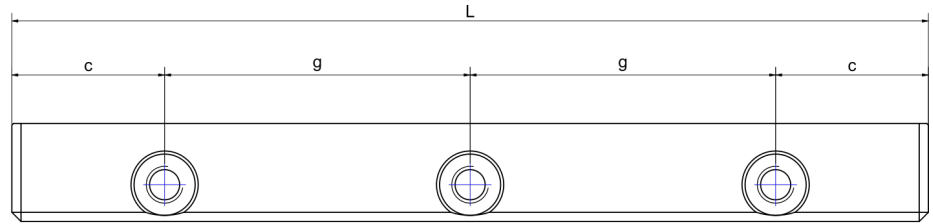
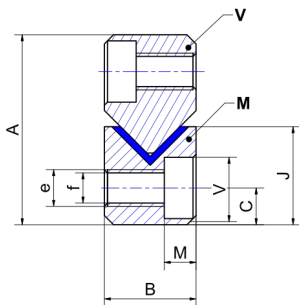

Type	Size	L in mm	Weight in g M rail	Weight in g V rail	g	c	A 0 -0.3	B	J	J ₁	C	e	f	V	M	Options	Accessories
M/V	3	050	19	25	25	12.5	18	8	9	10.8	3.5	M4	3.3	6	3.1	02 03 13	Fixing screw • VM3
		075	30	38													
		100	41	51													
		125	52	64													
		150	63	77													
		175	74	90													
		200	85	103													
		225	96	116													
		250	107	129													
		275	118	142													
		300	130	155													
M/V	6	100	145	175	25	25	31	15	16	19.3	6	M6	5.3	10	5.2	02 03 13	Fixing screw • VM5
		150	218	263													
		200	290	350													
		250	363	438													
		300	435	525													
		350	508	613													
		400	580	700													
		450	653	788													
		500	725	875													

Option description

02 - QS | 03 - lubrication holes and groove | 13 - selected A = +/- 0.01 mm

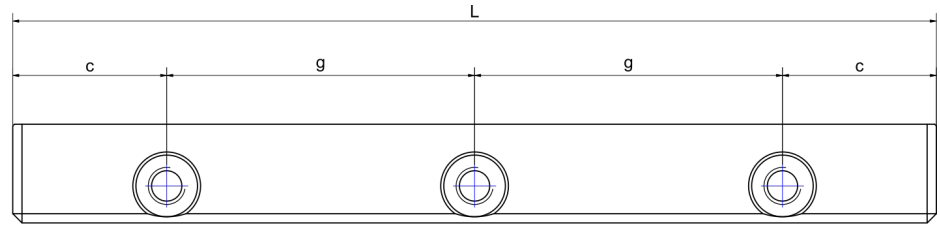
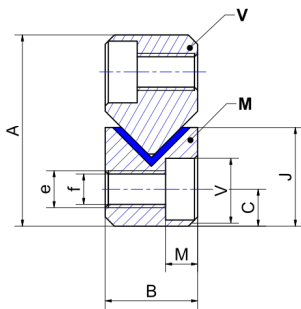

Type	Size	L in mm	Weight in g M rail	Weight in g V rail	g	c	A 0 -0.3	B	J	J ₁	C	e	f	V	M	Options	Accessories
M/V	9	200	640	770	100	50	44	22	24	28	9	M8	6.8	11	6.2	02 03 13	Fixing screw • VM6
		300	955	1156													
		400	1270	1543													
		500	1585	1930													
		600	1900	2316													
		700	2215	2703													
		800	2530	3089													
		900	2845	3476													
		1000	3160	3862													
M/V	12	200	1130	1224	100	50	58	28	33	35.5	12	M10	8.5	15	8.2	02 03 13	Fixing screw • VM8
		300	1690	1836													
		400	2250	2448													
		500	2810	3060													
		600	3370	3672													
		700	3930	4284													
		800	4490	4896													
		900	5050	5508													
		1000	5610	6120													
		1100	6175	6732													
		1200	6740	7244													

Option description

02 - QS | 03 - lubrication holes and groove | 13 - selected A = +/- 0.01 mm

Fixing screws M/V

Dimension	M/V 3	M/V 6	M/V 9	M/V 12
l	12	20	30	40
Øn	5	8	8.5	11.3
Øo	2.3	3.9	4.6	6.25
d	M3	M5	M6	M8
q	3	5	6	8
v	7	12	18	23
t	5	8	12	17
s	2.5	4	5	6
Code	VM3	VM5	VM6	VM8

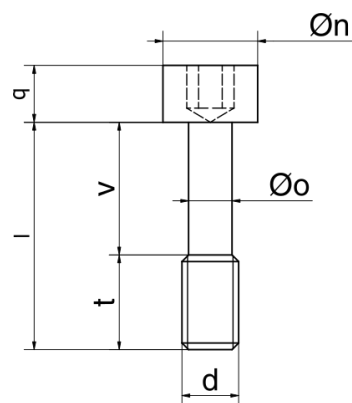

Linear guideway RM/RV with needle rollers

The same calculation criteria used for GR rails is valid for the rails RM/RV. However, the difference with GR type, should be accounted for:

- Higher load ratings
- Higher rigidity
- Better overlapping of the rollers, especially in case of short stroke
- Higher sensibility to mounting errors and impurities



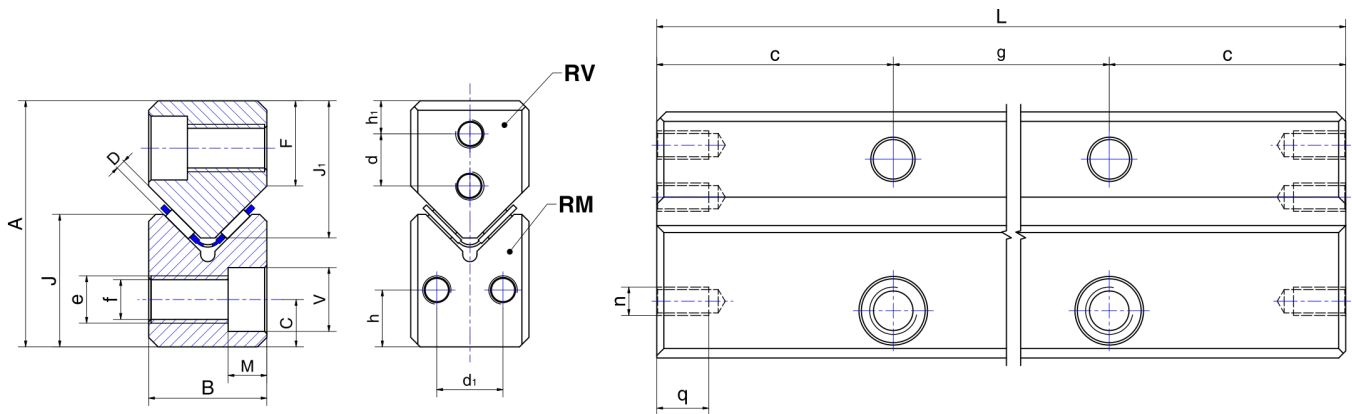

Type	Size	L in mm	Weight in g M rail	Weight in g V rail	g	c	D	A 0 -0.3	B	F	J ₁	J	C	e	f	V	M	n	q	h	h ₁	d	d ₁	Options	Accessories
RM RV	3115	100	161	143	50	25	2	31	15	11	17.5	16	6	M6	5.2	9.5	5.2	M3	7	7.5	4.5	7	7	01 02 13 18	Cage type • HW10 AL • HW10 OT End pieces • GM3115 • GM3115.08 • GV3115 • GV3115.08 Fixing screw • VM5
		150	243	216																					
		200	324	289																					
		250	406	361																					
		300	487	434																					
		350	569	507																					
		400	651	580																					
		450	732	652																					
		500	814	725																					
		550	895	798																					
600	977	871																							
RM RV	92025	200	685	695	100	50	2	44	22	15	24.5	24	9	M8	6.8	10.5	6.2	M4	10	11	6	10	10	01 02 13 18	Cage type • HW15 AL • HW15 OT End pieces • GM92025 • GM92025.08 • GV92025 • GV92025.08 • GFM92025 • GFV92025 Fixing screw • VM6
		300	1020	1030																					
		400	1355	1365																					
		500	1690	1700																					
		600	2025	2035																					
		700	2360	2370																					
		800	2695	2705																					
		900	3030	3040																					
		1000	3365	3375																					
		1100	3700	3710																					
		1200	4035	4045																					

Option description

01 - inlets rounded | 02 - QS | 08 - wiper | 13 - selected A = +/- 0.01 mm | 18 - with rack and pinion | AL - aluminium | OT - brass

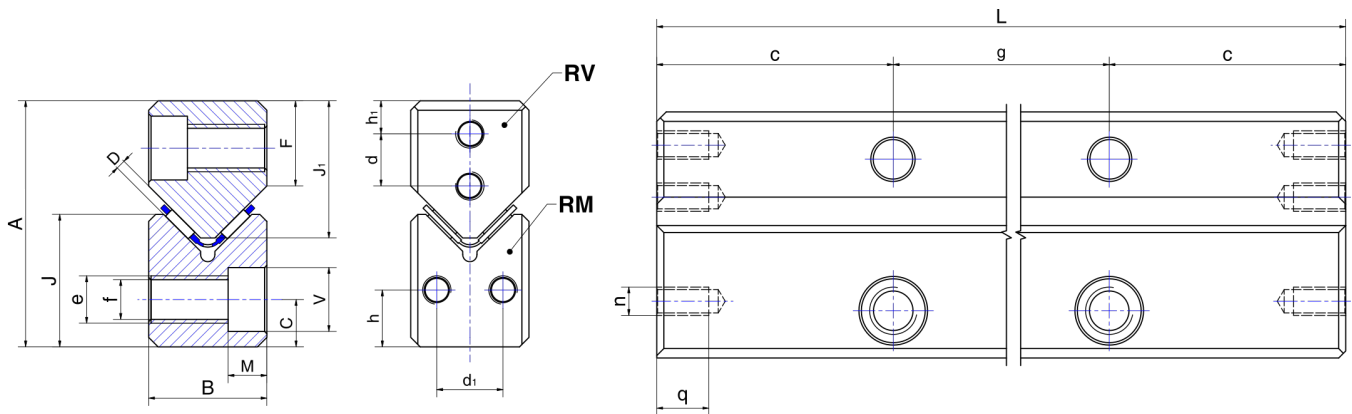

Type	Size	L in mm	Weight in g M rail	Weight in g V rail	g	c	D	A 0 -0.3	B	F	J ₁	J	C	e	f	V	M	n	q	h	h ₁	d	d ₁	Options	Accessories				
RM RV	2025	200	900	900																					Cage type <ul style="list-style-type: none"> • HW15 AL • HW15 OT End pieces <ul style="list-style-type: none"> 01 • GM2025 02 • GM2025.08 13 • GV2025 18 • GV2025.08 • GFM2025 • GFV2025 Fixing screw <ul style="list-style-type: none"> • VM8 				
		300	1365	1350																									
		400	1830	1800																									
		500	2295	2250																									
		600	2760	2700																									
		700	3225	3150	100	50	2	52	25	18	29	28	10	M10	8.5	13.5	8.2	M6	11	10	7	11	14						
		800	3690	3600																									
		900	4155	4050																									
		1000	4620	4500																									
		1100	5085	4950																									
		1200	5550	5400																									
RM RV	2535	300	1905	1965																					Cage type <ul style="list-style-type: none"> • HW20 AL • HW20 OT End pieces <ul style="list-style-type: none"> 01 • GM2535 02 • GM2535.08 13 • GV2535 18 • GV2535.08 • GFM2535 • GFV2535 Fixing screw <ul style="list-style-type: none"> • VM10 				
		400	2540	2620																									
		500	3175	3275																									
		600	3810	3930																									
		700	4445	4585																									
		800	5080	5240	100	50	2.5	62	30	22	35	34	12	M12	10.5	16.5	10.2	M6	11	15	8	12	18						
		900	5715	5895																									
		1000	6350	6650																									
		1100	6985	7205																									
		1200	7620	7860																									

Option description

01 - inlets rounded | 02 - QS | 08 - wiper | 13 - selected A = +/- 0.01 mm | 18 - with rack and pinion | AL - aluminium | OT - brass

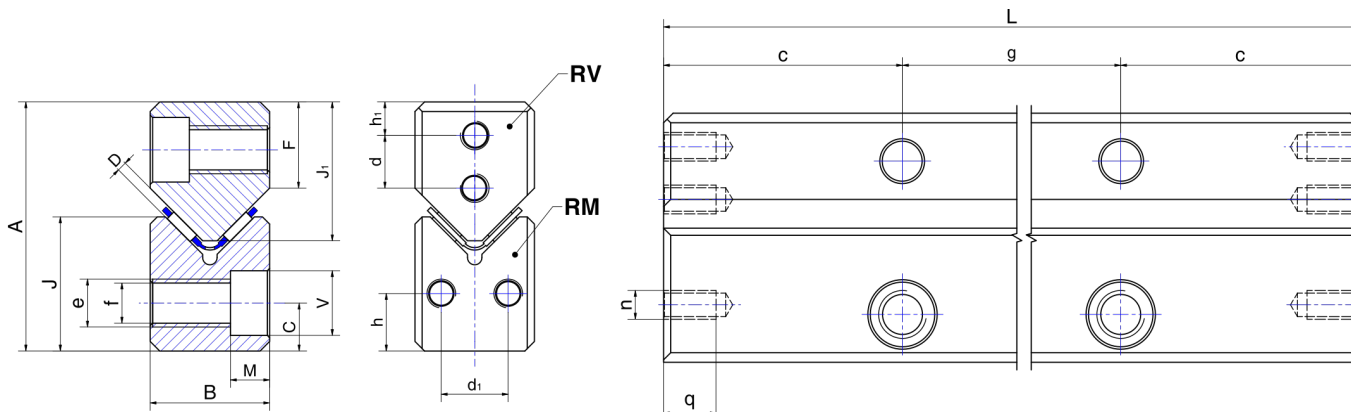

Type	Size	L in mm	Weight in g M rail	Weight in g V rail	g	c	D	A 0 -0.3	B	F	J ₁	J	C	e	f	V	M	n	q	h	h ₁	d	d ₁	Options	Accessories			
RM RV	3045	400	3660	3460																					Cage type • HW25 AL • HW25 OT End pieces 01 • GM3045 02 • GM3045.08 13 • GV3045 18 • GV3045.08 • GFM3045 • GFV3045 Fixing screw • VM12			
		500	4575	4325																								
		600	5490	5190																								
		700	6405	6055																								
		800	7320	6920	100	50	3	74	35	25	40	42.5	14	M14	12.5	18.5	12.2	M6	11	18	10	16	19					
		900	8235	7785																								
		1000	9150	8650																								
		1100	10065	9515																								
		1200	10980	10380																								
RM RV	3555	500	6710	6100																					Cage type • HW30 AL • HW30 OT End pieces 01 • GM3555 02 • GM3555.08 13 • GV3555 18 • GV3555.08 • GFM3555 • GFV3555 Fixing screw • VM12/L			
		600	7410	7320																								
		700	8650	8540																								
		800	9890	9760	100	50	3.5	78	45	25	45	45	14	M14	12.5	18.5	12.2	M6	11	18	12	20	29					
		900	11130	10980																								
		1000	12370	12200																								
		1100	13610	13420																								
		1200	14850	14640																								

Option description

01 - inlets rounded | 02 - QS | 08 - wiper | 13 - selected A = +/- 0.01 mm | 18 - with rack and pinion | AL - aluminium | OT - brass

Description of needle cages

Rails RM/RV are equipped with needle cages.
The rollers in the cages are selected within 0.001 mm.

Determination of cage length and load rating

The type in exam is RM/RV 2025 500. The stroke H is 200 mm and the load $P = 15000$ N.

For the calculation of the cage length (L_g), the formula will be $L_g = L - H/2$ is

$$L_g = 500 - 200/2 = 400 \text{ mm}$$

Therefore, if the rating C/t is 8680 N the system rating will be 104160 N.

The condition $C > P$ should be always verified.

Thus $104160 \text{ N} > 15000 \text{ N}$.

Rail type	Cage type	$\varnothing D$	b_t	S	t	t_1	a	N° rollers x t	C/t (N)
3115	HW10	2	4.8	10	26	4	2	6	5140
92025	HW15	2	6.8	15	32	4.5	2	7	8680
2025	HW15	2	6.8	15	32	4.5	2	7	8680
2535	HW20	2.5	9.8	20.5	45	5.5	2.4	8	17920
3045	HW25	3	13.8	26	60	6	3	9	33750
3555	HW30	3.5	17.8	31.5	75	7	3.2	10	55000

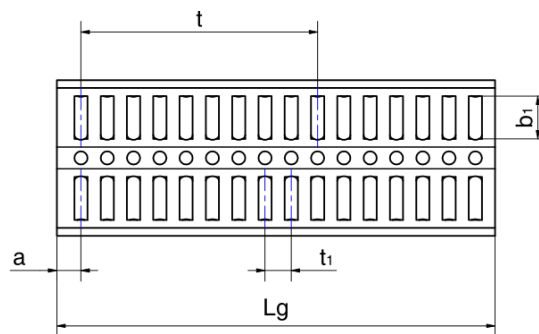
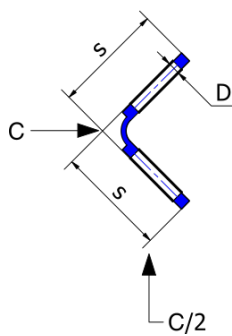

End pieces with or without wiper for horizontal and vertical stroke

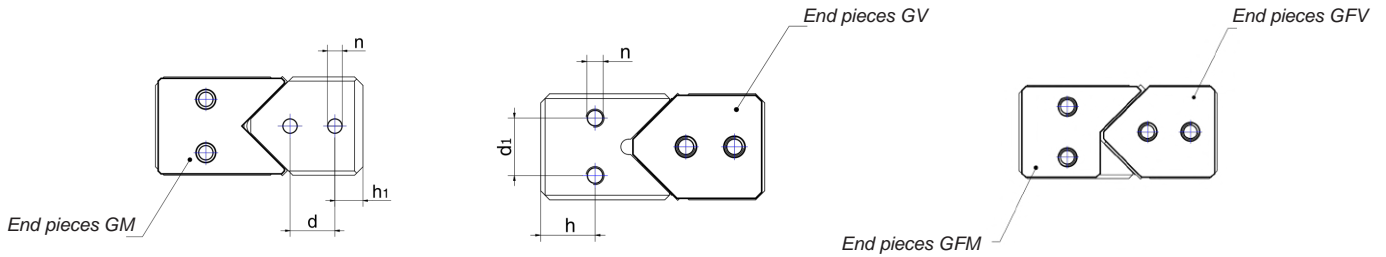

*GM and GV end pieces cannot be mounted together

	RM/RV 3115	RM/RV 92025	RM/RV 2025	RM/RV 2535	RM/RV 3045	RM/RV 3555
a_4	4.7	8	9	11	11	11
a_5	3	3	3	3	3	3
a_6	6.2	10	11	13	13	13
n	M3	M4	M6	M6	M6	M6
d_1	7	10	14	18	19	29
d	7	10	11	12	16	20
h	6.5	11	12	15	18	18
h_1	3.5	6	7	8	10	12

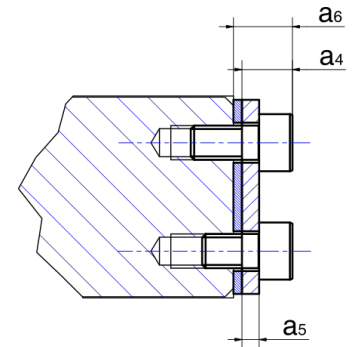

Fixing screws

	RM/RV 3115	RM/RV 92025	RM/RV 2025	RM/RV 2535	RM/RV 3045	RM/RV 3555
l	20	30	40	40	50	60
$\varnothing n$	8	8.5	11.3	13.9	15.8	15.8
$\varnothing o$	3.9	4.6	6.25	7.9	9.5	9.5
d	M5	M6	M8	M10	M12	M12
q	5	6	8	10	12	12
v	12	18	23	22	25	35
t	8	12	17	18	25	25
s	4	5	6	8	10	10
code	VM5	VM6	VM8	VM10	VM12	VM12/L

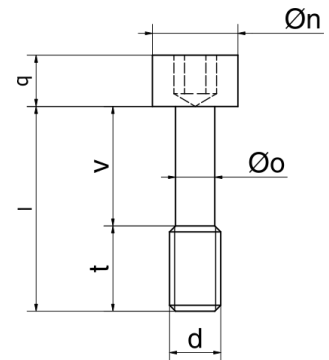

Ordering example

For vertical movement rails RM/RV 2535 700
 Stroke = 480 mm
 2 rails type RM 2535 700
 2 rails type RV 2535 700
 2 cages type HW 20 Lg = 460mm
 4 end pieces type GM2535

For horizontal & vertical movement - rails of different length type
 RM 3045 400 match with rails type RV 3045 800 stroke = 400 mm.
 2 rails type RM 3045 400 chamfered
 2 rails type RV 3045 800
 2 cages type HW 25 Lg = 600mm
 4 end pieces type GV3045

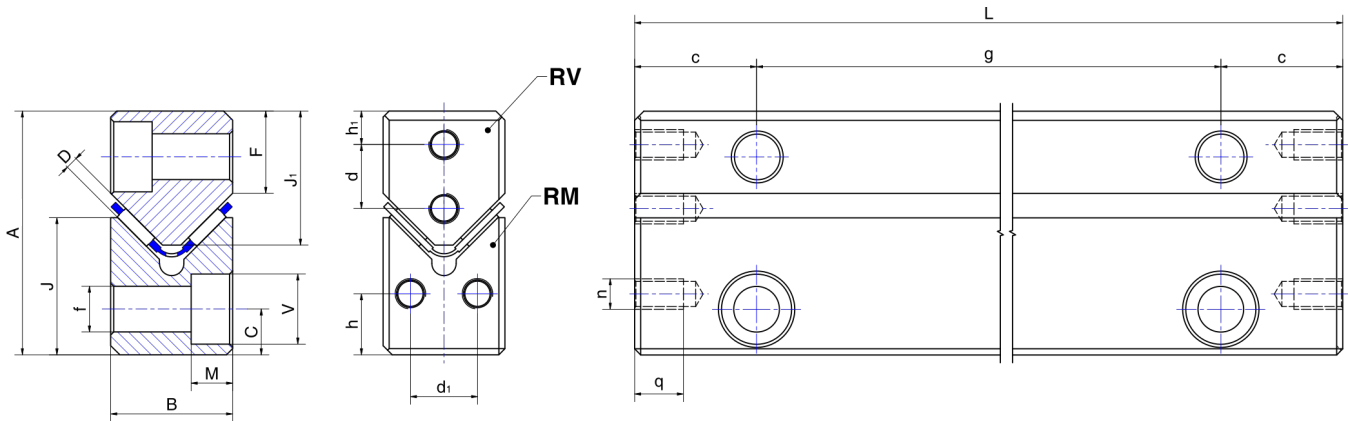

Type	Size	L in mm	Weight in g M rail	Weight in g V rail	g	c* min.	D	A 0 -0.3	B	F	J ₁	J	C	f	V	M	n	q	d	h ₁	h	d ₁	Options	Accessoires
RM RV	3015	100	139	156	1)40	15	2	30	15	10.5	17	15.5	5.5	5.25	8.5	4.5	M3	7	7	5.5	8	7	01 02 13 18	Cage type • HW10 OT End pieces • GM3015 • GM3015.08 • GV3015 • GV3015.08 Fixing screw • VM5
		150	206	232																				
		200	276	311																				
		300	417	469																				
		400	554	623																				
		500	695	781																				
		600	832	935																				
RM RV	4020	100	262	263	2)80	20	2	40	20	13.5	22	22.5	7.5	7.5	11.5	6.8	M5	8	10.5	5.5	10	11	01 02 13 18	Cage type • HW15 AL • HW15 OT End pieces • GM4020 • GM4020.08 • GV4020 • GV4020.08 Fixing screw • VM6
		150	405	407																				
		200	538	541																				
		300	815	820																				
		400	1092	1098																				
		500	1368	1376																				
		600	1635	1644																				

1) for L = 100 mm g = 35 mm

2) for L = 100 mm g = 50 mm

*) $c = [L - (n^\circ \text{ step} \times g)] / 2$

Option description

01 - inlets rounded | 02 - QS | 08 - wiper | 13 - selected A = +/- 0.01 mm | 18 - with rack and pinion | AL - aluminium | OT - brass

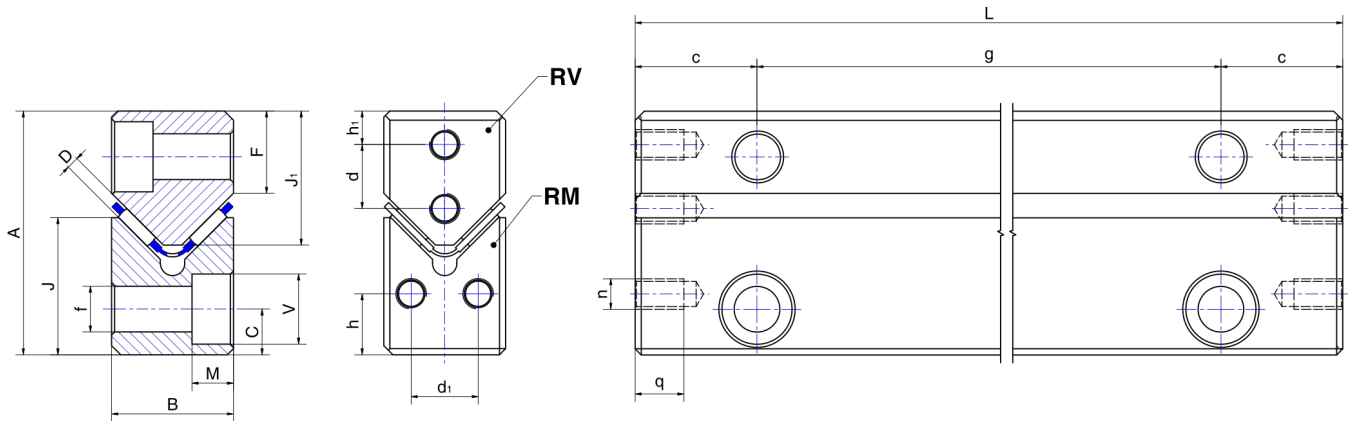

Type	Size	L in mm	Weight in g M rail	Weight in g V rail	g	c* min.	D	A 0 -0.3	B	F	J ₁	J	C	f	V	M	n	q	d	h ₁	h	d ₁	Options	Accessoires
RM RV	5025	100	426	421	80	20	2	50	25	17	28	28	10	7.5	11.5	6.8	M6	9	13	7	12	13	01 02 13 18	<ul style="list-style-type: none"> Cage type • HW15 AL • HM15 OT End pieces • GM5025 • GM5025.08 • GV5025 • GV5025.08 Fixing screw • VM6
		200	871	862																				
		300	1316	1303																				
		400	1761	1744																				
		500	2206	2185																				
		600	2639	2614																				
		700	3084	3054																				
		800	3529	3495																				
		900	3974	3936																				
		1000	4407	4365																				
RM RV	6035	200	1426	1489	100	50	2.5	60	35	20	35	35	11	10	15	9	M6	9	18	8	14	20	01 02 13 18	<ul style="list-style-type: none"> Cage type • HW20 AL • HW20 OT End pieces • GM6035 • GM6035.08 • GV6035 • GV6035.08 Fixing screw • VM8
		300	2143	2239																				
		400	2859	2988																				
		500	3576	3737																				
		600	4293	4487																				
		700	5010	5236																				
		800	5726	5985																				
		900	6443	6735																				
		1000	7160	7484																				

*) $c = [L - (n^\circ \text{ step} \times g)] / 2$

Option description

01 - inlets rounded | 02 - QS | 08 - wiper | 13 - selected A = +/- 0.01 mm | 18 - with rack and pinion | AL - aluminium | OT - brass

Needle cages

Rail type	Cage type	$\varnothing D$	b_1	S	t	t_1	a	N° rollers x t	C/t (N)
3015	HW10	2	4.8	10	26	4	2	6	5140
4020	HW15	2	6.8	15	32	4.5	2	7	8680
5025	HW15	2	6.8	15	32	4.5	2	7	8680
6035	HW20	2.5	9.8	20.5	45	5.5	2.4	8	17920

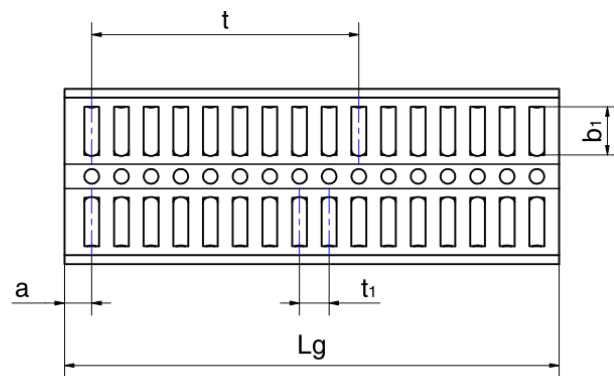
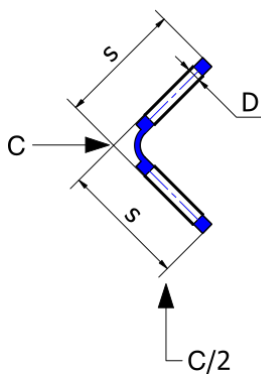

End pieces with or without wiper for horizontal and vertical stroke

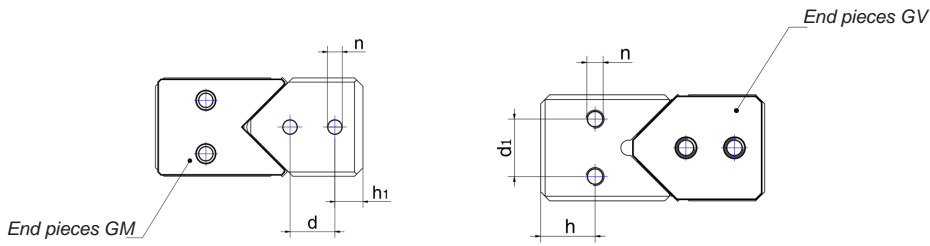

*GM and GV end pieces cannot be mounted together

	RM/RV* 3015	RM/RV 4020	RM/RV 5025	RM/RV 6035
a_4	4.7	5.8	6.3	6.3
a_5	3	3	3	3
a_6	6.2	7.3	7.8	7.8
n	M3	M5	M6	M6
d_1	7	11	13	20
d	7	10.5	10.5	18
h	6.5	9.5	12	14
h_1	5.5	4.8	7	8

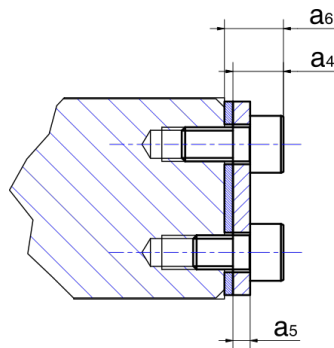

Fixing screws

	RM/RV 3015	RM/RV 4020	RM/RV 5025	RM/RV 6035
l	20	30	30	40
$\varnothing n$	8	8.5	8.5	11.3
$\varnothing o$	3.9	4.6	4.6	6.25
d	M5	M6	M6	M8
q	5	6	6	8
v	12	18	18	23
t	8	8	8	17
s	4	4	4	6
code	VM5	VM6	VM6	VM8

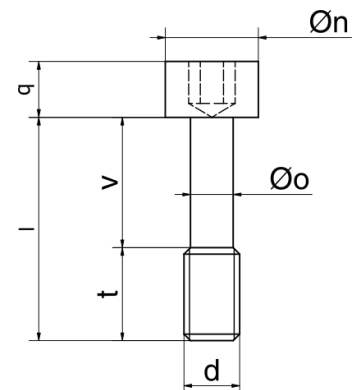



Linear guideway RM/RVA with antifriction material

This rail type completes the system RM/RV. The RVA has the raceways coated with antifriction material. This type is used when the speed is relatively low (20 m/min max) and the rigidity of the system is critical. A set is composed of two rails RM and two rails RVA. The rails RVA and RV are dimensionally interchangeable.

In order to have a good functioning, the temperature of working must be inferior to 50°C. Load capacity per unit in cm² changes from 4500 N (dynamic) ÷ 7500 N (static). Holes and oil grooves can be carried out on request on the RVA rails.

Rail type	Width of bearing surface
RVA 92025	1.05 cm
RVA 2025	1.15 cm
RVA 2535	1.50 cm
RVA 3045	1.75 cm
RVA 3555	2.45 cm



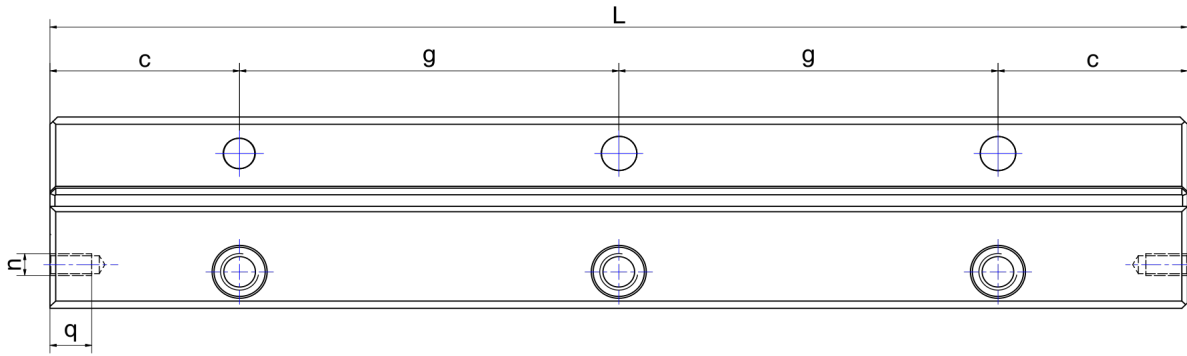

Type	Size	L in mm	Weight in g RM rail	Weight in g RVA rail	g	c	A 0 -0.3	B	J	C	e	f	V	M	n	q	h	d	d ₁	Options	Accessories
RM RVA	92025	200	685	695	100	50	44	22	24	9	M8	6.8	10.5	6.2	M4	10	11	10	10	02 03 13	Fixing screw • VM6
		300	1020	1030																	
		400	1355	1365																	
		500	1690	1700																	
		600	2025	2035																	
		700	2360	-																	
		800	2695	-																	
		900	3030	-																	
		1000	3365	-																	
		1100	3700	-																	
		1200	4035	-																	
RM RVA	2025	200	900	900	100	50	52	25	28	10	M10	8.5	13.5	8.2	M6	11	10	11	14	02 03 13	Fixing screw • VM8
		300	1365	1350																	
		400	1830	1800																	
		500	2295	2250																	
		600	2760	2700																	
		700	3225	-																	
		800	3690	-																	
		900	4155	-																	
		1000	4620	-																	
		1100	5085	-																	
		1200	5550	-																	
RM RVA	2535	300	1905	1965	100	50	62	30	34	12	M12	10.5	16.5	10.2	M6	11	15	12	18	02 03 13	Fixing screw • VM10
		400	2540	2620																	
		500	3175	3275																	
		600	3810	3930																	
		700	4445	-																	
		800	5080	-																	
		900	5715	-																	
		1000	6350	-																	
		1100	6985	-																	
		1200	7620	-																	

Option description

02 - QS | 03 - lubrication holes and groove | 13 - selected A = +/- 0.01 mm

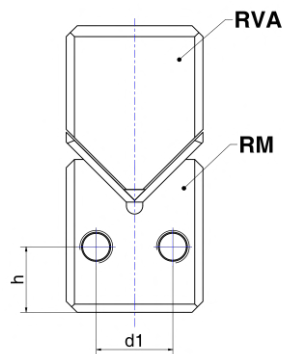
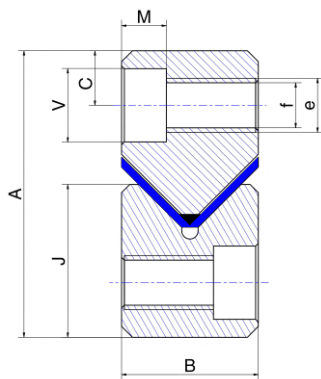

Type	Size	L in mm	Weight in g RM rail	Weight in g RVA rail	g	c	A 0 -0.3	B	J	C	e	f	V	M	n	d	h	d	d ₁	Options	Accessories
RM RVA	3045	400	3660	3460	100	50	74	35	42.5	14	M14	12.5	18.5	12.2	M6	11	18	16	19	02 03 13	Fixing screw • VM12
		500	4575	4325																	
		600	5490	5190																	
		700	6405	-																	
		800	7320	-																	
		900	8235	-																	
		1000	9150	-																	
		1200	10980	-																	
RM RVA	3555	500	6710	6100	100	50	78	45	45	14	M14	12.5	18.5	12.2	M6	11	18	20	29	02 03 13	Fixing screw • VM12/L
		600	7410	7320																	
		700	8650	-																	
		800	9890	-																	
		900	11130	-																	
		1000	12370	-																	
		1100	13610	-																	
		1200	14850	-																	

Option description

02 - QS | 03 - lubrication holes and groove | 13 - selected A = +/- 0.01 mm

Fixing screws RM/RVA

	RM/RVA 3115	RM/RVA 92025	RM/RVA 2025	RM/RVA 2535	RM/RVA 3045	RM/RVA 3555
l	20	30	40	40	50	60
Øn	8	8.5	11.3	13.9	15.8	15.8
Øo	3.9	4.6	6.25	7.9	9.5	9.5
d	M5	M6	M8	M10	M12	M12
q	5	6	8	10	12	12
v	12	18	23	22	25	35
t	8	12	17	18	25	25
s	4	5	6	8	10	10
code	VM5	VM6	VM8	VM10	VM12	VM12/L

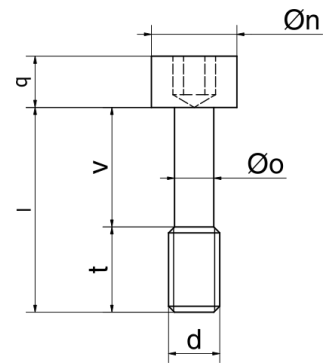
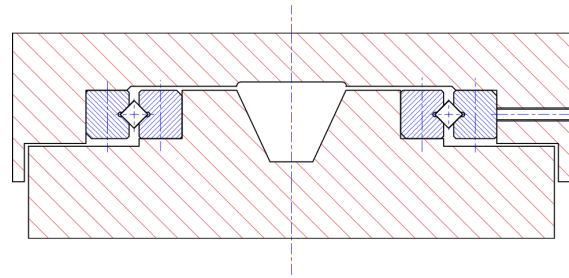
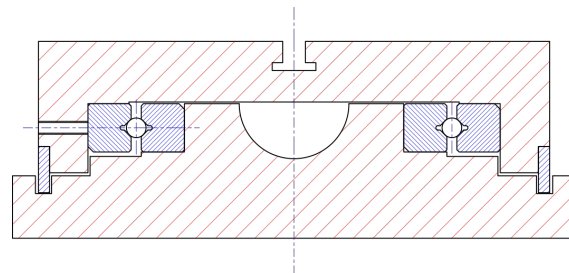

Table arrangements

Application of cross roller way with rails GR
(closed arrangement system)



Application of ball way system with rails GR
(closed arrangement system)



Application of ball way system with rails GR
(open arrangement system)

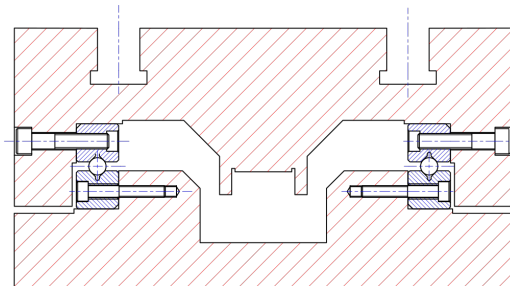

Application of needle way system with rails RM/RV
(closed arrangement system)

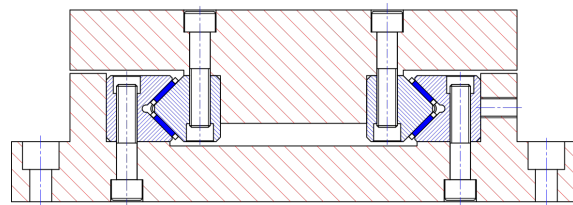

Double raceway rails GRD

The rails GRD have been designed to simplify assemblies and to increase structural rigidity.

They can be used with the table TR and TRL upper portion to increase the economical benefits. They are an integral component of recirculating systems TRKD.



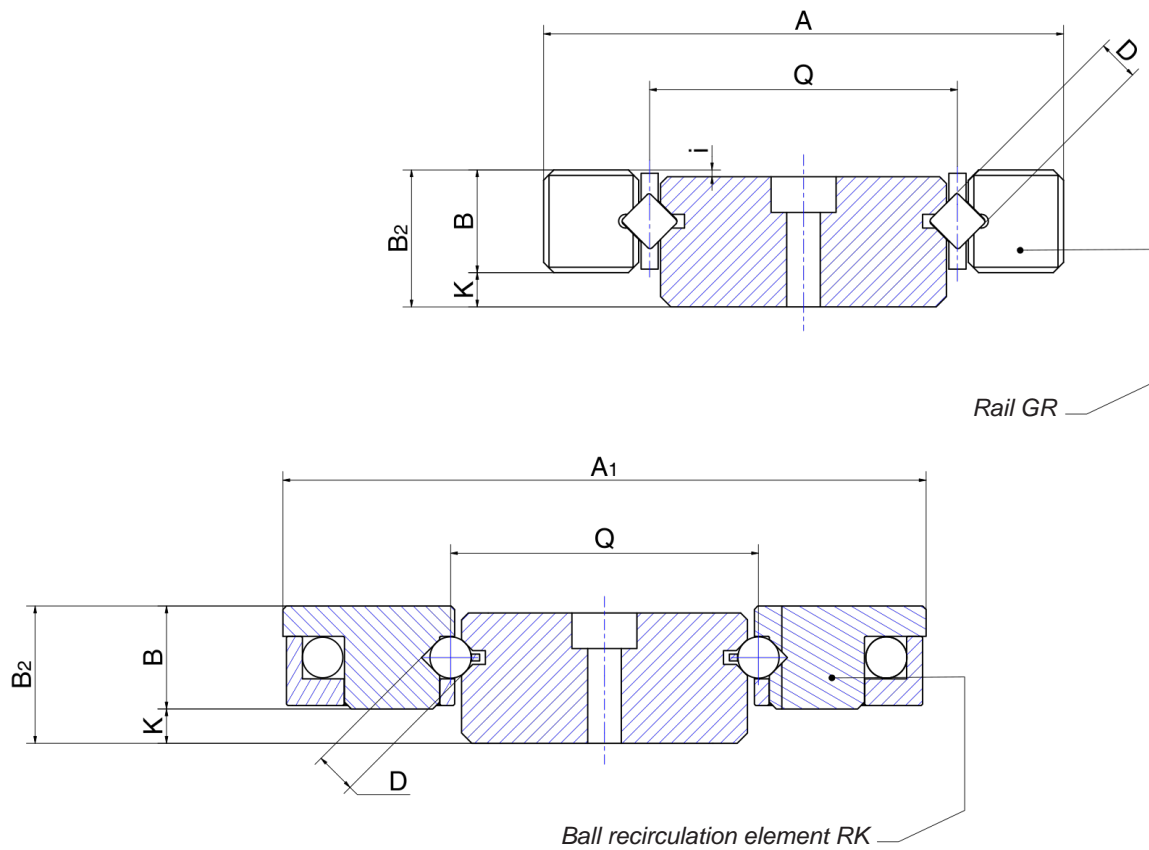
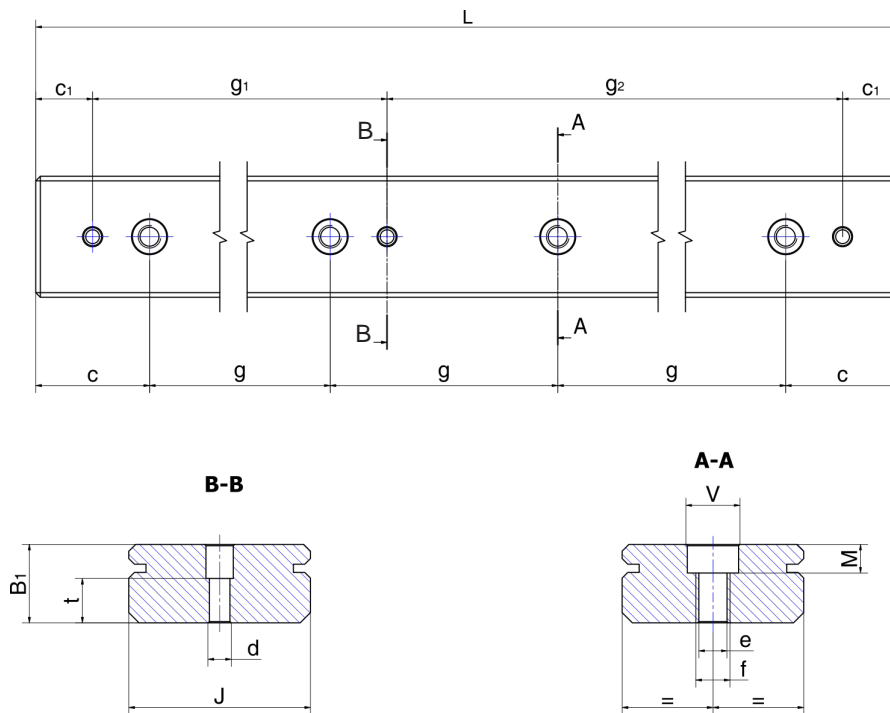

Table designation	K	i	D	Q	B ₂	B	A ₁	A
GRD3 200	4	0.5	3	28	12	8	57	46
GRD3 300								
GRD3 400								
GRD3 500								
GRD6 200	5	1	6	45	20	15	94	76
GRD6 300								
GRD6 400								
GRD6 500								
GRD6 700								
GRD6 800								
GRD6 900								
GRD6 1000								
GRD9 300	6	1	9	72	28	22	150	116
GRD9 400								
GRD9 500								
GRD9 600								
GRD9 700								
GRD9 800								
GRD9 900								
GRD9 1000								



Type	Size	L in mm	g	c	e	f	V	M	J	B ₁	g ₁	g ₂	c ₁	d	t
GRD	3	200	50	25	M5	4.2	7.5	4.2	26.6	11.5	1 x 175	-	12.5	3	6.5
		300									125	150			
		400									187.5	187.5			
		500									225	250			
GRD	6	200	100	50	M6	5.2	9.5	5.2	41.8	19	1 x 150	-	25	6	12
		300									1 x 250	-			
		400									175	175			
		500									210	240			
		600									275	275			
		700									310	340			
		800									375	375			
		900									410	440			
		1000									475	475			
GRD	9	300	100	50	M8	6.8	10.5	6.2	67.4	27	1 x 250	-	25	8	16
		400									175	175			
		500									210	240			
		600									275	275			
		700									310	340			
		800									375	375			
		900									410	440			
		1000									475	475			

How to use the GRD guide

Below you will find some application examples of the GRD guides.

They help to reduce assembly time and cost. In fact, it is sufficient to provide a ground surface upon which the rail GRD is mounted.

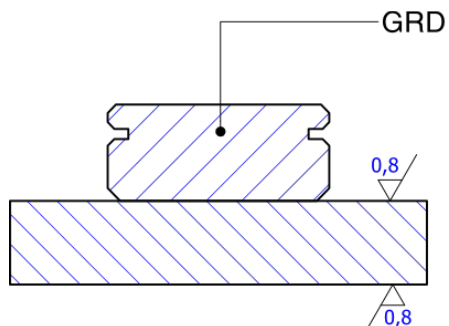

The rails GRD have been designed to eliminate the operations required to prepare the structure on which one normally would mount rails type GR.

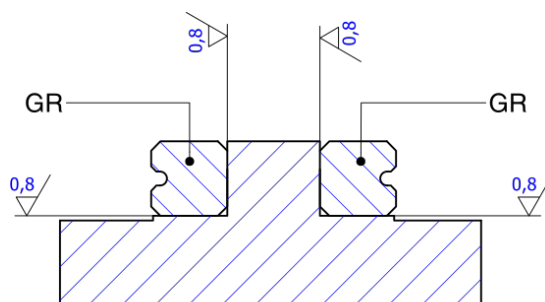

They could be also used as a mobile portion.

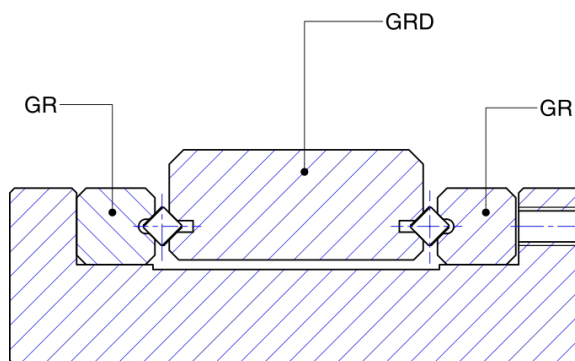

Recirculating linear unit RK

The recirculating linear units RK are mainly composed of three parts. The former is a central body in coro hardened steel (hardness HRC 60 ± 2) whose purpose is to hold the charge. The balls are conveyed to the V-shaped rolling track of the rail, suitably kept by a polyamide block as to hold and give them the direction.

The recirculating linear unit RK, once coupled with rails GR or GRD, allow linear movements limited only by the length of the rails themselves.

It is important to mention the possibility to use on the same way, several units with independent motion.

Max. admitted speed: 120 m/min.

Max. admitted acceleration: 50 m/sec²



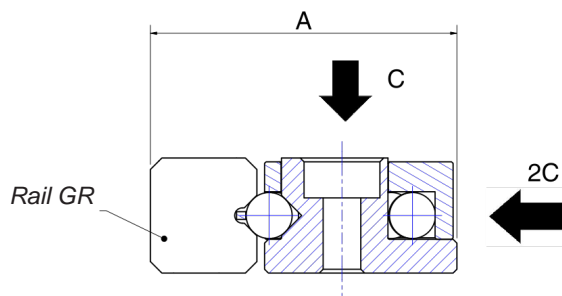
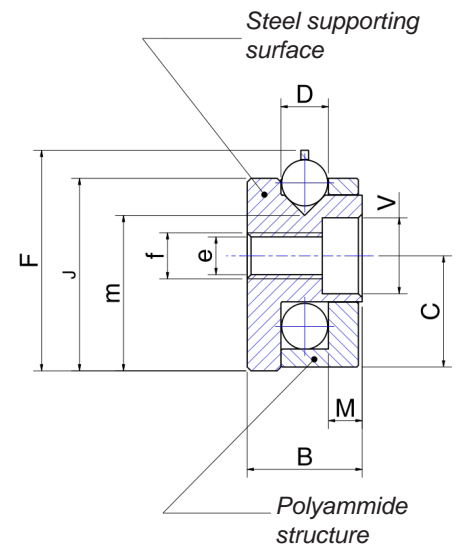
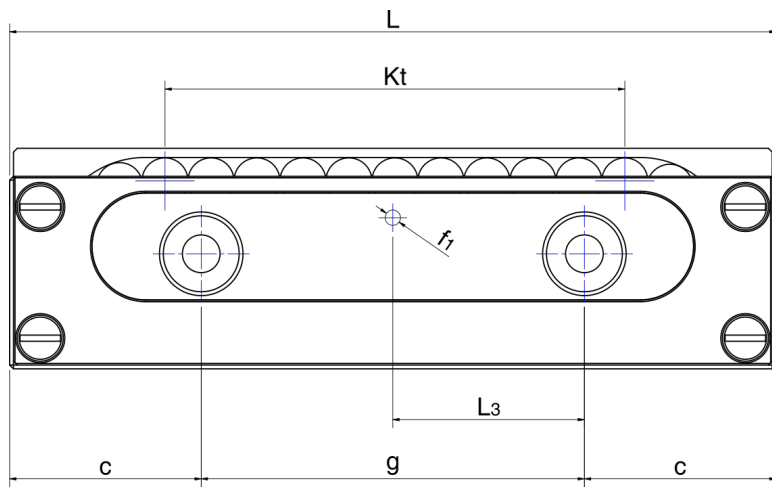

Recirculating unit type	RK3 075	RK6 100	RK6 150	RK9 150	RK9 200
L	75	100	150	150	200
B	8	15	15	22	22
F	16.9	29	29	45.2	45.2
g	25	50	2 x 50	100	100
c	25	25	25	25	50
J	14.7	25.7	25.7	38.7	38.7
C	9	15	15	26	26
e	M4	M6	M6	M8	M8
f	3.3	5.2	5.2	6.8	6.8
V	6	9.5	9.5	10.5	10.5
M	3.2	5.2	5.2	6.2	6.2
D	3	6	6	9	9
Kt	48	60	102	90	144
Max. allowable load C (N)	425	715	1170	1650	2550
A	23.5	40	40	61	61
L₃	12.5	25	25	50	50
m	11.5	19.7	19.7	32.4	32.4
f₁	Ø 1.5	Ø 2	Ø 2	Ø 3	Ø 3

Special products

Rosa Sistemi S.r.l., in a global supply market that ranges from the smallest and most compact linear motion systems to the largest and more complex ones, is able to offer technological solutions for the most demanding users operating in the most innovative fields of Hightech industry.

Thanks to the know-how acquired in the production of individual components and the significant investments made in research and development, our company has developed high precision and complex mechanical linear systems.

The relationship of trust between Rosa Sistemi and the customer is the base for the success of our company.

Innovative solutions in the production of precision linear components as:

- Customized linear systems
- Mechanical parts according to drawing

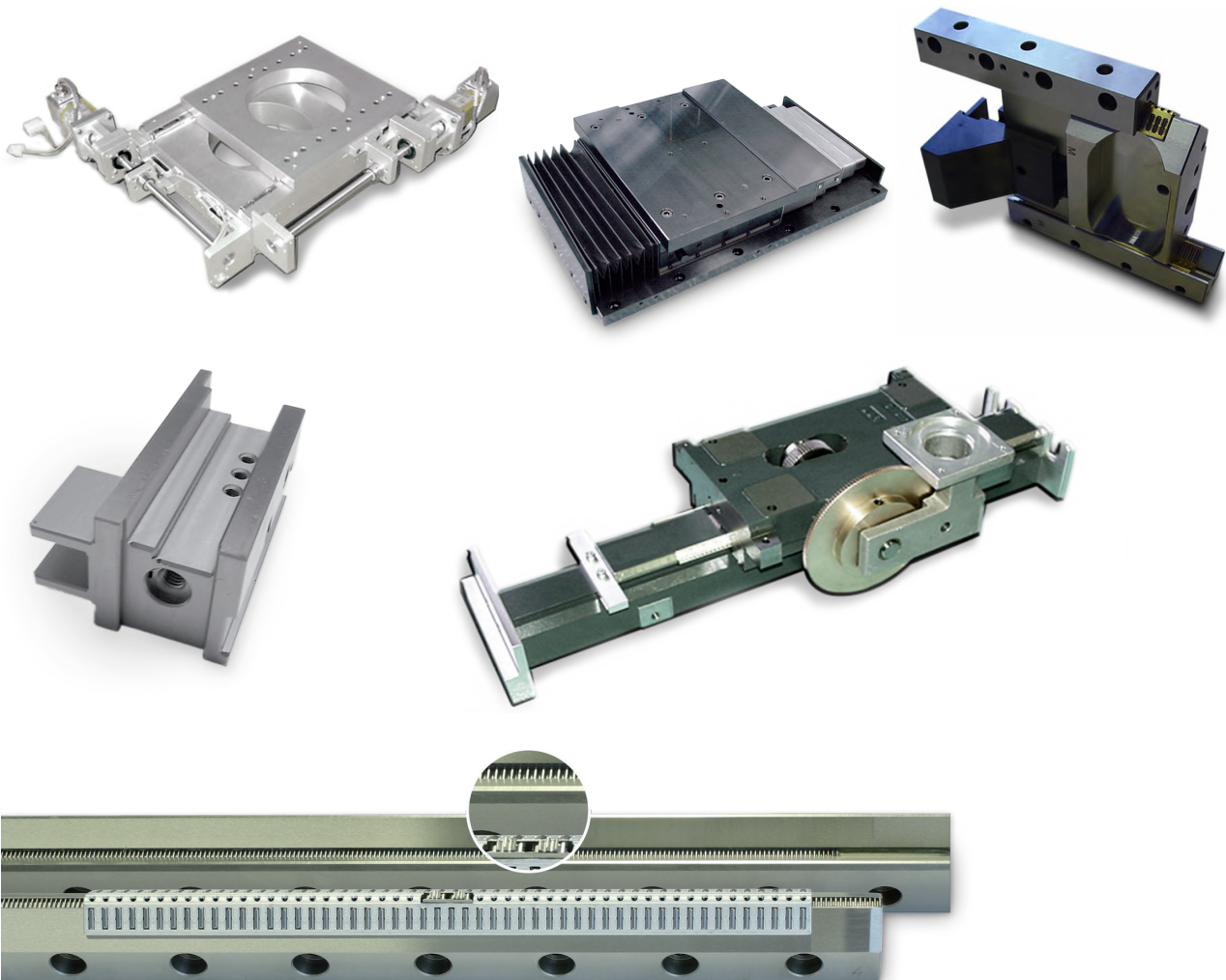



Frictionless table TR (steel and cast iron)

Tables TR1-2 are derived from steel and tables TR3-6-9 are derived from cast iron castings. They provide a clear example of applications for GR-systems. They are carefully machined and molded to provide high precision movement. They are standardized for stroke of 10 to 950 mm and load rating of 250 N to 48100 N. The base is provided with standardized holes for mounting. The mobile portion can be used to support predetermined tooling.

The customer can drill and thread the surface to suit his application to do so, the table should be disassembled. If this is not possible, the holes should be blind and care should be taken to insure protection to avoid chip penetration. Each table utilizes rails and cages suitable to its application.

On the table TR9 it is possible to use rails RM/RV or RM/RVA 92025 in order to increase the table load capacity.

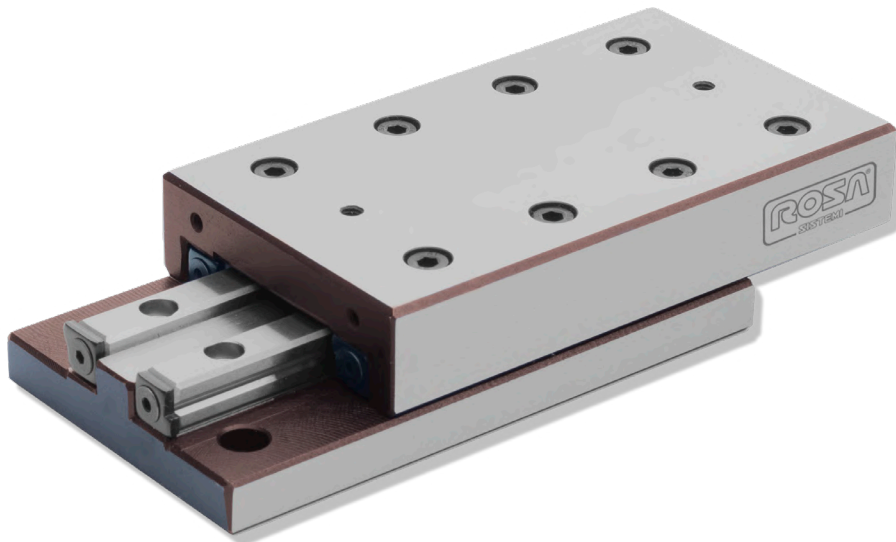

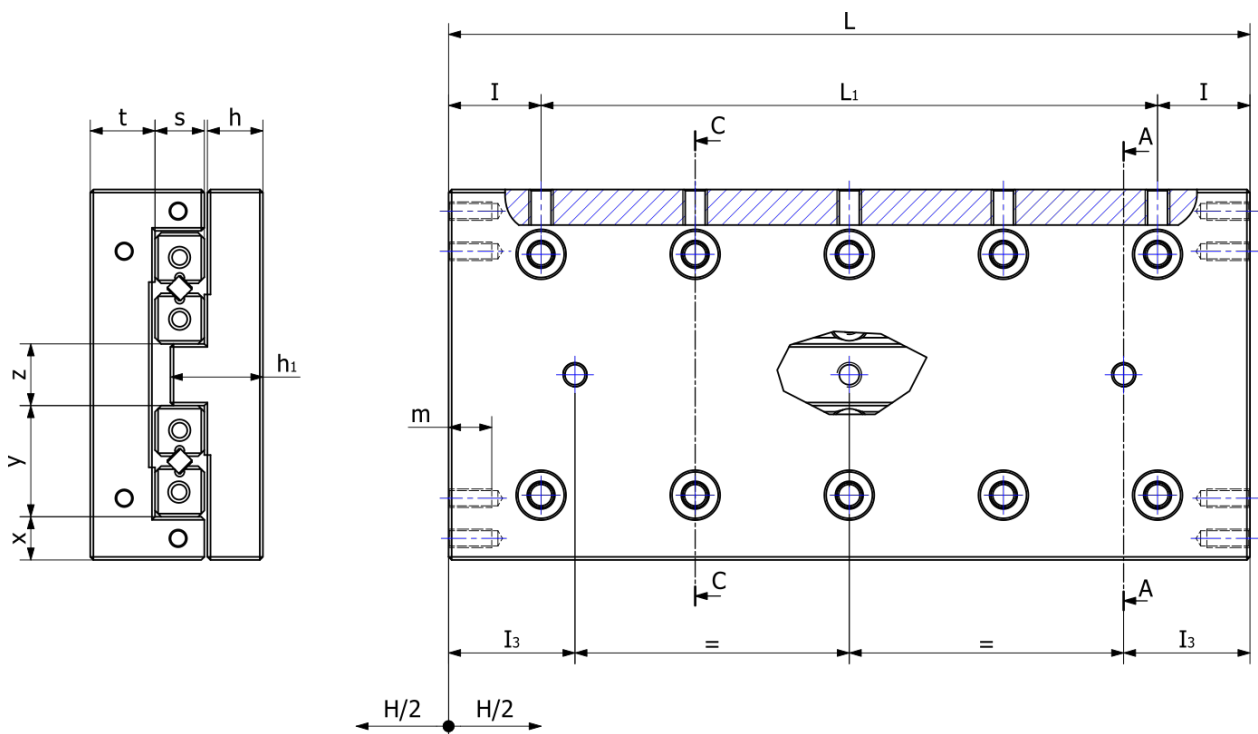

Table designation	Stroke H	L (± 0.1)	L ₁	Ø Roller	h	h ₁	l	l ₃	m	s	t	x	y	z
TR1 25	10	25	1 x 10	1.5	5.5	9	7.5	2.5	6	4	7	3.8	8.5	5
TR1 35	18	35	2 x 10					4.5						
TR1 45	25	45	3 x 10					6						
TR1 55	32	55	4 x 10					7.5						
TR1 65	40	65	5 x 10					8.5						
TR1 75	45	75	6 x 10					11						
TR1 85	50	85	7 x 10					13.5						
TR1 95	55	95	8 x 10					16						
TR1 105	60	105	9 x 10					18.5						
TR2 35	18	35	1 x 15	2	6.5	11	10	3	6	6	7.8	4.8	12	6
TR2 50	30	50	2 x 15					4.5						
TR2 65	40	65	3 x 15					7						
TR2 80	50	80	4 x 15					9.5						
TR2 95	60	95	5 x 15					12						
TR2 110	70	110	6 x 15					14.5						
TR2 125	80	125	7 x 15					17						
TR2 140	90	140	8 x 15					19.5						
TR2 155	100	155	9 x 15					22						

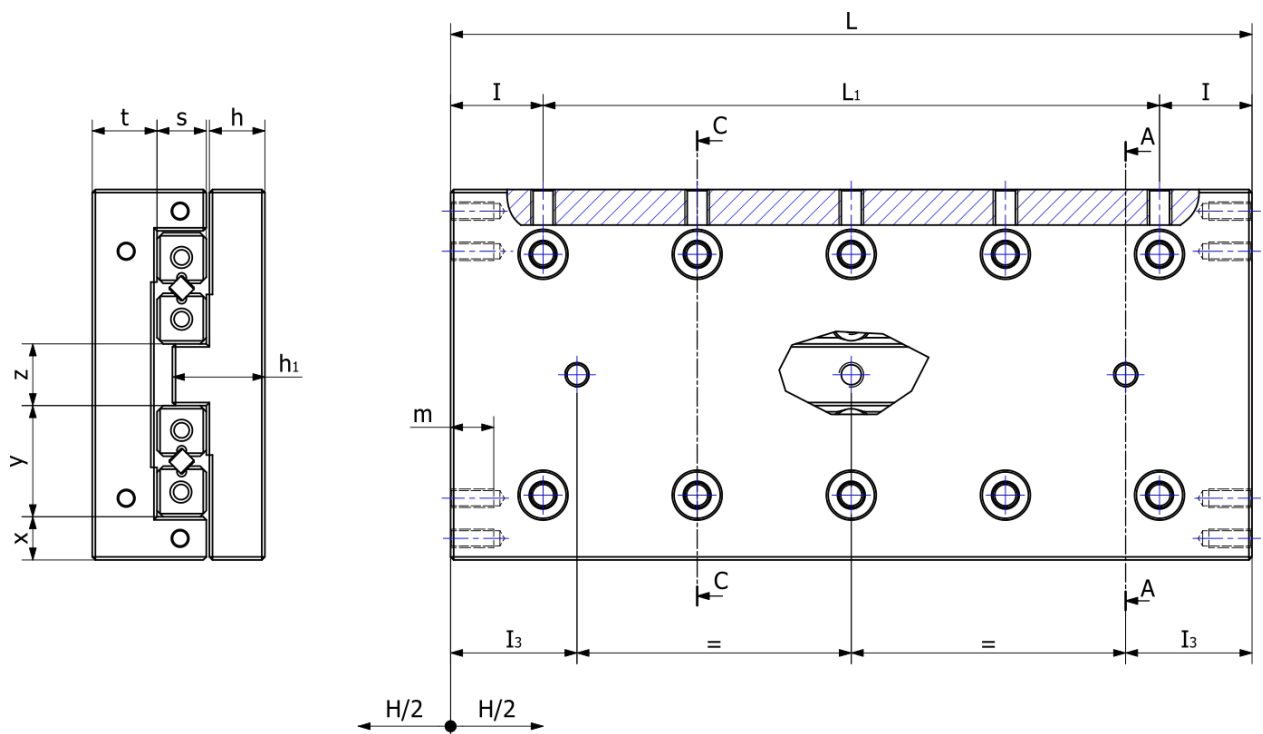
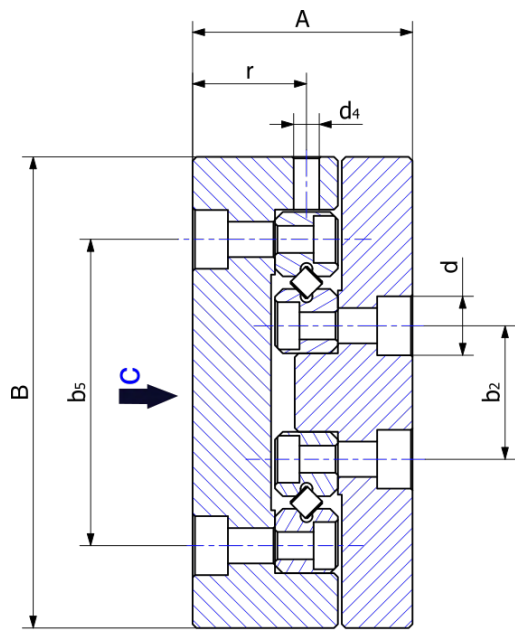
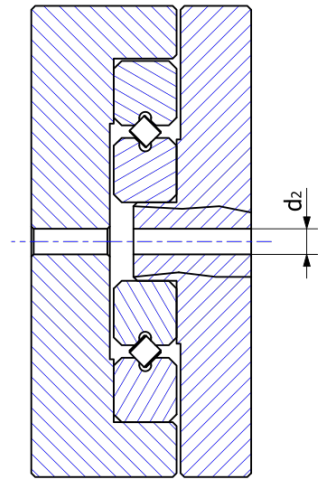
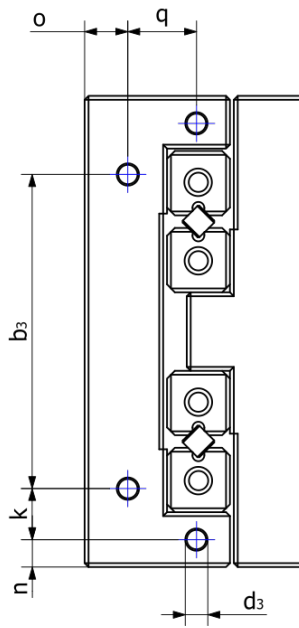

Table designation	Stroke H	L (± 0.1)	L ₁	Ø Roller	h	h ₁	l	l ₃	m	s	t	x	y	z
TR3 55	30	55	1 x 25	3	9	15	15	5.5	7	8	10.5	7	18	10
TR3 80	45	80	2 x 25					10.5						
TR3 105	60	105	3 x 25					15.5						
TR3 130	75	130	4 x 25					20.5						
TR3 155	90	155	5 x 25					25.5						
TR3 180	105	180	6 x 25					30.5						
TR3 205	130	205	7 x 25					30.5						
TR6 110	60	110	1 x 50	6	13	22	30	16.5	8	15	16	12	31	14
TR6 160	95	160	2 x 50					24						
TR6 210	130	210	3 x 50					31.5						
TR6 260	165	260	4 x 50					39						
TR6 310	200	310	5 x 50					46.5						
TR6 360	235	360	6 x 50					54						
TR6 410	265	410	7 x 50					64						
TR9 210	130	210	1 x 100	9	16	29	55	27	10	22	21	14.5	44	28
TR9 310	180	310	2 x 100					52						
TR9 410	350	410	3 x 100					17						
TR9 510	450	510	4 x 100					17						
TR9 610	550	610	5 x 100					17						
TR9 710	650	710	6 x 100					17						
TR9 810	750	810	7 x 100					17						
TR9 910	850	910	8 x 100					17						
TR9 1010	950	1010	9 x 100					17						

Standardized drilling on the upper structure as per drawing and quote above for TRL1 - TRL2 (sign "B" execution on order).



C - C



A - A

Table designation	A	B	b ₅	b ₂	b ₃	d	d ₂	d ₃	d ₄	k	n	o	q	r	Maximum allowable load C (N)	Table weight (kg)
TR1 25	17 ±0.1	30 +0.1 -0.4	18.4	8.6	12	4.1	M2	M2	M2.5	-	-	2.5	-	9	250	0.080
TR1 35															350	0.116
TR1 45															450	0.150
TR1 55															550	0.179
TR1 65															650	0.213
TR1 75															750	0.246
TR1 85															900	0.278
TR1 95															1000	0.312
TR1 105															1150	0.349
TR2 35	21 ±0.1	40 +0.1 -0.4	25	11	16	6	M3	M2	M3	-	-	3.5	-	11	425	0.183
TR2 50															595	0.263
TR2 65															850	0.348
TR2 80															1020	0.425
TR2 95															1275	0.504
TR2 110															1445	0.586
TR2 125															1700	0.670
TR2 140															1870	0.750
TR2 155															2125	0.832

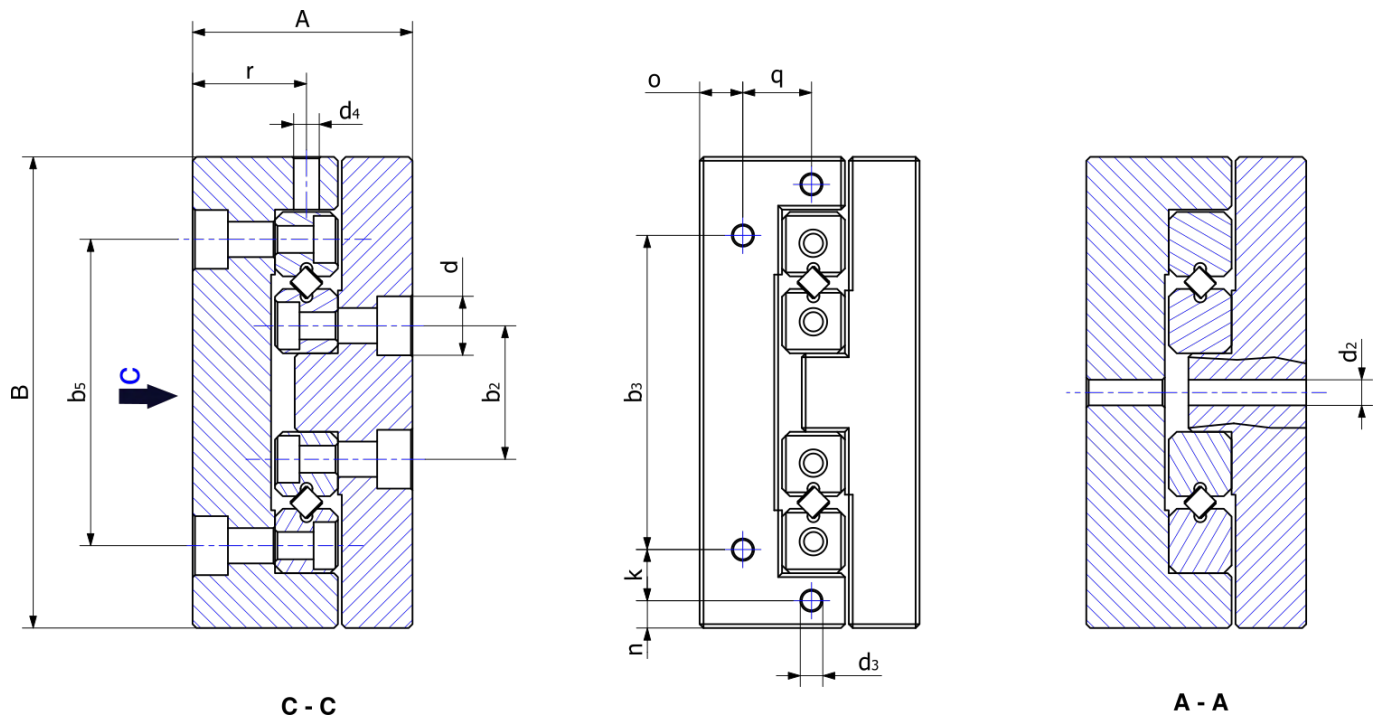

Table designation	A	B	b ₅	b ₂	b ₃	d	d ₂	d ₃	d ₄	k	n	o	q	r	Maximum allowable load C (N)	Table weight (kg)
TR3 55	28 ±0.1	60 +0.1 -0.4	39	17	40	7.5	M4	M3	M4	-	-	5.5	-	14.5	910	0.57
TR3 80															1300	0.8
TR3 105															1820	1.3
TR3 130															2210	1.26
TR3 155															2730	1.49
TR3 180															3120	1.72
TR3 205															3510	1.95
TR6 110	45 ±0.1	100 ±0.2	64	26	60	11	M5	M4	M5	16	4	8	15	23.5	3710	3.07
TR6 160															5830	4.46
TR6 210															7420	5.85
TR6 260															9540	7.24
TR6 310															11660	8.63
TR6 360															13250	10.02
TR6 410															15370	11.41
TR9 210	60 ±0.1	145 ±0.2	98	46	90	14.5	M8	M4	M6	22.5	5	11	20	32	11700	11.8
TR9 310															18200	17.3
TR9 410															20800	22.8
TR9 510															24700	28.3
TR9 610															29900	33.8
TR9 710															33800	39.3
TR9 810															39000	44.8
TR9 910															42900	50.3
TR9 1010															48100	55.8

Mounting holes on the lower part of tables TR

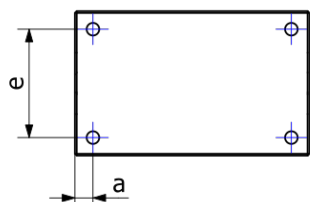
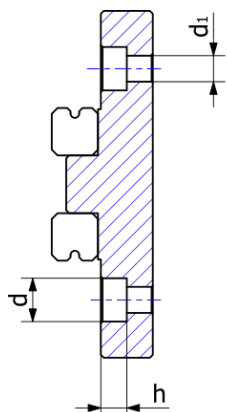

Fig. 1

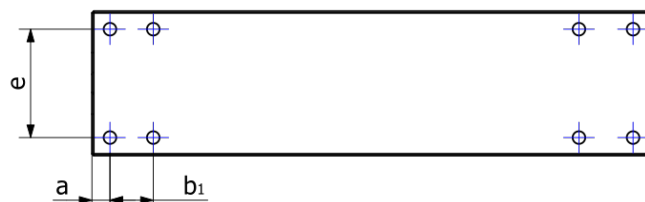

Fig. 2

Matched tables can be supplied with tolerance on A ($A-A_1$) quote of ± 0.01 mm

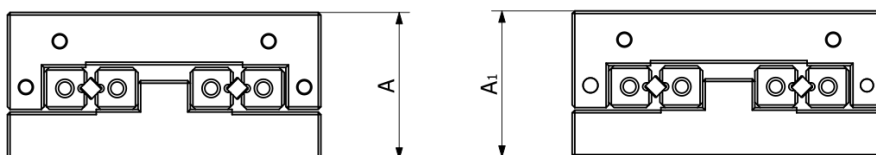

Table designation	a	b_1	Fig.	e	h	d	d_1
TR1 25	3.5	10	1	22	2.5	4.1	2.5
TR1 35			1				
TR1 45			1				
TR1 55			2				
TR1 65			2				
TR1 75			2				
TR1 85			2				
TR1 95			2				
TR1 105			2				
TR2 35	5	15	1	30	3.5	6	3.5
TR2 50			1				
TR2 65			1				
TR2 80			2				
TR2 95			2				
TR2 110			2				
TR2 125			2				
TR2 140			2				
TR2 155			2				

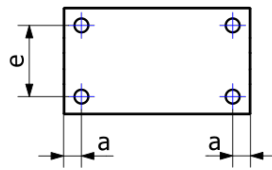
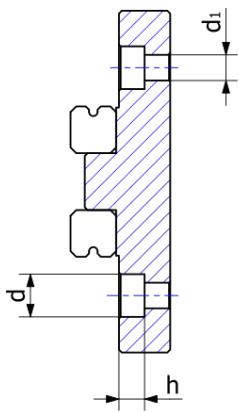

Fig. 1

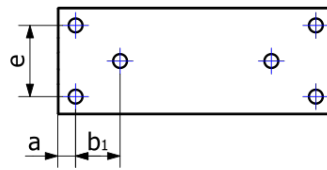

Fig. 3

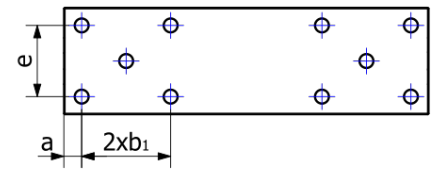

Fig. 4

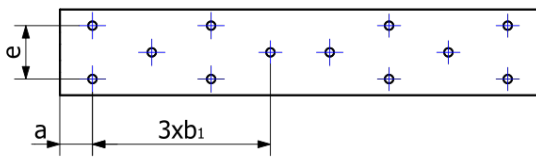

Fig. 5

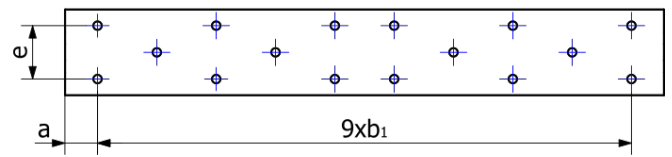

Fig. 6

Matched tables can be supplied with tolerance on A (A-A₁) quote of ± 0.01 mm

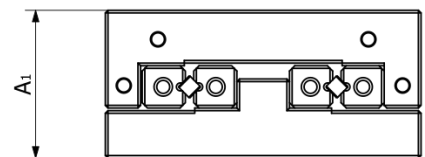
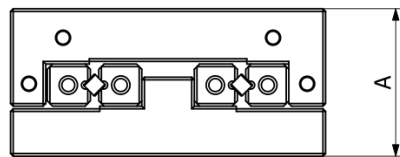
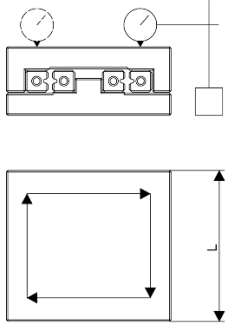
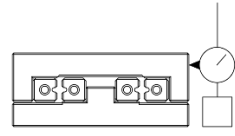
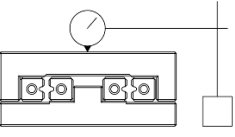
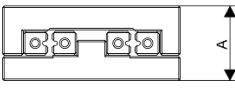

Table designation	a	b ₁	Fig.	e	h	d	d ₁
TR3 55	10	25	1	40	5	7.5	4.5
TR3 80			1				
TR3 105			1				
TR3 130			1				
TR3 155			3				
TR3 180			3				
TR3 205			4				
TR6 110	10	50	1	60	7	11	7
TR6 160			1				
TR6 210			3				
TR6 260			3				
TR6 310			3				
TR6 360			4				
TR6 410			4				
TR9 210	55	100	1	90	9	14	9
TR9 310			1				
TR9 410			3				
TR9 510			3				
TR9 610			4				
TR9 710			4				
TR9 810			5				
TR9 910			5				
TR9 1010			6				

Tolerances allowed for tables TR

Table lenght (mm) / Tolerance (μm)			from 25 to 50	from 55 to 100	from 110 to 160	from 180 to 310	from 410 to 510	from 610 to 710	from 810 to 1010
	Flatness checked on longitudinal and transversal axis of the table	Admitted error	5	10	15	20	25	30	40
	Parallelism (Lateral)	Admitted error	2	3	3	4	5	6	6
	Parallelism (Upper Portion) measured on the center line	Admitted error	2	2	3	3	4	4	5
	Height A measure with micrometer	Admitted error	± 100						



Frictionless table TRL (light alloy)

What was said previously for table TR is also valid for the series made of light alloy. However, differences as far as sizing and load rating are present. The height A is smaller for type TRL1, TRL3 and TRL6 series (see dimension table).

The series TRL6 has two additional sizes with respect to its cast iron counterpart TR6. While the series TRL3 includes four additional sizes. The load ratings are lower than series TR and so is the weight. Therefore, the table TRL are indicated for movements with high acceleration since their mass is lower and consequently the inertia. Tables of series TRL are supplied with attaching holes.



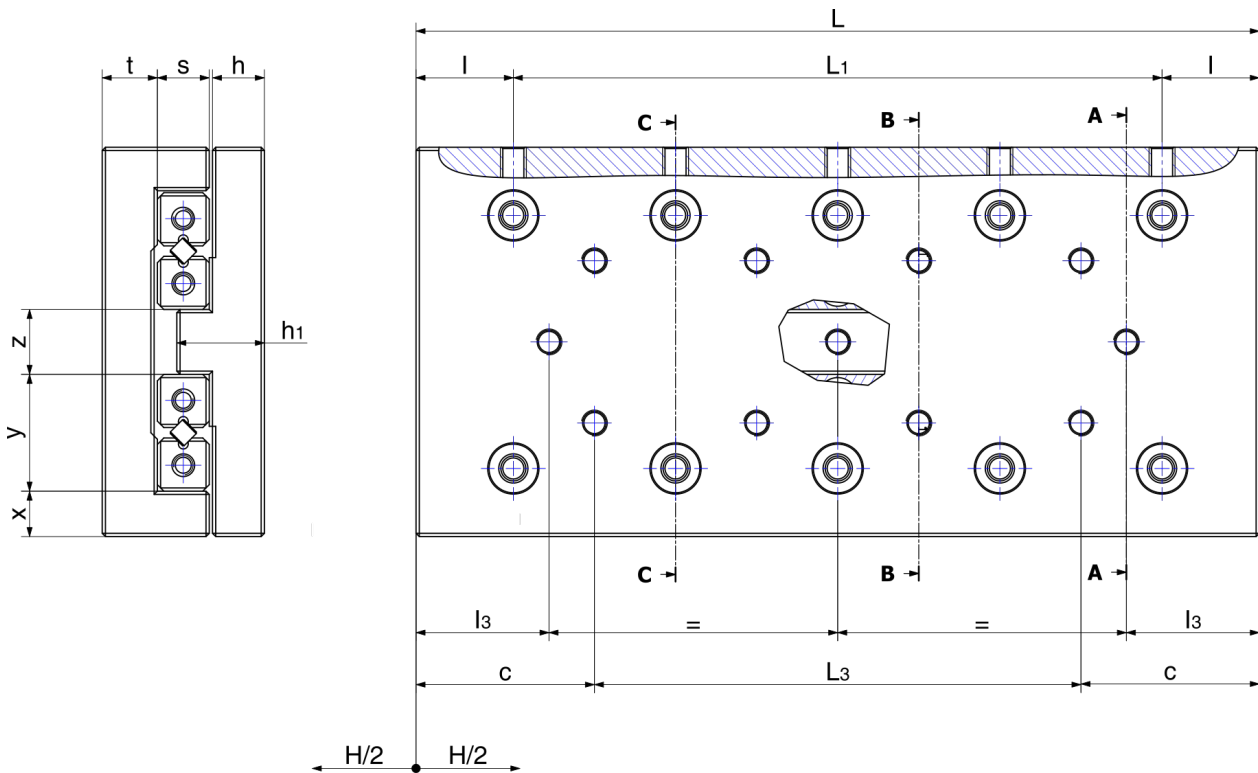

Table designation	Stroke H	L (± 0.1)	\emptyset Roller	L ₁	L ₃	c	h	h ₁	l	l ₃	s	t	x	Y	z
TRL1 25	10	25	1.5	1 x 10	-	12.5	4.1	7.6	7.5	3.5	4	4.5	4	8.5	5
TRL1 35	18	35		2 x 10	1 x 10					4.5					
TRL1 45	25	45		3 x 10	2 x 10					6					
TRL1 55	32	55		4 x 10	3 x 10					7.5					
TRL1 65	40	65		5 x 10	4 x 10					8.5					
TRL1 75	45	75		6 x 10	5 x 10					11					
TRL1 85	50	85		7 x 10	6 x 10					13.5					
TRL1 95	55	95		8 x 10	7 x 10					15					
TRL1 105	60	100		9 x 10	8 x 10					17.5					
TRL2 35	18	35	2	1 x 15	-	17.5	6.5	11	10	3	6	8	5	12	6
TRL2 50	30	50		2 x 15	1 x 15					4.5					
TRL2 65	40	65		3 x 15	2 x 15					7					
TRL2 80	50	80		4 x 15	3 x 15					9.5					
TRL2 95	60	95		5 x 15	4 x 15					12					
TRL2 110	70	110		6 x 15	5 x 15					14.5					
TRL2 125	80	125		7 x 15	6 x 15					17					
TRL2 140	90	140		8 x 15	7 x 15					19.5					
TRL2 155	100	155		9 x 15	8 x 15					22					

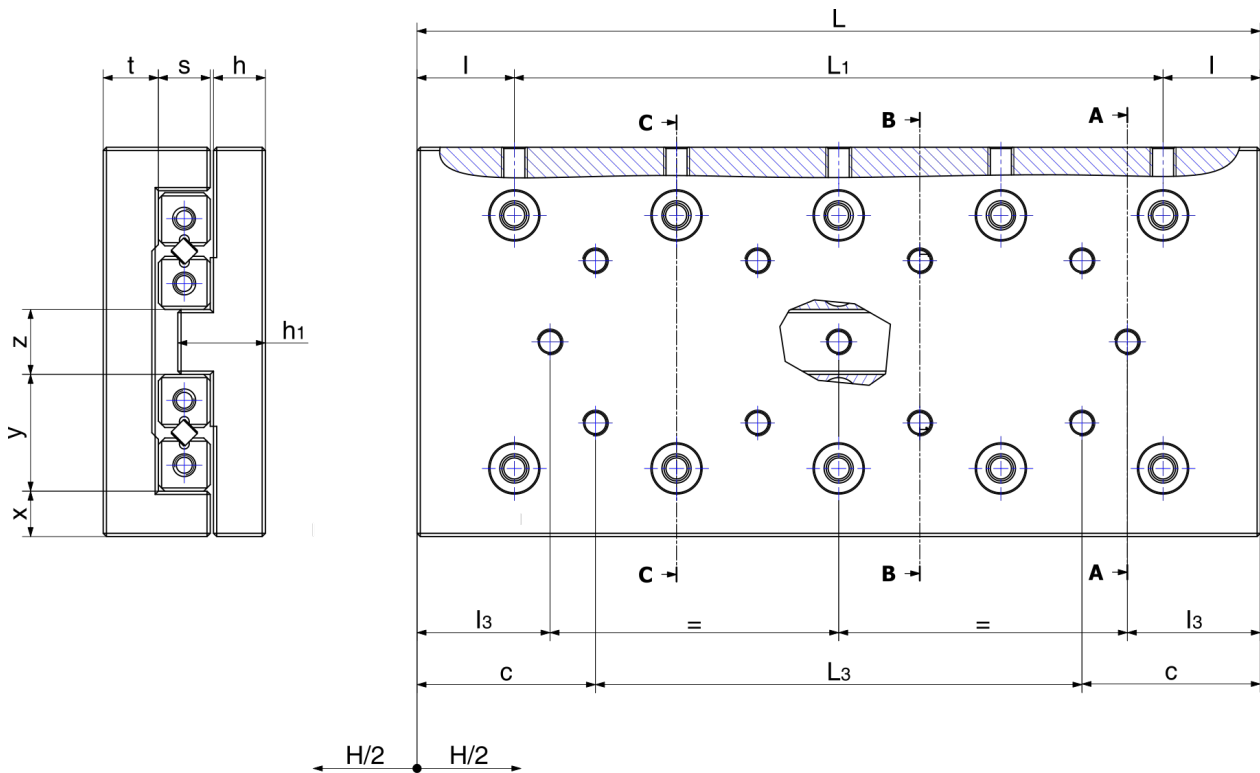

Table designation	Stroke H	L (± 0.1)	\varnothing Roller	L_1	L_3	c	h	h_1	l	l_3	s	t	x	Y	z
TRL3 55	30	55	3	1 x 25	-	27.5	8.2	12.5	15	5.5	8	8.5	7	18	10
TRL3 80	45	80		2 x 25	1 x 25					10.5					
TRL3 105	60	105		3 x 25	2 x 25					15.5					
TRL3 130	75	130		4 x 25	3 x 25					20.5					
TRL3 155	90	155		5 x 25	4 x 25					25.5					
TRL3 180	105	180		6 x 25	5 x 25					30.5					
TRL3 205	130	205		7 x 25	6 x 25					30.5					
TRL3 230	155	230		8 x 25	7 x 25					30.5					
TRL3 255	180	255		9 x 25	8 x 25					30.5					
TRL3 280	205	280		10 x 25	9 x 25					30.5					
TRL3 305	230	305		11 x 25	10 x 25					30.5					
TRL6 110	60	110	6	1 x 50	-	55	11.5	19.5	30	16	15	13	12	31	14
TRL6 160	95	160		2 x 50	1 x 50					23.5					
TRL6 210	130	210		3 x 50	2 x 50					31					
TRL6 260	165	260		4 x 50	3 x 50					38.5					
TRL6 310	200	310		5 x 50	4 x 50					46					
TRL6 360	265	360		6 x 50	5 x 50					38.5					
TRL6 410	280	410		7 x 50	6 x 50					56					
TRL6 460	325	460		8 x 50	7 x 50					58.5					
TRL6 510	380	510		9 x 50	8 x 50					56					

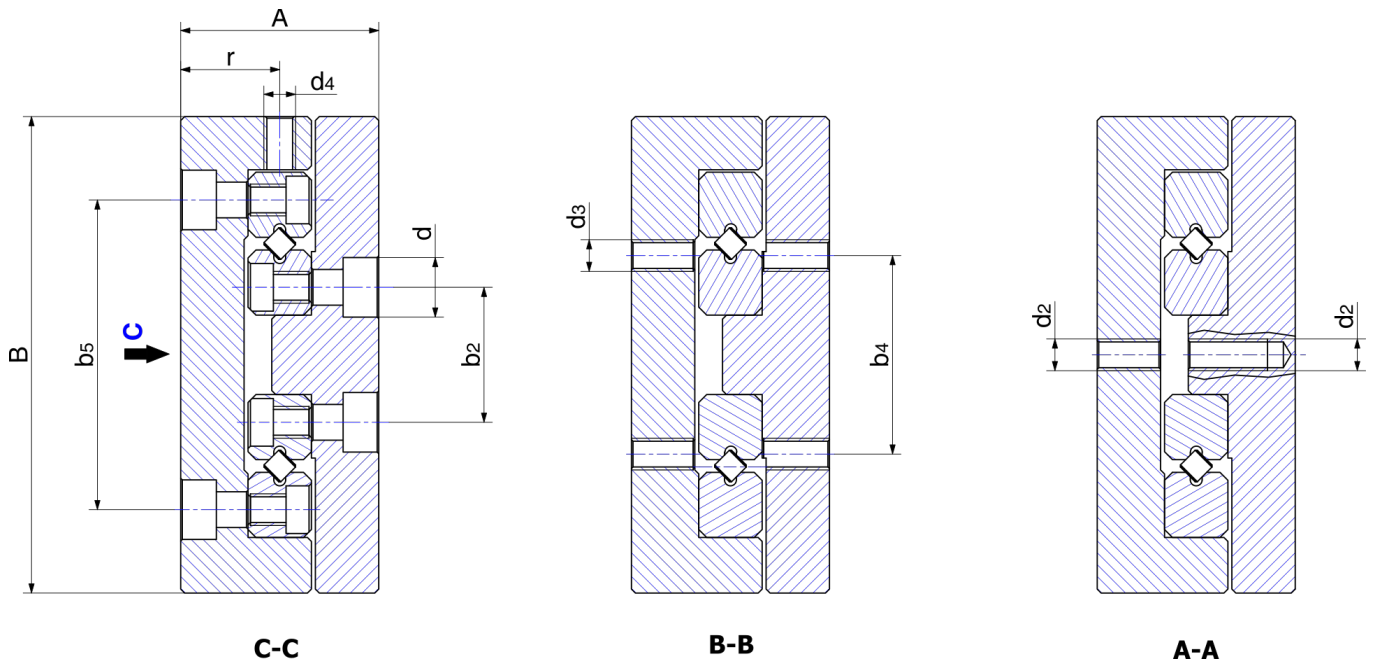

Table designation	A	B	b ₅	b ₂	b ₄	d	d ₂	d ₃	d ₄	r	Maximum allowable load C (N)	Table weight (kg)
TRL1 25	13 ±0.1	30 ±0.2	18.4	8.6	10	4.1	M2	M2	M2.5	9	250	0.03
TRL1 35											350	0.05
TRL1 45											450	0.06
TRL1 55											530	0.08
TRL1 65											650	0.09
TRL1 75											750	0.11
TRL1 85											900	0.12
TRL1 95											1000	0.14
TRL1 105											1150	0.16
TRL2 35	21 ±0.1	40 ±0.2	25	11	15	6	M3	M3	M3	11	425	0.09
TRL2 50											595	0.15
TRL2 65											850	0.19
TRL2 80											1020	0.23
TRL2 95											1275	0.27
TRL2 110											1445	0.31
TRL2 125											1700	0.35
TRL2 140											1870	0.39
TRL2 155											2125	0.43

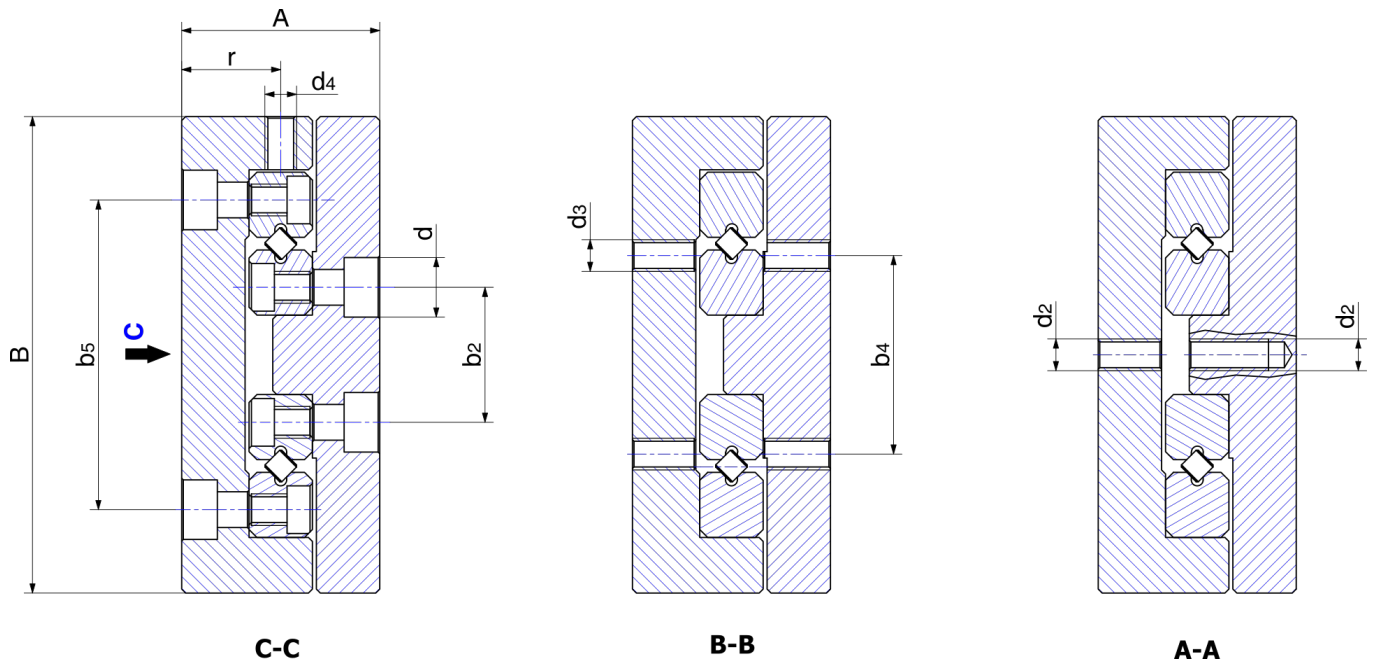

Table designation	A	B	b ₅	b ₂	b ₄	d	d ₂	d ₃	d ₄	r	Maximum allowable load C (N)	Table weight (kg)
TRL3 55	25 ±0,1	60 ±0,2	39	17	25	7.5	M4	M4	M4	12.5	910	0.29
TRL3 80											1300	0.42
TRL3 105											1820	0.55
TRL3 130											2220	0.68
TRL3 155											2730	0.81
TRL3 180											3120	0.94
TRL3 205											3510	1.07
TRL3 230											3770	1.2
TRL3 255											4160	1.33
TRL3 280											4420	1.46
TRL3 305											4820	1.59
TRL6 110	40 ±0,1	100 ±0,2	64	26	50	11	M5	M6	M5	20.5	3710	1.5
TRL6 160											5830	2.25
TRL6 210											7420	3
TRL6 260											9540	3.75
TRL6 310											11660	4.5
TRL6 360											12720	5.25
TRL6 410											14840	6
TRL6 460											16430	6.75
TRL6 510											18020	7.5

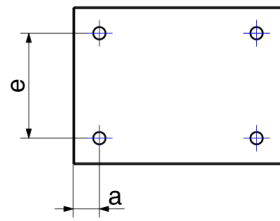
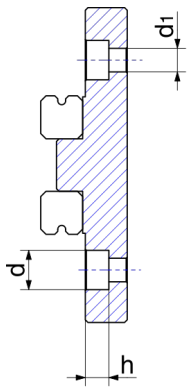

Fig.1

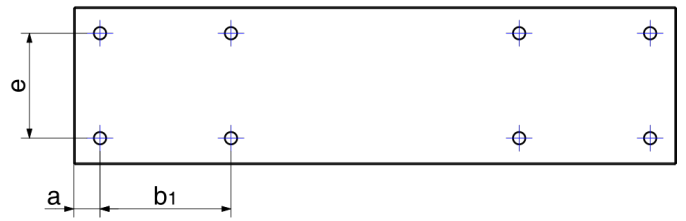

Fig. 2

Matched tables can be supplied with tolerance on A (A-A₁) quote of ± 0.01 mm

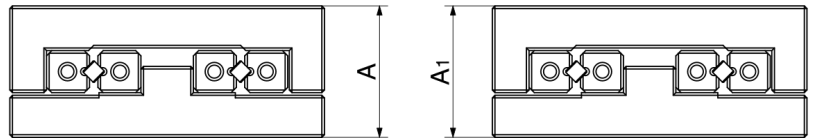

Table designation	a	b ₁	Fig.	e	h	d	d ₁
TRL1 25	3.5	10	1	22	2.5	4.1	2.5
TRL1 35			1				
TRL1 45			1				
TRL1 55			2				
TRL1 65			2				
TRL1 75			2				
TRL1 85			2				
TRL1 95			2				
TRL1 105			2				
TRL2 35			5				
TRL2 50	1						
TRL2 65	1						
TRL2 80	2						
TRL2 95	2						
TRL2 110	2						
TRL2 125	2						
TRL2 140	2						
TRL2 155	2						

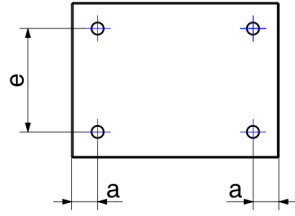
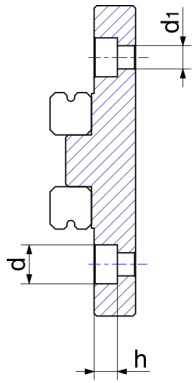

Fig. 1

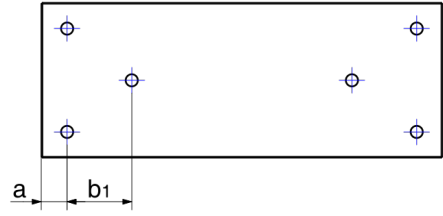

Fig. 3

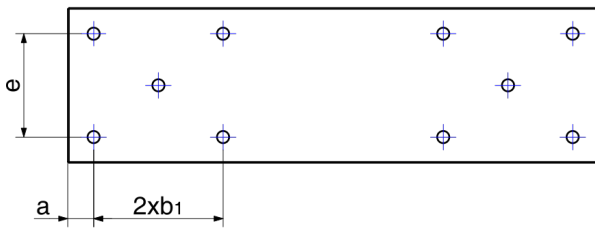

Fig. 4

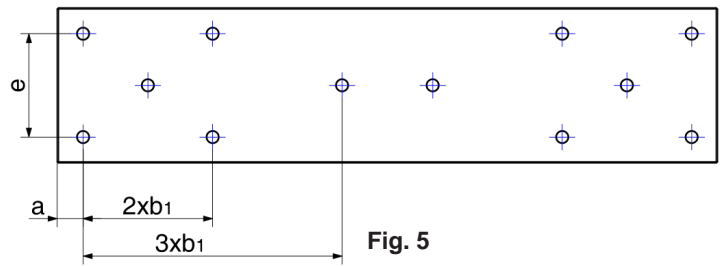

Fig. 5

Matched tables can be supplied with tolerance on A ($A-A_1$) quote of ± 0.01 mm

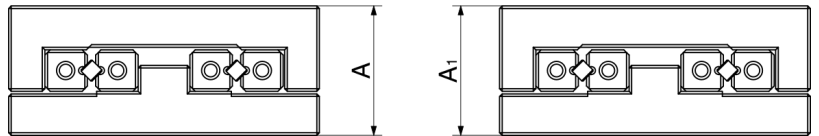
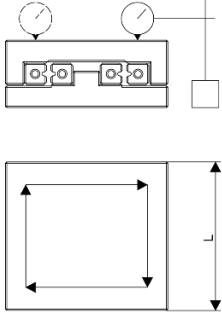
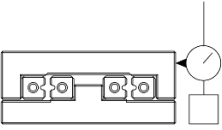
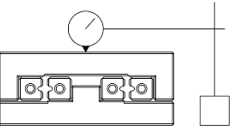
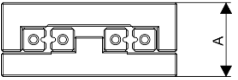

Table designation	a	b ₁	Fig.	e	h	d	d ₁
TRL3 55	10	25	1	40	5	7.5	4.5
TRL3 80			1				
TRL3 105			1				
TRL3 130			1				
TRL3 155			3				
TRL3 180			3				
TRL3 205			4				
TRL3 230			4				
TRL3 255			5				
TRL3 280			5				
TRL3 305			5				
TRL6 110	10	50	1	60	7	11	7
TRL6 160			1				
TRL6 210			3				
TRL6 260			3				
TRL6 310			3				
TRL6 360			3				
TRL6 410			4				
TRL6 460			4				
TRL6 510			5				

Tolerances allowed for tables TRL

Table length (mm) / Tolerance (μm)			from 25 to 50	from 55 to 100	from 110 to 160	from 180 to 310	from 410 to 510
	Flatness checked on longitudinal and transversal axis of the table	Admitted error	10	10	15	20	25
	Parallelism (Lateral)	Admitted error	4	5	6	8	9
	Parallelism (Upper Portion) measured on the center line	Admitted error	2	4	6	8	9
	Height A measure with micrometer	Admitted error	± 100				

Frictionless table TRKD

The tables TRKD are composed of an upper structure made of aluminium alloy which incorporates two recirculating linear ball bearings. This unit rides on a rail type GRD.

Such an assembly allows for long travel distance, limited only by the rail length. The rail GRD was previously described. It is obvious that the performance of the system is directly related to the type of recirculating linear ball bearing employed.

The ratings vary between 850 N and 3300 N and the maximum velocity is 120 m/min.

Max admitted acceleration: 50 m/sec²

It is possible to assemble more translating units on the same rail, their height matching can be requested when ordering.

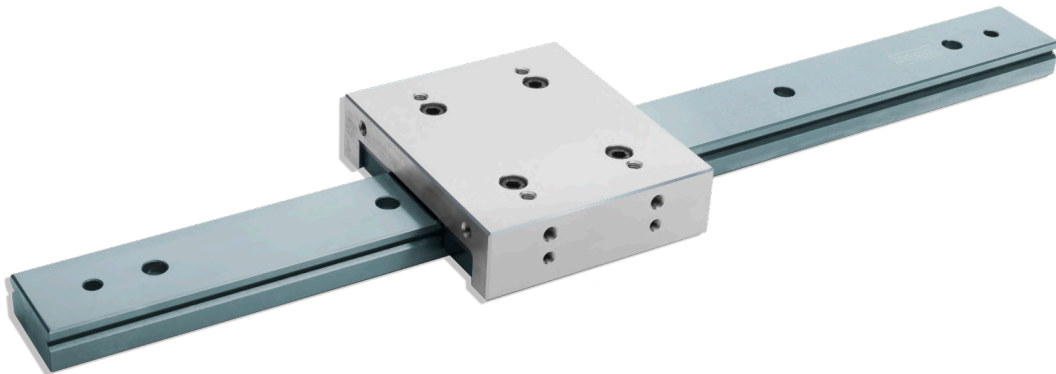

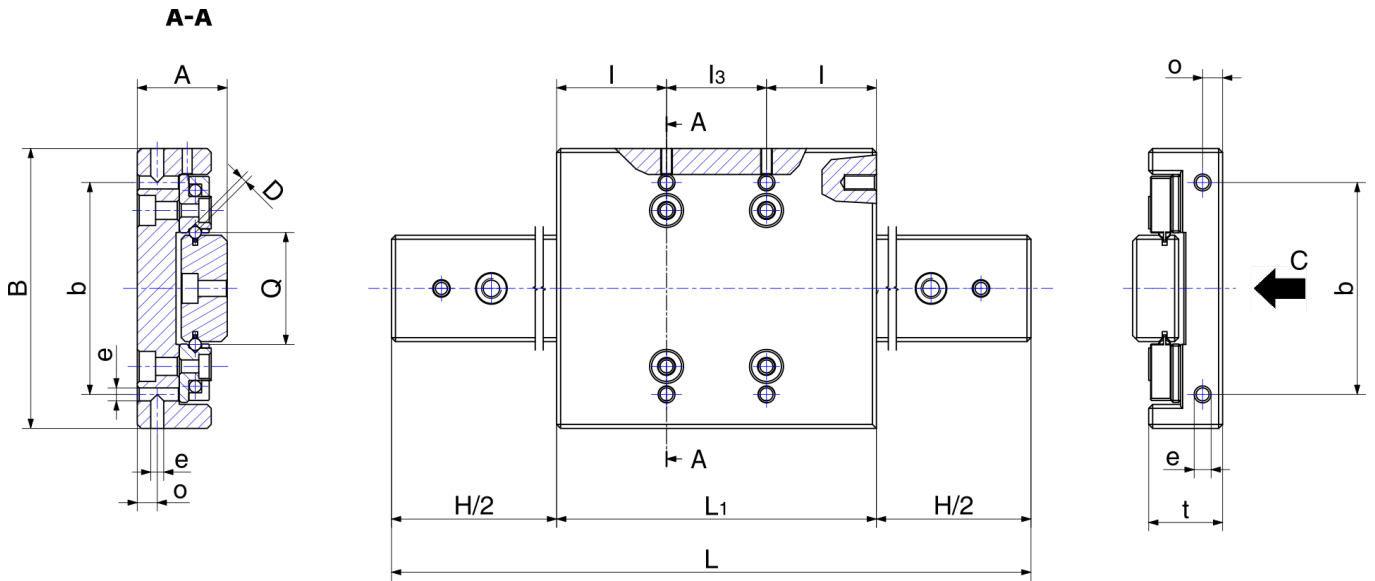
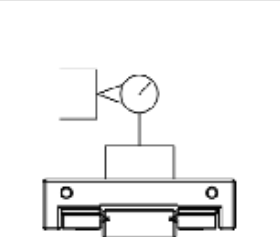
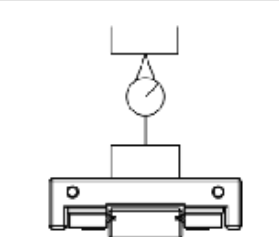
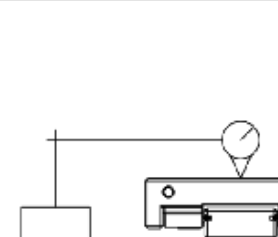

Table type	Stroke H	A	B	L	L_1	Q	D	b	e	l	l_3	o	t	Maximum allowable load C (N)
TRKD3	120	22.5	70	200	80	28	3	53	M4	27.5	25	5	18.5	850
	220			300										
	320			400										
	420			500										
TRKD6	95	36	120	200	105	45	6	86	M6	27.5	50	8	31	1430
	195			300										
	295			400										
	395			500										
	495			600										
	595			700										
	695			800										
	795			900										
895	1000													
TRKD9	145	49	180	300	155	72	9	126	M8	27.5	100	10	43	3300
	245			400										
	345			500										
	445			600										
	545			700										
	645			800										
	745			900										
	845			1000										

Inspection tables for TRKD

Tolerance (μm)				
Designation		Lateral parallelism checked on the entire stroke	Parallelism checked on the entire stroke	Parallelism of upper portion measured on the center line
TRKD3	200	10	4	15
	300	10	5	20
	400	16	7	20
	500	24	7	20
TRKD6	200	10	4	15
	300	10	5	20
	400	18	8	20
	500	24	8	20
	600	10	8	25
	700	15	9	25
	800	18	9	25
	900	24	9	25
	1000	26	10	25
TRKD9	300	10	5	20
	400	10	6	25
	500	10	7	25
	600	10	8	30
	700	12	9	30
	800	12	9	30
	900	14	10	30
	1000	14	10	30

Precision table TV

Linear precision tables, modular type for assembling on X,Y, Z and on multiple axes. Motor drive by CNC control, motion on cross roller rails and ballscrews. Considerable stiffness and load capacity.



Overall dimension

Table designation		Dimensions (mm)															
		A	B	C	D	E	F-G	H	I	L ₁	L ₂	P	d ₁	L ₃	L ₄	d ₂	M
TV00	75/50	52	25	25	75	50	-	6	12	2 x 12.5	20	1 x 50	4.5	25	38	M5	According to the motor type
	125/75			50	125	75				2 x 25		1 x 70		30			
TV0	100/75	75	32	5	100	75	-	6	12	2 x 12.5	32	1 x 75	5.5	50	52	M5	
	150/100			50	150	100				2 x 25		1 x 100		75			
TV01	150/100	100	45	50	150	100	-	6	15	2 x 37.5	50	1 x 75	5.5	50	75	M5	
	200/100			100	200	2 x 62.5											
TV1	125/250	125	50	50	250	125	37.5	6	15	2 x 25	90	4 x 50	5.5	90	100	M5	
	125/300			100	300					2 x 50							
TV2N	C100	210	80	100	420	210	55	8	18	2 x 35	195	7 x 50	6.6	195	150	M6	
	C150			150	470					2 x 60							
	C200			200	520					2 x 85							
TV3N	C100	260	85	100	500	260	70	8	18	2 x 50	240	4 x 100	8.5	240	200	M8	
	C150			150	550					2 x 75							
	C200			200	600					2 x 100							

(C = Stroke)

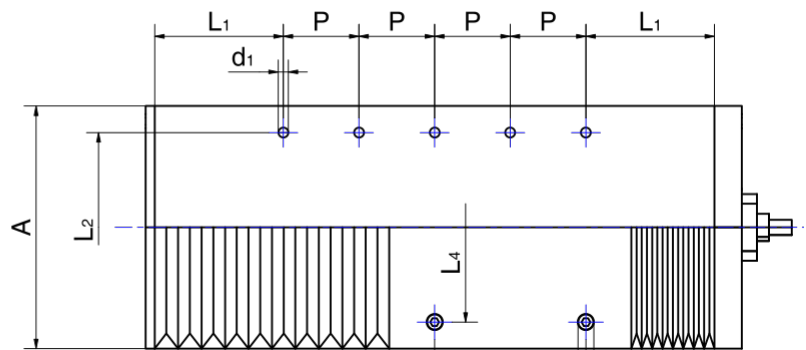
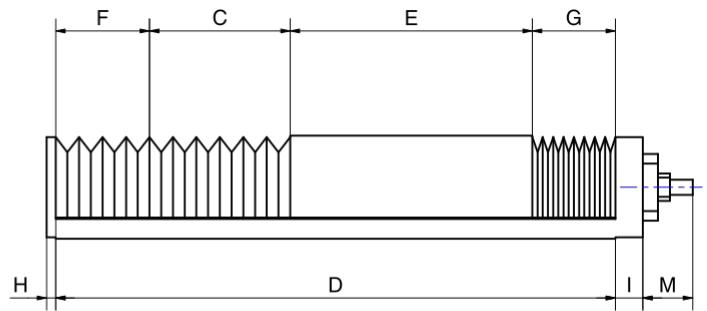
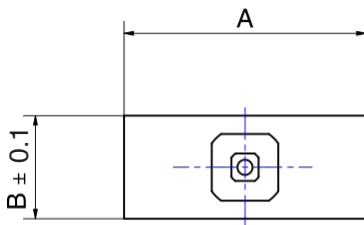
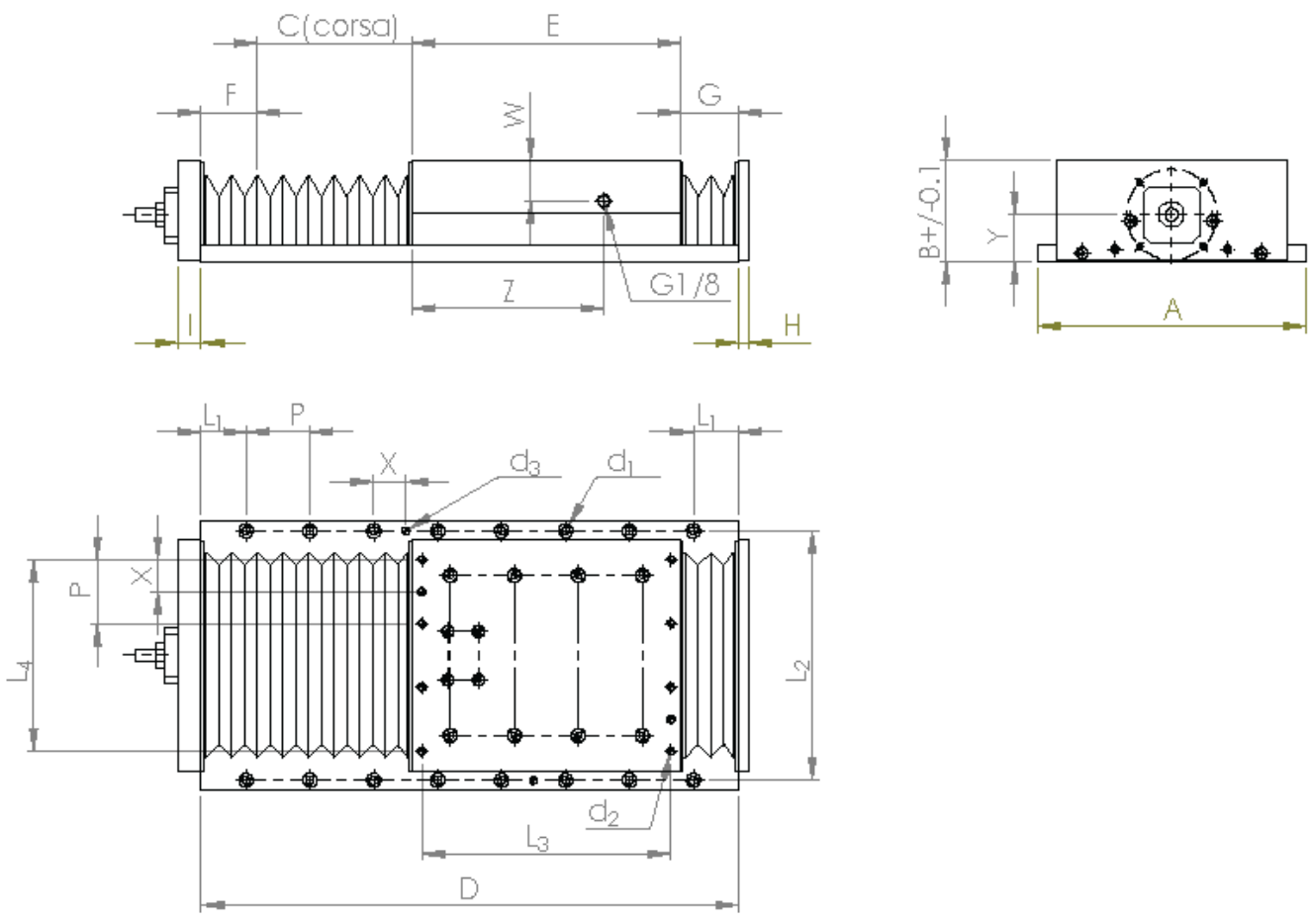

Table type	X	W	Z	Y	d_3
TV2N	25	32	150	37	6 H7
TV3N	50	29	160	41	8 H7



Design features

Table type	Ballscrew		Type of rails utilised		Table structure	Protections
	Type*	Ø x pitch (mm)				
TV00	T	6 x 1	3 mm Ø rollers		Cast-iron with ground surfaces	-
TV0	T-RG	8 x 1				
TV01	T-RG / RDS	8 x 1 / 8 x 2	4.5 mm Ø rollers			
TV1	RDS	10 x 2				
TV2N	RDS	16 x 5	6 mm Ø rollers	Sliding on antifriction material		
TV3N	RDS	20 x 5				

Ballscrew type

- T** precision turning
- T-RG** with precision turning - with play compensation
- RDS-RT** with preloaded recirculating balls and ground thread

On request, screw pitches different from the ones on the chart are available.

Accessories

- Motor joint support
- Emergency limit-switch
- Lubrication system (TV2N-TV3N)

On specific request, can be supplied customized tables, single-axis tables or cross-motion tables.

Motor support mounting

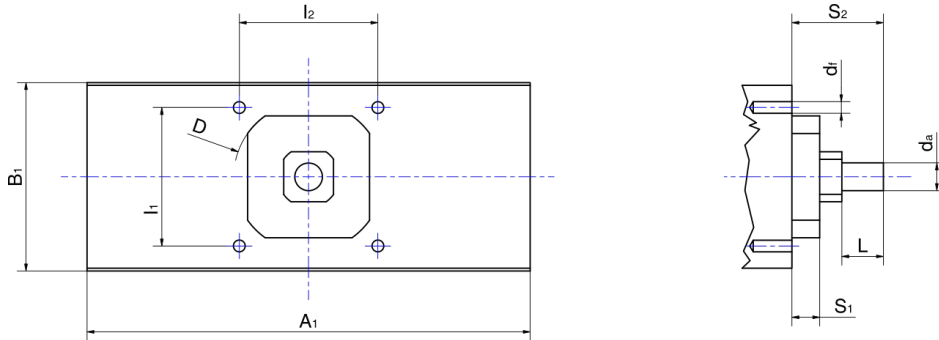

Table designation	A ₁	B ₁	I ₁	I ₂	D	S ₁	S ₂	d _f	d _a	L
TV00	54	24	20	24	22	12	36	M2.5	5	16
TV0	74	31	22	38	35	7	29	M3	6	12
TV01	100	44	35.4	35.4	43	9	27	M3	6	10
TV1	125	48	35.4	35.4	43	9	27	M3	6	10
TV2N	180	78	50	50	54	10	33	M5	10	15
TV3N	220	83	60	60	63	15	49	M6	12	20

Design tolerance (measured on unloads table, located on flat basis)

Table type	Carriage planarity	Value (µm)	Parallelism of lateral carriage motion (*)	Value (µm)	Parallelism of plane carriage motion (*)	Value (µm)
TV00		10		4		4
TV0		10		6		6
TV01		15		8		8
TV1		15		10		10
TV2N		20		12		12
TV3N		25		12		12

(*) Values measured over the total table travel.

Admissible loads and torques

The tables of the TV series are used for the realisation of positioning systems, for general use in the industrial automation and for light mechanical operations.

The admissible loads shown in the charts must be considered as maximum theoretical values both for the rails system and for the thrust load on the drive-screw. For a correct use of the tables as to accuracy, stiffness, lifetime and safety of the system, it is necessary to consider the appropriate safety coefficients. For this purpose, see the charts and calculation methods in the specific chapters in the Rosa Sistemi catalogues for rails and drivescrews.

Ballscrews - features and admissible loads

Note: On the TV2N - TV3N tables, the ballscrews are supported on both ends, while on the others these are supported and linked only to the motor side.

Table type	Screw type	Diameter x pitch (mm)	Admissible load (N)		Axial play (µm)	Accuracy grade (µm)	Mech. repeatable accuracy (µm)
			Stat. load	Dyn. load			
TV00	T	6 x 1	50	20	20	IT 7	20
TV0	T-RG	8 x 1	120	50	0		10
TV01	T-RG	8 x 1	1300	700	0 (light preload)	IT 5 (e/300=23)	5
	RDS	8 x 2	1500	900			
TV1	RDS	10 x 2	2900	1500			
TV2N	RDS	16 x 5	18570	13680			
TV3N	RDS	20 x 5	22390	15080			

Speed

Although the maximum admissible speed for the tables is up to 40-50 m/min, these values will never be reached considering the short stroke of the tables, the necessary accelerations and the reduced pitch of the ballscrews.

From the speed standpoint the limitation is given by the ballscrew, from which the admissible values are derived.

Maximum rotary velocity of the ballscrew (n) 2400 n/min

Screw pitch (p) in mm

Linear table speed obtainable = $\frac{n \times p}{60}$ (mm/sec)

Lubrication

The ballscrews and rails have been correctly lubricated during assembling, i.e. oil is used for the rails and grease for the ballscrews. However, the conditions of the system lubrication must be checked from time to time and, if necessary, the initial conditions restored.

The TV2N/TV3N tables permit the installation of centralised oil lubrication systems.

The tables are supplied together with the specific documentation about the recommended lubricants.

Applicable loads

Table designation		Admissible load (N)	
		FV=FL	
		Static	Dynamic
TV00	75/50	1040	620
	125/75	1560	930
TV0	100/75	1560	930
	150/100	2340	1400
TV01		10200	6100
TV1		13600	8150
TV2N		32667	19067
TV3N		60000	35000

Applicable torques

Table designation		Admissible torques (Nm)			
		MT		ML=MR	
		Static	Dynamic	Static	Dynamic
TV00	75/50	26	15	11	6.5
	125/75	39	23	18	11
TV0	100/75	70	42	18	11
	150/100	15	63	23	13.5
TV01		612	367	143	86
TV1		1020	612	187	112
TV2N		1796	1077	588	352
TV3N		3900	2337	1500	900

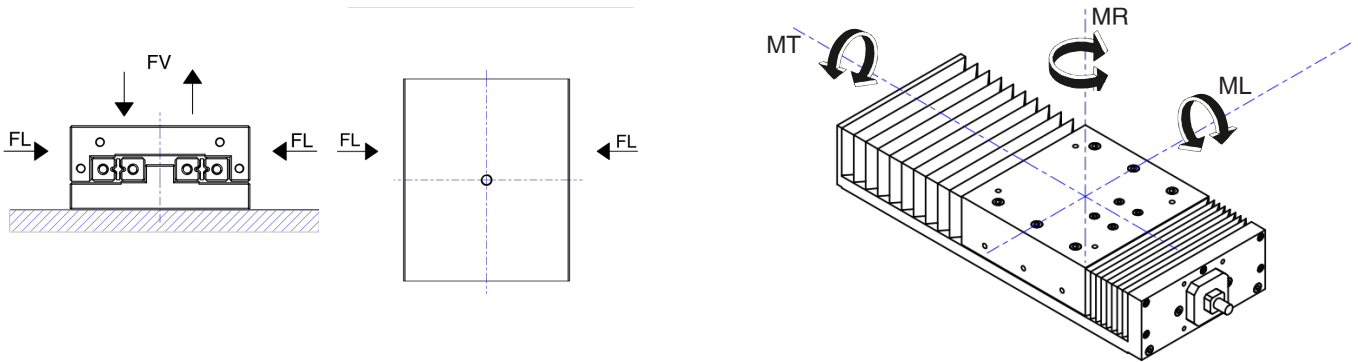

Weight of tables

Total weight of the frame structure
(Accessories and motor not included)

Table designation		Weight (kg)
TV00	75/50	0.6
	125/75	1.1
TV0	100/75	1.5
	150/100	2.2

Table designation		Weight (kg)
TV01	150/100	3.8
	200/100	4.2
TV1	125/250	5.2
	125/300	6.0

Table designation		Weight (kg)
TV2N	C100	26.5
	C150	28
	C200	29.5
TV3N	C100	47
	C150	50
	C200	53

Rosa Sistemi S.r.l.
Via Salvatore Quasimodo 22/24
IT - 20025 Legnano (MI)

www.rosa-sistemi.it

Rosa GmbH
Lippermattstrasse 2
CH - 4710 Balsthal
www.rosa-schweiz.ch

Rosa do Brasil
Rua Dr. Luís Arrobas Martins, 486
BRA - 04781-001 São Paulo

www.rosabrasil.com.br

