





























# Linear guide systems







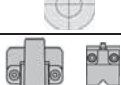





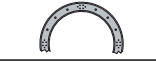
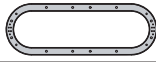







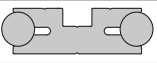

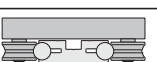

# Summary

<b>Heavy-Line</b>	<b>Guide rails GU..M, GU..MT</b>
	<b>Guide Rollers RKU</b>
	<b>Guide Wheels FKU</b>
	<b>Floating Guide Rollers RKUL</b>
	<b>Lubricator LUBU</b>
	<b>Guide pins SAG</b>
	<b>Guide rails GP..MC</b>
	<b>Ground guide rails GP..M</b>
	<b>Guide Rollers PK</b>
	<b>Guide Wheels FK</b>
	<b>Guide Rollers GC</b>
	<b>Cam followers FG (needle) and FGU (roller)</b>
	<b>Lubricator LUBP</b>
<b>Rolbloc</b>	<b>Guide rails GU..M, GU. .MT</b>
	<b>Carriages ROLBLOC MBL</b>
	<b>Carriages ROLBLOC BL</b>
	<b>Adjustment plates PR</b>
<b>V-Line</b>	<b>Sand blasted guide rails FS..MT</b>
	<b>Ground guide rails FS..M</b>
	<b>Sand blasted guide rails FSH..MT, FSX..MT</b>
	<b>Ground guide rails FSH..M, FSX..M</b>
	<b>Guide Rollers FR..EU</b>
	<b>Guide Rollers FR..EU AS, FR..EU AZ</b>
	<b>Guide Rollers FRN..EI</b>
	<b>Guide Rollers RKY, RKX</b>
	<b>Guide Rollers FKY, FKX</b>
	<b>Floating Guide Rollers FRL..EU</b>
	<b>Floating Guide Rollers RKXL, RKYL</b>
	<b>Spacers FS and FSH</b>
	<b>Lubricator LUBY - LUBX</b>

	20	<b>For medium-heavy loads</b>
	21	
	22	
	23	
	24	
	25	
	28	<b>For medium-heavy loads Dirty environment</b>
	29	
	30	
	31	
	32-33	
	34-35	
	36	
	41	<b>For medium-heavy loads Dirty environment</b>
	42	
	43	
	44	
	48	<b>For medium-heavy loads</b>
	49	
	50	
	51	
	52	
	53	
	54	
	55	
	56	
	57	
	58	
	59	
	60-61	







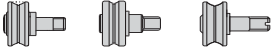

# Summary

<b>Multi-Motion-Line</b>	<b>Circular rails FSR..M</b>	
	<b>Oval circuit FSRO</b>	
	<b>Ring circuit FSRQ</b>	
	<b>Steering carriages T4R...</b>	
<b>C-Line</b>	<b>Guide Rails LS</b>	
	<b>Guide Rollers RCS</b>	
	<b>Guide Rollers RAS</b>	
	<b>Carriages C3 RCS, C3 RAS, C3 RYS</b>	
	<b>Carriages C4 RCS, C4 RAS, C4 RYS</b>	
	<b>Carriages C5 RCS, C5 RAS, C5 RYS</b>	
<b>Base-Line</b>	<b>Guide rails DC</b>	
	<b>Guide rails C</b>	
	<b>Guide Rollers PFV</b>	
	<b>Guide Rollers RKO</b>	
	<b>Carriages T4PFV</b>	
	<b>Wipers NAID</b>	
	<b>Lubricator LUBC</b>	
	<b>Guide rails FWS</b>	
	<b>Guide rails FWH</b>	
	<b>Guide Rollers FR..EU</b>	
	<b>Guide Rollers FR..EU AS, FR..EU AZ</b>	
	<b>Floating Guide Rollers FRL..EU</b>	
	<b>Carriages T4FR</b>	
	<b>Flexi-Line 645</b>	<b>Guide rails FWN</b>
		<b>Carriages TA4, TB4</b>

	67	<b>For all applications</b>
	69	
	70	
	71	
	78	<b>For light-medium loads</b>
	79	
	80	
	81	
	82	
	83	
	87	<b>For medium loads Aggressive environment</b>
	88	
	89	
	90	
	91	
	92	
	93	
	96	
	97	<b>For light-medium loads</b>
	98	
	99	
	100	
	101	
	105	<b>For light-medium loads</b>
	106-107	

# Summary

<b>U-Line</b>	<b>Guide rails LM</b>
	<b>Guide Rollers RCL, RCP, PFV</b>
	<b>Floating Guide Rollers RAL</b>
	<b>Guide Wheels GLA</b>
	<b>Carriages C3RCL, C3RAL, C3RYL</b>
	<b>Carriages C4RCL, C4RAL, C4RYL</b>
	<b>Carriages T4RCL, T4RCP, T4PFV, T4RAL, T4RYL</b>
	<b>Lubricator LUBM</b>
	<b>Guide rails LML 20</b>

	<b>112</b>	<b>For light-medium loads</b>
	<b>113</b>	
	<b>114</b>	
	<b>115</b>	
	<b>116</b>	
	<b>116</b>	
	<b>117</b>	
	<b>117</b>	
	<b>119</b>	

# Technical features

## Nadella linear systems

With this line of products, NADELLA confirms the aim to provide manufacturing solutions tailored to the user's needs in order to achieve simple automation at a low cost.

The process under way of transferring production automation and relevant handling onto increasingly heavier and cumbersome units has prompted us to seek original and flexible components for the different commodity sectors.

We have accumulated sound working experience in the following sectors:

- marble-working machinery
- foundry machinery
- metal sheet working machinery
- special lifting machines
- pick up
- automatic warehouses
- textile machines
- machine tool protections and utilities
- oxygen cutting machines

Our Technical Department works with Customers and recommends the best component choice by making the calculations needed to determine the best life.

### Guides

#### Length

The maximum length of each single guide component is shown on the dimensional tables.

The standard lengths of the rails are determined by adding the product of the fixing hole centre distance and the number of holes to twice the end dimension (see dimensional tables).

Length	≥ 150 < 420	≥ 420 < 1.050	≥ 1.050 < 2.040	≥ 2.040 < 4.020	≥ 4.020 < 5.280
Length tolerance	± 0,5	± 0,8	± 1,2	± 2	± 2,5

#### Joints

For strokes of greater length, the guide components can be joined after grinding the end faces (suffix R or RR). To maintain the hole centre distance tolerance, when ordering always specify the number of individual rails making one continuous length.

Please specify in the order when rails have to be matched. The junctions are marked (letters and numbers) to avoid a mix-up of different rails.

#### Fixing holes

The guides are available with standard holes, as shown in dimensional tables, with special hole layout or without holes (see order code referencing) Standard tolerance for hole position is ± 0,25 mm.

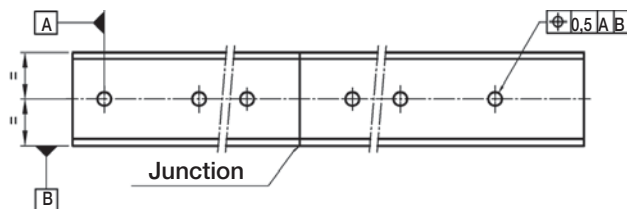

The standard boring layout is designed to fit most common application requirements, but connection strength has to be evaluated on the application case.

### Steel guides

#### General

Steel rails are made of bearing steel to give best stability and durability. Raceways are induction hardened to achieve 58 HRC hardness minimum. The rail core remains soft to allow easy machining.

Rails can be provided with different finishes to meet specific application requirements.

**Guide rails MT type.** Profile is produced by cold drawing process, raceways are induction hardened and sandblasted to improve surface strength and finish.

**Guide rails M type.** Profile is usually produced by cold drawing process, induction hardened on raceways and ground to improve surface finish and profile geometry and to remove the partially decarburised surface (0.1 mm max on cold drawn rails ..MT). Ground rails have to be used when there are high loads, heavy-duty cycles or when there is a high accuracy requirement.

**Guide rails MC type** (flat rail GP.MC only). MC rails are induction-hardened on every side and finished by-a-rough grinding.

#### Options

##### Corrosion protection

For use in oxidising environments or in the presence of corrosive agents, the guides are available with chemical nickel-plating protective anticorrosion treatment (suffix NW.).

This treatment features substantial mechanical characteristics together with a resistance to salty mist corrosion superior to that of hard chrome. On request many rails are available in stainless-steel version (suffix NX)

##### Circular rail

On request circular rails can be provided. Circular rails can be used as an alternative to rotating devices or as junction between straight rails.

#### Technical features

Standard rail straightness (for non-mounted rails) is 0.5 mm/m max. Higher accuracy can be supplied on request.

# Technical features

## Temperature

Standard operating temperature range is  $-20^{\circ}\text{C}$  up to  $150^{\circ}\text{C}$ . In lower or higher temperature applications please contact Nadella Technical Service. Special care is required if guide rollers are operating at maximum temperature.

## Aluminium guides

### General

Made by joining an aluminium alloy support element and hardened steel rods that form the sliding surfaces.

The best features of the two materials and relevant working technologies are combined to give the lightness of the alloy and the hardness and surface finish of the rods.

Guides of this type can be used for structural functions; they have a high moment of inertia that enables them to be used in many applications as carrying structures.

Aluminium extruded profiles are stabilised and anodised. Sliding rods are induction hardened and ground.

### Options

#### Corrosion protection

For use in oxidising environments or in the presence of corrosive agents, the guides of this series can feature stainless-steel bars (suffix NX).

#### Chromium-plated rods

Optional chromium-plated rods are available (suffix CH); the thickness of the chromium plating is  $10 \pm 5 \mu\text{m}$  with hardness  $\geq 800 \text{ HV}$ .

Please check option availability in dimensional tables.

### Joints

In case rail made by multiple C-DC or LM rails the most efficient joint can be realized with the insertion of a dowel pin inside the rods. This solution allows for simple assembly at the site and maintains alignment under load.

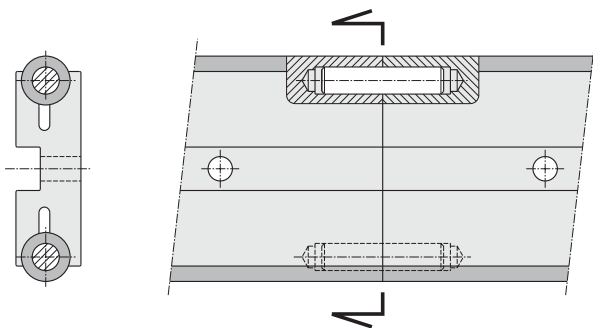

For rails FWS the joint can be realised by protruding the rods of one rail in order to engage them in the profile of the next rail. In the final configuration there will be a small gap between the aluminium profiles (see next drawing).

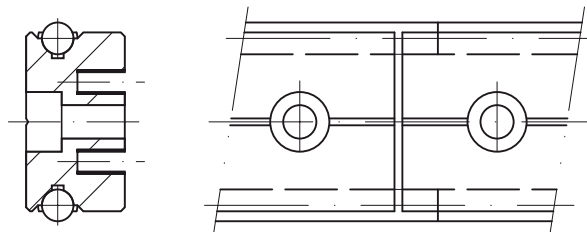

### Technical features

Standard rails straightness (for non mounted rails) is  $0.5 \text{ mm/m}$  maximum. Higher accuracy can be supplied on request.

### Temperature

Standard operating temperature range is  $-20^{\circ}\text{C}$  up to  $70^{\circ}\text{C}$ . Applications with frequent temperature variation should be avoided. For operating conditions outside the given range please contact Nadella Technical Service.

## Guide rollers

### General

Nadella provide a wide range of guide rollers to be able to meet different technical and economic requirements. All guide rollers are produced in concentric and eccentric versions to allow backlash adjustment during assembly on final equipment. Eccentric rollers are identified by additional R in the code.

The sides of the races of the guide roller are slightly convex. Besides reducing rolling friction, this also permits offsetting slight guide flexing or small assembly alignment errors.

Guide rollers are fitted with seals or shields for bearing protection and lubricant retention as described in dimensional tables.

Guide rollers based on **needle or tapered roller bearings** (FRN..EI,RK..,PK..) are recommended for critical applications with heavy axial loads and/or shock loading. Guide rollers based on **ball bearings** (FR..EU, PFV, RCL) are more suitable for lighter loads or high dynamic systems.

The carriages based on Rolbloc's system are recommended for applications with heavy loads, high frequency of work and aggressive environment (dust, abrasive).

When mounting guide rails opposite to each other with connected carriages, as shown in the next sketch, a high level of parallelism between the guide rails is required when axially rigid rollers are used.

To avoid operating problems it is recommended to use axial rigid fixed rollers on one carriage e.g. FR..EU/FRR...EU and axial movable rollers on the other

# Technical features

carriage e.g. FRL..EU/FRLR..EU

Movable rollers allow a little misalignment between the opposite mounted guide rails.

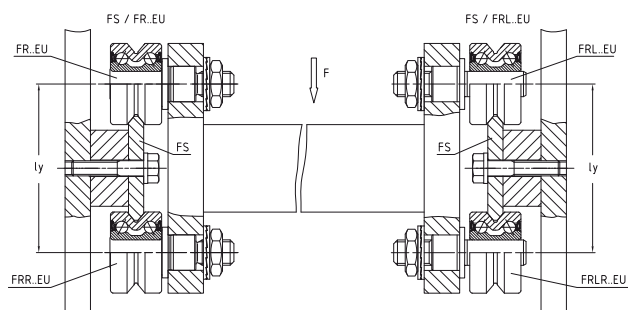

Another solution is to use one profiled guide rail e.g. FS and on the opposite side a flat rail e.g. GP in connection with rollers GC or PK.

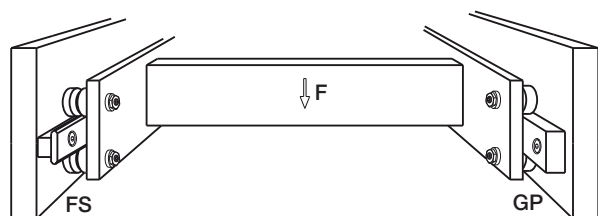

## Technical features

### Lubrication

Guide roller FRN..EI permits bearing relubrication. All other guide rollers are long life lubricated.

### Temperature

Guide roller should not operate at constant temperature above 80°C. For short durations 100°C can be accepted. For higher temperature please see the "option section".

### Speed limit

Max velocity has to be determined for each application relevant to the guide roller type, size and load conditions. As general value, in normal conditions maximum speed is 4 m/sec but, with the correct choice of the components, the speed can reach 10 m/s. Contact Nadella Technical service in case of specific request.

## Options

### Corrosion protection

For uses in oxidising environments or in the presence of corrosive agents, the guide rollers are available in stainless steel (suffix NX) the guide rollers with tapered rollers (RKU, RKY/X, FKU, FKY/X) and needles (FRN) are equipped with standard bearings. Check in the dimensional table component availability.

### High temperature

On request guide rollers can be equipped with Viton seals to operate at temperature up to 120° (suffix V). Check in the dimensional table component availability.

## Accessories

### Tables and carriages

Standard table and carriages for C-DC and LM systems incorporate a black anodised aluminium plate fitted with guide rollers.

### Wipers

Standard wipers NAID for C-DC rails are made from NBR compound moulded on a steel plate.

### Lubricators

Are composed by two main parts: a plastic box with the same shape profile of the rail, and a lubricated felt; the felt is slightly pressed on the raceways by a spring. The plastic box, that drags the raceways, works as a wiper, and remove dust and shavings.

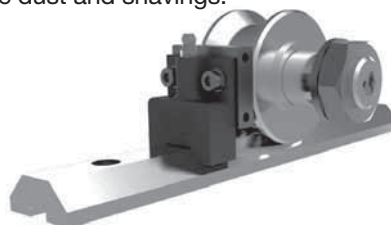

The plastic box can be mounted directly on the guide rollers plate by the appropriate aluminium plate included in the kit.

In the lubricators for guide rollers size 52 or higher, the grease nipple allows an easy connection with a re-lubrication system.

For the simply lubrication of the rails you can use one lubricator only on each raceway; in order to wipe the raceways it is better to mount two lubricators, before and after the carriage.

The lubricators are supplied with the felt already lubricated.

### Use in dirty environment

Due to the design cam rollers with profile are especially adapted to the use in rough and dirty environment. This properly has proved true in many applications such as welding plants, steel and grinding machines and is superior to recirculating ball bearing guides in continuous operation.



# Technical features

## Lubrication

### Bearing lubrication

All the guide rollers, except for the FRN..EI, based on needle bearings, are equipped with long life lubricated bearings. This means that the grease inside the bearing is enough for the entire life of the roller guide. The roller guide type FRN..EI, with needle bearings, accommodates the re-lubrication of the bearings.

### Rail lubrication

Rails must be lubricated. This allows reducing the friction, to reach the calculated lifetime of the system and to work at high speed.

No or insufficient lubrication will cause rapid deterioration. The typical signal of tribocorrosion is the presence of a red/dark oxide and rapid wearing of the rail and guide rollers.

The lubrication of the rail, the working environment and the load must be considered all together for a correct estimation of the lifetime of the guide system.

Generally speaking, for application with low duty frequency, a periodic relubrication with a grease or with a viscous oil will sufficiently maintain the lubrication film. The re-lubrication interval depends on the application and must always be tested in the real working conditions. In a system with ground rails and short stroke without lubricators, you can consider a re-lubrication interval every 100,000 cycles. Increasing the load, speed or stroke, or using an under sized bearing will increase lubrication demand and result in a shorter lubrication interval. For a constant lubrication we suggest the use of felt lubricators to ensure a constant layer of lubricant between guide rollers and raceways. Felt lubricators enlarge the lubrication interval more than ten times.

The recommended lubricants are greases and oil for bearings, linear rails or chains, with a high viscosity of the basic oil and with EP additives, in order to separate the metallic surfaces even with low speed.

## Assembly instructions

### Guide rollers

The eccentric guide rollers allows the preload or clearance of the carriage to be adjusted independently of the guide roller mounting hole positioning tolerance or the distance between the rails.

Recommended mounting hole tolerance is H7.

When adjusting the eccentric guide roller care has to be taken to avoid excessive preload. Excessive preload can reduce the life of the linear system.

Set the preload turning the guide roller counterclockwise

so that any movement caused by vibration will cause the nut to be tightened. Ensure the preload is not increased when tightening the nut.

A simple way of setting a roller preload is as follows:

- 1 move the slider on the guide, holding the roller being adjusted with two fingers to prevent it from rotating
- 2 increase the preload by means of the wrench
- 3 repeat step 1 making sure the roller slides without rolling
- 4 when it is no longer possible to prevent roller rolling, slightly decrease the preload and fully tighten the lock nut, thereby setting the position of the eccentric.

When correctly adjusted it is just possible to cause the guide roller to slip on the guide rail when a torque is applied to the roller.

### Guides

For single guide rail type FS, FWS, DC and LM no special assembly instructions are necessary. For multiple parallel rails parallelism has to be checked to avoid guide rollers overload or excessive carriage play. When constant preload is required parallelism error has to be lower than 0.050 mm.

Connection between the rail and the mounting surface has to be designed accordingly with the operating condition to ensure proper product positioning and functionality.

The direction and intensity of the load, the number and strength of the screws, the geometry of mounting surfaces, use of pins or wedges have to be evaluated to fully utilize the linear guide load capacity.

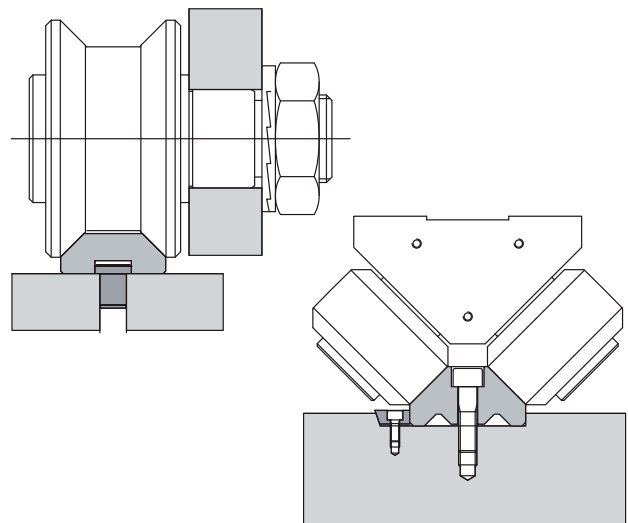

### Carriages

Carriages are supplied with concentric guide rollers nut tighten already. Eccentric guide rollers have to be set and tighten during final assembly operation by customer.

# Technical features

## Calculation procedure

Calculation is carried out in two steps, first defining the forces on the most heavily loaded roller and then estimating the safety factors and life.

## Calculating the loads on the guide rollers

In the case of complex load situations, with forces acting in different directions, calculating the reactions on the rollers is difficult and hard to simplify.

In the event of the applied load having a direction parallel to one of the co-ordinate axes, the radial  $P_r$  and axial  $P_a$  components of the reactions on the most loaded roller can be obtained using elementary formulas.

With reference to the diagrams shown, we obtain the load components on the rollers relevant for checking and calculating the life, applying the following methods.

Angle  $\alpha$  in the formulas is half the groove angle. Look in the dimensional table notes for the correct value.

Distance  $l_c$  is the effective contact distance. With the exception of ROLBLOC system the correct value is calculated as the guide rollers centre distance across the rail plus or minus the outer guide roller diameter  $D_e$ , depending if the guide is outside or between the rollers.

Guide between the rollers

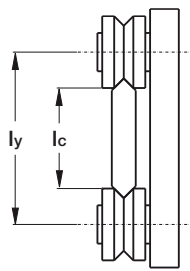

$$l_c = l_y - D_e$$

Guides outside the rollers

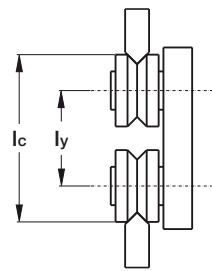

$$l_c = l_y + D_e$$

In case of ROLBLOC the distance  $l_c$  is the distance between the rails basis.

Guides between the rollers

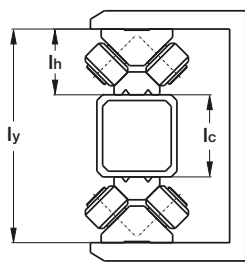

$$l_c = l_y - 2 \cdot h$$

Guides outside the rollers

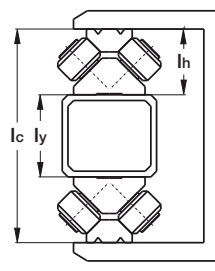

$$l_c = l_y + 2 \cdot h$$

Diagram a)  
load F applied parallel to axis Y

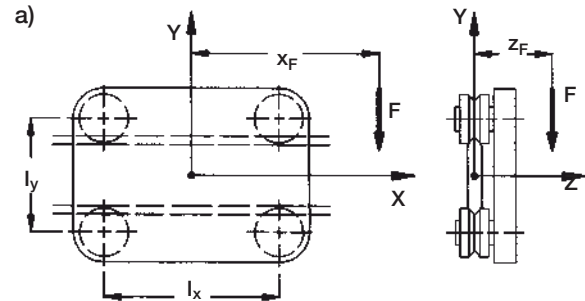

$$P_a = \frac{F \cdot z_F}{2 \cdot l_c}$$

$$P_r = \frac{F \cdot (l_x + 2 \cdot x_F)}{2 \cdot l_x} + \frac{F \cdot z_F \cdot \tan \alpha}{2 \cdot l_c}$$

Diagram b)  
load F applied parallel to axis Z

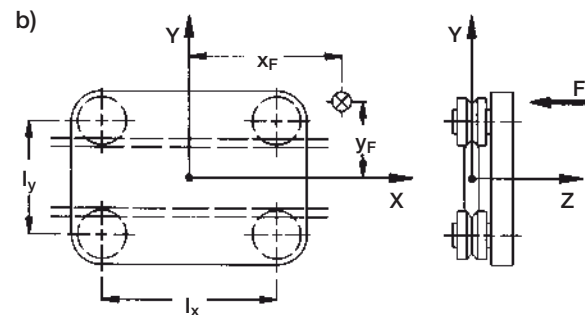

$$P_a = \frac{F}{4} + \frac{F \cdot x_F}{2 \cdot l_x} + \frac{F \cdot y_F}{2 \cdot l_c}$$

$$P_r = P_a \cdot \tan \alpha$$

Diagram c) load F applied parallel to axis X

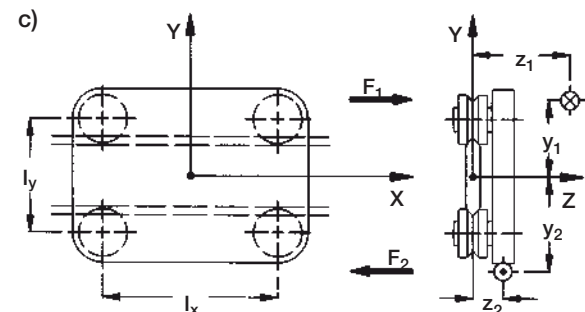

# Technical features

In this case the external load  $F_1$ , applied at the point of co-ordinate  $y_1 z_1$ , should be considered together with reaction  $F_2 = -F_1$ , applied at the point of co-ordinate  $y_2 z_2$ . Calling  $\Delta y$  the absolute value of  $y_2 - y_1$  and  $\Delta z$  the absolute value of  $z_2 - z_1$ , the following formula is used:

$$P_a = \frac{F_1 \cdot \Delta z}{2 \cdot l_x}$$

$$P_r = \frac{F_1}{l_x} \cdot \left( \frac{\Delta z \tan \alpha}{2} + \Delta y \right)$$

## Guide roller calculation

In the table for each roller the following data is specified:

$C_w$  basic dynamic load, it is the radial load [N] that applied to the guide roller gives 100 km nominal life\*.

$F_r$  limit radial load, it is the maximum radial load [N] that can be applied on the guide roller; for the guide wheels is the limit radial load of the wheel.

$F_a$  limit axial load, it is the maximum axial load [N] that can be applied on the guide roller; for the guide wheels is the limit axial load of the wheel.

X and Y coefficients to define the equivalent load for bearing life.

$\alpha$  is the contact angle dependent on the guide roller type.

Rollers FRN..EI work as combined bearings, the basic dynamic load is defined as:

$C_{wr}$  basic radial dynamic load, it is the radial load [N] that applied to the guide roller gives 100 km nominal life\*.

$C_{wa}$  basic axial dynamic load, it is the axial load [N] that applied to the guide roller gives 100 km nominal life\*.

**Note\*:** ISO 281 states 'the nominal life will be exceeded by 90% of bearings before the first sign of material fatigue'.

## Nominal life calculation

System life is the minimum life of either the bearings in the guide roller or the rail/roller contact surfaces.

For the rail/roller surface see the lubrication paragraph. For the bearings life proceed as follows.

The loads  $P_r$  and  $P_a$  are calculated for ideal condition. However, in practice, because of the structure and operating conditions a better calculation and life

estimation is performed using overload factor  $f_w$  as follows:

- 1.0 – 1.2 smooth operation at low speed at constant load without shocks
- 1.2 – 1.5 smooth operation with load variation
- 1.5 – 2.0 operation with small shocks and vibrations
- 2.0 ~ 4.0 high acceleration, shocks and vibrations

Once  $P_a$  and  $P_r$  has been defined we can proceed to calculate the equivalent load  $P_{eq}$  (not for FRN..EI).

$$P_{eq} = X P_r + Y P_a \quad [N]$$

Coefficients X and Y can be obtained from guide rollers tables.

In case of pure radial guide roller as PK and GC or floating bearings FRL, RAL, RKXL, RKUL.

$$P_{eq} = P_r \quad [N]$$

Nominal bearing life:

$$L_{10} = 100 \left( \frac{C_w}{P_{eq} \cdot f_w} \right)^p \quad [km]$$

Where coefficient p is:

$p = 3$  for ball bearing guide rollers  
(FR..EU, RCL.., PFV.., RAL, MBL)

$p = 10/3$  for roller bearing guide rollers  
(PK.., RKY, RKX, ROLBLOC, GC, FRL..)

**In case of guide rollers based on needle bearings type FRN..EI** nominal bearing life is calculated as the minimum between:

$$L_{10} = 100 \left( \frac{C_{wr}}{P_r \cdot f_w} \right)^{10/3} \quad [km]$$

and

$$L_{10} = 100 \left( \frac{C_{wa}}{P_a \cdot f_w} \right)^{10/3} \quad [km]$$

## Checking the guide roller max load

The values of the radial limit loads  $F_r$  and axial limit loads  $F_a$  shown in the catalogue refer to extreme operating conditions, meaning:

- $P_a = 0$  (pure radial load)
- $P_r = P_a \tan \alpha$  (maximum axial load)

# Technical features

In intermediate cases, when the ratio is included between the extreme values, the equivalent limit load  $F_k$  to be considered must be calculated according to ratio  $k = P_a/P_r$ .

$$F_k = \frac{F_r \cdot F_a}{k \cdot F_r + (1 - k \tan \alpha) \cdot F_a} \quad [\text{N}]$$

To check the strength of the guide roller, in relation to the limit load, the safety factor has to be greater than 1

$$F_k/P_r > 1$$

**Note:** in the following common cases it is not necessary to calculate  $F_k$  and the evaluation can be completed easily. Rollers that allow axial movement (FRL, PK, RKYL, RKUL, GC) don't support axial loads.

In case of loads acting in the guide roller plane ( $F_x$  or  $F_y$  acting with  $Z=0$ ) the axial load is also zero (0) (see calculation example n° 3). In these cases it has to be

$$F_r/P_r > 1$$

In case of load  $F_z$  acting perpendicular at guide roller plane the axial load is maximum (example n° 4).

$$F_a/P_a > 1$$

## Examples of calculation

### 1) A fork-lift truck featuring vertical movement (scheme 1).

The resulting magnitude of the weight passes through point 1, while the vertical force that balances this, for instance the traction of a timing belt, passes through point 2.

Guide rollers type RKY 52 are used with guide rail type FS 62 MT

overload factor  $f_w = 1,0$   
 center distance  $l_x = 300 \text{ mm}$   $l_y = 144,3 \text{ mm}$   
 $F = 1800 \text{ N}$   $z_1 = 100 \text{ mm}$   $y_1 = -150 \text{ mm}$   
 $z_2 = -250 \text{ mm}$   $y_2 = 350 \text{ mm}$   
 $\Delta_z = 350 \text{ mm}$   $\Delta_y = 500 \text{ mm}$

scheme 1

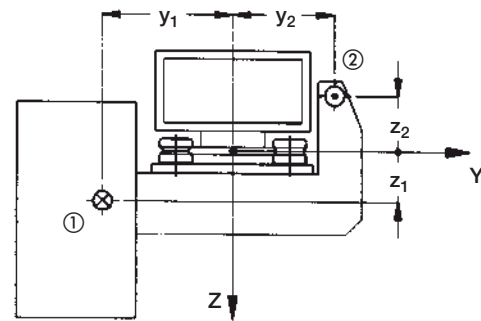
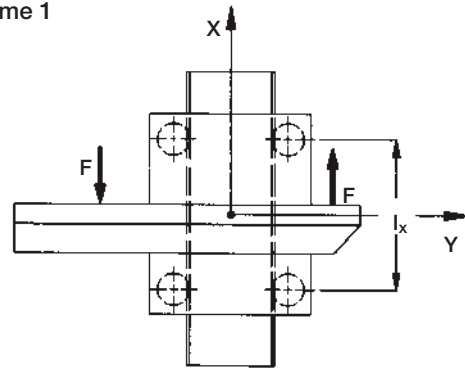

### Load on rollers

$$P_a = \frac{1800 \cdot 350}{2 \cdot 300} = 1050 \text{ N}$$

$$P_r = \frac{1800}{300} \cdot \left( \frac{350 \tan 40}{2} + 500 \right) = 3881 \text{ N}$$

### Nominal life

$$X = 1 \quad Y = 3,38$$

### Equivalent dynamic load

$$P_{eq} = 1 \cdot 3881 + 3,38 \cdot 1050 = 7430 \text{ N}$$

$$L_{10} = 100 \left( \frac{40750}{7430 \cdot 1} \right)^{10/3} = 29093 \text{ km}$$

### Limit load check

Equivalent limit load  $F_k$   
 $K = P_a/P_r = 0,27$

$$F_k = \frac{11900 \cdot 4250}{0,27 \cdot 11900 + (1 - 0,27 \tan 40) \cdot 4250} = 7780 \text{ N}$$

# Technical features

Guide roller safety coefficient

$$F_k/P_r = 7780 / 3881 = 2$$

## 2) The horizontal axis of a manipulator in steel industry

The centre of gravity of the vertical axis and load is placed in the middle of the horizontal centre-axis  $l_x$  and 160 mm distance from the guide axis.

The dirty environment and the possibility of shocks lead to the choice to ROLBLOC system.

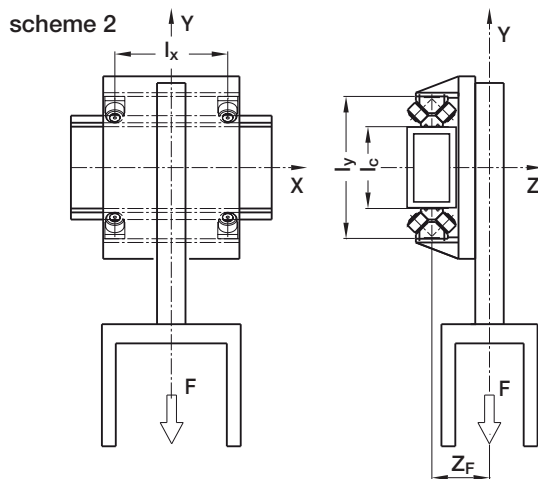

Guide rollers BL252 are used with guide GU62M  
 Overload factor  $f_w = 1,4$   
 Centre distance  $l_x = 350$  mm  $l_y = 400$  mm  
 $F = 6000$  N  $x = 0$   $y = -1000$   $z_F = 160$  mm

### Load on rollers

The effective center axis  $l_c$  is  $400 - 85 - 85 = 230$  mm

$$P_a = \frac{6000 \cdot 160}{2 \cdot 230} = 2087 \text{ N}$$

$$P_r = \frac{6000 \cdot (350+0)}{2 \cdot 350} + \frac{6000 \cdot 160 \tan 45}{2 \cdot 230} = 5087 \text{ N}$$

### Nominal life

From the ROLBLOC table  $X=1, Y=1$

$$P_{eq} = 1 \cdot 2087 + 1 \cdot 5087 = 7174 \text{ N}$$

$$L_{10} = 100 \left( \frac{59000}{7174 \cdot 1.4} \right)^{10/3} = 36577 \text{ km}$$

### Limit load check

$$K = P_a/P_r = 2087/5087 = 0,41$$

$$F_k = \frac{16800 \cdot 8400}{0.41 \cdot 16800 + (1 - 0.41 \tan 45) \cdot 8400} = 11915 \text{ N}$$

$$F_k/P_r = 11915 / 5087 = 2.3$$

## 3) The sliding door of a machine tool (rail on top)

The door is supported by the rail DC type on the upper edge and driven on bottom side by an auto-aligning carriage C3RAL on LM guide rail type. Because of the effect of the bottom rail there isn't any torque applied at the DC rail. The door weight acts in a plane coincident with the roller/rail vertical axis and as such there is no over turning moment. In this case, limit load calculation can be easily carried out from basic data  $F_r$  without  $F_k$  calculation.

Of course the calculation is always the same.



Guide rail DC18.65 is used with carriage  
 T4 PFV 3518 250

Overload factor  $f_w = 1,1$

Centre distance  $l_x = 213$  mm  $l_y = 113$  mm

$F = 450$  N  $x = -300$   $y = -500$   $z = 0$

(because of LM rail) mm

# Technical features

## Load on rollers

The effective centeraxis  $l_c$  is  $113 - 35 = 78$  mm

$$P_a = \frac{450 \cdot 0}{2 \cdot 78} = 0 \text{ N}$$

$$P_r = \frac{450 \cdot (213 + 2 \cdot 300)}{2 \cdot 213} + \frac{450 \cdot 0 \tan 40}{2 \cdot 213} = 859 \text{ N}$$

## Nominal life

$$L_{10} = 100 \left( \frac{4570}{859 \cdot 1,1} \right)^3 = 11300 \text{ km}$$

## Limit load check

$$F_r/P_r = 2120 / 859 = 2,4$$

## 4) Transfer unit

The box weight loads the carriage with max axial load. In this load configuration the limit load check calculation can be easily done directly by the  $F_a$  value without  $F_k$  calculation.

## Load on rollers

The effective center axis  $l_c$  is  $450 + 32 = 482$  mm

$$P_a = \frac{400}{4} + \frac{400 \cdot 650}{2 \cdot 482} = 370 \text{ N}$$

$$P_r = 370 \tan 40 = 310 \text{ N}$$

## Nominal Life

$$L_{10r} = 100 \left( \frac{5600}{310 \cdot 1,2} \right)^{10/3} = 840000 \text{ km}$$

$$L_{10a} = 100 \left( \frac{2100}{370 \cdot 1,2} \right)^{10/3} = 17760 \text{ km}$$

$$L_{10} = 17760 \text{ km}$$

## Limit load check

$$F_a/P_a = 950 / 370 = 2.5$$

For further details, contact the NADELLA Technical Service.

scheme 4

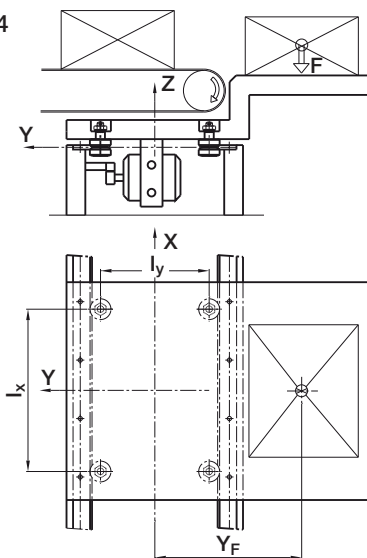

Guide rollers FRN(R)32EI with rails FSH32M

Overload factor  $f_w = 1,2$

Centre distance  $l_x = 670$  mm  $l_y = 450$  mm

$F=400$  N  $x=0$   $y=650$   $z = 50$  mm

# Guide rail order code

## Steel rail

**FSH 62 MT 1500 SB NW RR**

**GU** profile type  
**FS**  
**FSH**  
**FSX**  
**GP**

profile size

**M** ground  
**MT** cold drawn and sandblasted  
**MC** rough - ground

length (mm)

**NX** Stainless steel  
**NW** nickel plating  
**R** one ground end  
**RR** both ground ends

**SB** standard drilling  
**NZ** finished to drawing  
**NF** without holes  
**A** boring layout A (only GP range)  
**B** boring layout B (only GP range)

## Aluminium rail

**FWS 40 / 2000 NF NX**

**FWN** profile type  
**FWS**  
**FWH**  
**C**  
**DC**  
**LM**  
**LML**

profile size

length (mm)

**CH** chromium plate  
**R** one ground end  
**RR** both ground ends  
**NX** stainless steel rods

**SB** standard drilling  
**NZ** finished to drawing  
**NF** without holes



# Heavy-Line

## GU System

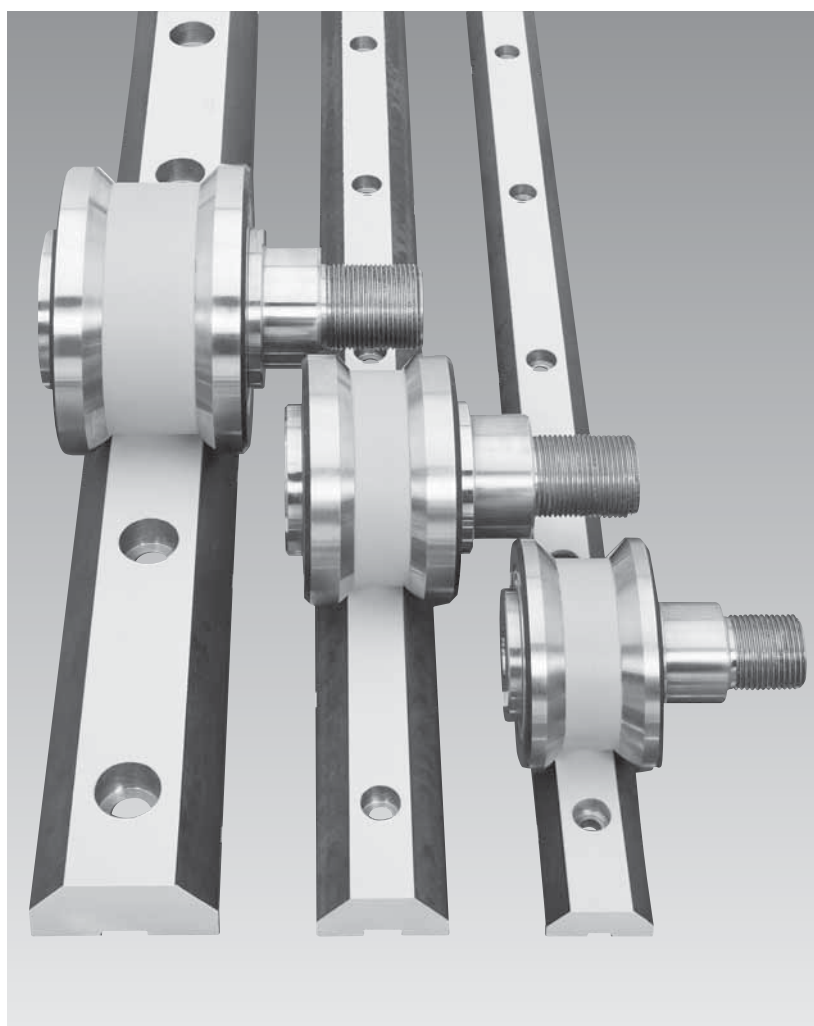

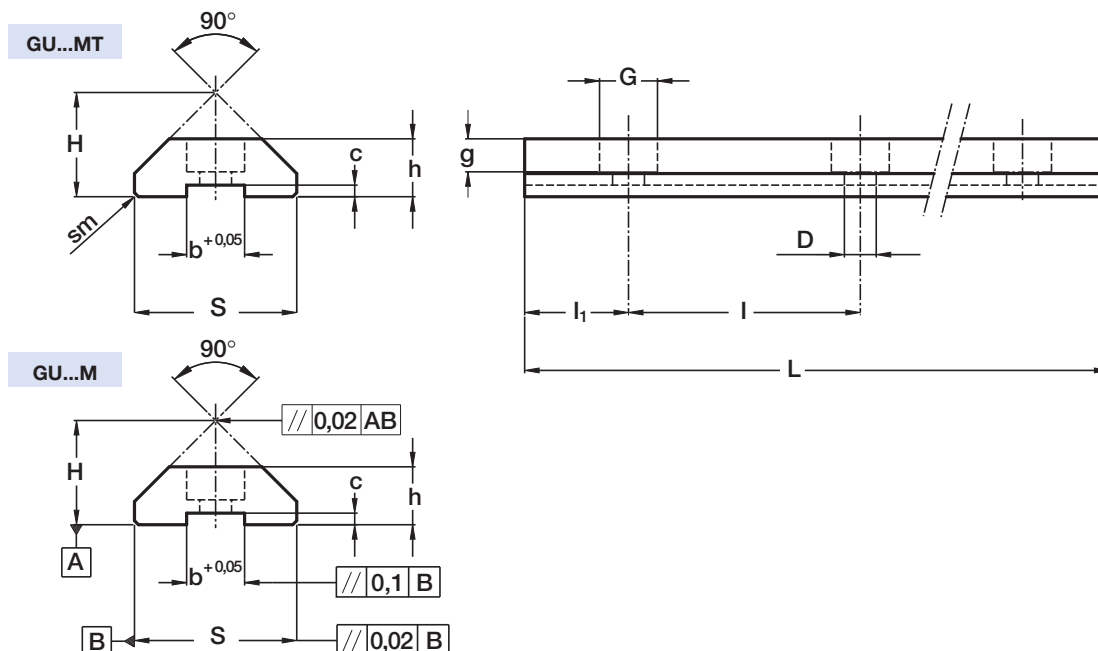

The longitudinal slot, made with + 0.05 tolerance, permits using reference elements SAG for guide positioning.

Type	Dimensions (mm)											Weight (kg/m) <sup>(2)</sup>
	H ± 0.05	h ± 0.05	S ± 0.05	D + 0.1	G	g	b + 0.05	c ± 0.05	sm	l	l <sub>1</sub>	
<b>GU 28 MT</b>	19	11	28.8	5.5	10	5.7	10	2.5	0.7x45°	90	30	1.97
<b>GU 35 MT</b>	23.9	15.7	35.5	6.6	11	6.8	10	3.8	1x45°	90	30	3.35
<b>GU 50 MT</b>	35.5	21	50.8	11	18	11	16	4.3	1x45°	90	30	6.89

max length in single element L=6 000 mm (1)

Type	Dimensions (mm)										Weight (kg/m) <sup>(2)</sup>
	H ± 0.05	h ± 0.05	S ± 0.05	D + 0.1	G	g	b + 0.05	c ± 0.05	l	l <sub>1</sub>	
<b>GU 28 M</b>	18	10	28	5.5	10	5.7	10	2	90	30	1.8
<b>GU 35 M</b>	23	15	35	6.6	11	6.8	10	3.3	90	30	3.2
<b>GU 50 M</b>	34.5	20	50	11	18	11	16	3.8	90	30	6.8

max length in single element L=4 020 mm (1)

(1) Longer rails are supplied in sections with ground butt joints - (2) Weight without holes

### Rails finishing

- drawn, induction hardened and sandblasted tracks (**MT**);
- drawn, induction hardened and ground (**M**)
- Induction hardening on raceways only

### Hole layout

- holes according to catalogue (**SB**)
- finishes to drawing (**NZ**)
- without holes (**NF**)

### Optional features

- ground one end (**R**)
- ground both ends (**RR**)
- chemical Nickel-plating (**NW**)

Example of standard designation: **GU 35 MT 4300 SB**

See page 17 for standard codification

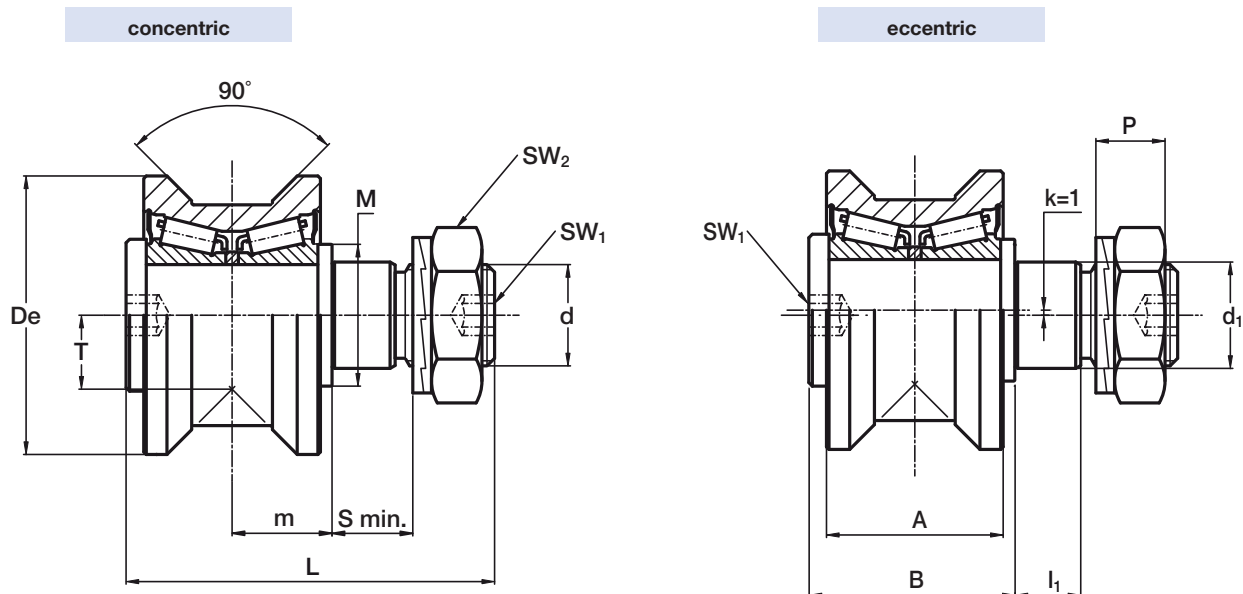
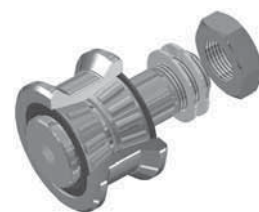

The sides of the race are convex with radius  $R = 400$ .

Type		Dimensions (mm)														
concentric	eccentric	De	d <sub>1</sub> <sup>(1)</sup>	d	T	m	S min.	P	L	A	B	l <sub>1</sub>	M	SW <sub>1</sub>	SW <sub>2</sub>	k
<b>RKU 55</b>	<b>RKUR 55</b>	55	21	M 20 x 1.5	14.6	19.8	15	13.4	73	35	41	14	28	8	30	1
<b>RKU 65</b>	<b>RKUR 65</b>	65	27	M 24 x 1.5	18.7	20.8	19	15.4	83	37	44	18	35	10	36	1
<b>RKU 75</b>	<b>RKUR 75</b>	75	36	M 30 x 1.5	23.7	27	19	21.6	100	45	55	18	44	12	46	1
<b>RKU 95</b>	<b>RKUR 95</b>	95	38	M 36 x 1.5	25.5	30.8	24	24.6	115	53 <sup>(5)</sup>	62	23	50	14	55	1
<b>RKU 115</b>	<b>RKUR 115</b>	115	42	M 36 x 1.5	33.5	34	33	24.6	135	60 <sup>(5)</sup>	70	32	56	14	55	1

Type		Dynamic load (N)	Limit loads (N)		Life coefficients		Torque wrench <sup>(2)</sup> settings (Nm)	Weight (kg)
		C <sub>w</sub> <sup>(6)</sup>	radial F <sub>r</sub>	axial F <sub>a</sub>	X	Y		
<b>RKU 55</b>	<b>RKUR 55</b>	41 650	11 900	4 250	1	3.42	80	0.6
<b>RKU 65</b>	<b>RKUR 65</b>	46 800	22 100	6 800	1	3.06	160	0.9
<b>RKU 75</b>	<b>RKUR 75</b>	66 700	31 300	10 100	1	2.95	300	1.6
<b>RKU 95</b>	<b>RKUR 95</b>	116 800	43 700	12 600	1	3.74	450	2.8
<b>RKU 115</b>	<b>RKUR 115</b>	182 450	55 600	17 900	1	3.64	450	4.9

1) Housing bore tolerance: H7

2) The torque wrench settings are given for non-lubricated threads; for lubricated threads, multiply figure by 0.8

3) Standard seals: material NBR, RS type

4) On request, the guide rollers can be supplied with external parts in stainless steel (suffix **NX**) and with Viton seals for operating temperatures up to 120°C (suffix **V**, not available for RKU 115). Internal rolling elements in standard bearing steel.

5) Dimensions relating to the stainless-steel rollers (suffix **NX**)

6) C<sub>w</sub> basic load for 100 km

7) The guide rollers include self-locking washers and hexagonal nut (DIN 439B) for fitting

8) Pressure angle  $\alpha$  for load calculation: 45°

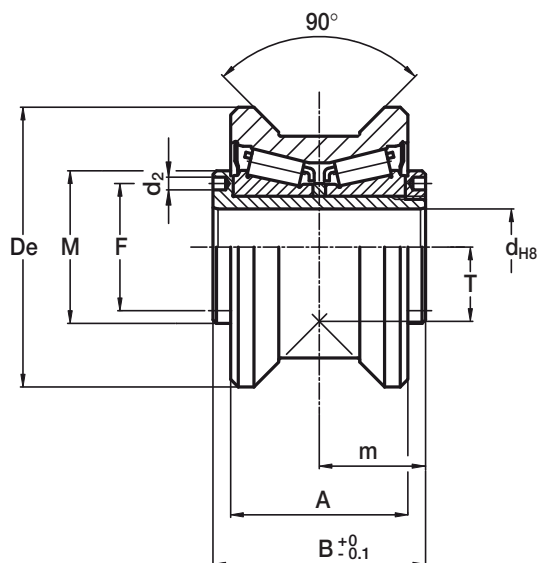

The sides of the race are convex with radius  $R = 400$ .

Type	Dimensions (mm)								
	De	d	T	m	A	B	F	d <sub>2</sub> <sup>(4)</sup>	M
FKU 55	55	15	14.6	21	35	42	25	2.5	30
FKU 65	65	20	18	22.5	37	45	29	3	35
FKU 75	75	25	23.7	28	45	56	37	4	44
FKU 95	95	28	25.5	32	53	56 <sup>(2)</sup>	64	4	49
FKU 115	115	35	33.5	36	60	63 <sup>(2)</sup>	72	4	59

Type	Dynamic load (N)	Limit loads (N)		Life coefficients		Weight (kg)
	C <sub>w</sub> <sup>(3)</sup>	radial F <sub>r</sub>	axial F <sub>a</sub>	X	Y	
FKU 55	41 650	11 900	4 250	1	3.42	0.5
FKU 65	46 800	22 100	6 800	1	3.06	0.6
FKU 75	66 700	31 300	10 100	1	2.95	1.2
FKU 95	116 800	43 700	12 600	1	3.74	2.3
FKU 115	182 450	55 600	17 900	1	3.64	3.9

1) On request, the guide rollers can be supplied with external parts in stainless steel (suffix **NX**) and with Viton seals for operating temperatures up to 120°C (suffix **V** not available for FKU 115). Internal rolling elements in standard bearing steel

2) Dimensions relating to the stainless-steel rollers (suffix **NX**)

3) C<sub>w</sub> basic load for 100 km

4) To prevent rotation between roller and shaft a pin can be fitted in one of the holes "d<sub>2</sub>" positioned in the side flange

5) Pressure angle α for load calculation: 45°

6) Standard seals: material NBR, RS type

## Floating guide rollers RKUL

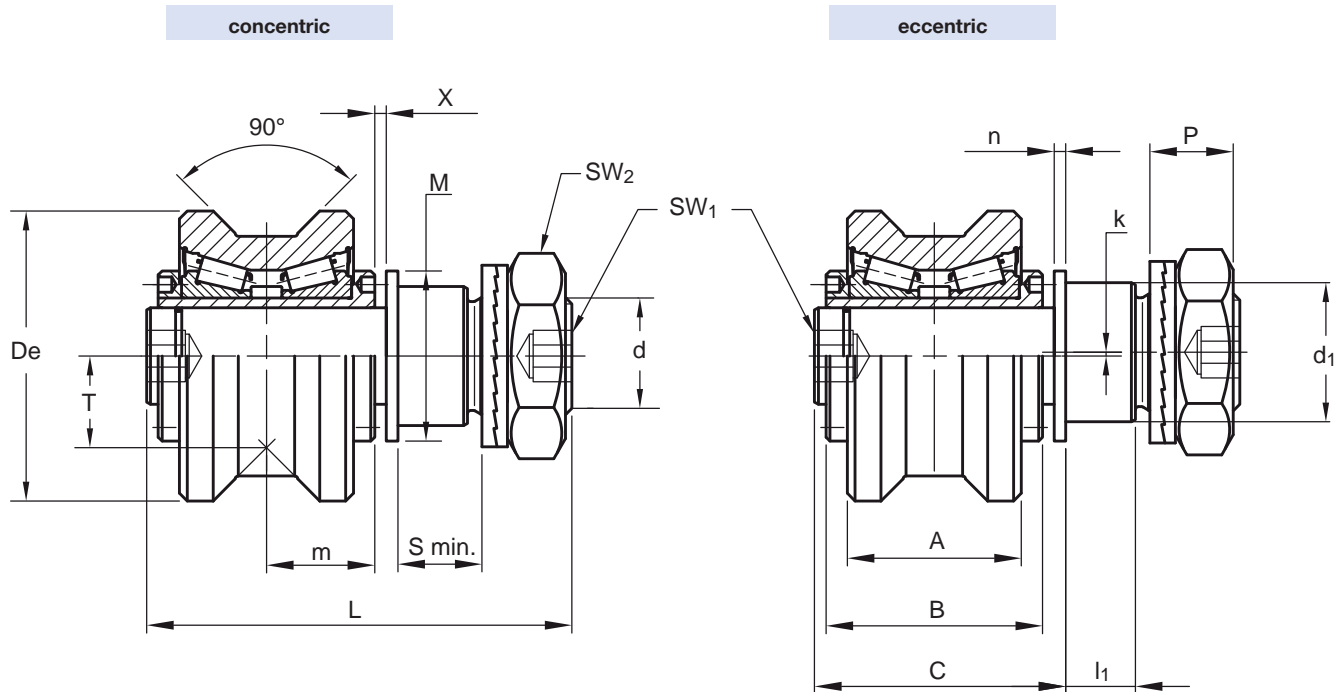

Type		Dimensions (mm)																		
concentric	eccentric	De	d <sub>1</sub> <sup>1)</sup>	d	T	m	n	X	S min.	P	L	A <sup>4)</sup>	B	C	l <sub>1</sub>	M	SW <sub>1</sub>	SW <sub>2</sub>	k	
<b>RKUL 55</b>	<b>RKULR 55</b>	55	21	M 20 x 1.5	14.6	21.0	3	3	15	13.4	83	35	42	51	14	30	8	30	1	
<b>RKUL 65</b>	<b>RKULR 65</b>	65	27	M 24 x 1.5	18.0	22.5	3	3	19	15.4	93	37	45	54	18	35	10	36	1	
<b>RKUL 75</b>	<b>RKULR 75</b>	75	36	M 30 x 1.5	23.7	28.0	3	3	19	21.6	110	45	56	65	18	44	12	46	1	
<b>RKUL 95</b>	<b>RKULR 95</b>	95	38	M 36 x 1.5	25.5	32.0	4	3.5	24	24.6	128	53	56 <sup>4)</sup>	64	75	23	49	14	55	1
<b>RKUL 115</b>	<b>RKULR 115</b>	115	42	M 36 x 1.5	33.5	36.0	4	3.5	33	24.6	148	60	63 <sup>4)</sup>	72	83	32	59	14	55	1

Type		Dynamic load (N)	Limit load (N)	Torque wrench settings <sup>2)</sup> (Nm)	Weight (g)
		C <sub>w</sub> <sup>3)</sup>	radial F <sub>r</sub>		
<b>RKUL 55</b>	<b>RKULR 55</b>	41650	3050	80	800
<b>RKUL 65</b>	<b>RKULR 65</b>	46800	6850	160	1100
<b>RKUL 75</b>	<b>RKULR 75</b>	66700	11200	300	1800
<b>RKUL 95</b>	<b>RKULR 95</b>	116800	13800	450	3000
<b>RKUL 115</b>	<b>RKULR 115</b>	182450	24000	450	5100

1) Housing bore tolerance: H7

2) The torque wrench settings are given for non-lubricated threads; for lubricated threads multiply figure by 0.8

3) C<sub>w</sub> = Basic load for 100 KM

4) Dimensions for stainless steel (NX) version

On request the guide rollers can be supplied with external parts in stainless steel (suffix **NX**). Internal rolling elements in standard bearing steel

Standard seals: material NBR, RS type

On request guide rollers can be supplied with Viton seals for operating temperatures up to 120°C (suffix **V**, not available for RKUL 115)

The guide rollers include self-locking washers and hexagonal nut (DIN 439B) for fitting

Pressure angle  $\alpha$  for load calculation: 45°

# Heavy-Line

## Lubricator LUBU

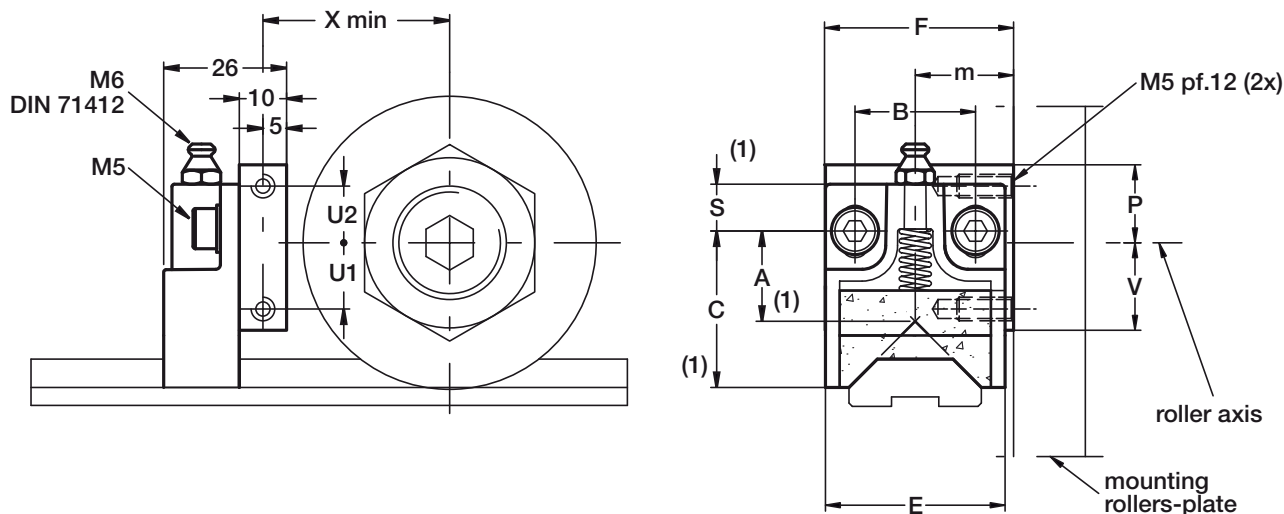
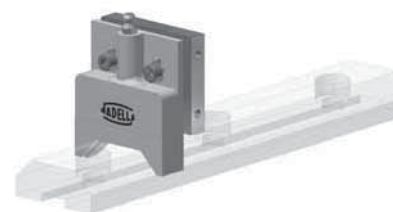

Type	Dimensions (mm)												Weight (g)	Suggested combinations
	X	U1	U2	F	m	B	S	C	A	E	V	P		
LUBU 55	35	12	14	40	19.8	25.5	10	34	20	38	16.5	18.5	65	RKU 55 RKUR 55 FKU 55
LUBU 65	40	14	12	40	20.8	25.5	10	34	20	38	18.5	16.5	65	RKU 65 RKUR 65 FKU 65
LUBU 75	45	19	11	50	27	25.5	1	43	25.4	44	24	16	85	RKU 75 RKUR 75 FKU 75
LUBU 95	55	21	9	60	30	30	16.5	50	24.9	58	31	19	140	RKU 95 RKUR 95 FKU 95
LUBU 115	65	30	0	63	34	30	16.5	50	24.9	58	40	10	140	RKU 115 RKUR 115 FKU 115

1) The dimension of the plastic part refers to the centre of the regulation-slot. Allows a translation of +/- 3 mm.

2) The lubricator is supplied with the felt already lubricated. The lubricant has a mineral oil base.

3) During the mounting fix the aluminium support to the rollers plate, adjust the height of the plastic part in order to put it in contact with the raceways and then block it in that position with the M5 screws.

### Optional features

- felt without lubricant (D)

# Heavy-Line

## Guide pins SAG

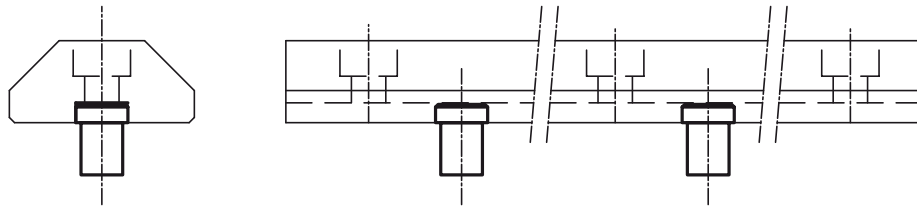
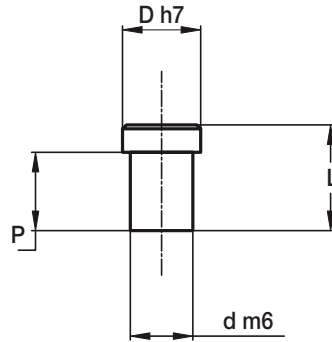

Pin type	Guide type	Dimensions (mm)			
		D	d <sup>(1)</sup>	P	L
SAG 28	GU 28 MT	10	8	10	12.3
SAG 35	GU 35 MT	10	8	10	13.5
SAG 50	GU 50 MT	16	10	11.2	15

1) Housing bore tolerance: H7

## Guide roller combinations (RKU, FKU, RKUL)

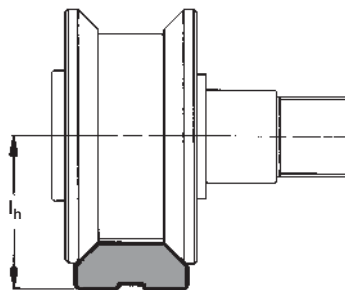

Guide \ Roller	l <sub>h</sub> (mm)				
	RKU, FKU, RKUL 55	RKU, FKU, RKUL 65	RKU, FKU, RKUL 75	RKU, FKU, RKUL 95	RKU, FKU, RKUL 115
GU 28 MT	33.6	37	-	-	-
GU 28 MT	32.6	36	-	-	-
GU 35 MT	-	41.9	47.6	-	-
GU 35 MT	-	41	46.7	-	-
GU 50 MT	-	-	-	61	69
GU 50 MT	-	-	-	60	68

# Heavy-Line

## Mounting Examples

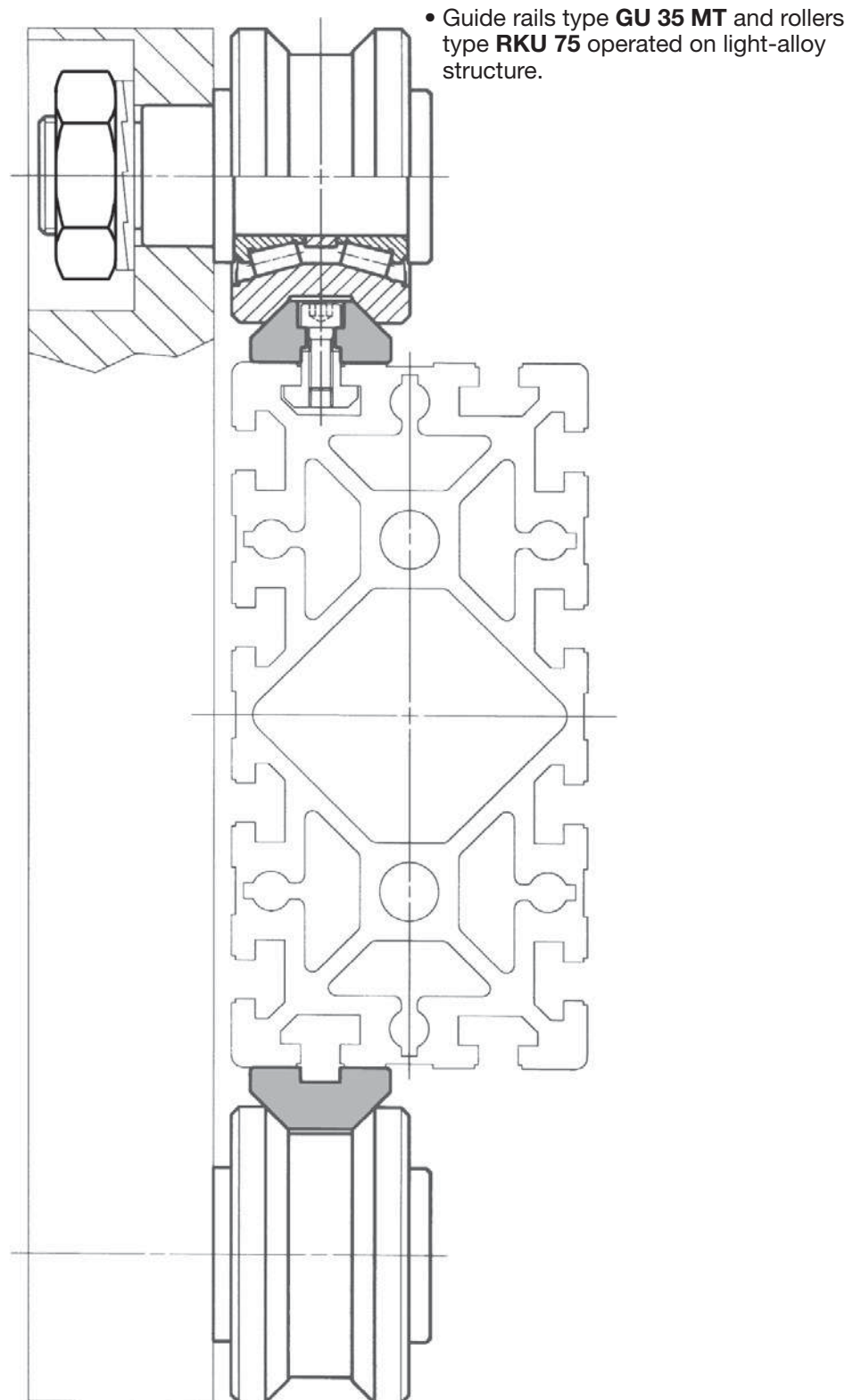

# Heavy-Line

## GP System



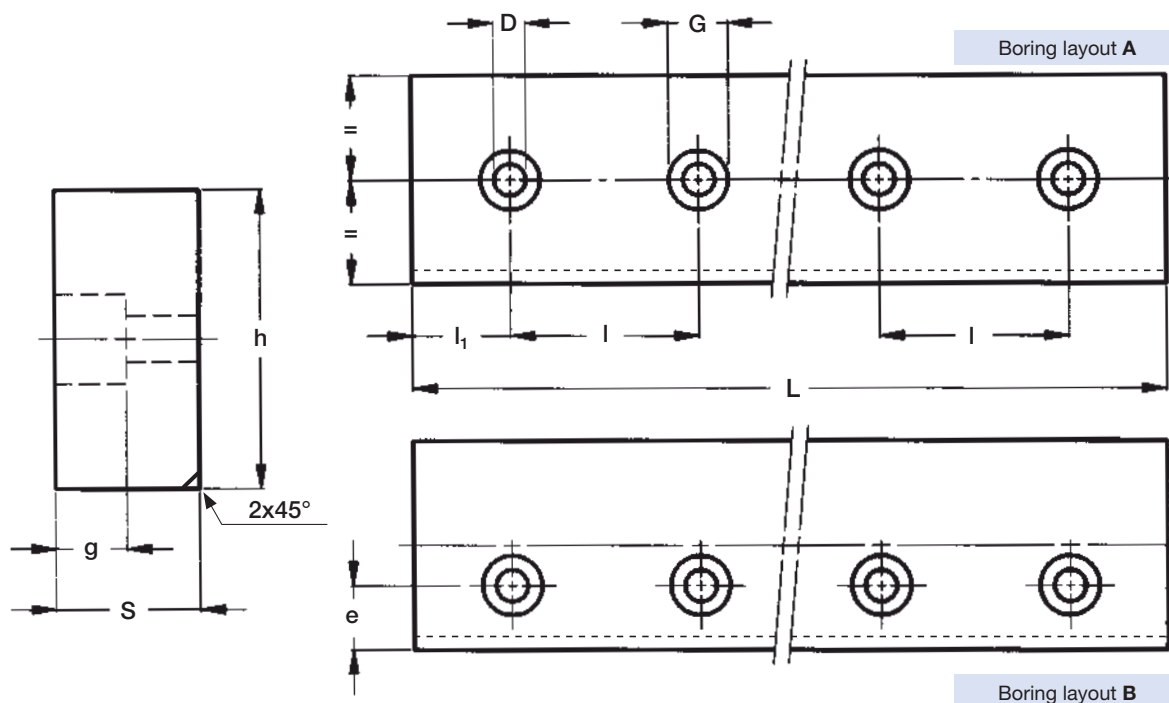

Type	Dimensions (mm)								Weight <sup>(2)</sup> (kg/m)
	h ± 0.05	S ± 0.05	D	G	g	e	l	l <sub>1</sub>	
GP 2626 MC	26	26	9	15	9	(3)	120	50	5.3
GP 3232 MC	32	32	9	15	9	(3)	150	60	8.1
GP 3617 MC	36	17	6.5	11	6.8	12.5	120	50	4.8
GP 4321 MC	43	21	9	15	9	11.5	150	60	7
GP 5050 MC	50	50	18	26	17	(3)	180	60	19.6
GP 6222 MC	62	22	9	15	9	21	150	60	10.7
GP 7232 MC	72	32	13.5	20	13	24	180	70	18.1
GP 8222 MC	82	22	13.5	20	13	20	180	70	14.2

Max length of single guide element L = 5 800 mm <sup>(1)</sup>

1) Longer rails are supplied in sections with ground butt joints

2) Weight without holes

3) For boring layout A only

### Rails finishing

- material: C60 or C45
- induction hardened on every side
- surface finished by a rough grinding (MC)

### Hole layout

- holes according to catalogue (A or B)
- finishes to drawing (NZ)
- without holes (NF)

### Optional features

- ground one end (R)
- ground both ends (RR)
- chemical nickel plating (NW)

Example of standard designation: **GP 6222 MC 4300 B**

See page 17 for standard codification

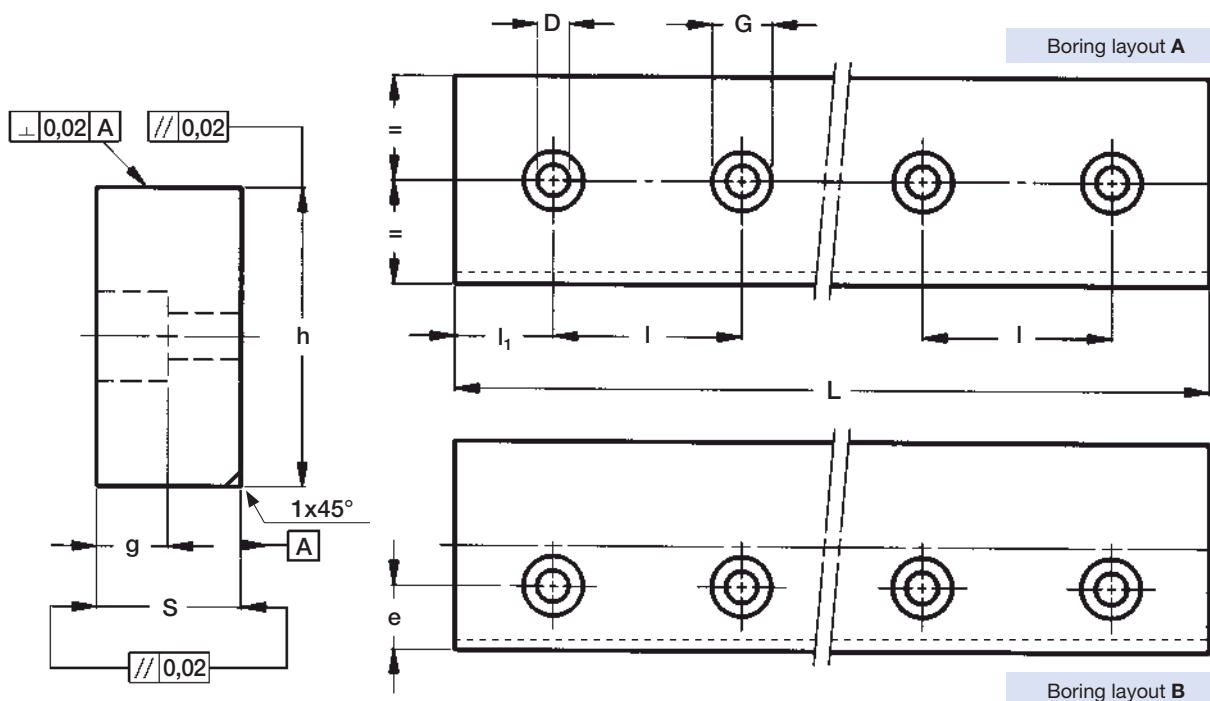

Type	Dimensions (mm)								Weight <sup>(2)</sup> (kg/m)
	h $\pm 0,05$	S $\pm 0,05$	D	G	g	e	I	I <sub>1</sub>	
GP 2525 M	25	25	9	15	8.5	(3)	120	50	4.9
GP 3131 M	31	31	9	15	8.5	(3)	150	60	7.5
GP 3516 M	35	16	6.5	11	6.8	12	120	50	4.4
GP 4220 M	42	20	9	15	9	11	150	60	6.5
GP 6121 M	61	21	9	15	9	20.5	150	60	10
GP 7131 M	71	31	13.5	20	12.5	23.5	180	70	17.3
GP 8121 M	81	21	13.5	20	13	19.5	180	70	13.4

Max length of single guide element L = 4 020 mm <sup>(1)</sup>

- 1) Longer rails are supplied in sections with ground butt joints (max. length with treatment NW on request)
- 2) Weight without holes
- 3) Only available according to figure A

### Rails finishing

- material: C60 or C45
- induction hardened and ground tracks on every side (M);

### Hole layout

- holes according to catalogue (A or B)
- finishes to drawing (NZ)
- without holes (NF)

### Optional features

- ground one end (R)
- ground both ends (RR)
- chemical Nickel-plating (NW)

Example of standard designation: **GP 6121 M 2070 B**

See page 17 for standard codification

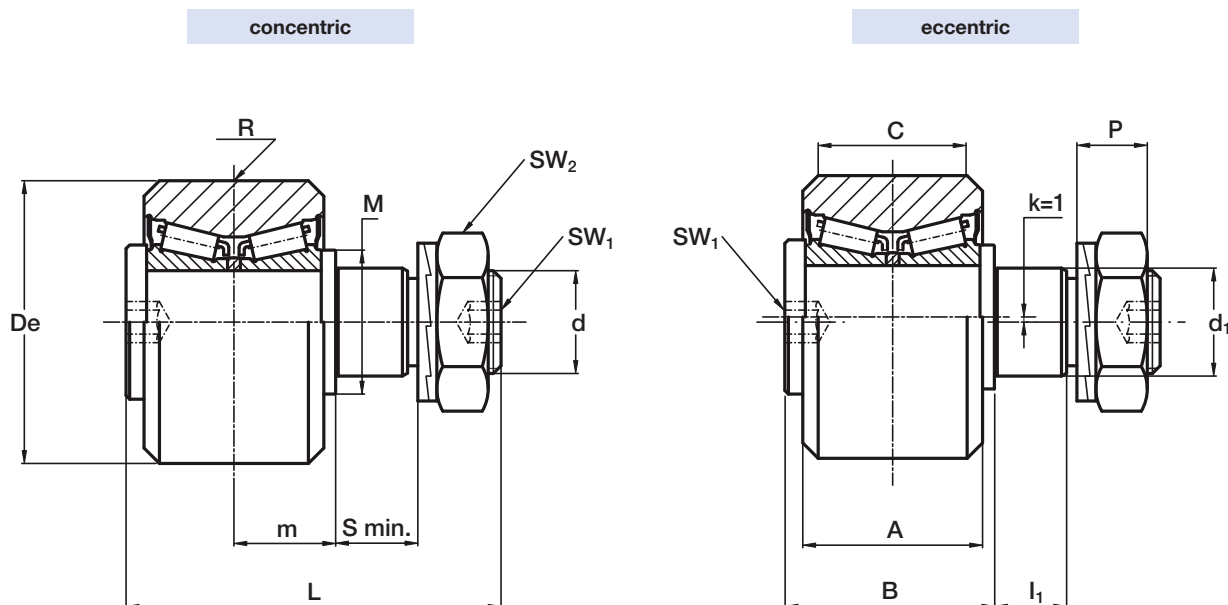

Type		Dimensions (mm)																
concentric	eccentric	De	d <sub>1</sub> <sup>(1)</sup>	d	m	S min.	P	L	A	B	C	R	l <sub>1</sub>	M	SW <sub>1</sub>	SW <sub>2</sub>	k	
PK 52C	PKR 52C	52	21	M 20 x 1.5	19.8	15	13.4	73	35	41	29	800	14	28	8	30	1	
PK 62C	PKR 62C	62	27	M 24 x 1.5	20.8	19	15.4	83	37	44	29	800	18	35	10	36	1	
PK 72C	PKR 72C	72	36	M 30 x 1.5	27	19	21.6	100	45	55	33	1 200	18	44	12	46	1	
PK 90C	PKR 90C	90	38	M 36 x 1.5	30.8	24	24.6	115	53	56 <sup>(5)</sup>	62	45	1 200	23	50	14	55	1
PK 110C	PKR 110C	110	42	M 36 x 1.5	34	33	24.6	135	60	63 <sup>(5)</sup>	70	48	1 200	32	56	14	55	1

Type		Dynamic load (N)	Limit load (N)	Torque <sup>(2)</sup> wrench setting (Nm)	Weight (Kg)
		C <sub>w</sub> <sup>(6)</sup>	radial F <sub>r</sub>		
PK 52C	PKR 52C	42 100	11 900	80	0.6
PK 62C	PKR 62C	47 750	22 100	160	0.9
PK 72C	PKR 72C	67 450	31 300	300	1.6
PK 90C	PKR 90C	118 000	43 700	450	2.8
PK 110C	PKR 110C	185 000	55 600	450	4.9

1) Housing bore tolerance: H7

2) The torque wrench settings are given for non-lubricated threads; for lubricated threads, multiply figure by 0.8

3) Standard seals: material NBR, RS type

4) On request, the guide rollers can be supplied with external parts in stainless steel (suffix **NX**) and with Viton seals for operating temperatures up to 120°C (suffix **V**, up to dimension PK 90 C included). Internal rolling elements in standard bearing steel

5) Dimensions relating to the stainless-steel rollers (suffix **NX**)

6) C<sub>w</sub> basic load for 100 km

7) The guide rollers are complete with self-locking washers and hexagonal nut for fitting

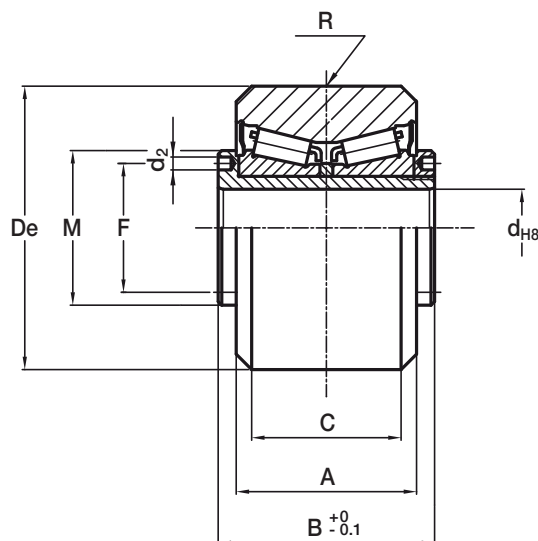

Type	Dimensions (mm)								
	De	d	A	B	C	R	F	d <sub>2</sub>	M
<b>FK 52C</b>	52	15	35	42	29	800	25	2.5	30
<b>FK 62C</b>	62	20	37	45	29	800	29	3	35
<b>FK 72C</b>	72	25	45	56	33	1 200	37	4	44
<b>FK 90C</b>	90	28	53	56 <sup>(3)</sup> 64	45	1 200	42	4	49
<b>FK 110C</b>	110	35	60	63 <sup>(3)</sup> 72	48	1 200	52	4	59

Type	Dynamic load (N)	Limit load (N)	Weight (kg)
	C <sub>w</sub> <sup>(4)</sup>	radial F <sub>r</sub>	
<b>FK 52C</b>	42 100	11 900	0.5
<b>FK 62C</b>	47 750	22 100	0.6
<b>FK 72C</b>	67 450	31 300	1.2
<b>FK 90C</b>	118 000	43 700	2.3
<b>FK 110C</b>	185 000	55 600	3.9

1) Standard seals: material NBR, RS type

2) On request, the guide rollers can be supplied with external parts in stainless steel (suffix **NX**) and with Viton seals for operating temperatures up to 120°C (suffix **V**, up to dimension FK 90 C included). Internal rolling elements in standard bearing steel

3) Dimensions relating to the stainless-steel rollers (suffix **NX**)

4) C<sub>w</sub> basic load for 100 km

5) To prevent rotation between roller and shaft a pin can be fitted in one of the holes “d<sub>2</sub>” positioned in the side flange



### concentric

GC  
GC...EE with plastic seals  
GC...EEM with metal shields

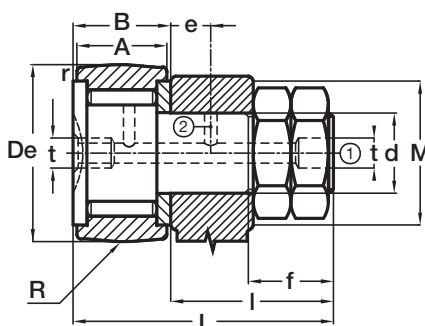

Execution EE, EEM

### eccentric

GCR  
GCR...EE with plastic seals  
GCR...EEM with metal shields

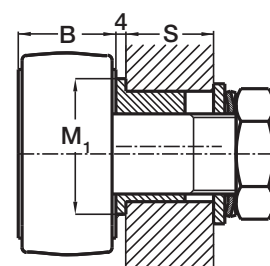
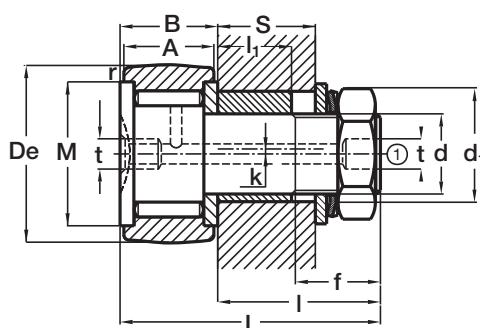

GCR 62

Holes (1) and (2) beginning from De=30 mm

GCR 19 ÷ 52

Type (1)		Dimensions (mm)																
		De	A	B max	d	d <sub>1</sub> (7)	k	L max	l max	f	pitch	r min	t	e	M (6)	M <sub>1</sub>	P (2)	l <sub>1</sub>
GC 19	GCR 19	19	11	12.2	8	11	0.5	32.7	20.5	10	1.25	0.3	4	-	15.3	-	-	10
GC 22	GCR 22	22	12	13.2	10	14	1	36.7	23.5	12	1.25*	0.3	4	-	18.2	-	-	11
GC 24	GCR 24	24	12	13.2	10	14	1	36.7	23.5	12	1.25*	0.3	4	-	18.2	-	-	11
GC 26	GCR 26	26	12	13.2	10	14	1	36.7	23.5	12	1.25*	0.3	4	-	20.8	-	-	11
GC 28	GCR 28	28	12	13.2	10	14	1	36.7	23.5	12	1.25*	0.3	4	-	20.8	-	-	11
GC 30	GCR 30	30	14	15.2	12	16	1	40.7	25.5	13	1.5	0.6	4	6	24.8	-	8	11
GC 32	GCR 32	32	14	15.2	12	16	1	40.7	25.5	13	1.5	0.6	4	6	24.8	-	8	11
GC 35	GCR 35	35	18	19.6	16	21	1,5	52.6	33	17	1.5	0.6	6	8	28.8	-	10	14
GC 40	GCR 40	40	20	21.6	18	24	1,5	58.6	3	19	1.5	1	6	8	33.8	-	12	16
GC 47	GCR 47	47	24	25.6	20	27	2	66.6	41	21	1.5	1	6	9	38.7	-	14	17.5
GC 52	GCR 52	52	24	25.6	20	27	2	66.6	41	21	1.5	1	6	9	38.7	-	14	17.5
GC 62	GCR 62	62	29	30.6	24	36	3	80.6	50	25	1.5	1	6	11	52	44	12	18

\* These threads may be supplied with pitch of 1 mm (clamping torque 13 Nm)

- Housing bore tolerance: H7

- The guide rollers are complete with washers and hexagonal nut for fitting

## Guide rollers GC

- 1) Specification for followers with cylindrical outer ring: GCL, GCRL, GCL...EE, GCL...EEM, GCRL...EEM. On request the followers can be supplied possessing a screw driver slot at the threaded end of the stud (suffix **AK**).
- 2) Followers with outer diameter up to 28 mm included possess a screw driver slot on the head. Followers with outer diameter from 30 to 52 mm included can possess the screw driver slot or the hexagonal socket. For outer diameter above 52 mm the followers possess the hexagonal socket.
- 3) The load shown is limited by the strengths of the stud and outer ring.
- 4) With oil lubrication of followers without seals GC, GCR, GCL e GCRL, these speeds can be increased by 30% for continuous rotation or up to 50% momentarily.
- 5) These torques are shown for dry threads. For lubricated threads, take 0,8 of these values.
- 6) Minimum recommended abutment diameter in case of high axial load or in the presence vibrations.
- 7) The eccentric collar is tightly fitted on the follower stud.
- 8)  $C_w$  dynamic load for 100 Km

### DIRECTION FOR ADJUSTMENT OF THE EXCENTER

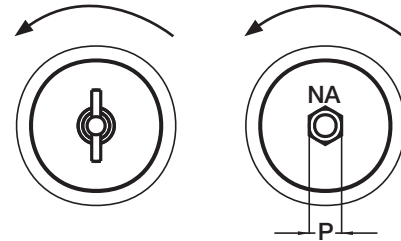

			Dynamic load (N)	Limit load (3) (N)				Speed limit grease lubrication r.p.m. (4)	Torque wrench setting (Nm) (5)	
S		R		GC...		GCR...			GC...	GCR...
min	max		$C_w$ (8)	Dyn. $F_r$	Stat. $F_{or}$	Dyn. $F_r$	Stat. $F_{or}$			
10.5	13	160	4 900	2 830	5 200	2 830	4 500	7 600	8	5
11.5	14	200	5 600	4 900	8 100	4 900	5 600	6 300	20	16
11.5	14	200	6 300	5 200	9 200	5 200	5 600	6 300	20	16
11.5	14	200	8 400	5 200	9 600	5 200	6 100	5 500	20	16
11.5	14	200	9 200	5 200	9 600	5 200	6 100	5 500	20	16
11.5	14.5	250	12 700	7 700	14 300	7 700	10 400	4 800	26	22
11.5	14.5	250	13 800	7 700	14 300	7 700	10 400	4 800	26	22
14.5	19	320	19 800	11 400	24 000	11 000	11 000	3 850	64	55
16.5	22	400	21 400	14 200	27 000	12 300	12 300	3 150	90	75
18	25	500	31 800	21 400	40 000	21 400	23 700	2 700	120	100
18	25	500	39 400	21 400	40 000	21 400	23 700	2 700	120	100
18.5	25.5	640	51 300	31 000	57 500	28 800	28 800	2 330	220	180

Favourite sizes are: 19/22/26/30/35/40/52/62

Track rollers in stainless steel are available on stock in the following sizes: 19/26/30/35/40 (suffix **NX**). Internal rolling elements in standard bearing steel

## Cam followers FG (needle) and FGU (roller)



FG series without seals  
FG...EEM series with metal shields

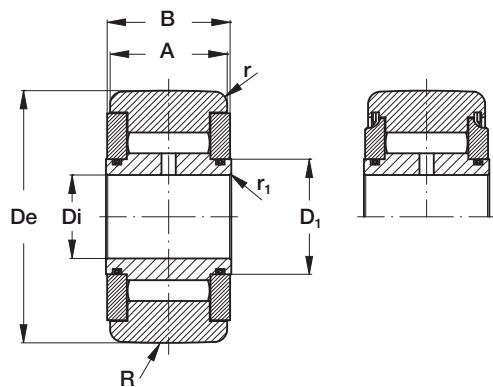

FGU  
FGU...MM series: with metal shields

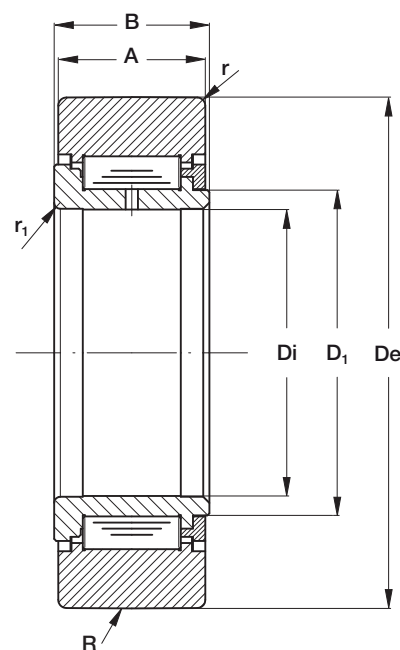

Type	Dimensions (mm)								
	De	Di	A	B max	D <sub>1</sub>	M (1) min	r min	r <sub>1</sub> min	R
FG 6 19	19	6	11	12	8.5	12	0.3	0.3	160
FG 10 30	30	10	14	15	13.8	19.5	0.6	0.3	250
FG 12 32	32	12	14	15	16	21.5	0.6	0.3	250
FG 15 35	35	15	18	19	18.7	24	0.6	0.3	320
FG 17 40	40	17	20	21	22	28	0.6	0.3	400
FG 20 47	47	20	24	25	25.7	32.5	1	0.3	500
FG 25 52	52	25	24	25	30.5	37	1	0.3	500
FG 30 62	62	30	28	29	35.2	44	1	0.3	640
FG 35 72	72	35	28	29	41	50	1	0.6	640
FG 40 80	80	40	30	32	46.7	56	1	0.6	800
FG 50 90	90	50	30	32	59.1	69	1	0.6	800
FGU 55 100	100	55	34	36	64	75.8	1.5	0.6	800
FGU 60 110	110	60	34	36	69.5	81.5	1.5	0.6	800
FGU 65 120	120	65	40	42	74.5	86.7	1.5	0.6	900
FGU 75 130	130	75	40	42	84	97	1.5	0.6	900

# Heavy-Line

## Cam followers FG (needle) and FGU (roller)

- 1) Minimum recommended abutment diameter.
- 2)  $C_w$  dynamic load 100 KM. These capacities are to be used for all types when the convex outer ring rotates directly on a cam. They take account of the repetitive loads on the follower and consequent deformation of the outer ring.
- 3) The load shown is limited by the strength of the outer ring when mounted in a housing.
- 4) With oil lubrication of followers without seals FG, FGL types, these speeds can be increased by 30% for continuous rotation or, up to 50% momentarily

Dynamic load (N) (2)	Limit loads (3) (N)		Speed limit grease lubrication (4) r.p.m.
$C_w$	Dyn. F	Sta. Fo	
4 960	4 050	6 700	7 600
12 670	8 500	15 500	4 800
12 910	8 300	16 200	4 200
18 510	12 200	25 600	3 750
23 870	14 200	31 000	3 150
31 800	21 400	44 500	2 700
33 590	23 600	48 000	2 330
47 000	38 000	73 000	2 050
55 560	49 000	90 000	1 800
71 180	66 000	123 000	1 620
69 650	74 000	123 000	1 300
111 350	53 400	109 000	1 900
127 630	64 000	129 000	1 770
163 760	89 000	174 000	1 650
170 796	97 000	185 000	1 480

# Heavy-Line

## Lubricator LUBP

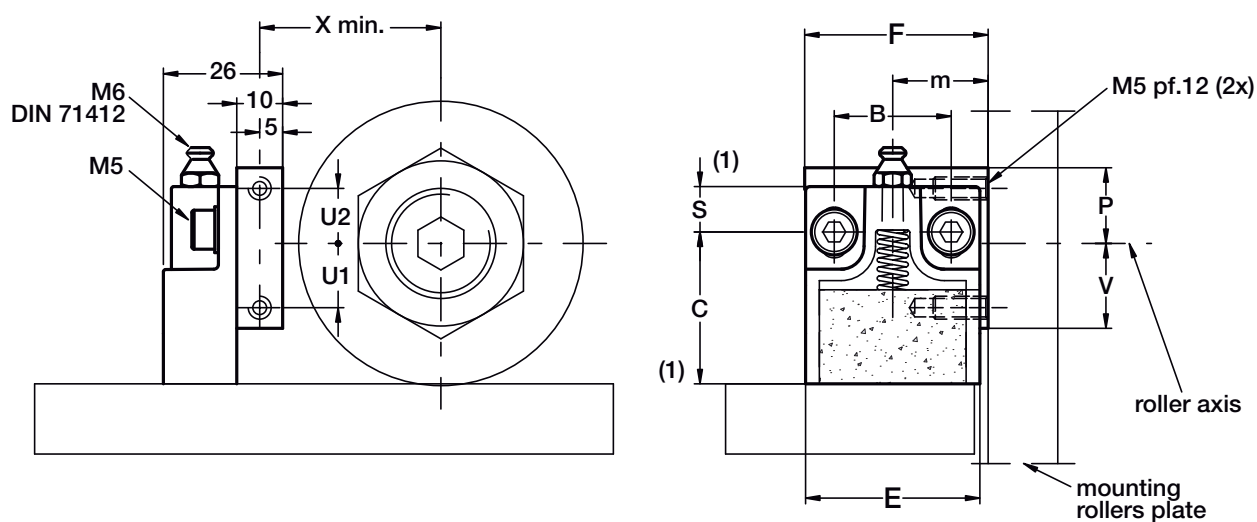
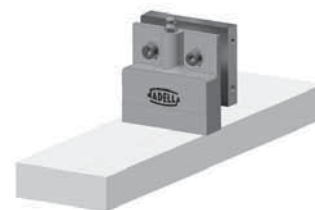

Type	Dimensions (mm)											Weight (g)	Suggested combinations
	X	U1	U2	F	m	B	S	C	E	V	P		
LUBP 52	33.5	12	14	40	19.8	25.5	10	32.5	38	16.5	18.5	65	PK 52 C PKR 52 C FK 52 C
LUBP 62	38.5	14	12	40	20.8	25.5	10	32.5	38	18.5	16.5	65	PK 62 C PKR 62 C FK 62 C
LUBP 72	43.5	19	11	50	27	25.5	10	40	44	24	16	85	PK 72 C PKR 72 C FK 72C
LUBP 90	52.5	21	9	60	30	30	16.5	43.5	58	31	19	140	PK 90 C PKR 90 C FK 90 C
LUBP 110	62.5	30	0	63	34	30	16.5	43.5	58	40	10	140	PK 110 C PKR 110 C FK 110 C

- 1) The dimension of the plastic part refers to the centre of the regulation slot. The regulation slot allows a translation of +/- 3 mm
- 2) The lubricator is supplied with the felt already lubricated. The lubricant has a mineral oil base
- 3) During the mounting fix the aluminium support to the rollers plate, adjust the height of the plastic part in order to put it in contact with the raceways and then block it in that position with the M5 screws.

### Optional features

- felt without lubricant (D)

# Heavy-Line

## Guide rollers combinations

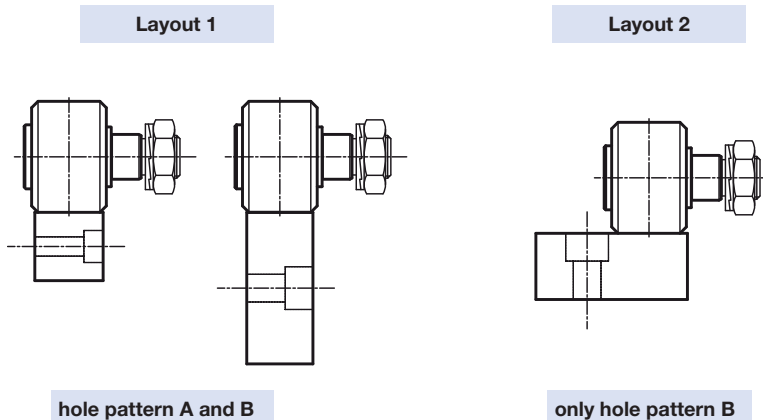

Layout 1	GC												PK/FK				
	19	22	24	26	28	30	32	35	40	47	52	62	52	62	72	90	110
GP2626MC / GP2525M	•	•	•	•	•	•	•	•	•								
GP3232MC / GP3131M										•	•	•	•	•			
GP3617MC / GP3516M	•	•	•	•	•	•	•										
GP4321MC / GP4220M						•	•	•									
GP5050MC															•	•	•
GP6222MC / GP6121M								•	•								
GP7232MC / GP7131M										•	•	•	•	•	•		
GP8222MC / GP8121M																	

Layout 1	FG/FGU														
	6 19	10 30	12 32	15 35	17 40	20 47	25 52	30 62	35 72	40 80	50 90	55 100	65 120	75 130	
GP2626MC / GP2525M	•	•	•	•	•										
GP3232MC / GP3131M						•	•	•	•	•	•				
GP3617MC / GP3516M	•	•	•												
GP4321MC / GP4220M		•	•	•											
GP5050MC												•	•	•	
GP6222MC / GP6121M				•	•										
GP7232MC / GP7131M						•	•	•	•	•	•				
GP8222MC / GP8121M															

Layout 2	GC												PK/FK				
	19	22	24	26	28	30	32	35	40	47	52	62	52	62	72	90	110
GP3617MC / GP3516M	•	•	•	•	•	•	•										
GP4321MC / GP4220M						•	•	•									
GP6222MC / GP6121M								•	•	•	•	•	•	•			
GP7232MC / GP7131M										•	•	•	•	•	•		
GP8222MC / GP8121M															•	•	•

Layout 2	GC														
	6 19	10 30	12 32	15 35	17 40	20 47	25 52	30 62	35 72	40 80	50 90	55 100	60 110	65 120	75 130
GP3617MC / GP3516M	•	•	•												
GP4321MC / GP4220M			•	•	•										
GP6222MC / GP6121M				•	•	•	•	•	•						
GP7232MC / GP7131M						•	•	•	•	•	•	•	•		
GP8222MC / GP8121M												•	•	•	•

In the tables above the suggested combinations. Other combinations are possible but guide rollers must not run over the holes.



# Heavy-Line

## Mounting examples

MARBLE MACHINERY  
Heavy-Line systems  
GU and GP

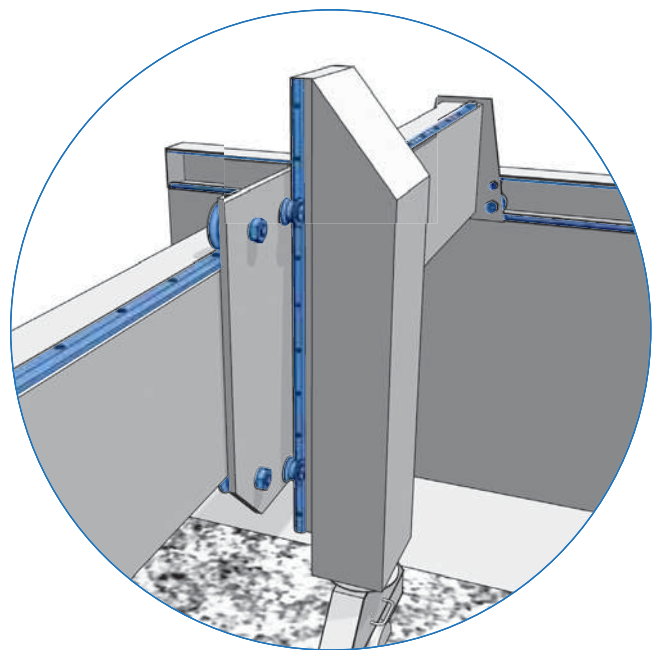
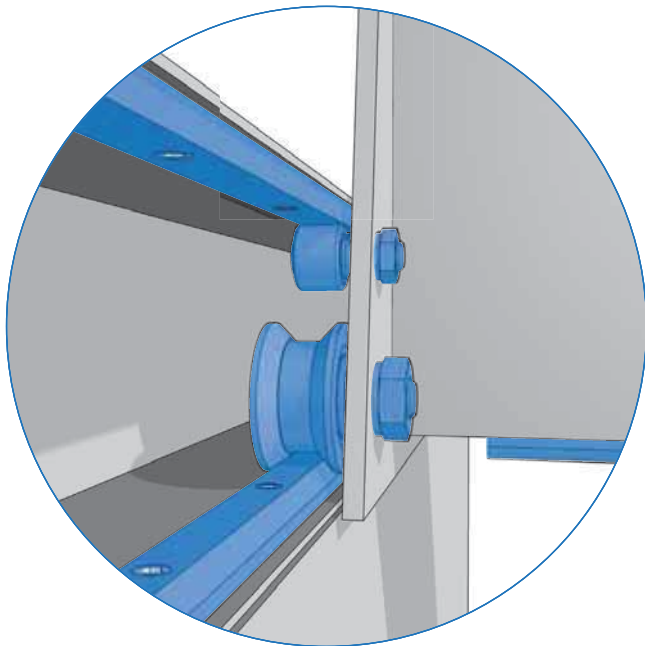
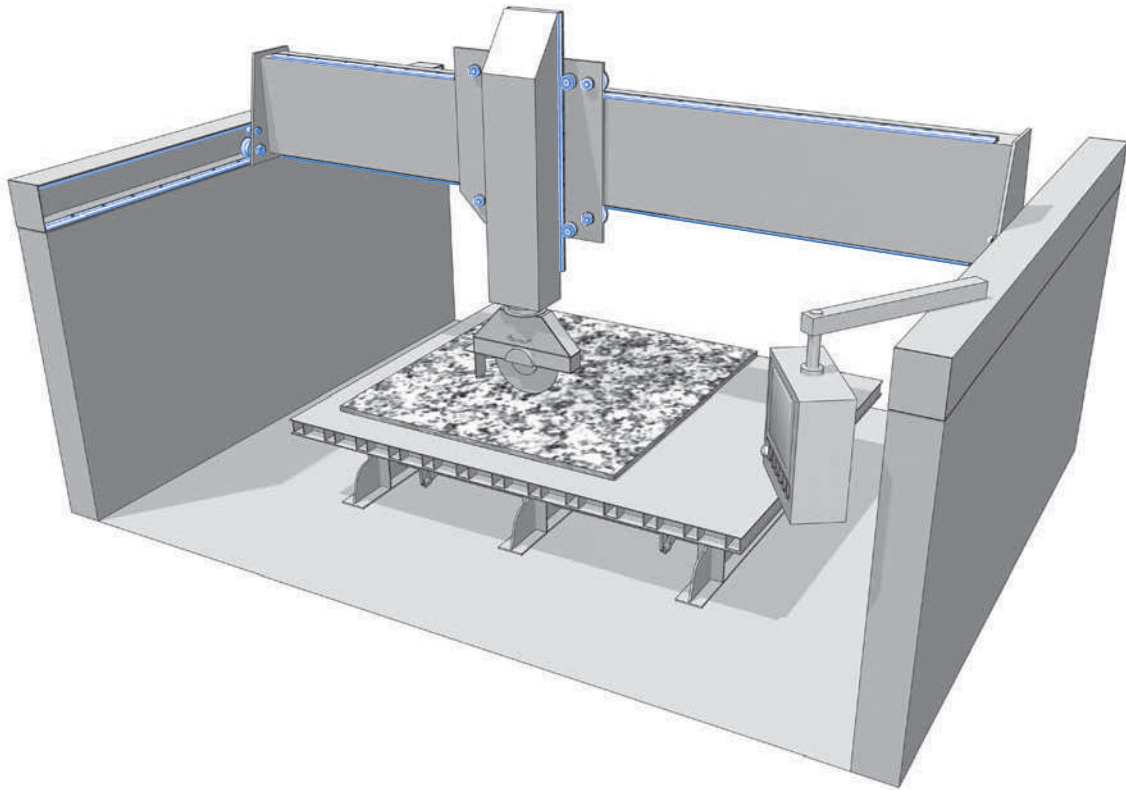

# Rolbloc

## Rolbloc System

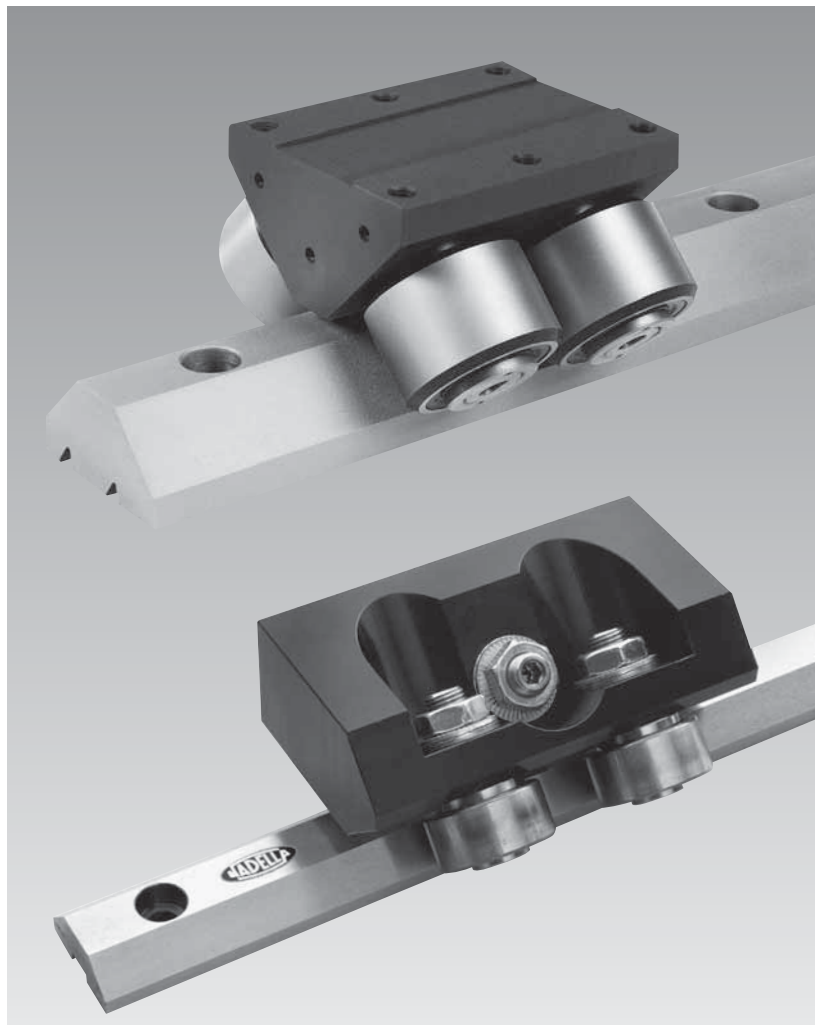

## Rolbloc system

The carriages based on Rolbloc's system are recommended for applications with heavy loads, high frequency of work and aggressive environment (dust, abrasive).

For the profiled guide rollers, the contact between the rollers and the rail takes place on the ground raceways, which are inclined respect the rotation axis of the guide roller. Due to this inclination angle in the contact area there is a dragging proportional to the dimension of the contact area and to the value of the inclination angle. In the ROLBLOC system the rotation axes of the roller guides are parallel to the raceways of the rail, with the following pure rolling. The pure rolling recudes the superficial stress and the effects of the dust between the surfaces.

### Technical features

**ROLBLOC** carriages **BL2..** and **BL4..** are composed by a body in burnished steel on which are mounted two or four roller guides equipped with tapered rollers (similar to flat roller guides type PK..C). The final part of the code (that can be 52, 75 or 115) shows the external diameter of the roller guides.

**MBL** carriages are composed by an alluminium body provided, on one side, with four threaded screws that allow the direct mounting on the fixing plate. Besides, in order to facilitate the aligning, there are also two pin screws. The body is equipped with guide rollers with a double row angular contact ball bearing. On the body are mounted three guide rollers according to the following combinations:

- **MBL 335-1:** three concentric guide rollers, of which one on the fixing side;
- **MBL 335-2:** three concentric guide rollers, of which two on the fixing side;
- **MBLR 335-1:** three concentric guide rollers, of which one on the fixing side;
- **MBLR 335-2:** three concentric guide rollers, of which two on the fixing side.

**MBL 335-..** carriages are dissymmetrical components. In order to fully utilize the load capacity of the carriages it is necessary to consider the main load direction and than put the two coupled guide rollers in that direction.

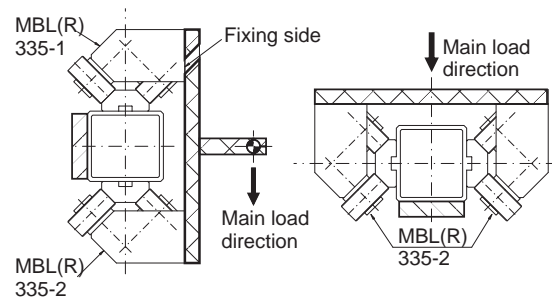

MBL components are checked with the same method used for ROLBLOC BL, but it is very important to consider the exact bearing ratings that must be correct for the load direction. When the axial load (perpendicular to the fixing side of the carriage, or parallel to the fixing side of the rail) is in the direction of the two coupled guide rollers, as for the sketch above, you must use the coefficient with the suffix 2 ( $F_{a2}$ ,  $Y_2$ ), otherwise with the suffix 1 ( $F_{a1}$ ,  $Y_1$ ).

### Mounting instructions

For the mounting of the carriages BL or MBL, with two, three and four guide rollers, are necessary at least two carriages on every rail. A slider realised with only two carriages for rail is not steady (see sketch below).

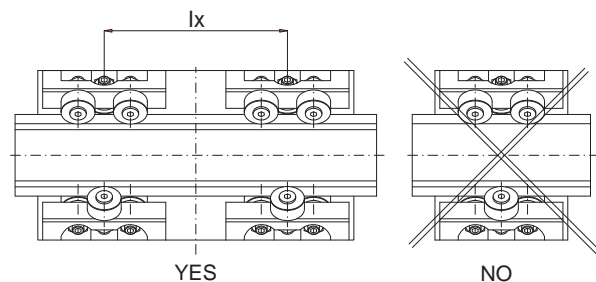

Pay the maximum attention during the setting of the eccentricity of the eccentric guide rollers in order to avoid excessive preloads that can reduce the lifetime of the system. Setting the eccentric guide rollers by rotating the stud anticlockwise (respect the head side of the guide roller).

## Guide rails GU..M, GU..MT

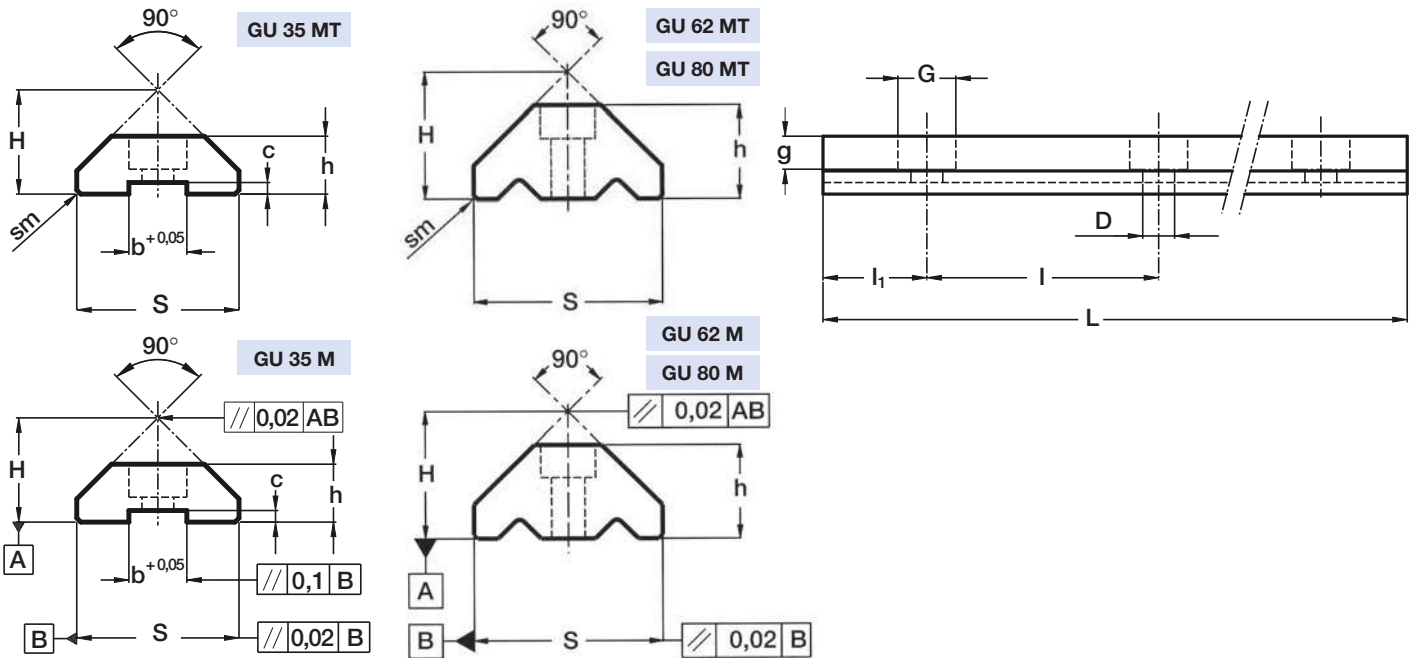

The longitudinal slot of rail GU 35 permits using reference elements SAG for guide positioning.

Type	Dimensions (mm)											Weight (kg/m) <sup>(2)</sup>
	H ± 0.05	h ± 0.05	S ± 0.05	D + 0.1	G	g	b + 0.05	c ± 0.05	sm	l	l <sub>1</sub>	
<b>GU 35 MT</b>	23.9	15.7	35.5	6.6	11	6.8	10	3.8	1x45°	90	30	3.35
<b>GU 62 MT</b>	43.5	32.5	63.5	11	18	11	-	-	2x45°	120	30	11.80
<b>GU 80 MT<sup>(3)</sup></b>	56.7	41.5	81.5	13.5	20	13	-	-	2x45°	120	30	20.30

max length in single element L = 6 000 mm (1)

Type	Dimensions (mm)											Weight (kg/m) <sup>(2)</sup>
	H ± 0.05	h ± 0.05	S ± 0.05	D + 0.1	G	g	b + 0.05	c ± 0.05	l	l <sub>1</sub>		
<b>GU 35 M</b>	23	15	35	6.6	11	6.8	10	3.3	90	30	3.2	
<b>GU 62 M</b>	42	31	62	11	18	11	-	-	120	30	10.9	
<b>GU 80 M</b>	55.2	40	80	13.5	20	13	-	-	120	30	20	

max length in single element L = 4 020 mm (1)

(1) Longer rails are supplied in sections with ground butt joints - (2) Weight without holes - (3) Max length in single element 5 000 mm for GU 80 MT

### Rails finishing

- drawn, induction hardened and sandblasted tracks (**MT**);
- drawn, induction hardened and ground (**M**)
- induction hardening on raceways only

### Hole layout

- holes according to catalogue (**SB**)
- finishes to drawing (**NZ**)
- without holes (**NF**)

### Optional features

- ground one end (**R**)
- ground both ends (**RR**)
- chemical Nickel-plating (**NW**)

Example of standard designation: **GU 62 MT 4300 SB**

See page 17 for standard codification

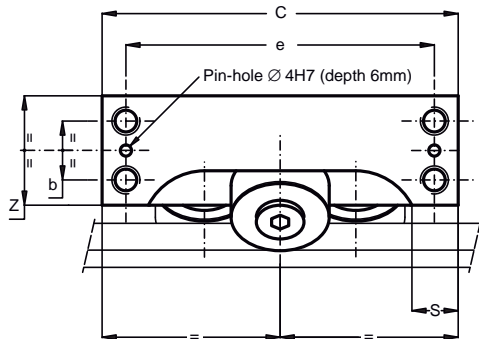
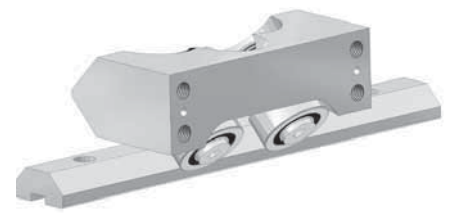

MBL(R) 335-1 (carriage with 1 guide roller on the fixing side)

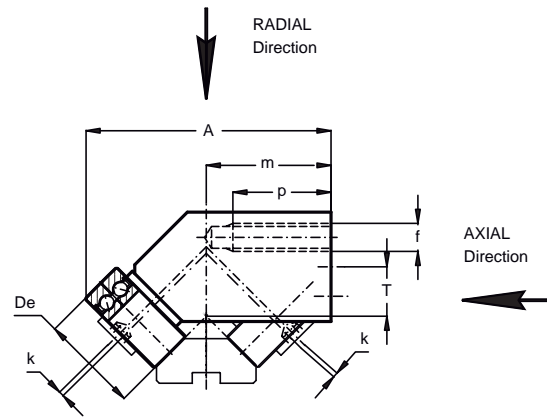

MBL(R) 335-... (carriage with three guide rollers)

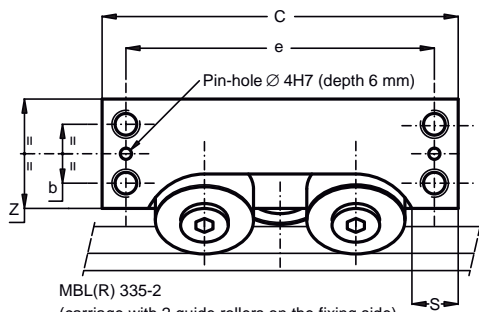

MBL(R) 335-2  
(carriage with 2 guide rollers on the fixing side)

Type		Dimensions (mm)											Weight (kg)	
concentric	eccentric	A	C	S	m	e	b	p	f	k <sup>(2)</sup>	T	Z		De
<b>MBL 335-1</b>	<b>MBLR 335-1</b>	87.5	127	16.5	44.5	110	21	35	M10	0.75	17.6	39	35	0.94
<b>MBL 335-2</b>	<b>MBLR 335-2</b>													

Type		Dynamic load (N)	Limit loads (N)			Life coefficients		
			radial Fr	axial Fa		X	Y	
		C <sub>w</sub> <sup>(3)</sup>		F <sub>a1</sub> <sup>(5)</sup>	F <sub>a2</sub> <sup>(6)</sup>		Y <sub>1</sub> <sup>(5)</sup>	Y <sub>2</sub> <sup>(6)</sup>
<b>MBL 335-1</b>	<b>MBLR 335-1</b>	14 500	7 000	3 500	7 000	1	1	0
<b>MBL 335-2</b>	<b>MBLR 335-2</b>							

1) Standard shields metallic ZZ

2) Maximum value of eccentricity for carriages MBLR, where all the guide rollers are eccentric

3) C<sub>w</sub> basic load for 100 km, radial load

4) Pressure angle  $\alpha$  for load calculation: 45°

5) Bearing ratings you must use when the axial load is in the direction of the side with one guide roller only

6) Bearing ratings you must use when the axial load is in the direction of the side with two guide rollers

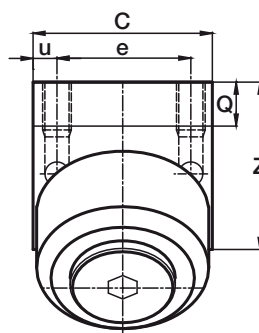
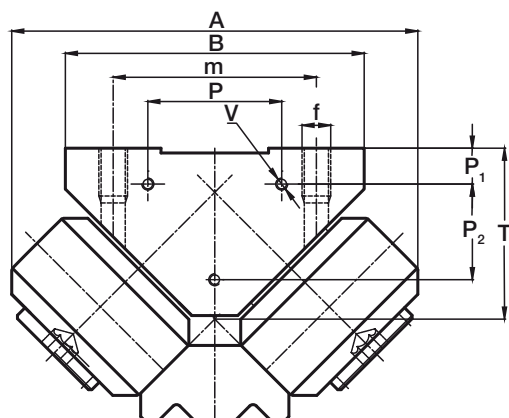
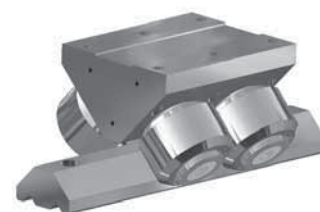

BL 2... two guide rollers block

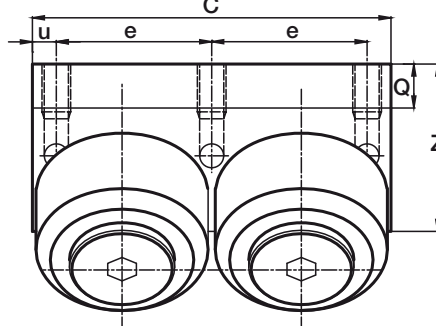

BL 4... four guide rollers block

Type	Dimensions (mm)														Weight (kg)
	A	B	C	P	P <sub>1</sub>	P <sub>2</sub>	V	m	e	u	f	Q	T	Z	
BL 2 52	136	90	56	54	14	16	M4x 7	70	40	8	M 8	12	43	47	2.4
BL 4 520	136	90	112	54	14	16	M4x 7	70	48	8	M 8	12	43	47	4.8
BL 2 75	170	125	76	56	15	40	M5x 8	85	56	10	M 12	17.1	71.5	70	6.5
BL 4 750	170	125	152	56	15	40	M5x 8	85	66	10	M 12	17.1	71.5	70	13
BL 2 115	243	170	125	80	15	70	M5x10	120	95	15	M 14	22	99.8	93	21.6
BL 4 115	243	170	250	80	15	70	M5x10	120	110	15	M 14	22	99.8	93	43.2

Type	Dynamic load (N)	Limit loads (N)		Life coefficients	
	C <sub>w</sub> <sup>(3)</sup>	Radial F <sub>r</sub> <sup>(4)</sup>	Axial F <sub>a</sub> <sup>(5)</sup>	X	Y
BL 2 52	59 000	16 800	8 400	1	1
BL 4 52	118 000	33 600	16 800	1	1
BL 2 75	96 300	44 200	22 100	1	1
BL 4 75	192 600	88 400	44 200	1	1
BL 2 115	264 500	78 600	39 300	1	1
BL 4 115	529 000	157 200	78 600	1	1

1) Standard seals: material NBR, RS type

2) On request, the guide rollers can be supplied in stainless steel (suffix **NX**) and with Viton seals for operating temperatures up to 120°C (suffix **V**, up to dimension BL.... 75 included). Internal rolling elements in standard bearing steel

3) C<sub>w</sub> basic load for 100 km, load perpendicular to the roller side fixing surface

4) Loads perpendicular to the roller side fixing surface

5) Loads parallel to the roller side fixing surface

6) Pressure angle α for loads checking calculation: 45°



## Adjustment plates PR

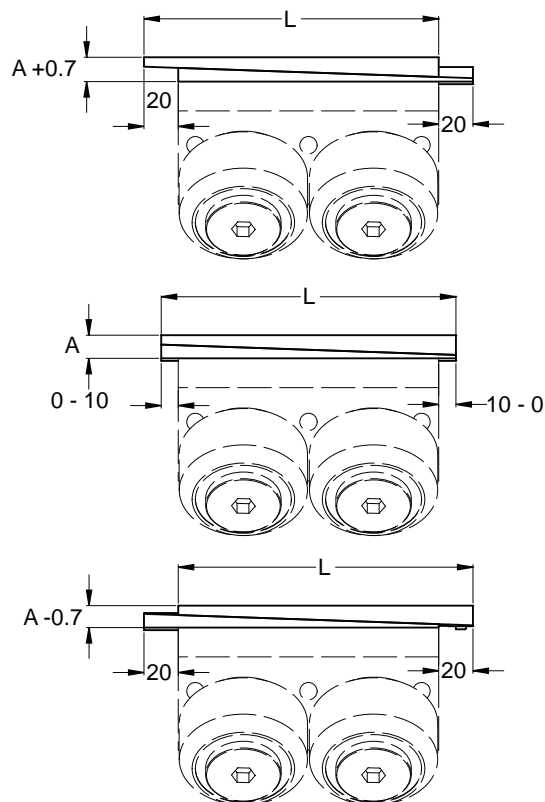
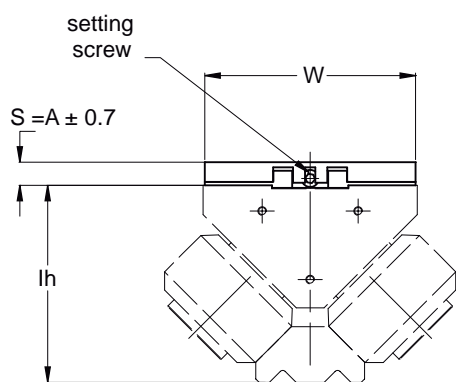

Type	Dimensions (mm)			Weight (kg)	Combination with ROLBLOC carriages
	L	W	A		
PR 252	76	88	13.5	0.5	BL 252
PR 452	132	88	13.5	1.0	BL 452
PR 275	96	123	13.5	1.0	BL 275
PR 475	172	123	13.5	1.9	BL 475
PR 2115	145	168	17	2.9	BL 2115
PR 4115	270	168	17	5.7	BL 4115

The adjusting plates allows to easily set the proper component preload during the mounting on the machine.

The two steel plates are placed in between the standard ROLBLOC and the mounting surface. Setting is done by the setting screw before the final tightening of the screws used to mount the ROLBLOC.

Dimension W of plates is 2 mm lower than the block of ROLBLOC. Use the ROLBLOC side are reference for the block position.

When the plates are set in the mid position (thickness 13.5 mm) they can be shifted 10 mm from the block centreline. The possible shift is reduced with the regulation since it become null at the end of allowed setting, minimum or maximum height. Consider 10 mm of space over the plate length on each side (20 mm over the block length) to use the full thickness setting capability +/- 0,7 mm



**MBL**

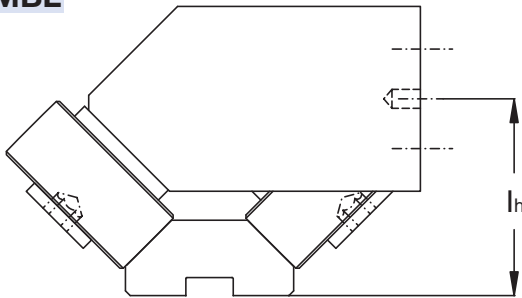

**BL**

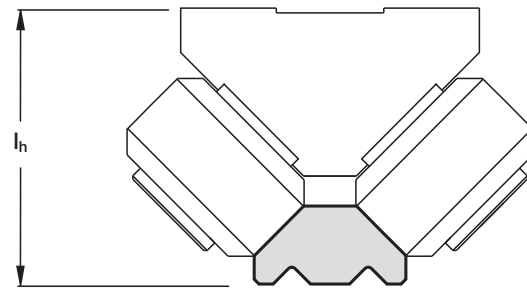

Guide \ Carriage	$l_h$ (mm)						
	MBL / MBLR	BL 2 52	BL 4 52	BL 2 75	BL 4 75	BL 2 115	BL 4 115
GU 35 MT	41.5	-	-	-	-	-	-
GU 35 MT	40.6	-	-	-	-	-	-
GU 62 MT	-	86.5	86.5	115	115	-	-
GU 62 MT	-	85	85	113.5	113.5	-	-
GU 80 MT	-	-	-	-	-	156.5	156.5
GU 80 M	-	-	-	-	-	155	155

## Mounting examples

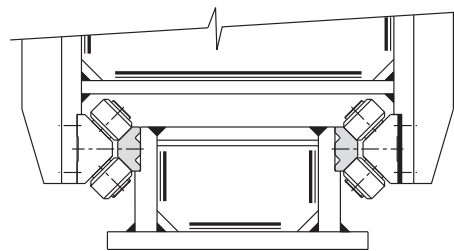
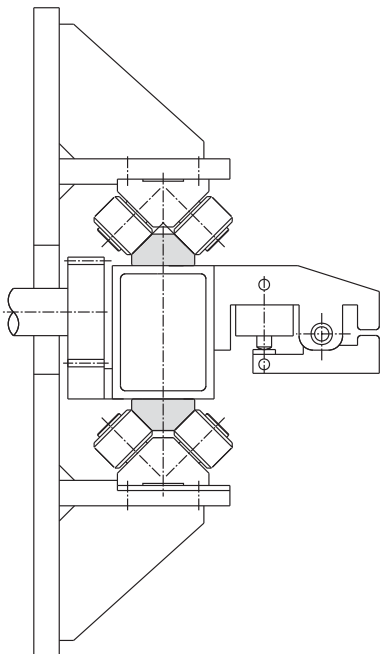

## Mounting example

Palletising equipment

Rolbloc

V-Line

Multi-Motion-Line

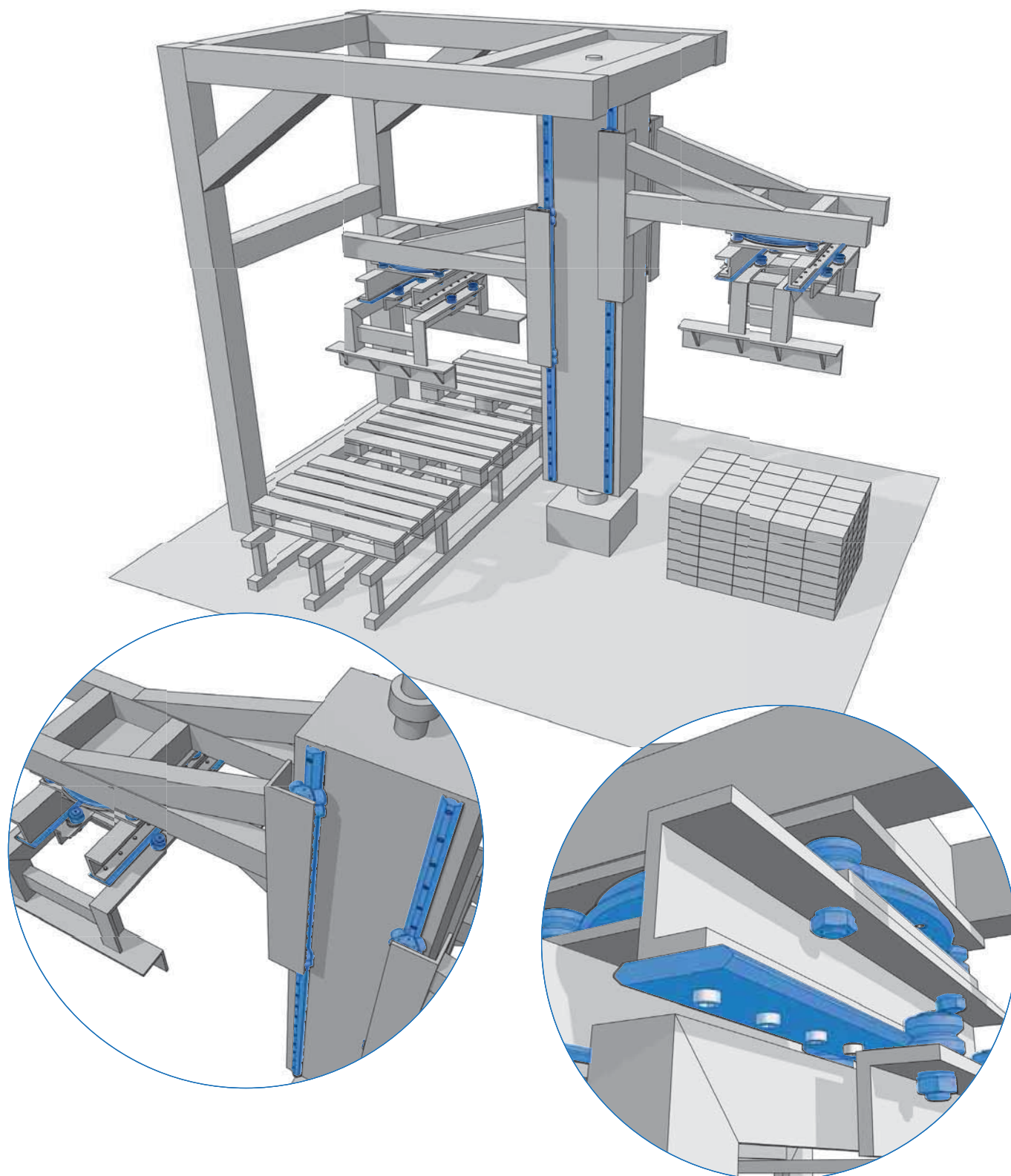

# V-Line

## FS System

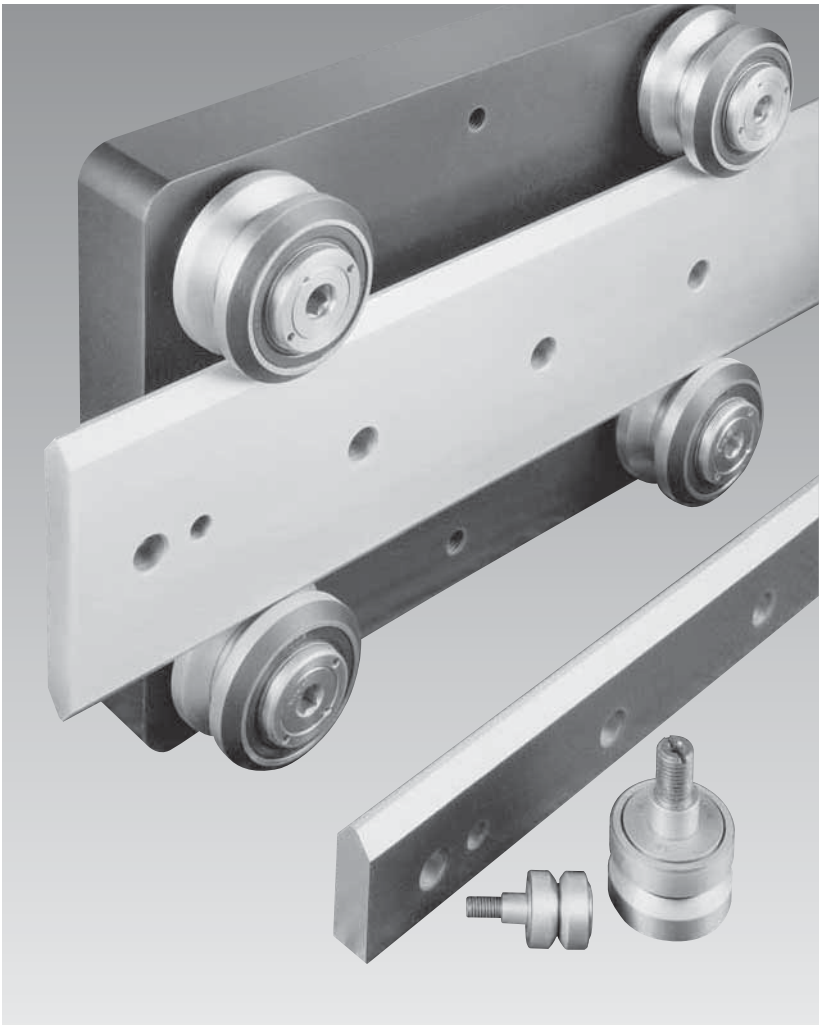

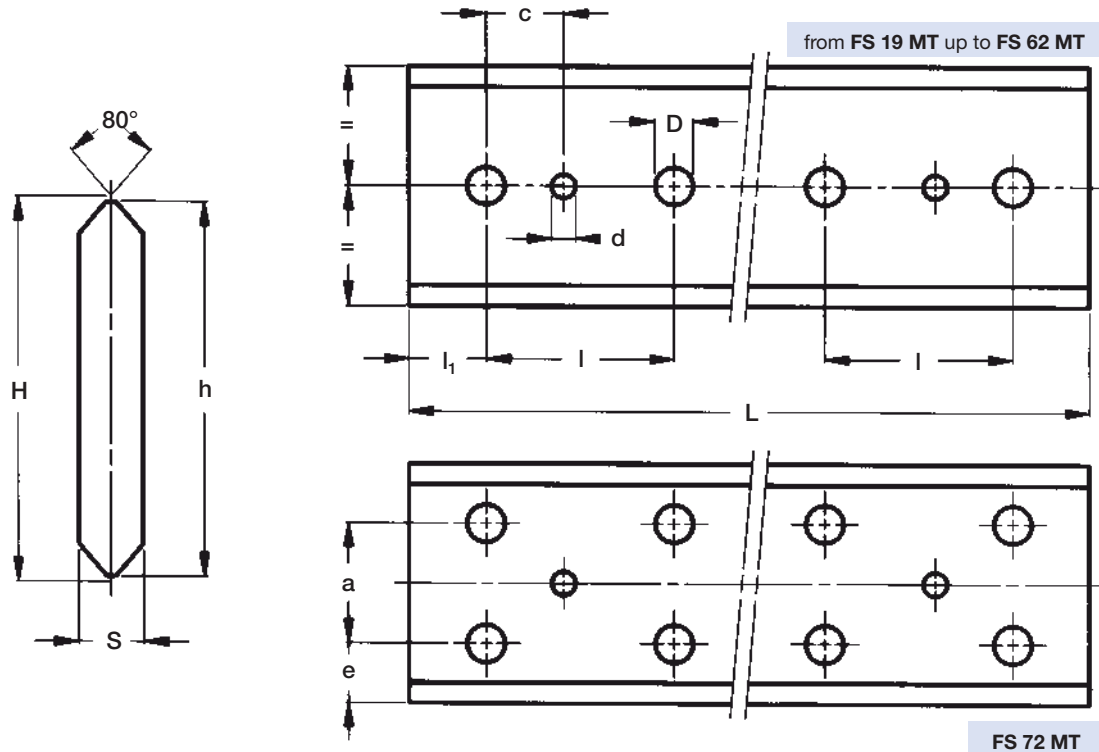

Type	Dimensions (mm)										Weight <sup>(2)</sup> (kg/m)
	H ± 0.1	h ± 0.1	S ± 0.1	d <sup>(3)</sup> + 0.05	D	c <sup>(3)</sup>	e	a	l	l <sub>1</sub>	
FS 19 MT	22.2	21	5.3	4	6.5	15	-	-	90	30	0.8
FS 22 MT	28.8	27	5.8	5	6.5	15	-	-	90	30	1.1
FS 32 MT	43.8	42	6.8	6	6.5	15	-	-	90	30	2.1
FS 35 MT	48.8	47	8.8	6	9	20	-	-	90	30	3.0
FS 40 MT	64.5	62	8.8	6	9	20	-	-	90	30	4.1
FS 47 MT	80.15	77.2	11	6	11.5	20	-	-	90	30	6.3
FS 52 MT	91.35	88.2	13	8	13.5	20	-	-	90	30	8.5
FS 62 MT	106	103	15.7	8	13.5	20	-	-	90	30	11.7
FS 72 MT	124.6	121	19	10	17.5	30	30.5	60	90	30	16.9

Maximum length of single guide element L = 6 000 mm (1)

1) Longer rails are supplied in sections with ground butt joints - 2) Weight without holes

3) Standard layout without pin holes (pin holes only on request)

### Rails finishing

- drawn, induction hardened and sandblasted tracks (**MT**);
- induction hardening on raceways only

### Hole layout

- holes according to catalogue (**SB**)
- finishes to drawing (**NZ**)
- without holes (**NF**)

### Optional features

- ground one end (**R**)
- ground both ends (**RR**)
- chemical Nickel-plating (**NW**)
- pin holes

Example of standard designation: **FS 52 MT 5280 SB**

See page 17 for standard codification

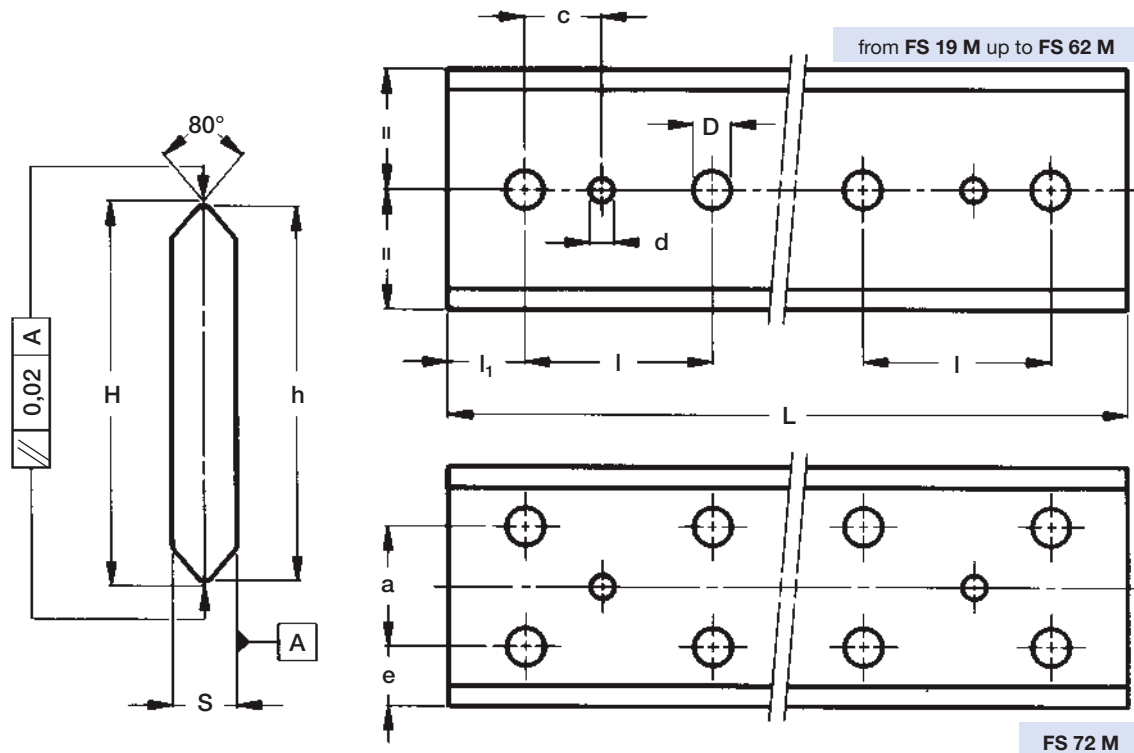

Type	Dimensions (mm)										Weight <sup>(2)</sup> (kg/m)
	H ± 0.05	h ± 0.1	S ± 0.05	d <sup>(3)</sup> + 0.05	D	c <sup>(3)</sup>	e	a	l	l <sub>1</sub>	
FS 19 M	20.95	20	4.5	4	6.5	15	-	-	90	30	0.6
FS 22 M <sup>(4)</sup>	27.86	26	5	5	6.5	15	-	-	90	30	0.9
FS 32 M	42.86	41	6	6	6.5	15	-	-	90	30	1.8
FS 35 M <sup>(4)</sup>	47.86	46	8	6	9	20	-	-	90	30	2.6
FS 40 M	63.58	61	8	6	9	20	-	-	90	30	3.7
FS 47 M <sup>(4)</sup>	78.58	76	10	6	11.5	20	-	-	90	30	5.6
FS 52 M	89.78	87	12	8	13.5	20	-	-	90	30	7.7
FS 62 M	104.76	102	15	8	13.5	20	-	-	90	30	11.2
FS 72 M	122.98	120	18	10	17.5	30	30	60	90	30	15.8

Maximum length of single guide element L = 4 020 mm (1)

1) Longer rails are supplied in sections with ground butt joints - 2) Weight without holes

3) Standard layout without pin holes (pin holes only on request) - (4) Size 22, 35 and 47 available in stainless steel (NX)

### Rails finishing

- drawn, induction hardened and ground profile (**M**);
- induction hardening on raceways only

### Hole layout

- holes according to catalogue (**SB**)
- finishes to drawing (**NZ**)
- without holes (**NF**)

### Optional features

- stainless steel (**NX**) <sup>(4)</sup>
- ground one end (**R**)
- ground both ends (**RR**)
- chemical Nickel-plating (**NW**)
- pin holes

Example of standard designation: **FS 40 M 2760 SB**

See page 17 for standard codification

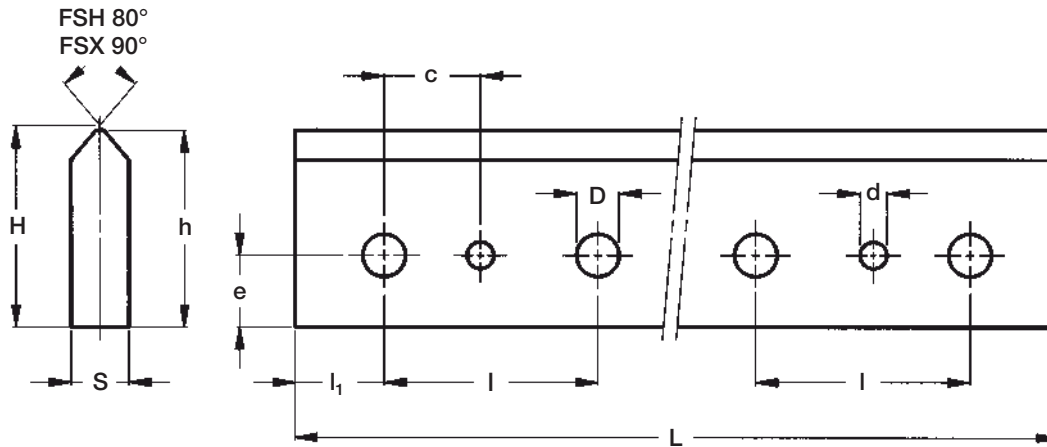

Type	Dimensions (mm)									Weight <sup>(2)</sup> (kg/m)
	H ± 0.1	h ± 0.1	S ± 0.1	d <sup>(3)</sup> + 0.05	D	c <sup>(3)</sup>	e	l	l <sub>1</sub>	
<b>FSH 22 MT</b>	23.9	23	5.8	5	6.5	15	9	90	30	1.0
<b>FSH 32 MT</b>	29.9	29	6.8	6	6.5	15	11	90	30	1.5
<b>FSH 40 MT</b>	37.2	36	8.8	6	9	20	16	90	30	2.4
<b>FSH 52 MT</b>	40.75	39.2	13	8	13.5	20	17	90	30	3.7
<b>FSH 62 MT</b>	50.75	49.2	16	8	13.5	20	17	90	30	5.7
<b>FSH 72 MT</b>	60.85	59.2	19	10	17.5	30	20	90	30	8.2
<b>FSX 90 MT</b>	62.85	61	26.5	10	13.5	30	22	90	30	11.6

Maximum length of single guide element L = 6 000 mm<sup>(1)</sup>

1) Longer rails are supplied in sections with ground butt joints - 2) Weight without holes

3) Standard layout without pin holes (pin holes only on request)

### Rails finishing

- drawn, induction hardened and sandblasted tracks (**MT**);
- induction hardening on raceways and base only

### Hole layout

- holes according to catalogue (**SB**)
- finishes to drawing (**NZ**)
- without holes (**NF**)

### Optional features

- ground one end (**R**)
- ground both ends (**RR**)
- chemical Nickel-plating (**NW**)
- pin holes

Example of standard designation: **FSH 52 MT 5280 SB**

See page 17 for standard codification

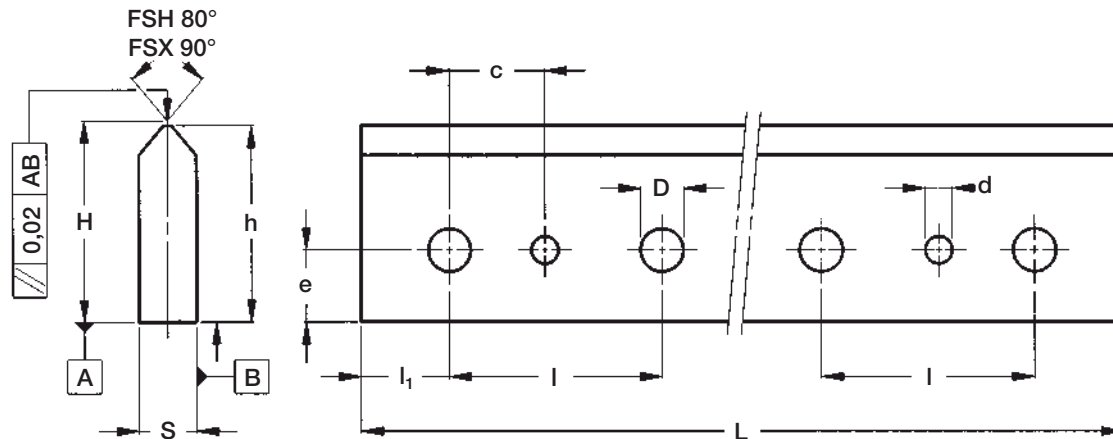

Type	Dimensions (mm)									Weight <sup>(2)</sup> (kg/m)
	H ± 0.05	h ± 0.1	S ± 0.05	d <sup>(3)</sup> + 0.05	D	c <sup>(3)</sup>	e	I	I <sub>1</sub>	
<b>FSH 19 M</b>	18.98	18.5	4.5	4	6.5	15	8	90	30	0.6
<b>FSH 22 M</b>	22.93	22	5	5	6.5	15	9	90	30	0.8
<b>FSH 32 M</b>	28.93	28	6	6	6.5	15	11	90	30	1.2
<b>FSH 40 M</b>	36.29	35	8	6	9	20	16	90	30	2.1
<b>FSH 52 M</b>	39.39	38	12	8	13.5	20	17	90	30	3.4
<b>FSH 62 M</b>	49.38	48	15	8	13.5	20	17	90	30	5.2
<b>FSH 72 M</b>	59.49	58	18	10	17.5	30	20	90	30	7.6
<b>FSX 90 M</b>	61.79	60	26	10	13.5	30	22	90	30	11.0

Maximum length of single guide element L = 4 020 mm<sup>(1)</sup>

1) Longer rails are supplied in sections with ground butt joints - 2) Weight without holes

3) Standard layout without pin holes (pin holes only on request)

### Rails finishing

- drawn, induction hardened and ground profile (**M**);
- induction hardening on raceways and base only

### Hole layout

- holes according to catalogue (**SB**)
- finishes to drawing (**NZ**)
- without holes (**NF**)

### Optional features

- ground one end (**R**)
- ground both ends (**RR**)
- chemical Nickel-plating (**NW**)
- pin holes

Example of standard designation: **FSH 40 M 2760 SB**

See page 17 for standard codification

## Guide rollers FR..EU

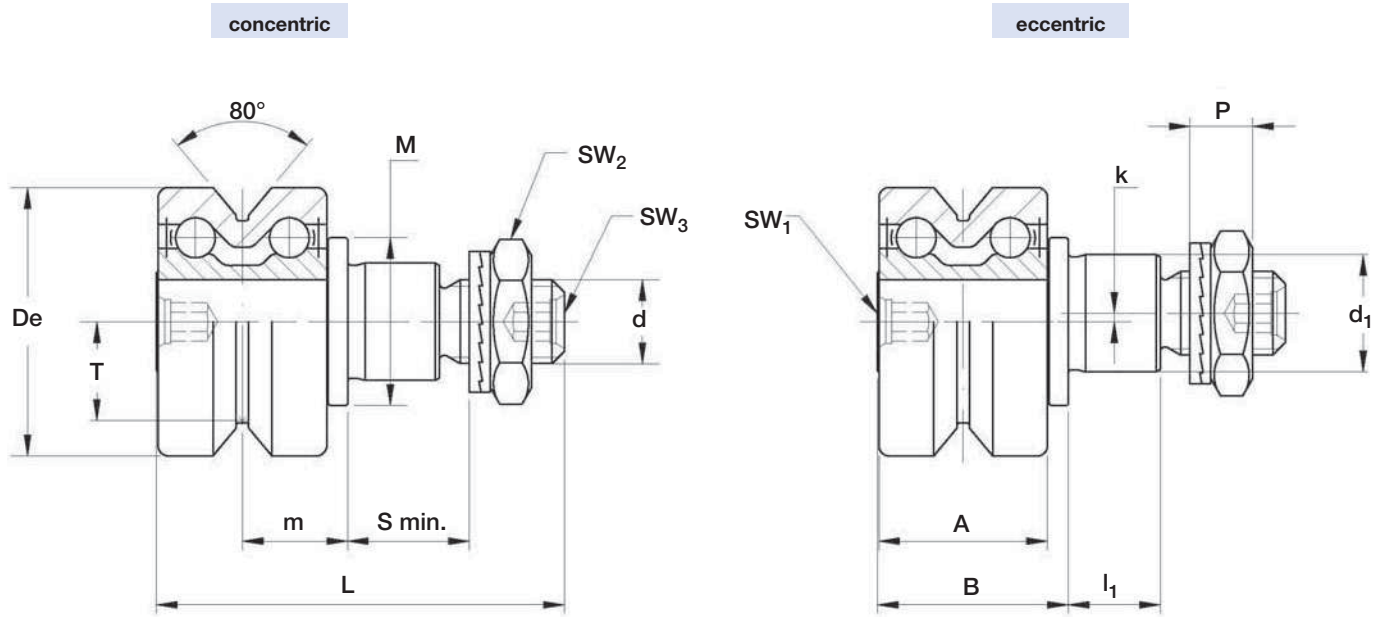
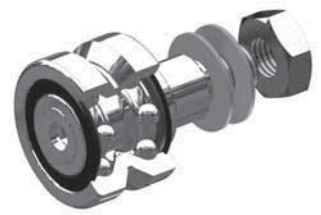

The sides of the race are slightly convex

Type		Dimensions (mm)															
concentric	eccentric	De	d <sub>1</sub> <sup>(1)</sup>	d	T	m	S <sub>min</sub>	P	L	A	B	I <sub>1</sub>	M	SW <sub>1</sub>	SW <sub>2</sub>	SW <sub>3</sub>	k
FR 22 EU <sup>(4)</sup>	FRR 22 EU <sup>(4)</sup>	22	9	M 6 x 1	7.7	9.4	9	6.5	36.8	15	18	8	14	4	10	3	0.8
FR 32 EU <sup>(4)</sup>	FRR 32 EU <sup>(4)</sup>	32	14	M 10 x 1.25	11.8	12.6	12	8.5	48.9	20.2	22.9	11	20	4	17	4	1
FR 40 EU <sup>(4)</sup>	FRR 40 EU <sup>(4)</sup>	40	16	M 12 x 1.5	14.6	15.5	12	10.4	58.5	25	29.5	11	22	5	19	5	1
FR 52 EU	FRR 52 EU	52	21	M 16 x 1.5	19.1	19.8	15	11.4	69.5	32	36.5	14	28	6	24	6	1.5
FR 62 EU	FRR 62 EU	62	27	M 20 x 1.5	22.1	20.8	18.5	12.4	80	33.6	39	17.5	35	8	30	8	2

Type		Dynamic load (N)	Limit loads (N)		Life coefficients		Torque wrench settings <sup>(2)</sup> (Nm)	Weight (g)
			radial F <sub>r</sub>	axial F <sub>a</sub>	X	Y		
FR 22 EU	FRR 22 EU	2 900	1 400	420	1	2	3	45
FR 32 EU	FRR 32 EU	5 800	2 000	800	1	1.9	20	125
FR 40 EU	FRR 40 EU	8 500	3 650	1 400	1	1.9	26	230
FR 52 EU	FRR 52 EU	11 700	8 500	3 000	1	1.9	64	510
FR 62 EU	FRR 62 EU	13 900	11 000	3 500	1	1.9	120	765

1) Housing bore tolerance: H7

2) The torque wrench settings are given for non-lubricated threads; for lubricated threads, multiply figure by 0.8

3) C<sub>w</sub> basic load for 100 km

4) FR/R 22, 32, 40 are available in stainless steel (NX)

The guide rollers are complete with self-locking washers and hexagonal nut (DIN439B) for fitting

Pressure angle  $\alpha$  for load calculation: 40°

NBR seals RS type

## Guide Rollers FR..EU AS, FR..EU AZ

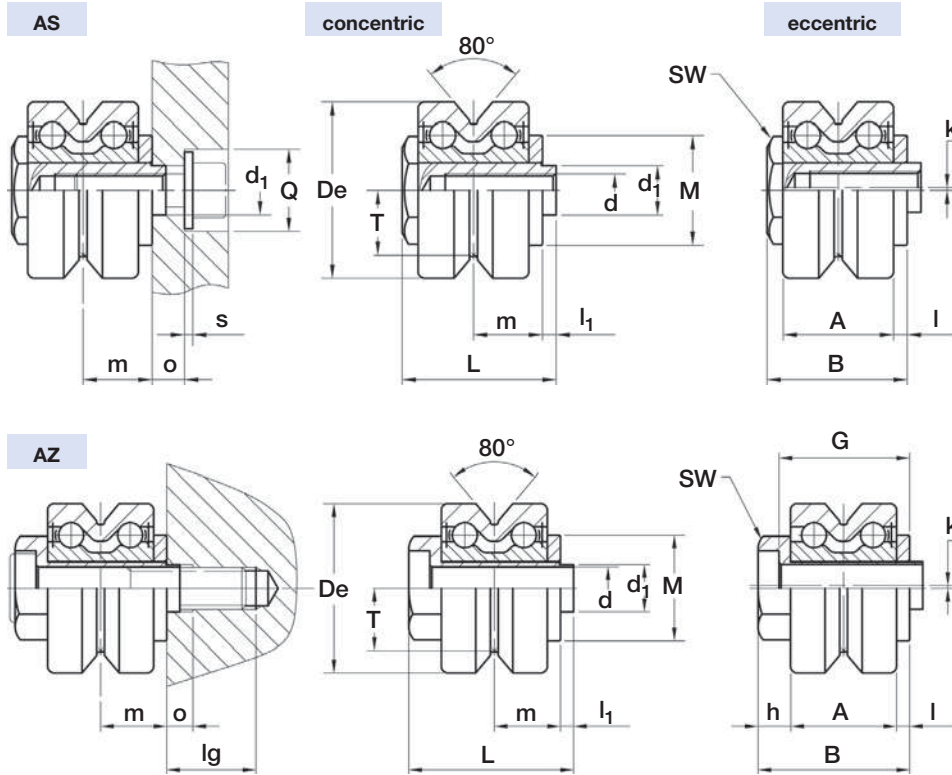
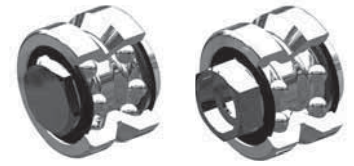

Type		Dimensions (mm)																		
concentric	eccentric	De	d1 <sup>(1)</sup>	d <sup>(2)</sup>	T	m	L	A	B	l <sub>1</sub>	I	h	M	SW	G	o	Q	lg <sup>(7)</sup>	s	k
FR 22 EU AS <sup>(6)</sup>	FRR 22 EU AS <sup>(6)</sup>	22	6	M 5	7.7	9.4	21.8	15	19.8	2	1.9	-	14	10	-	4.5	10	-	0	0.5
FR 32 EU AS <sup>(6)</sup>	FRR 32 EU AS <sup>(6)</sup>	32	9	M 6	11.8	12.6	28.1	20.2	25.6	2.5	2.5	-	20	17	-	6	15	-	1.5 <sup>(4)</sup>	0.5
FR 40 EU AS <sup>(6)</sup>	FRR 40 EU AS <sup>(6)</sup>	40	11	M 8	14.6	15.5	33.5	25	31	2.5	3	-	22	22	-	6.5	20	-	2 <sup>(4)</sup>	1
FR 52 EU AS	FRR 52 EU AS	52	16	M10	19.1	19.8	43.2	32	40	3.2	3.8	-	28	27	-	8	24	-	2.5 <sup>(4)</sup>	1.5
FR 62 EU AS	FRR 62 EU AS	62	19	M12	22.1	20.8	46	33.6	41.8	4.2	4	-	35	30	-	9	26	-	2.5 <sup>(5)</sup>	1.5
FR 22 EU AZ <sup>(6)</sup>	FRR 22 EU AZ <sup>(6)</sup>	22	6	5.1	7.7	9.4	23.9	15	21.9	2	1.9	5	14	11	18.9	4	-	13	-	0.5
FR 32 EU AZ <sup>(6)</sup>	FRR 32 EU AZ <sup>(6)</sup>	32	9	8.1	11.8	12.6	31.4	20.2	28.9	2.5	2.5	6.2	20	17	24.9	5	-	17	-	0.5
FR 40 EU AZ <sup>(6)</sup>	FRR 40 EU AZ <sup>(6)</sup>	40	11	10.1	14.6	15.5	38	25	35.5	2.5	3	7.5	22	22	30.5	5	-	26	-	0.8
FR 52 EU AZ	FRR 52 EU AZ	52	16	14.1	19.1	19.8	49.5	32	46.3	3.2	3.8	10.5	28	27	39.3	5.5	-	27	-	1.5
FR 62 EU AZ	FRR 62 EU AZ	62	19	16.1	22.1	20.8	54.5	33.6	50.3	4.2	4	12.7	35	32	42.3	6.5	-	30	-	1.5

Guide roller size	Dynamic load (N)	Limit loads (N)		Life coefficients		Weight AS (g)	Weight AZ (g)	On request for AZ screw DIN7984
	Cw <sup>(3)</sup>	radial F <sub>r</sub>	axial F <sub>a</sub>	X	Y			
22	2 900	470	210	1	2	33	31	M 5 x 30
32	5 800	1 590	710	1	1.9	95	93	M 8 x 40
40	8 500	2 120	940	1	1.9	173	173	M10 x 50
52	11 700	5 830	2 560	1	1.9	374	365	M14 x 60
62	13 900	9 200	3 500	1	1.9	582	587	M16 x 65

1) Housing bore tolerance: H7

2) Safety threads SPIRALOCK

3) Cw basic load for 100 km

4) Guide roller with washers DIN134 without screw DIN7984 or DIN912

5) Guide roller with washers DIN125 without screw DIN7984 or DIN912

6) FR/R 22, 32, 40 AS and AZ are available in stainless steel (NX)

7) AZ: minimum length of the thread engaged

steel = 1 x d - cast iron = 1.25 x d

aluminium = 2 x d

AS screws length: min = d+o+s; max = m+4+o+s

NBR seals RS type

Pressure angle  $\alpha$  for load calculation: 40°

## Guide rollers FRN..EI

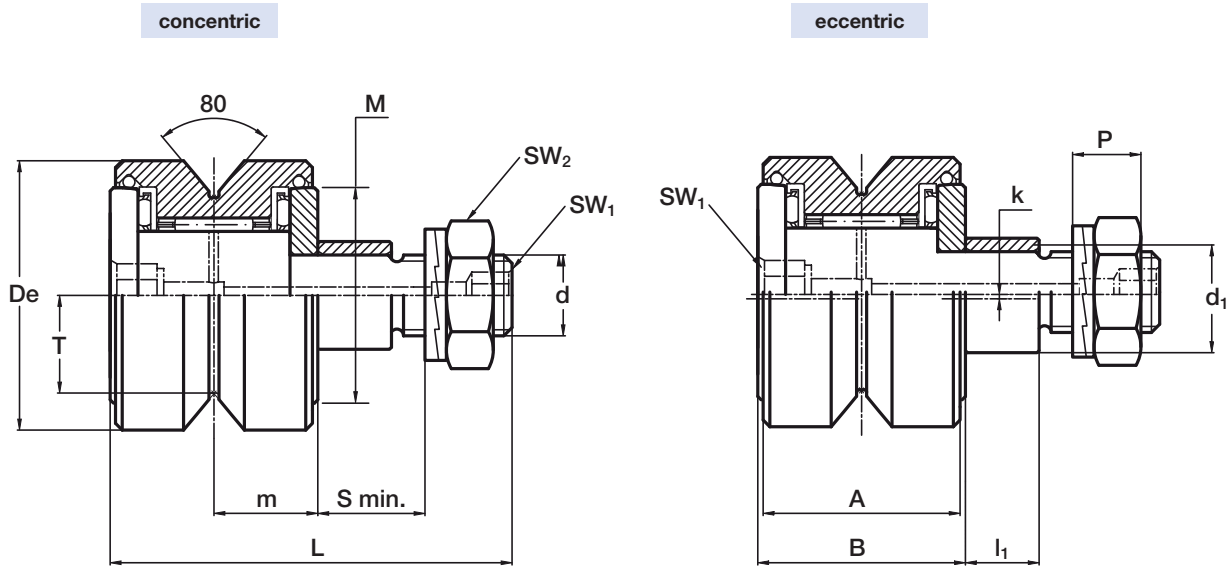

The sides of the race are slightly convex

Type		Dimensions (mm)														
concentric	eccentric	De	d <sub>1</sub> <sup>(1)</sup>	d	T	m	S min.	P	L	A	B	l <sub>1</sub>	M	SW <sub>1</sub>	SW <sub>2</sub>	k
<b>FRN 19 EI</b> <sup>(8)</sup>	<b>FRNR 19 EI</b> <sup>(8)</sup>	19	7	M 5 x 0.8	7	8.8	6.5	4.2	34	17	18	5.5	14	(10)	8	0.5
<b>FRN 22 EI</b> <sup>(8)</sup>	<b>FRNR 22 EI</b> <sup>(8)</sup>	22	9	M 6 x 1	7.7	9.4	9	6.5	39	18.2	20	8	16.5	(10)	10	0.5
<b>FRN 32 EI</b> <sup>(8)</sup>	<b>FRNR 32 EI</b> <sup>(8)</sup>	32	14	M 10 x 1.25	11.8	12.6	12	10.4	52	24.2	26	11	25	4	17	1
<b>FRN 40 EI</b> <sup>(9)</sup>	<b>FRNR 40 EI</b> <sup>(9)</sup>	40	16	M 12 x 1.5	14.6	15.5	12	11.4	60	29.4	31	11	32	8	18	1

Type		Dynamic loads (N)		Limit loads (N)		Torque wrench <sup>(2)</sup> settings (Nm)	Weight (g)
		C <sub>wr</sub> <sup>(4)</sup>	C <sub>wa</sub> <sup>(4)</sup>	radial F <sub>r</sub>	axial F <sub>a</sub>		
<b>FRN 19 EI</b>	<b>FRNR 19 EI</b>	1 800	600	490	270	1.8	35
<b>FRN 22 EI</b>	<b>FRNR 22 EI</b>	3 280	800	590	290	3	53
<b>FRN 32 EI</b>	<b>FRNR 32 EI</b>	5 600	2 100	2 030	950	20	160
<b>FRN 40 EI</b>	<b>FRNR 40 EI</b>	12 300	2 600	2 800	1 350	26	290

1) Housing bore tolerance: H7

2) The torque wrench settings are given for non-lubricated threads; for lubricated threads, multiply figure by 0.8

3) On request, the guide rollers can be supplied with external parts in stainless steel (suffix **NX**). Internal rolling elements in standard bearing steel.

4) C<sub>w</sub> basic load for 100 km

5) The guide rollers are complete with self-locking washers and hexagonal nut (DIN 439B) for fitting

6) Pressure angle  $\alpha$  for load calculation: 40°

7) Standard Viton seals to fit temperature up to 120°C

8) Lubrication hole only on head side

9) Lubrication hole also on stud side

10) For size 19 and 22: screw driver slot on the head and hexagonal socket at the threaded end of the stud

## Guide rollers RKY.., RKX..

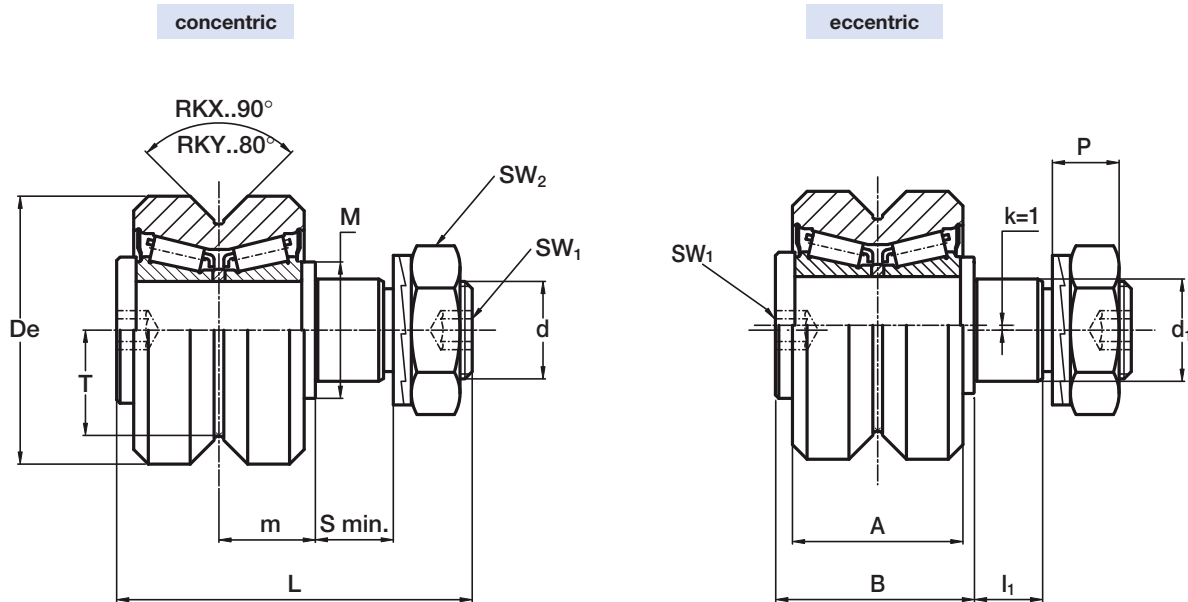

The sides of the race are convex with radius  $R = 400$ .

Type		Dimensions (mm)														
concentric	eccentric	De	d <sub>1</sub> <sup>(1)</sup>	d	T	m	S min.	P	L	A	B	l <sub>1</sub>	M	SW <sub>1</sub>	SW <sub>2</sub>	k
RKY 52	RKYR 52	52	21	M 20 x 1.5	19.1	19.8	15	13.4	73	35	41	14	28	8	30	1
RKY 62	RKYR 62	62	27	M 24 x 1.5	22.1	20.8	19	15.4	83	37	44	18	35	10	36	1
RKY 72	RKYR 72	72	36	M 30 x 1.5	25.5	27	19	21.6	100	45	55	18	44	12	46	1
RKX 90C	RKXR 90C	90	38	M 36 x 1.5	32.5	30	24	24.6	115	53	62	23	50	14	55	1
RKX 110C	RKXR 110C	110	42	M 36 x 1.5	39.5	34	33	24.6	135	60	70	32	56	14	55	1

Type		Dynamic load (N)	Limit loads (N)		Life coefficients		Torque wrench <sup>(2)</sup> settings (Nm)	Weight (kg)
		C <sub>w</sub> <sup>(5)</sup>	radial F <sub>r</sub>	axial F <sub>a</sub>	X	Y		
RKY 52	RKYR 52	40 750	11 900	4 250	1	3.38	80	0.6
RKY 62	RKYR 62	46 000	22 100	6 800	1	3.13	160	0.9
RKY 72	RKYR 72	64 850	31 300	10 100	1	2.96	300	1.6
RKX 90C	RKXR 90C	113 400	43 700	12 600	1	3.42	450	2.8
RKX 110C	RKXR 110C	177 500	55 600	17 900	1	3.40	450	4.9

1) Housing bore tolerance: H7

2) The torque wrench settings are given for non-lubricated threads; for lubricated threads, multiply figure by 0.8

3) Standard seals: material NBR, RS type

4) On request, the guide rollers can be supplied with external parts in stainless steel (suffix **NX**) and with Viton seals for operating temperatures up to 120°C (suffix **V**, up to dimension RKX 90 C included). Internal rolling elements in standard bearing steel

5) C<sub>w</sub> basic load for 100 km

6) Dimensions relating to the stainless-steel rollers (suffix **NX**)

7) The guide rollers are complete with self-locking washers and hexagonal nut (DIN 439B) for fitting

8) Pressure angle  $\alpha$  for load calculation: guide rollers RKY 40° - guide rollers RKX 45°

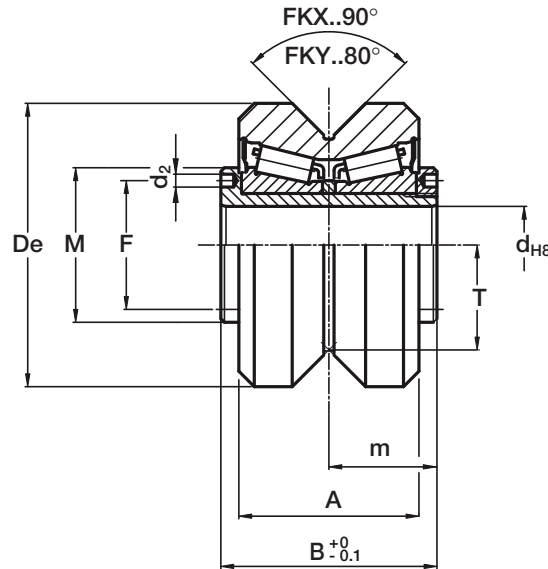

The sides of the race are convex.

Type	Dimensions (mm)									Weight (kg)
	De	d	T	m	A	B	F	d <sub>2</sub>	M	
<b>FKY 52C</b>	52	15	19.1	21	35	42	25	2.5	30	0.5
<b>FKY 62C</b>	62	20	22.1	22.5	37	45	29	3	35	0.6
<b>FKY 72C</b>	72	25	25.5	28	45	56	37	4	44	1.2
<b>FKX 90C</b>	90	28	32.5	32	53 / 56 <sup>(2)</sup>	64	42	4	49	2.3
<b>FKX 110C</b>	110	35	39.5	36	60 / 63 <sup>(2)</sup>	72	52	4	59	3.9

Type	Dynamic load (N)	Limit loads (N)		Life coefficients	
	C <sub>w</sub> <sup>(3)</sup>	radial F <sub>r</sub>	axial F <sub>a</sub>	X	Y
<b>FKY 52C</b>	40 750	11 900	4 250	1	3.38
<b>FKY 62C</b>	46 000	22 100	6 800	1	3.13
<b>FKY 72C</b>	64 850	31 300	10 100	1	2.96
<b>FKX 90C</b>	113 400	43 700	12 600	1	3.42
<b>FKX 110C</b>	177 550	55 600	17 900	1	3.40

1) On request, the guide rollers can be supplied with external parts in stainless steel (suffix **NX**) and with Viton seals for operating temperatures up to 120°C (suffix **V**, up to dimension FKX 90 C included). Internal rolling elements in standard bearing steel

2) Dimensions relating to the stainless-steel rollers (suffix **NX**)

3) C<sub>w</sub> basic load for 100 km

4) To prevent rotation between roller and shaft a pin can be fitted in one of the holes “d<sub>2</sub>” positioned in the side flange

5) Pressure angle α for load calculation: guide rollers FKY 40° - guide rollers FKX 45°

6) Standard seals: material NBR, RS type

## Floating guide rollers FRL..EU

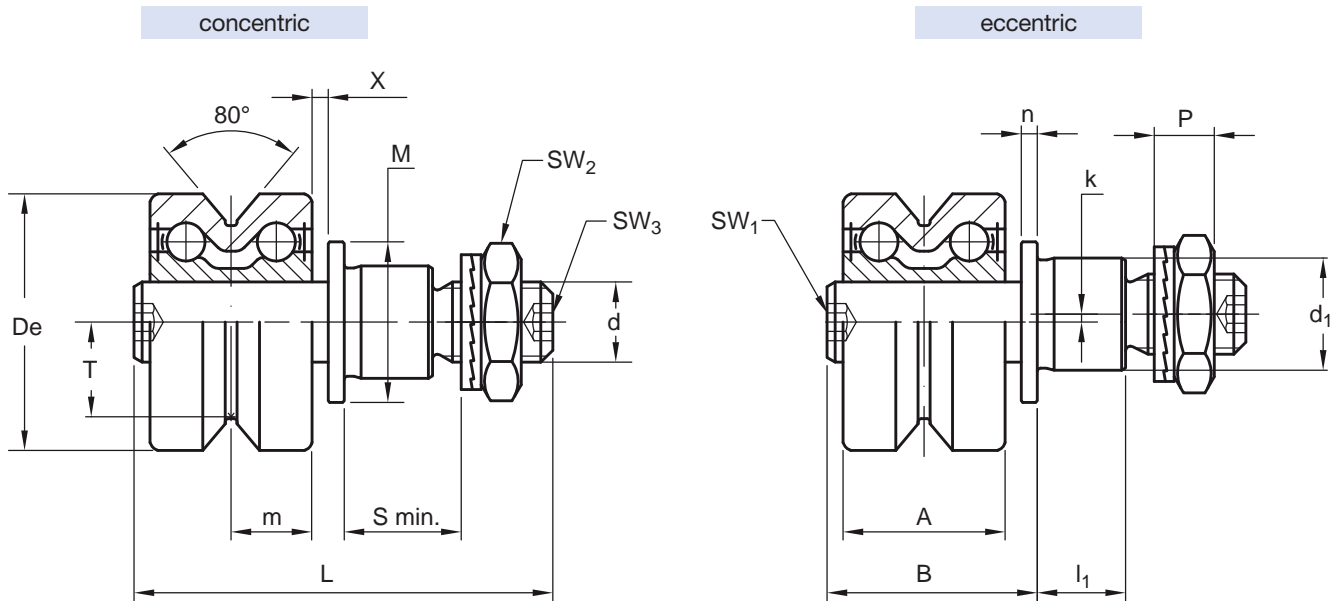
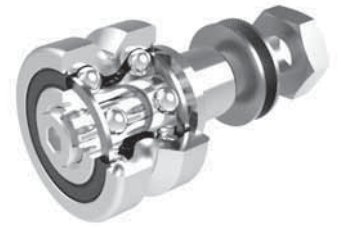

The race ways are slightly convex

Type		Dimensions (mm)																	
concentric	eccentric	De	d <sub>1</sub> <sup>1)</sup>	d	T	m	S <sub>min</sub>	P	L	A	B	I <sub>1</sub>	M	n	X	SW <sub>1</sub>	SW <sub>2</sub>	SW <sub>3</sub>	k
<b>FRL 22 EU</b> <sup>5)</sup>	<b>FRLR 22 EU</b> <sup>5)</sup>	22	9	M6 x 1.0	7.7	7.5	9	6.5	39.3	15.0	20.5	8.0	14.0	1.5	2	4	10	3	0.8
<b>FRL 32 EU</b> <sup>5)</sup>	<b>FRLR 32 EU</b> <sup>5)</sup>	32	14	M10 x 1.25	11.8	10.1	12	8.5	52.2	20.2	26.2	11.0	20.0	2	2	4	17	4	1.0
<b>FRL 40 EU</b> <sup>5)</sup>	<b>FRLR 40 EU</b> <sup>5)</sup>	40	16	M12 x 1.5	14.6	12.5	12	10.4	61.4	25.0	32.4	11.0	22.0	2.4	2.5	5	19	5	1.0
<b>FRL 52 EU</b>	<b>FRLR 52 EU</b>	52	21	M16 x 1.5	19.1	16.0	15	11.4	74	32.0	41.0	14.0	28.0	3	3	6	24	6	1.5
<b>FRL 62 EU</b>	<b>FRLR 62 EU</b>	62	27	M20 x 1.5	22.1	16.8	18.5	12.4	83.6	33.6	42.6	17.5	35.0	3	3	8	30	8	2.0

Type		Dynamic load (N)	Limit load (N)	Limit load Inox version (N) NX	Torque wrench setting <sup>2)</sup> (Nm)	Weight (g) <sup>3)</sup>
		C <sub>w</sub> <sup>4)</sup>	radial F <sub>r</sub>	radial F <sub>r</sub>		
<b>FRL 22 EU</b>	<b>FRLR 22 EU</b>	2900	1050	980	3	46
<b>FRL 32 EU</b>	<b>FRLR 32 EU</b>	5800	1700	1550	20	127
<b>FRL 40 EU</b>	<b>FRLR 40 EU</b>	8500	3000	2750	26	233
<b>FRL 52 EU</b>	<b>FRLR 52 EU</b>	11700	7600	6850	64	520
<b>FRL 62 EU</b>	<b>FRLR 62 EU</b>	13900	11000	10300	120	776

1) Housing bore tolerance: H7

2) The torque wrench settings are given for non-lubricated threads; for lubricated threads multiply figure by 0.8

3) Weight without fittings

4) C<sub>w</sub> = Basic load for 100 Km

5) Dimensions for stainless steel (NX) version

Standard seals: material NBR, RS type

Guide rollers include self-locking washers and hexagonal nut (DIN 439B)

Pressure angle  $\alpha$  for load calculation: 40°



## Floating guide rollers RKXL, RKYL

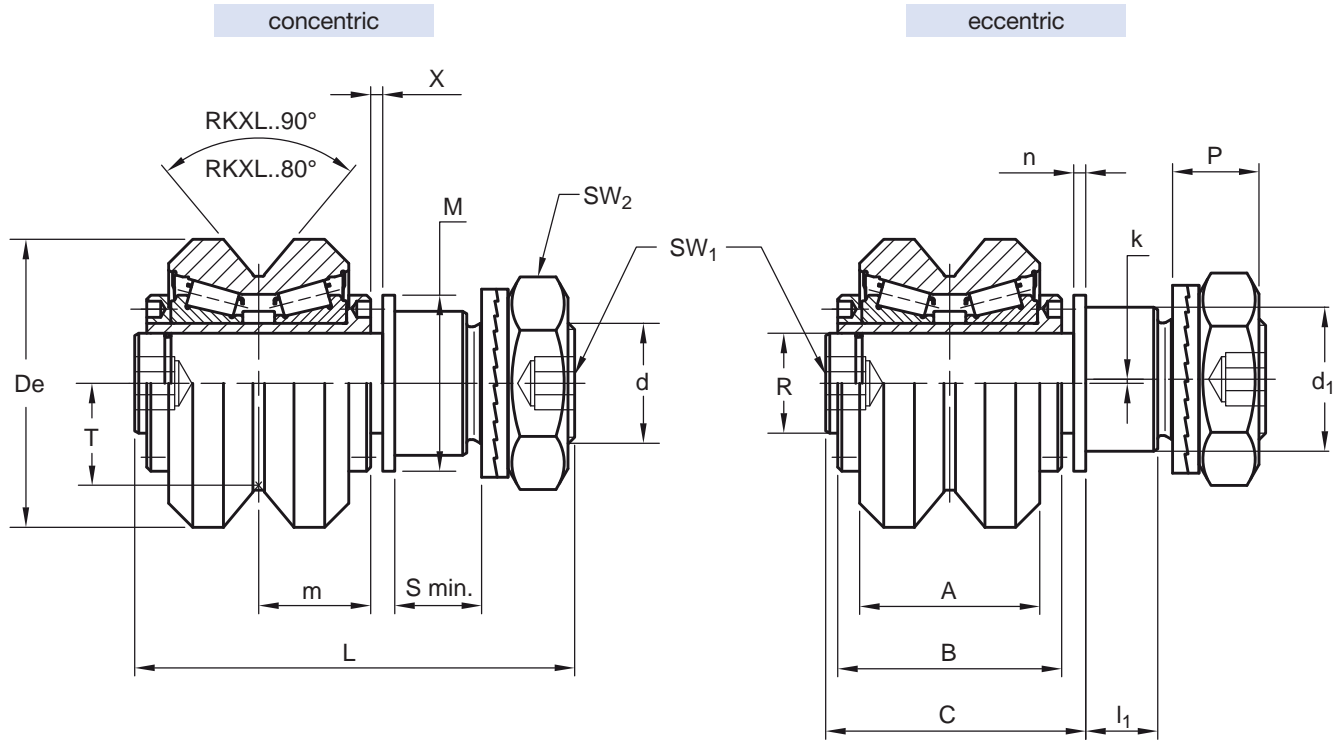

Type		Dimensions (mm)																		
concentric	eccentric	De	d <sub>1</sub> <sup>1)</sup>	d	T	m	± X	S <sub>min</sub>	P	L	A	B	C	l <sub>1</sub>	M	n	SW <sub>1</sub>	SW <sub>2</sub>	k	
<b>RKYL 52</b>	<b>RKYL 52</b>	52	21	M 20 x 1.5	19.1	21	3.0	15	13.4	83	35	42	51	14.0	30	3	8	30	1	
<b>RKYL 62</b>	<b>RKYL 62</b>	62	27	M 24 x 1.5	22.1	22.5	3.0	19	15.4	93	37	45	54	18	35	3	10	36	1	
<b>RKYL 72</b>	<b>RKYL 72</b>	72	36	M 30 x 1.5	25.5	28	3.0	19	21.6	110	45	56	65	18	44	3	12	46	1	
<b>RKXL 90</b>	<b>RKXL 90</b>	90	38	M 36 x 1.5	32.5	32	3.5	24	24.6	128	53	56 <sup>4)</sup>	64	75	23	49	4	14	55	1
<b>RKXL 110</b>	<b>RKXL 110</b>	110	42	M 36 x 1.5	39.5	36	3.5	33	24.6	148	60	63 <sup>4)</sup>	72	83	32	59	4	14	55	1

Type		Dynamic load (N)	Limit load (N)	Torque wrench setting (Nm) <sup>2)</sup>	Weight (g)
		C <sub>w</sub> <sup>3)</sup>	radial F <sub>r</sub>		
<b>RKYL 52</b>	<b>RKYL 52</b>	40750	3050	80	630
<b>RKYL 62</b>	<b>RKYL 62</b>	46000	6850	160	950
<b>RKYL 72</b>	<b>RKYL 72</b>	64850	11200	300	1680
<b>RKXL 90</b>	<b>RKXL 90</b>	113400	13800	450	2900
<b>RKXL 110</b>	<b>RKXL 110</b>	177550	24000	450	5000

1) Housing bore tolerance: H7

2) The torque wrench settings are given for non-lubricated threads; for lubricated threads multiply figure by 0.8

3) C<sub>w</sub> = Basic load for 100 Km

4) Dimensions for stainless steel (**NX**) version

On request, the guide rollers can be supplied with external parts in stainless steel (suffix **NX**). Internal rolling elements in standard bearing steel.

Standard seals: material NBR, RS type

On request, the guide rollers can be supplied with viton seals for operating temperatures up to 120°C (suffix **V**) not available for RKXL 110)

Pressure angle  $\alpha$  for load calculation: 40°

## Spacers for FS and FSH

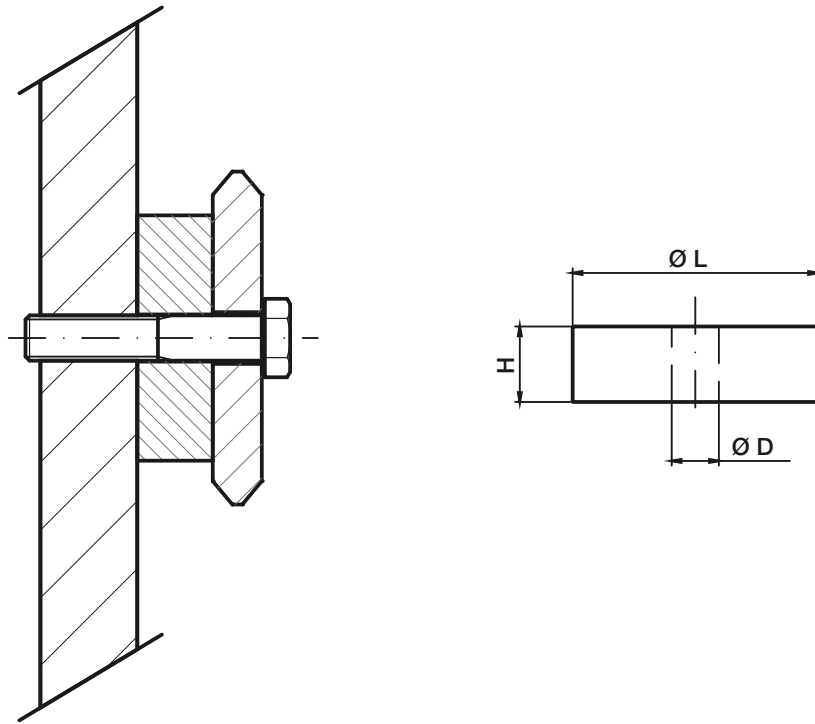

Type	Dimensions (mm)			Suggested combinations
	ØL	ØD	H	
DIST FS19	12	6.5	10	FS19, FSH19
DIST FS22	15	6.5	10	FS22, FSH22, FSR22
DIST FS32	30	6.5	15	FS32
DIST FS35	35	8.5	15	FS35, FSR35
DIST FS40	50	8.5	15	FS40
DIST FS47	60	10.5	15	FS47, FSR47
DIST FS52	65	12.5	20	FS52
DIST FS62	80	12.5	20	FS62
DIST FS72	35	16.5	20	FS72, FSH72
DIST FSH32	20	6.5	15	FSH32
DIST FSH40	25	8.5	15	FSH40
DIST FSH52	25	12.5	20	FSH52
DIST FSH62	25	12.5	20	FSH62
DIST FSX90	43	12.5	30	FSX90

The spacers, mounted between the guide and the supporting structure, guarantee adequate distance for the sliding of the rollers. The spacers DIST are designed for guides FS and FSH of V-Line and guides FSR of Multi-Motion-Line.

### Finishing

- anodized aluminium

### Optional features

- steel

# V-Line

## Lubricator LUBY for FS guide rollers up to size 40

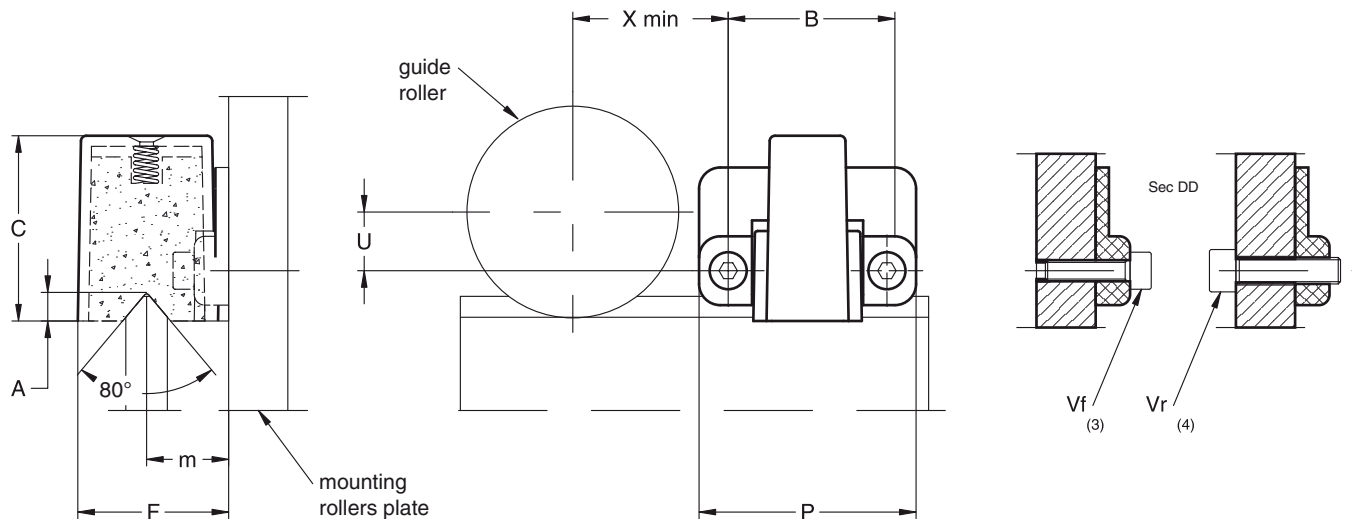
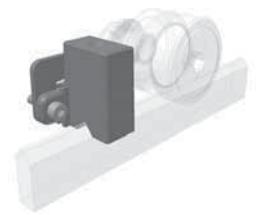

Type	Dimension (mm)										Weight (g)	Suggested combinations
	X	U	B	F	m	A	C	P	Vf	Vr		
<b>LUBY 19</b>	15	1.5	25	15.6	8.8	2.5	19	32.5	M3x12	M4	10	<b>FR... 19...</b>
<b>LUBY 22</b>	16.5	3	25	16.8	9.4	3.3	22	32.5	M3x12	M4	10	<b>FR... 22...</b>
<b>LUBY 32</b>	21.5	8	25	23.2	12.6	4.2	30	32.5	M3x12	M4	15	<b>FR... 32...</b>
<b>LUBY 40</b>	27.5	10.5	30	28.5	15.5	5.4	35	41	M4x12	M5	30	<b>FR... 40...</b>

- 1) The lubricator is supplied with the felt already lubricated. The lubricant has a mineral oil base
- 2) At the mounting, insert the screws inside the rollers plate, without tighten them, adjust the height of the plastic part in order to put it in contact with the raceways and then block it
- 3) The screws Vf for the frontal mounting are included in the packaging. Arrange two thread holes for dimension Vf in the mounting rollers plate
- 4) The screws for the mounting on the nut side of the roller are not included in the packaging. Arrange on the mounting rollers plate the holes in order to insert the screws Vr

### Optional features

- felt without lubricant (D)

# V-Line

## Lubricator LUBY, LUBX for FS guide rollers size 52 and higher

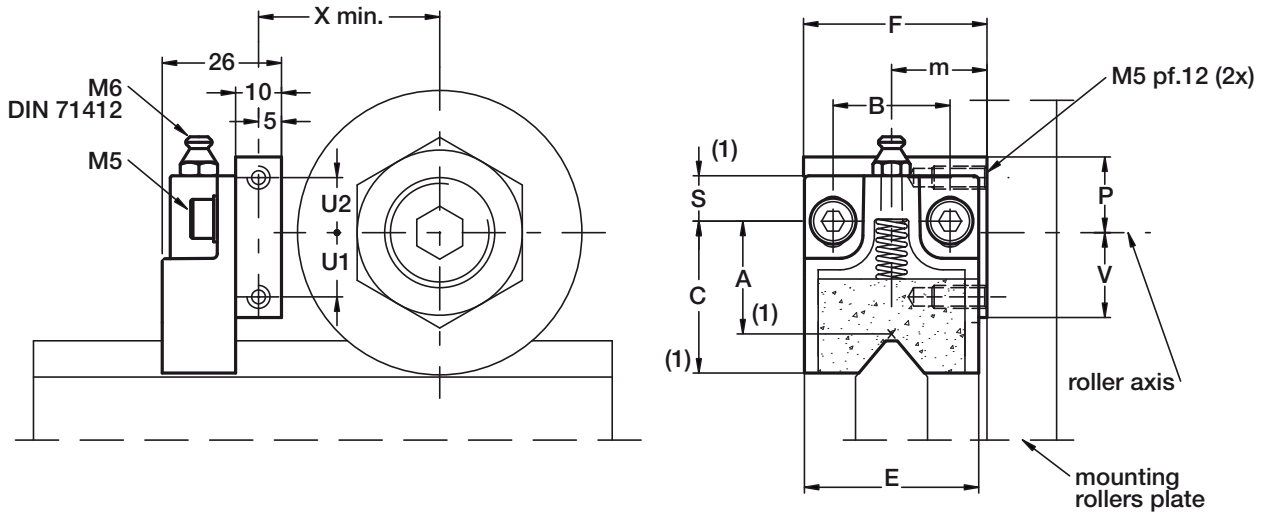

Type	Dimensions (mm)												Weight (g)	Suggested combinations
	X	U1	U2	F	m	B	S	C	A	E	V	P		
<b>LUBY 52</b>	33.5	12	14	40	19.8	25.5	10	34	24.5	38	16.5	18.5	65	<b>RKY 52 RKYR 52 FKY 52</b> <b>FR 52 EU FRR 52 EU ...AS/AZ</b>
<b>LUBY 62</b>	38.5	14	12	40	20.8	25.5	10	34	24.5	38	18.5	16.5	65	<b>RKY 62 RKYR 62 FKY 62</b> <b>FR 62 EU FRR 62 EU ...AS/AZ</b>
<b>LUBY 72</b>	43.5	19	11	50	27	25.5	10	40	29	44	24	16	85	<b>RKY 72 RKYR 72 FKY 72</b>
<b>LUBX 90</b>	52.5	21	9	60	30	30	16.5	45.5	33.5	58	31	19	140	<b>RKX 90C RKXR 90C FKX 90C</b>
<b>LUBX 110</b>	62.5	30	0	63	34	30	16.5	45.5	33.5	58	40	10	140	<b>RKX 110C RKXR 110C</b> <b>FKX 110C</b>

- 1) The dimension of the plastic part refers to the centre of the regulation slot. The regulation slot allows a translation of +/- 3 mm
- 2) The lubricator is supplied with the felt already lubricated. The lubricant has a mineral oil base
- 3) During the mounting fix the aluminium support to the rollers plate, adjust the height of the plastic part in order to put it in contact with the raceways and then block it in that position with the M5 screws

### Optional features

- felt without lubricant (D)

## Guide rollers combination

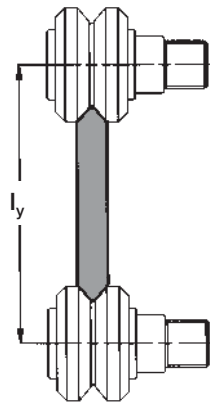

FS

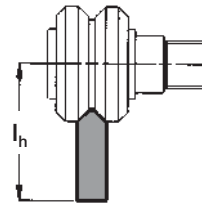

FSH / FSX

### Guide rollers FR...EU, FR...EU AS, FR...EU AZ, FRN...EI, RKY, RKX, FKY, FRL..EU, RKXL, RKYL

	ly (mm)	Guide roller size						
		19...	22...	32...	40...	52...	62...	72...
FS..M	FS 19 M	35	36.4					
	FS 22 M	41.9	43.3					
	FS 32 M			66.5				
	FS 35 M			71.5	*77			
	FS 40 M				92.8			
	FS 47 M				*107.8	116.8		
	FS 52 M					128	*134	
	FS 62 M					143	149	
	FS 72 M						*167.2	174

	lh (mm)	Guide roller size									
		19...	22...	32...	40...	52...	62...	72...	90...	110...	
FSH..M, FSX..M	FSH 19 M	26	26.7								
	FSH 22 M	*29.9	30.6								
	FSH 32 M			40.7							
	FSH 40 M			*48	50.9						
	FSH 52 M				*54	58.5					
	FSH 62 M					*68.5	71.5				
	FSH 72 M						*81.6	85			
	FSX 90 M								94.3	101.3	

	ly (mm)	Guide roller size						
		19...	22...	32...	40...	52...	62...	72...
FS..MT	FS 19 MT	36.2	37.6					
	FS 22 MT		44.2					
	FS 32 MT			67.4				
	FS 35 MT			72.4	*78			
	FS 40 MT				93.7			
	FS 47 MT				*109.3	118.3		
	FS 52 MT					129.5	*135.5	
	FS 62 MT					144.2	150.2	
	FS 72 MT						*168.8	175.6

	lh (mm)	Guide roller size									
		19...	22...	32...	40...	52...	62...	72...	90...	110...	
FSH..MT, FSX..MT	FSH 22 MT	30.9	31.6								
	FSH 32 MT			41.7							
	FSH 40 MT			*49	51.8						
	FSH 52 MT				*55.4	59.9					
	FSH 62 MT					*69.9	72.9				
	FSH 72 MT						*83	86.4			
	FSX 90 MT								95.3	102.3	

\* possible combination

## Mounting examples

Waterjet cutting machine  
V-Line

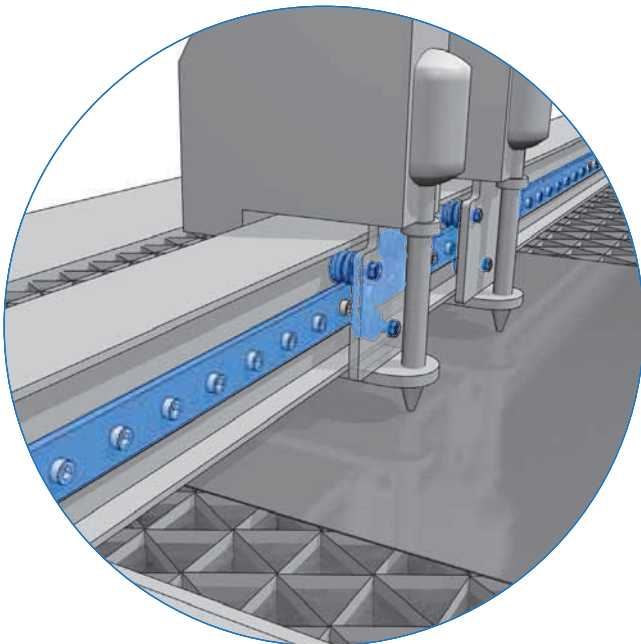
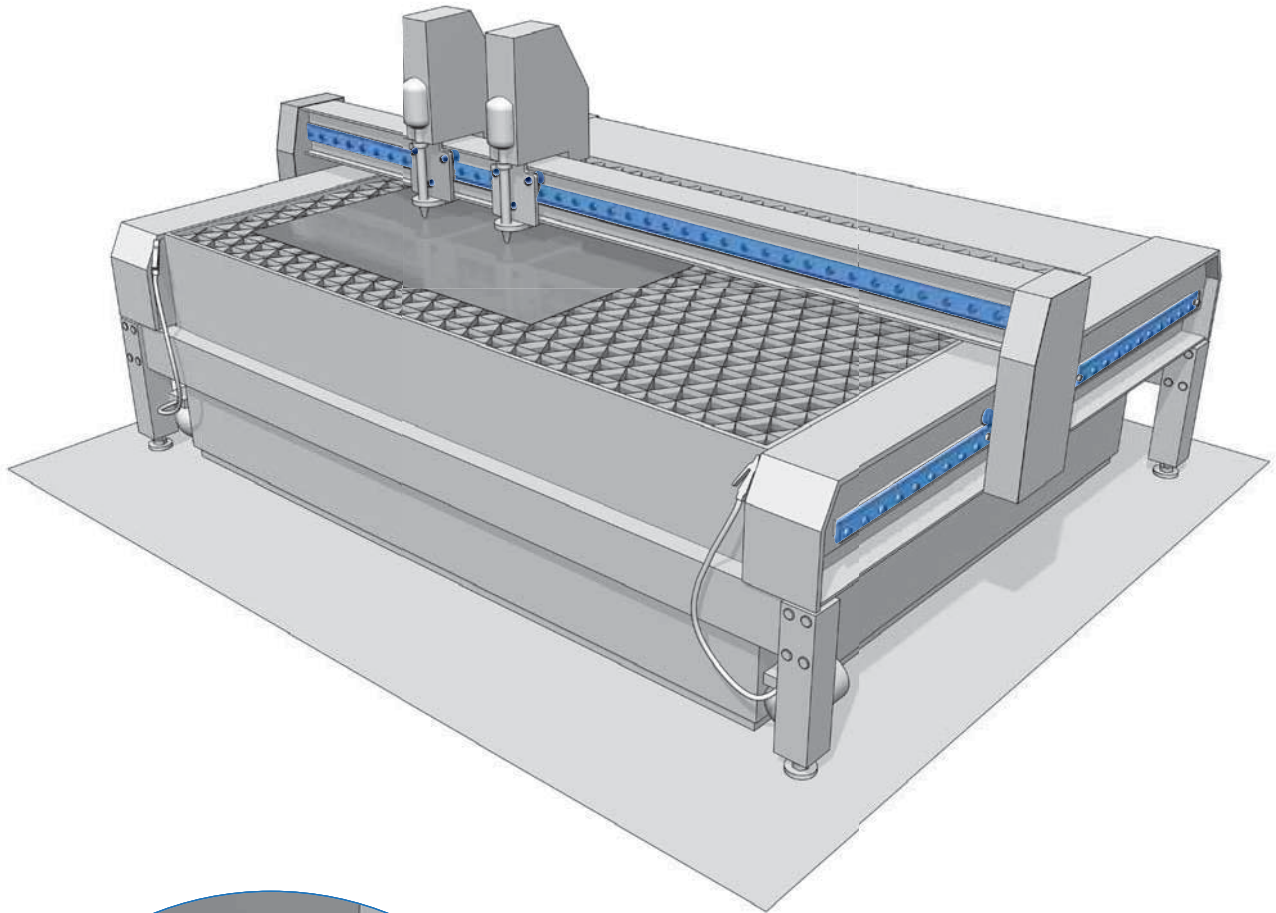

## Mounting examples

Portable loader for steel sheet  
V-Line  
Heavy-Line

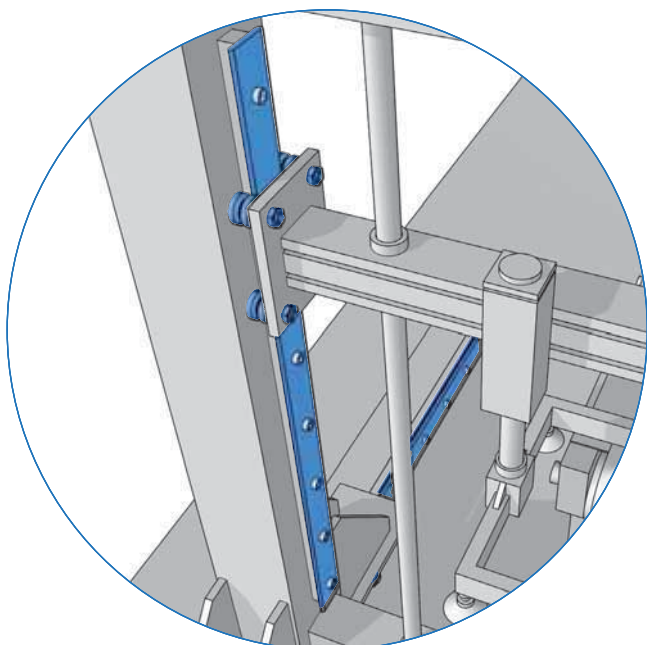
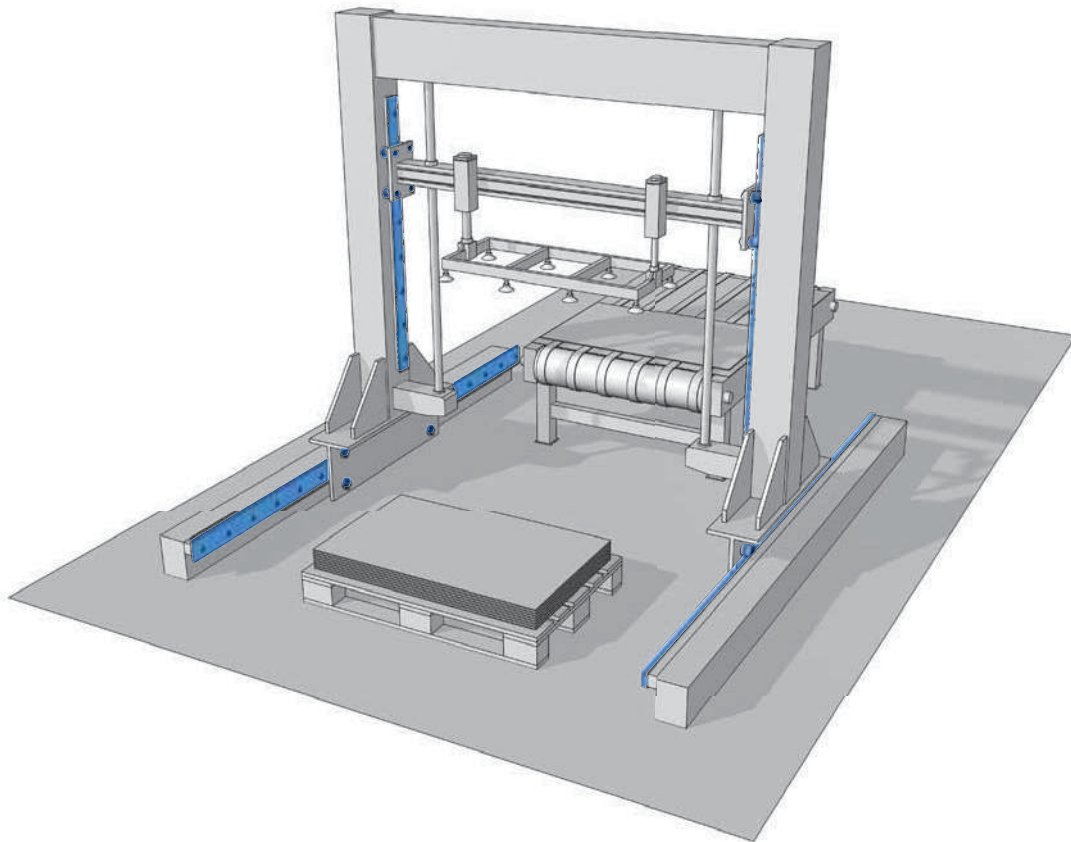

# Multi-Motion-Line

## FSR System

---

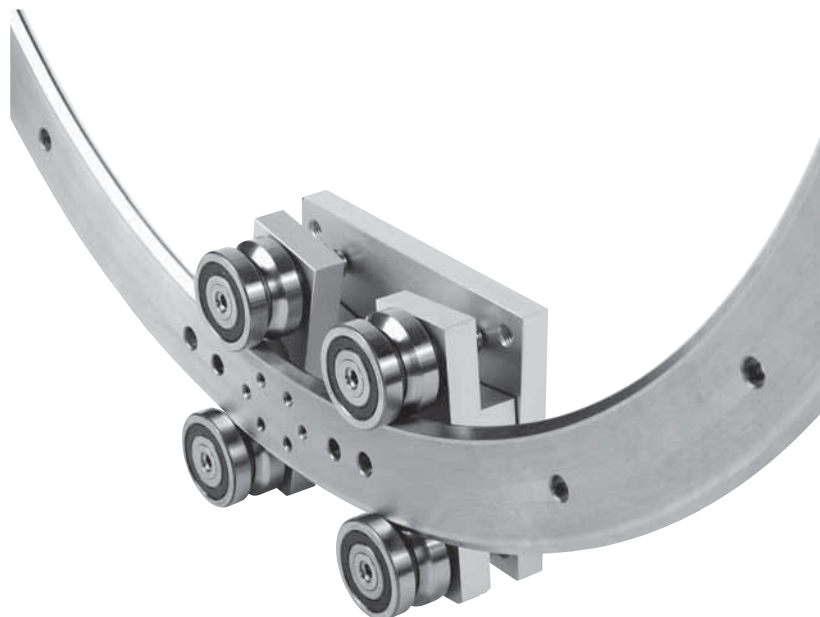

# Multi-Motion-Line

## Circular systems

Nadella proposes several circular rails based on the FS family of profiles. The rails can be used as an entire circumference, or single sectors, or joined together with straight pieces of rail in order to obtain oval or ring circuits.

### Guide

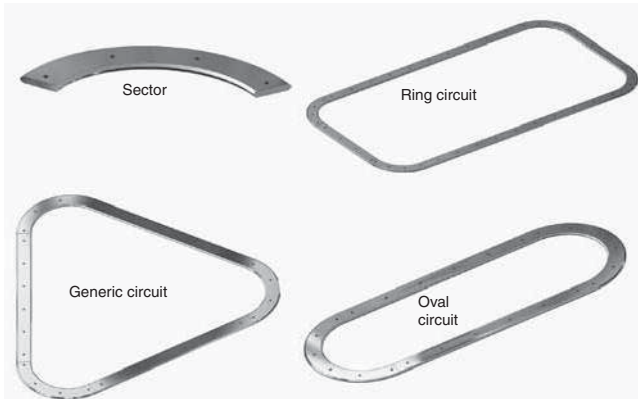

The rails are steel, induction hardened on the raceways, with the same section dimensions as straight FS..M rails. In the circuits the rails are joined together with alignment blocks that allow easy precise mounting.

All the pieces of the circuit are supplied appropriately marked in order to avoid mistakes during joining.

For protection against corrosion Nadella proposes nickel plating (option NW) for both straight and circular pieces.

In addition to the standard dimensions in the table it is possible to realize rings with different sections or radii in order to satisfy specific demands.

### Guide rollers

Any guide rollers of the FS family of products can be used in combination with the circular rails.

### Carriage

Carriages for circular rails can be realized with guide rollers in fixed position or mounted on steering arms.

### Carriages with guide rollers in fixed positions

You can set up the distance between the centres of the guide rollers of a carriage with fixed guide rollers in order to obtain clearance-free running both on the straight and on the circular stretch of a circuit. The resulting carriage, normally a simple table with four holes for the housing of the guide rollers, will be simple and compact; there are, however, some contraindications:

- In the passage from the straight stretch to the circular one (and vice versa), when two guide rollers are engaged on the straight portion and two on the circular one, there will be clearance between the carriage and

the rail. The extent of the clearance depends on the dimensions of the rail, of the roller guides and of the carriage. Because of this clearance it is not possible to have an accurate positioning of the carriage during the passage between straight and circular stretch and therefore, in fast application, there will be vibration, noise and overload of the roller guides.

- This kind of carriages, with fixed guide rollers, can be used only for a single specific radius throughout the circuit. To use a carriage with fixed guide roller positions you can't have circular stretches with different radii.

To define the design for holes of the fixed rollers please contact the Nadella Technical Service.



### Steering Carriages

The contraindications for the carriage with guide rollers in fixed positions can be resolved by using the steering carriage. Guide rollers are mounted in pairs on steering arms that are free to rotate in order to always be transversal to the rail in every point of the circuit. The carriage won't have clearance at any point in the circuit improving transition area accuracy and reduce running noise.

The studs of the steering carriage are fitted with needle bearings and seals for lubricant retention and protection. The tightening of the stud is obtained by the full tightening of the nut, and guarantees the best locking.

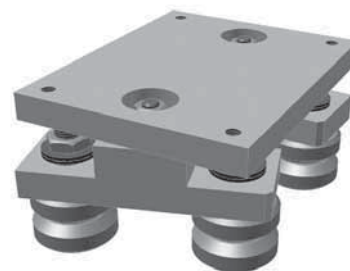

# Multi-Motion-Line

## Circular rails FSR..M

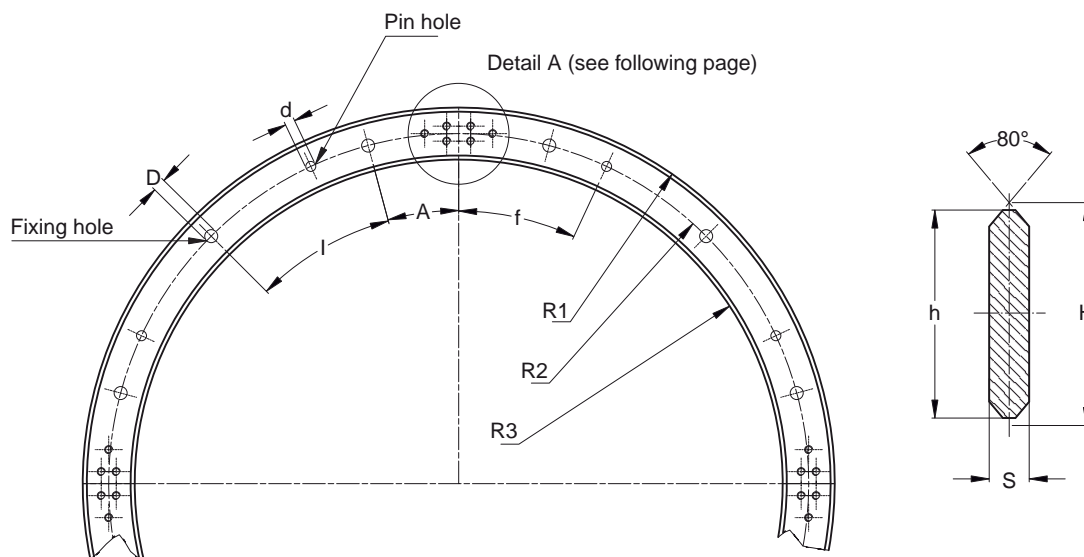

Type	A	l	f	d H7	D	R1*	R2*	R3*	n° fixing holes/360°	n° pin holes/360°	h	H	S
<b>FSR22M-075</b>	22.5°	45°	45	5	6.5	88	75	62	8	4	26	27.86	5
<b>FSR22M-125</b>	15°	30°	25°	5	6.5	138	125	112	12	8	26	27.86	5
<b>FSR22M-175</b>	15°	30°	25°	5	6.5	188	175	162	12	8	26	27.86	5
<b>FSR35M-225</b>	11.25°	22.5°	7.5°	8	9	248	225	202	16	8	46	47.86	8
<b>FSR35M-300</b>	11.25°	22.5°	7.5°	8	9	323	300	277	16	8	46	47.86	8
<b>FSR47M-400</b>	9°	18°	18°	10	11.5	438	400	362	20	8	76	78.58	10
<b>FSR47M-500</b>	9°	18°	18°	10	11.5	538	500	462	20	8	76	78.58	10

\* R1, R2, R3 are radius

### Rails finishing

- steel
- induction hardened on the raceways

### Hole layout

- holes according to catalogue (**SB**)
- finishes to drawing (**NZ**)

### Optional features

- stainless steel (**NX**)
- nickel plating (**NW**)
- spacers for rails **FS** (page 58)

Example of standard designation: **FSR35M-225-180**

Circular rail sector FSR35M, radius R2 225 mm, sector angle 180°

# Multi-Motion-Line

## Alignment blocks for FSR

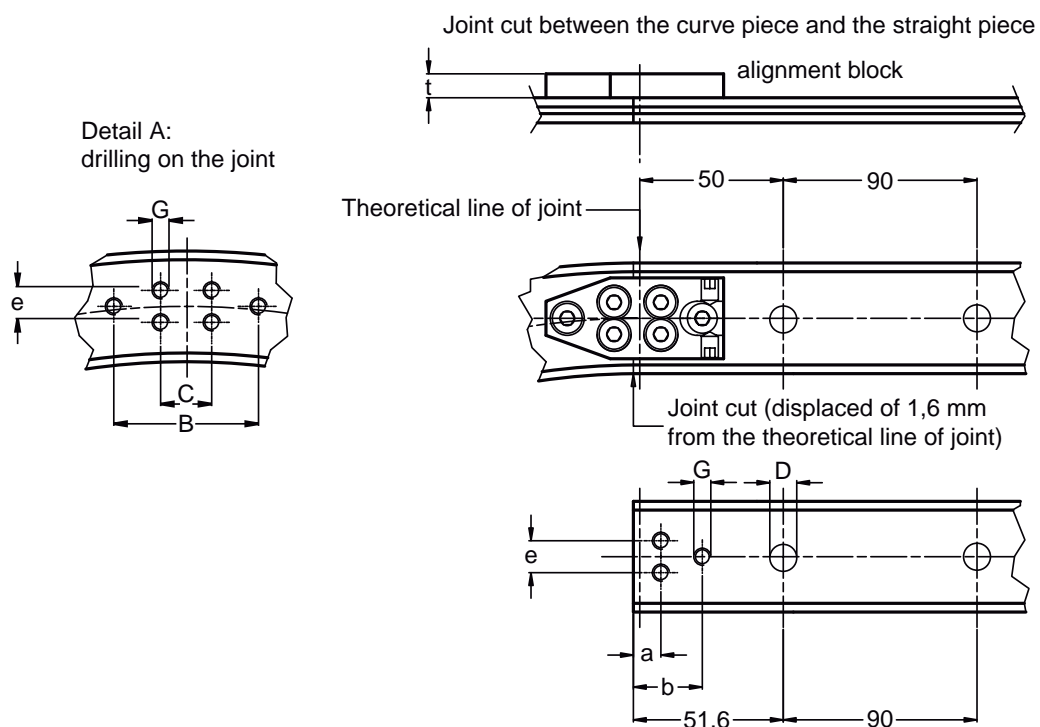

Type	Dimensions (mm)								Suggested combination
	C	B	e	G	D	a	b	t	
FSR22M-075	12	34	7.5	M4	6.5	7.6	18.6	5.8	FR22EU FRN22EI
FSR22M-125	12	34	7.5	M4	6.5	7.6	18.6	5.8	FR22EU FRN22EI
FSR22M-175	12	34	7.5	M4	6.5	7.6	18.6	5.8	FR22EU FRN22EI
FSR35M-225	18	38	20	M6	9	10.6	19.6	6	FR32EU FRN32EI FR40EU FRN40EI
FSR35M-300	18	38	20	M6	9	10.6	19.6	6	FR32EU FRN32EI FR40EU FRN40EI
FSR47M-400	18	58	43	M6	11.5	8.6	18.1	9	FR40EU FRN40EI FR52EU RKY52
FSR47M-500	18	58	43	M6	11.5	8.6	18.1	9	FR40EU FRN40EI FR52EU RKY52

The joint cut is displaced of 1.6 mm from the theoretical line of joint.  
The alignment block allows an easy mounting of the joint.

## Spacers for FSR

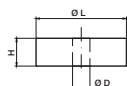
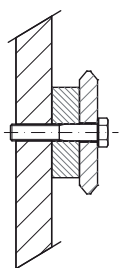

Spacers **DIST FS** can be used to mount the rails FSR (pag. 60)

# Multi-Motion-Line

## Oval circuit FSRO

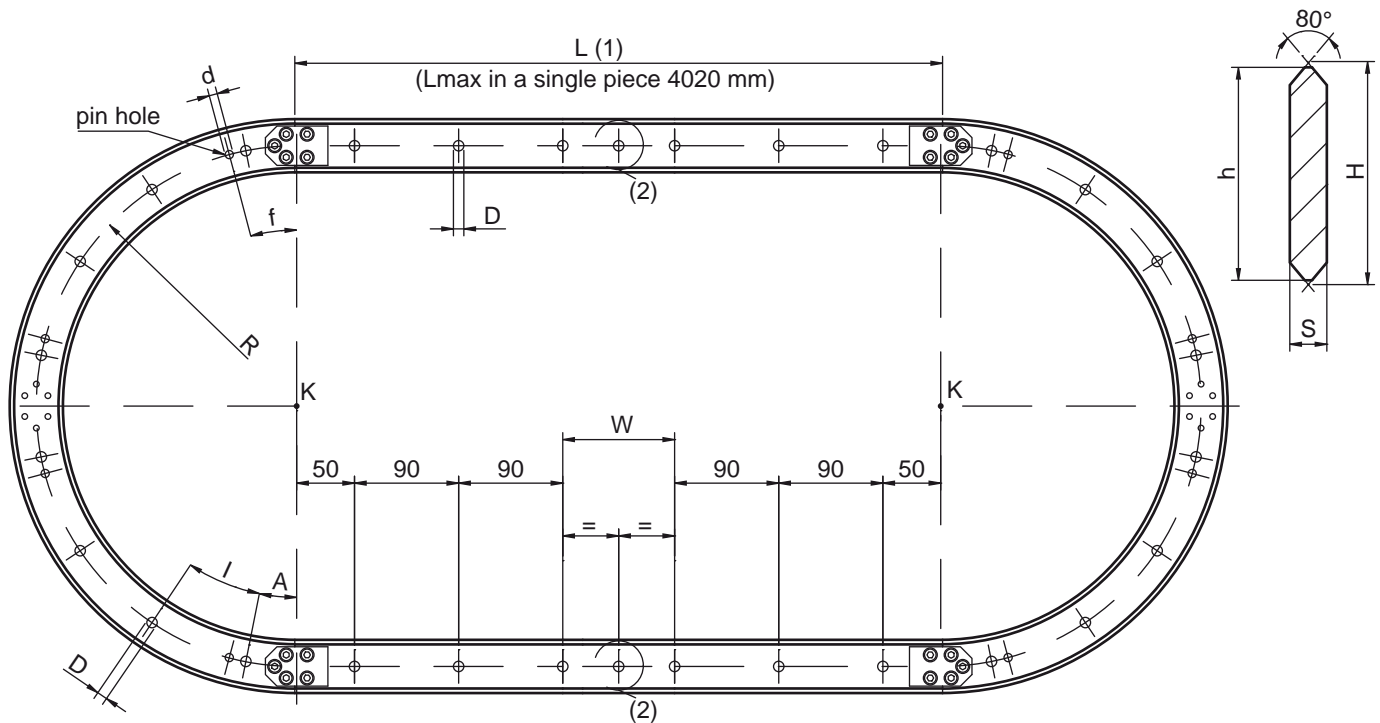

Type	Dimensions (mm)								
	Radius R	D	A	l	d H7	f	S	h	H
FSRO22M-075-...	75	6.5	22.5°	45°	5	45°	5	26	27.86
FSRO22M-125-...	125	6.5	15°	30°	5	25°	5	26	27.86
FSRO22M-175-...	175	6.5	15°	30°	5	25°	5	26	27.86
FSRO35M-225-...	225	9	11.25°	22.5°	8	7.5°	8	46	47.86
FSRO35M-300-...	300	9	11.25°	22.5°	8	7.5°	8	46	47.86
FSRO47M-400-...	400	11.5	9°	18°	10	18°	10	76	78.58
FSRO47M-500-...	500	11.5	9°	18°	10	18°	10	76	78.58

The oval circuit is composed by: two sectors of circular rails (180° with center in K) and two straight pieces of rails. The circuit is supplied complete of alignment blocks (with the proper screws), and all the pieces are marked in order to obtain the correct sequence during the mounting.

(1) The length of the straight pieces is higher than the distance between the centers K (1.6 mm x 2) in order to cover the thickness of rail lost during the cutting of the circular sectors (for more details about joints see page 68).

### Standard hole layout (SB) for the straight rails:

- first and last hole of 50 mm, starting from the centers K;
- hole pitch 90 mm;
- central hole (2) only if the last hole pitch W is higher than 120 mm;
- W can't be less than 60 mm.

### Rails finishing

- for the circular rail see page 67
- for the straight rail see page 49

### Hole layout

- standard holes according to catalogue (SB)
- finishes to drawing (NZ)

### Optional features

- stainless steel (NX)
- nickel plating (NW)

Example of standard designation: **FSRO35M-225-2000 SB**  
Oval circuit, size 35, radius 225 mm, distance between the centers K equal to 2000 mm (1), standard holes.

# Multi-Motion-Line

## Ring circuit FSRQ

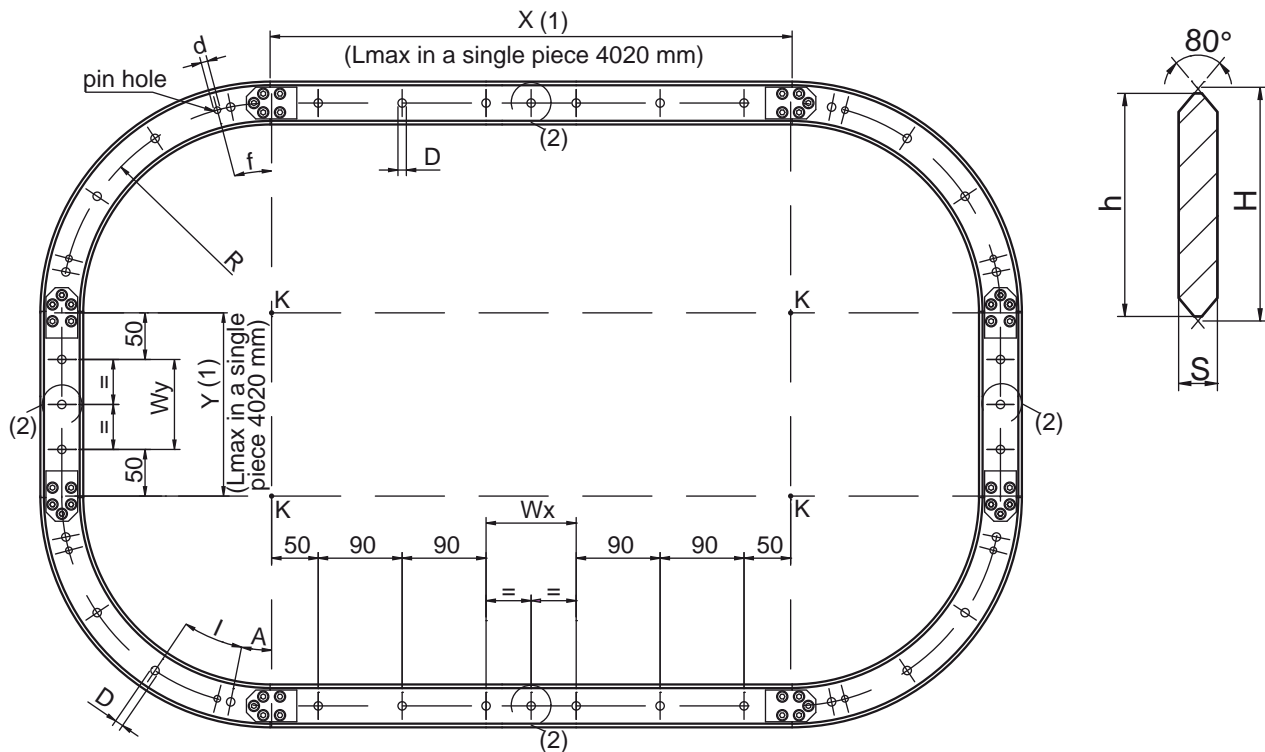

Type	Dimensions (mm)								
	Radius R	D	A	I	d H7	f	S	h	H
FSRQ22M-075-...	75	6.5	22.5°	45°	5	45°	5	26	27.86
FSRQ22M-125-...	125	6.5	15°	30°	5	25°	5	26	27.86
FSRQ22M-175-...	175	6.5	15°	30°	5	25°	5	26	27.86
FSRQ35M-225-...	225	9	11.25°	22.5°	8	7.5°	8	46	47.86
FSRQ35M-300-...	300	9	11.25°	22.5°	8	7.5°	8	46	47.86
FSRQ47M-400-...	400	11.5	9° 55'	18°	10	18°	10	76	78.58
FSRQ47M-500-...	500	11.5	9°	18°	10	18°	10	76	78.58

The ring circuit is composed by: four sectors of circular rails (90° with center in K) and four straight pieces of rails. The circuit is supplied complete of alignment blocks (with the proper screws), and all the pieces are marked in order to obtain the correct sequence during the mounting.

(1) The length of the straight pieces is higher than the distance between the centers K (1,6 mm x 2) in order to cover the thickness of rail lost during the cutting of the circular sectors (for more details about joints see page 68).

### Standard hole layout (SB) for the straight rails:

- first and last hole at 50 mm, starting from the centers K;
- hole pitch 90 mm;
- central hole (2) only if the last hole pitch (Wx in horizontal and Wy in vertical) is higher than 120 mm;
- Wx and Wy can't be less than 60 mm.

### Rails finishing

- for the circular rail see page 67
- for the straight rail see page 49

### Hole layout

- standard holes according to catalogue (SB)
- finishes to drawing (NZ)

### Optional features

- stainless steel (NX)
- nickel plating (NW)

Example of standard designation: **FSRQ35M-225-2000-1000 SB**  
 Ring circuit, size 35, radius 225 mm, horizontal distance between the centers K equal to 2000 mm (1), vertical distance between the centers K equal to 1000 mm (1), standard holes.

# Multi-Motion-Line

## Steering carriage T4R...

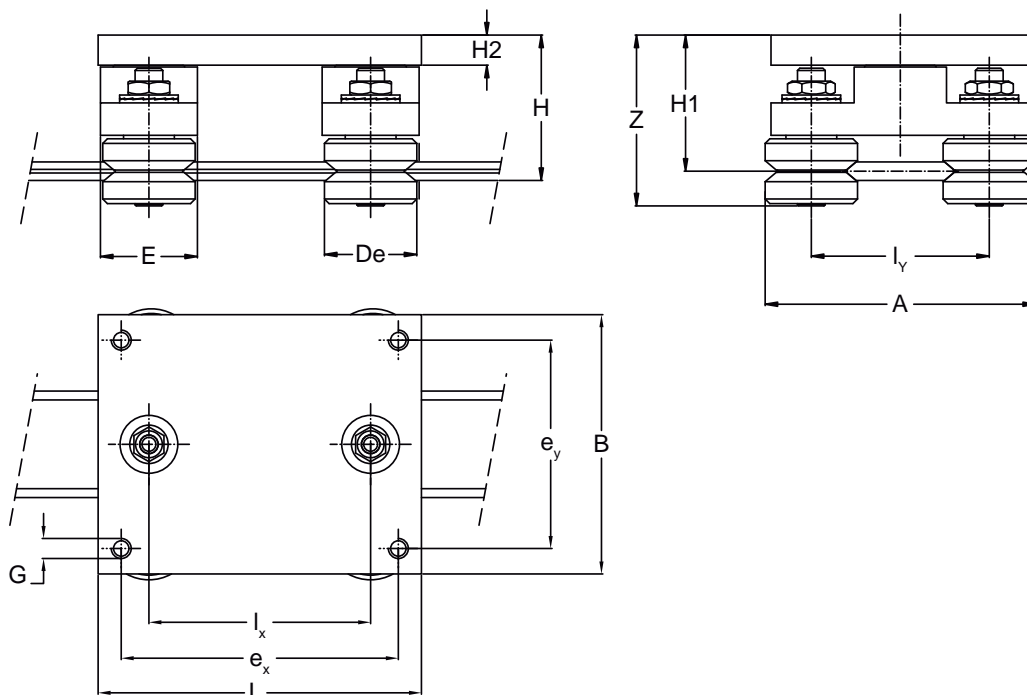

Type	Dimensions (mm)														Weight (kg)	Suggested combination
	De	L	B	e <sub>x</sub>	e <sub>y</sub>	I <sub>x</sub>	I <sub>y</sub>	H	H1	H2	G	A	E	Z		
T4R22 FR22EU 80 T4R22 FRN22EI 80	22	80	62	68	50	50	43.3	45.5	43	12	M5	65.3	27	51.6 53.6	0.5	FSR 22 M FS 22 M
T4R35 FR32EU 140 T4R35 FRN32EI 140	32	140	112	120	90	96	71.5	59.9	55.9	13	M8	103.5	42	66.2 69.3	1.1	FSR 35 M FS 35 M
T4R35 FR40EU 140 T4R35 FRN40EI 140	40	140	112	120	90	96	77	62.8	58.8	13	M8	117	42	72.8 74.3	1.6	FSR 35 M FS 35 M
T4R47 FR40EU 180 T4R47 FRN40EI 180	40	180	160	150	130	120	107.8	74.3	69.3	19	M10	147.8	56	83.3 84.8	2.4	FSR 47 M FS 47 M
T4R47 FR52EU 180 T4R47 RKY52 180	52	180	160	150	130	120	116.8	78.6	73.6	19	M10	168.8	56	90.3 94.8	3.3	FSR 47 M FS 47 M

# Multi-Motion-Line

## Mounting example

Assembly line  
Multi-Motion-Line

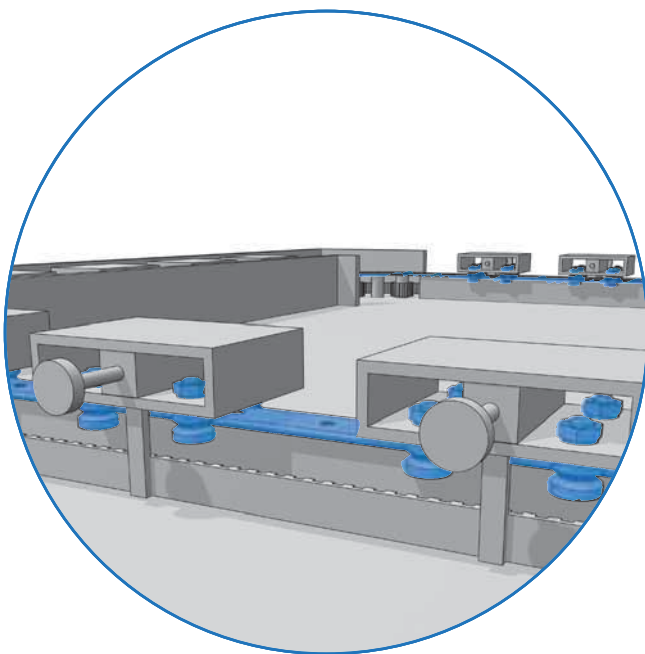
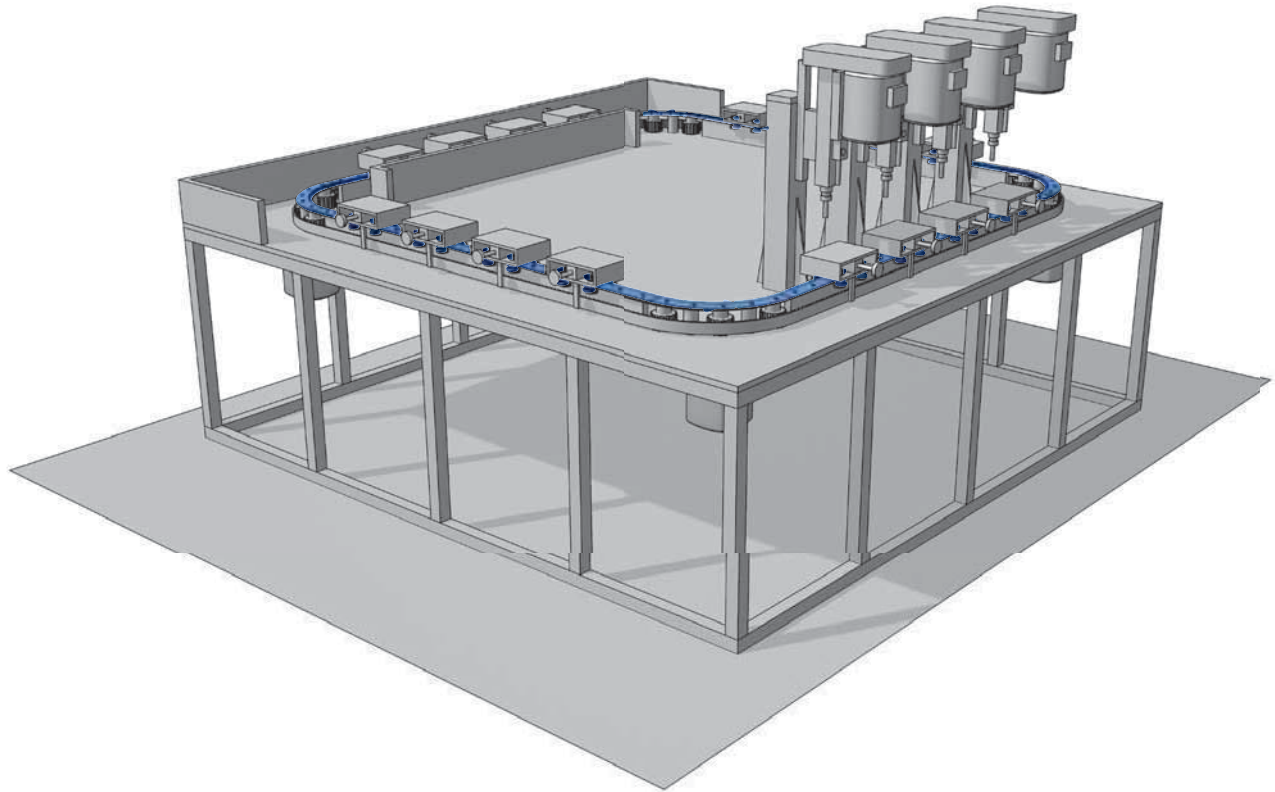

# C-Line

## System LS

---



## System LS

To be in a position to offer complete guide systems the C-Line consists of guide rails, guide rollers and carriages. Guide rails and rollers can be used as individual components; in most cases however, standard carriages are used.

The cold drawn rails have a C shape and are induction hardened. The rollers run on the inside raceways of the C-profile. The rails are zinc-plated; alternatively they are available with nickel-plated surface.

Based on the different design of the rollers, constructions with fixed or floating bearings can be realised. Thereby errors in parallelism, height and angle can be balanced. Only one rail shape is necessary for this.

Nadella offers 3 rail sizes.

The carriages can be adjusted free of play. They are equipped with concentric and eccentric rollers and can be combined with 3, 4 or 5 rollers.

### Essential technical properties:

- steel rail, drawn, induction hardened
- zinc-plated rail, alternatively with nickel-plated surface
- rollers for fixed and floating bearing constructions
- high balance of mounting surface errors and misalignment
- high performance and rugged
- rollers lubricated for life
- dust resistant
- easy fitting
- easy smooth running
- high speeds up to 8 m/s (depending on roller size and application)
- acceleration up to 50 m/s<sup>2</sup>
- working temperatures up to 80°C possible
- pitch of rail borings standard or according to customer drawings
- integrated lubricating system at the front sides of the carriage

The following figure applies to the loads indicated in the tables below:

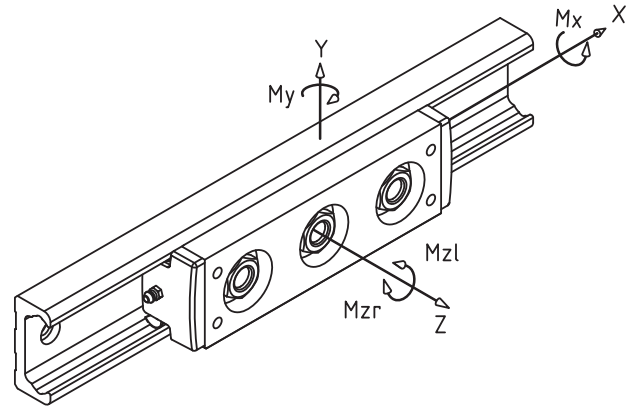

### MAX LOAD ON INDIVIDUAL CARRIAGES

The tables below show the maximum load that can be applied to an individual carriage.

#### Short carriage

Guide	Carriage	Fy N	Fz N	Mx Nm	My Nm	Mz Nm	
						Mzl	Mzr
LS 28	C3 RCS28 126	2400	660	5.9	17	30	30
LS 43	C3 RCS43 170	6000	1700	23	66	117	117
LS 63	C3 RCS63 226	13000	4400	81	264	390	390

Fy with effect on the concentric rollers.

#### Long carriage

Guide	Carriage	Fy N	Fz N	Mx Nm	My Nm	Mz Nm	
						Mzl	Mzr
LS 28	C3 RCS28 178 A	2400	660	5.9	34	62	62
	C4 RCS28 178 C	2400	1320	12	43	94	94
	C4 RCS28 178 A	1800	990	8.9	38	125	62
	C4 RCS28 178 B	1800	990	8.9	38	62	125
	C5 RCS28 178 A	3000	1320	12	43	94	94
	C5 RCS28 178 B	3600	660	5.9	35	62	62
LS 43	C3 RCS43 245 A	6000	1700	23	129	228	228
	C4 RCS43 245 C	6000	3400	45	162	342	342
	C4 RCS43 245 A	4500	2380	34	129	456	228
	C4 RCS43 245 B	4500	2380	34	129	228	456
	C5 RCS43 245 A	7500	3400	45	162	342	342
	C5 RCS43 245 B	9000	1700	23	133	228	228

Fy with effect on the concentric rollers.

The max load is based on the guide roller values (load capacity of bolt and bearing) and on the max contact pressure of 1250N/mm<sup>2</sup> between rail and roller. Loads are rated for effect in direction Y exclusively or in direction Z exclusively. A combination of rates reduces the values.

## System LS

### DYNAMIC LOAD CAPACITY OF THE INDIVIDUAL CARRIAGE

The following tables indicate the nominal load which corresponds to a nominal bearing lifetime of 100 km.

$$L_{10} = (C_i/P_i)^3 \times 100 \text{ km}$$

$C_i$  and  $P_i$  are the load capacity and the applied load for a certain load direction.

#### Short carriage

Guide	Carriage	C <sub>y</sub> N	C <sub>z</sub> N	C <sub>Mx</sub> Nm	C <sub>My</sub> Nm	C <sub>Mz</sub> Nm	
						M <sub>z1</sub>	M <sub>zr</sub>
LS 28	C3 RCS28 126	4400	1100	9.6	27	55	55
LS 43	C3 RCS43 170	13200	3600	48	142	257	257
LS 63	C3 RCS63 226	28400	6700	124	403	852	852

$C_y$  with effect on the concentric rollers.

#### Long carriage

Guide	Carriage	C <sub>y</sub> N	C <sub>z</sub> N	C <sub>Mx</sub> Nm	C <sub>My</sub> Nm	C <sub>Mz</sub> Nm	
						M <sub>z1</sub>	M <sub>zr</sub>
LS 28	C3 RCS28 178 A	4400	1100	9.6	55	114	114
	C4 RCS28 178 C	4400	2100	19	69	172	172
	C4 RCS28 178 A	3300	1600	14	61	229	114
	C4 RCS28 178 B	3300	1600	14	61	114	229
	C5 RCS28 178 A	6600	2100	19	69	172	172
	C5 RCS28 178 B	8800	1100	9.6	67	114	114
LS 43	C3 RCS43 245 A	13200	3600	48	277	502	502
	C4 RCS43 245 C	13200	7300	96	346	752	752
	C4 RCS43 245 A	9900	5100	72	304	1003	502
	C4 RCS43 245 B	9900	5100	72	304	502	1003
	C5 RCS43 245 A	19800	7300	96	346	752	752
	C5 RCS43 245 B	26400	3600	48	292	502	502

$C_y$  with effect on the concentric rollers.

### CARRIAGE CONFIGURATIONS

In the following carriage configurations the dashed guide rollers (⇐) are concentric and fixed, the plain guide roller (^) are eccentric and can be set to preload the system.

#### Short carriage with 3 rollers

Type C3... view from above

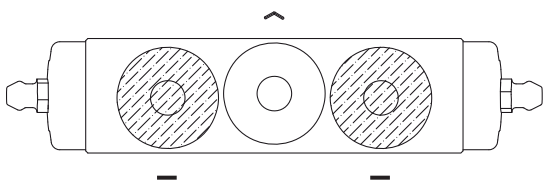

#### Long carriage with 3 rollers

Type C3...A view from above

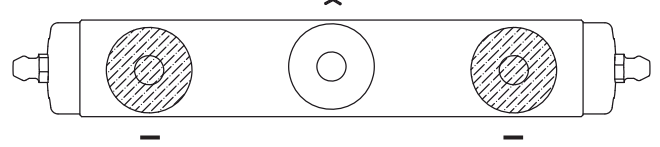

#### Long carriage with 4 rollers

Type C4...C view from above

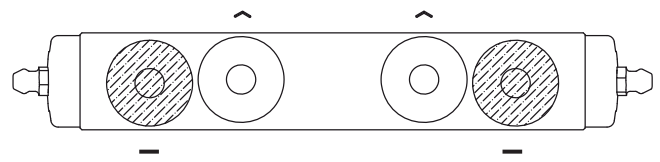

Type C4...A view from above

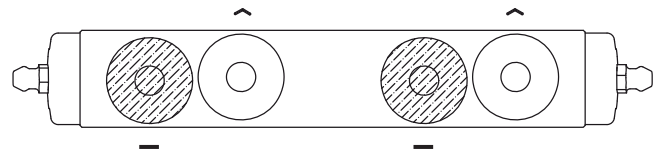

Type C4...B view from above

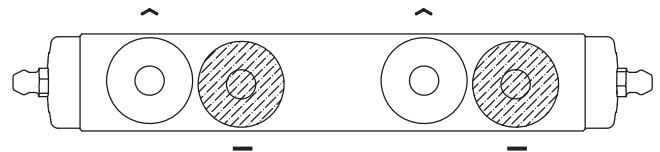

#### Long carriage with 5 rollers

Type C5...A view from above

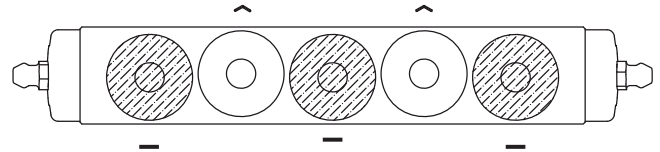

Type C5...B view from above

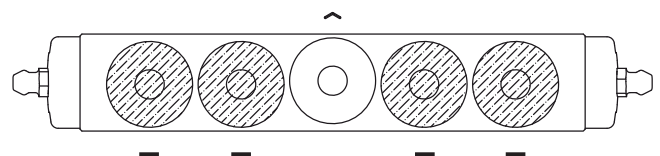

The markings ^ and - show the contact points with the running surface of the rails.

## System LS

### Calculation example: platform with 4 carriages C3 RCS 43 170 N

The general arrangement is shown in the drawing below.

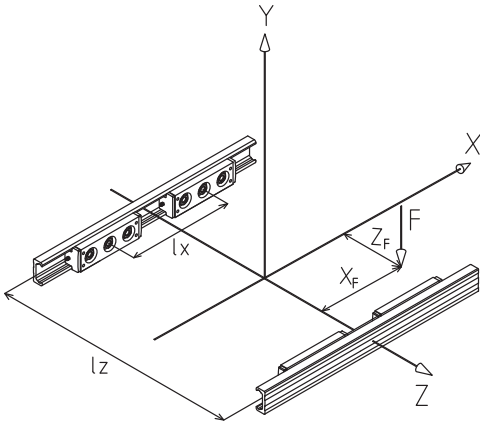

The platform runs along the two rails and is charged with load  $F$  which takes effect 100 mm and 50 mm afar from the middle of the carriage.

Data: guide LS 43; carriage C3 RCS 43 170

$$l_x = 400 \text{ mm}, \quad l_z = 300 \text{ mm}$$

$$F = 6000 \text{ N}, \quad X_F = 100 \text{ mm}, \quad Z_F = 50 \text{ mm}$$

In this configuration  $P_y$  is the load on the mostly loaded carriage and is calculated as follows:

$$P = \frac{F}{4} + \frac{F \cdot X_F}{2 \cdot l_x} + \frac{F \cdot Z_F}{2 \cdot l_z} = 2750 \text{ N}$$

The load  $F_y$  indicated in the table of max load for carriage C3 RCS 43 170 is 6000 N.

The system nominal lifetime is calculated as follows: from the table of the dynamic load capacity, the value  $C_y$  for carriage C3 RCS 43 170 is 13200 N.

$$L_{10} = (13.200/2.750)^3 \times 100 = 11.059 \text{ km}$$

Important remark: The rail must be lubricated to reach this value. Otherwise the expected lifetime can be reduced by fretting between rail and roller.

### Auto-aligning systems

Self-aligning systems are used to balance high mounting surface tolerances between two parallel installed guides. The Nadella system LS can be combined with the rollers RCS and RAS so that high horizontal or vertical tolerances can be balanced.

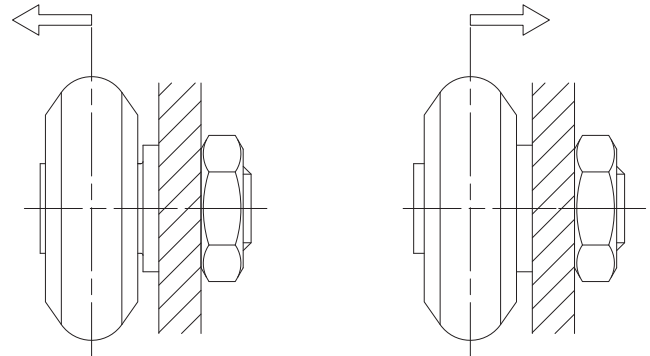

### Horizontal adjustment $D_x$

#### Fixed bearing:

Carriages equipped with rollers type RCS/RCSR to compensate radial and axial loads.

#### Floating bearing:

Carriages equipped with rollers type RAS/RASR to compensate radial loads only.

Max. possible value:  $D_x = 1,5 \text{ mm}$

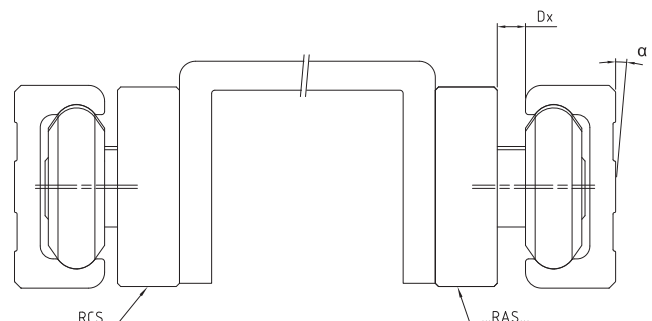

## System LS

### Vertical adjustment $D_y$

#### Fixed bearing:

Carriages equipped with concentric rollers type RCS and eccentric rollers type RASR to compensate radial and axial loads. This allows for a tilting movement of the carriage up to the max. tilting angle.

#### Floating bearing:

Carriages equipped with concentric rollers type RAS and eccentric rollers type RASR to compensate axial loads only.

The value  $D_y$  depends on the distance between the rails and the max. possible tilting angle  $\alpha = \pm 1.5^\circ$  of the carriage at the fixed bearing side.

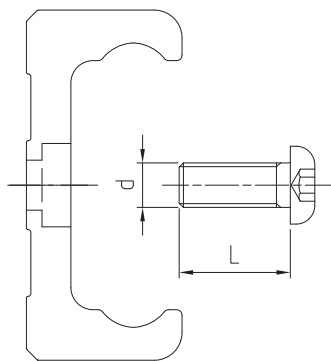
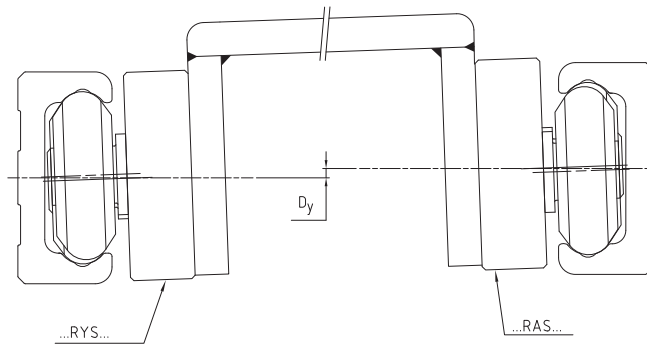

Screw type DIN EN ISO 7380 (10.9)

### Max inclined movement admissible for self-aligning tables and carriages

Carriage	$\alpha$ ax (°)	S (mm)	H nominal (mm)	Guide
C3 RAS28... C4 RAS28... C5 RAS28...	1°	-0.5/+1.2	24	LS 28
C3 RAS43... C4 RAS43... C5 RAS43...	1.5°	-0.8/+1.5	37	LS 43
C3 RAS63...	1°	-1/+3	50.5	LS 63
C3 RYS28... C4 RYS28... C5 RYS28...	1°	---	24	LS 28
C3 RYS43... C4 RYS43... C5 RYS43...	1.5°	---	37	LS 43
C3 RYS63...	1°	---	50.5	LS 63

Carriages type ...RAS... only consist of guide rollers type RAS (concentric) and RASR (eccentric).

Carriages type ...RYS... only consist of guide rollers type RCS (concentric) und RASR (eccentric).

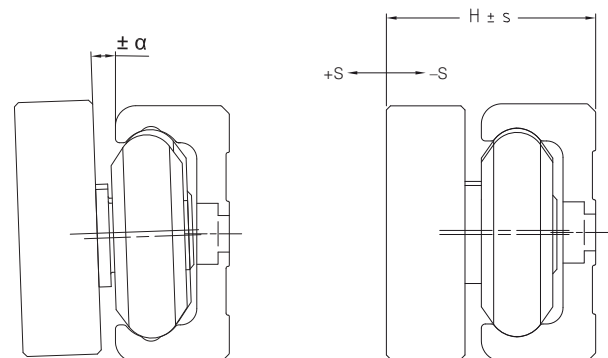

Guide	Screw size d	L	Torque wrench settings (Nm)
LS 28	M5 x 0.8	12	8
LS 43	M8 x 1.25	16	22
LS 63	M8 x 1.25	20	34



### Hole pattern A: boring for counterbore screws according DIN EN ISO 7380

LS 28

LS 43

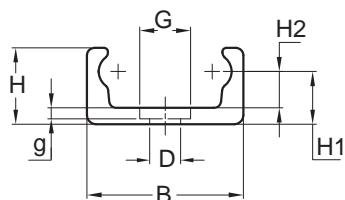

LS 63

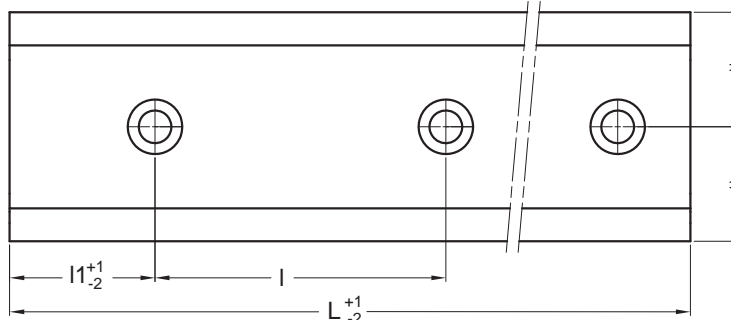
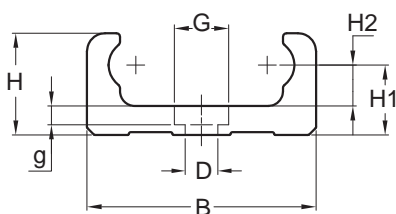

### Hole pattern B: boring for countersunk screws according DIN EN ISO 74

LS 28

LS 43

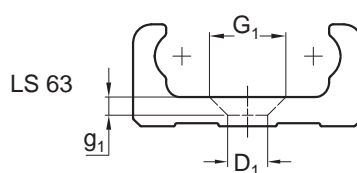
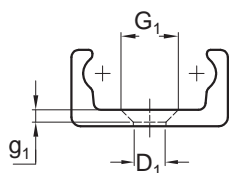

Type	Dimensions (mm)												Moment of inertia (cm <sup>4</sup> )		Weight (kg/m)	L <sup>(1)</sup> max (mm)
	B	H	H <sub>1</sub>	H <sub>2</sub>	D	G	g	D <sub>1</sub>	G <sub>1</sub>	g <sub>1</sub>	l	l <sub>1</sub>	J <sub>x</sub>	J <sub>y</sub>		
LS 28	28	12.5	9	5.5	6.6	11	2.1	5.5	10.6	2.6	80	40	0.17	1.45	1.18	2960
LS 43	43	21	14.5	10	9	15	2.5	9	17	4	80	40	1.28	8.6	2.75	2960
LS 63	63	28	19.25	11.25	9	15	4.5	11	21	5.5	80	40	4.5	38.9	6.22	2960

1) Longer rails will be fitted with finish-machined joints.

#### Rail design standard

- drawn, induction hardened raceways (MT)
- surface zinc-plated (GZ)

#### Surface options

- chemically nickel-plated (NW)
- uncoated blasted (no suffix)

#### Fixing holes

- hole pattern according to catalogue (A or B)
- hole pattern according to drawing (NZ)
- without holes (NF)

Example standard type: **LS43MT2480AGZ**

Screws DIN EN ISO 7380 (10.9) are included in delivery.

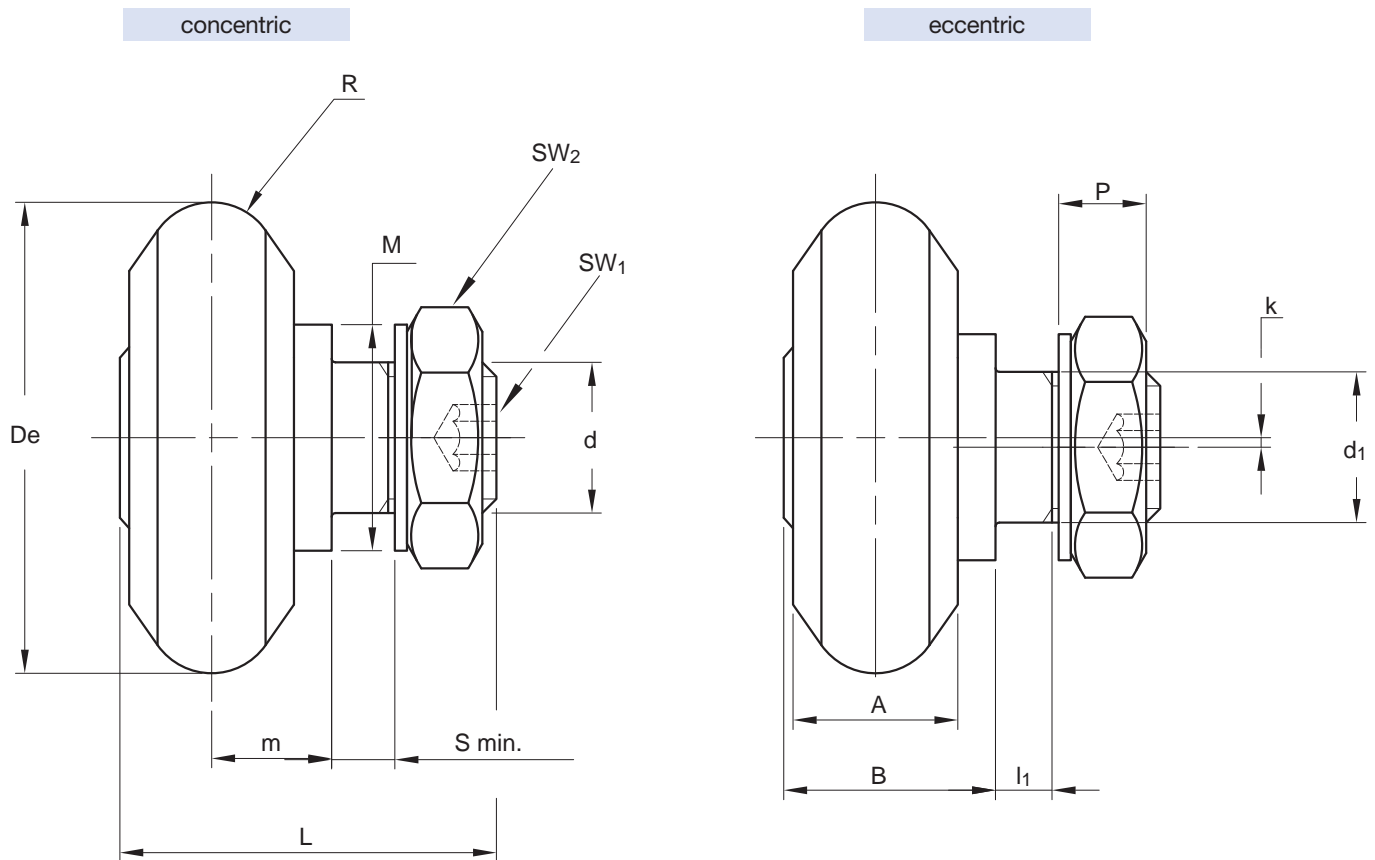

Type		Dimensions (mm)															Guide
concentric	eccentric	De	R	d <sub>1</sub> (1)	d	m	S min.	P	L	A	B	l <sub>1</sub>	M	SW <sub>1</sub>	SW <sub>2</sub>	k	
<b>RCS 28</b>	<b>RCSR 28</b>	23.5	3	8	M8	6.0	2.5	4.8	18.5	6.0	10.0	3.5	12.0	3	13	0.5	<b>LS 28</b>
<b>RCS 43</b>	<b>RCSR 43</b>	35.5	5	10	M10 x 1.25	9.0	4.5	6.0	27.5	11.0	15.0	5.5	17.5	4	16	0.75	<b>LS 43</b>
<b>RCS 63</b>	<b>RCSR 63</b>	50	7	16	M16 x 1.5	12.75	5.5	9.3	40.0	17.5	22.5	6.5	24.0	6	24	1.0	<b>LS 63</b>

Type		Dynamic loads (N)	Limit loads (N)		Life coefficients		Torque-wrench settings (Nm) <sup>2)</sup>	Weight (g)
concentric	eccentric	C <sub>w</sub> <sup>(3)</sup>	radial F <sub>r</sub>	axial F <sub>a</sub>	X	Y		
<b>RCS 28</b>	<b>RCSR 28</b>	2200	1200	330	1	2.7	8	25
<b>RCS 43</b>	<b>RCSR 43</b>	6600	3000	850	1	2.2	20	80
<b>RCS 63</b>	<b>RCSR 63</b>	14200	6500	2200	1	2.8	64	255

1) Tolerance of mounting hole: H7

2) The tightening torques apply to non-lubricated threads; for lubricated threads the values have to be multiplied by 0.8.

3) C<sub>w</sub> = load for lifetime of 100 km

Guide rollers will be supplied with washers and nuts (DIN 439B).

Contact angle  $\alpha$  for the load calculation: 55°

Standard seals type RS

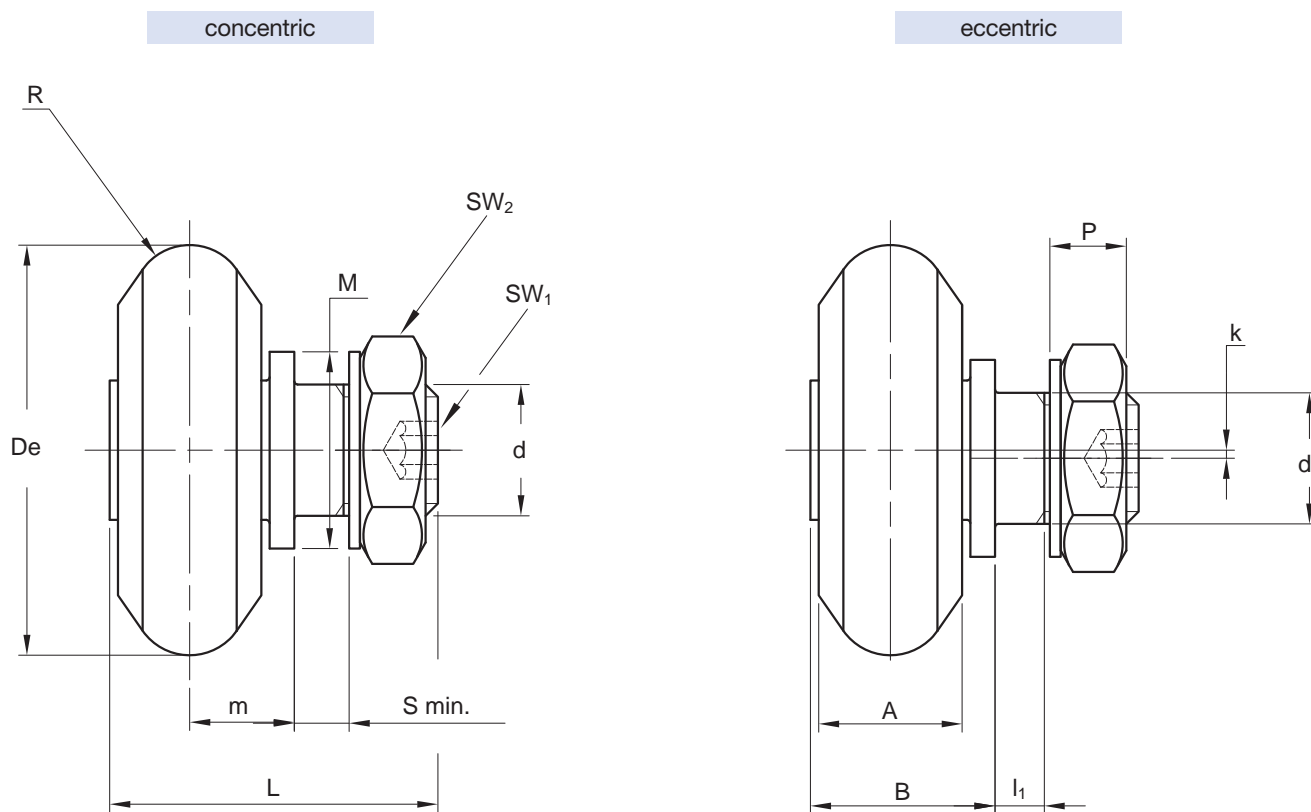

Type		Dimensions (mm)															Guide	
concentric	eccentric	De	R	d <sub>1</sub> <sup>(1)</sup>	d	m min. <sup>(4)</sup>	m max. <sup>(4)</sup>	S min.	P	L	A	B	I <sub>1</sub>	M	SW <sub>1</sub>	SW <sub>2</sub>		k
<b>RAS 28</b>	<b>RASR 28</b>	23.5	3	8	M8	5.5	7.2	2.5	4.8	18.5	7	10	3.5	12	3	13	0.5	<b>LS 28</b>
<b>RAS 43</b>	<b>RASR 43</b>	35.5	5	10	M10 x 1.25	8.2	10.5	4.5	6	27.5	11	15	5.5	17.5	4	16	0.75	<b>LS 43</b>
<b>RAS 63</b>	<b>RASR 63</b>	50	7	16	M16 x 1.5	11.75	15.75	5.5	9.3	40.0	17.5	22.5	6.5	24	6	24	1	<b>LS 43</b>

Type		Dynamic load (N)	Limit load (N)	Torque wrench settings (Nm) <sup>2)</sup>	Weight (g)
concentric	eccentric	Cw <sup>3)</sup>	radiale F <sub>r</sub>		
<b>RAS 28</b>	<b>RASR 28</b>	2200	1200	8	25
<b>RAS 43</b>	<b>RASR 43</b>	6600	3000	20	80
<b>RAS 63</b>	<b>RASR 63</b>	14200	6500	64	255

1) Tolerance of mounting hole: H7

2) The tightening torques apply to non-lubricated threads; for lubricated threads the values have to be multiplied by 0.8.

3) Cw = load for lifetime of 100 km

4) Maximum displacement of dimension m to ensure proper guide roller function and safety.

Guide rollers will be supplied with washers and nuts (DIN 439B).

Contact angle  $\alpha$  for the load calculation: 55°

Standard seals type RS

## Carriages C3 RCS, C3 RAS, C3 RYS

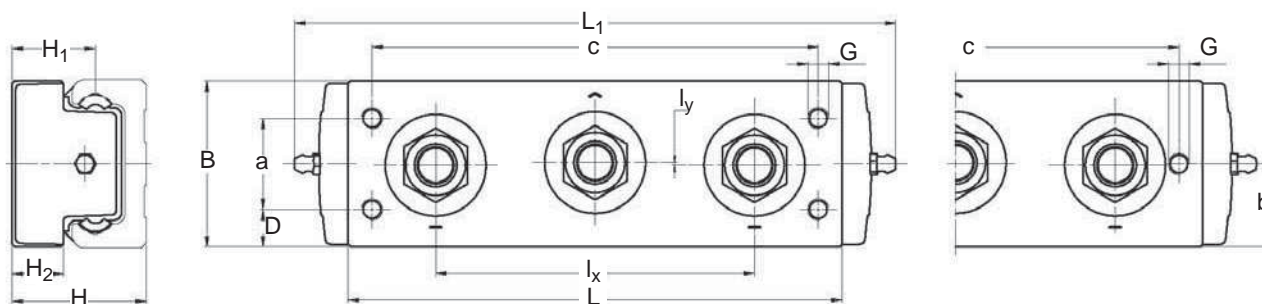

Type		Dimensions (mm)													Weight (kg)	Guide
		L	L <sub>1</sub>	B	l <sub>x</sub>	l <sub>y</sub>	H	H <sub>1</sub>	H <sub>2</sub>	G	a	b	c	k		
short carriage	<b>C3 RCS28 126</b>	88	126	26.5	50	0.5	24	15	9	M5 (2x)	-	13.25	78	0.75	0.13	<b>LS 28</b>
	<b>C3 RCS43 170</b>	130	170	40	78	1	37	22.5	13.5	M8 (2x)	-	20	114	1	0.44	<b>LS 43</b>
	<b>C3 RCS63 226</b>	186	226	60	120	1	50.5	31.25	18.5	M8 (4x)	34	13	168	1.5	1.2	<b>LS 63</b>

Dimensions also apply to C3 RAS and C3 RYS.

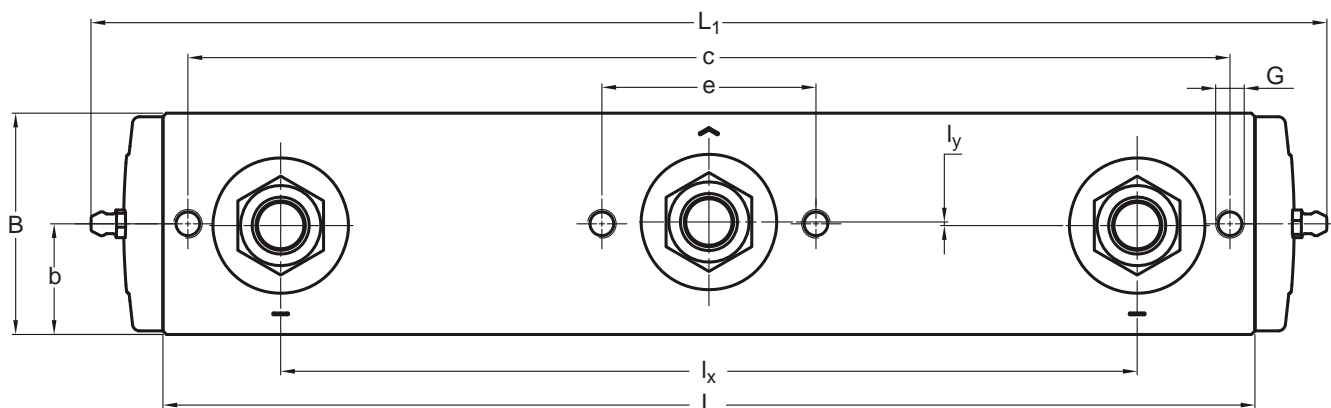

Type		Dimensions (mm)													Weight (kg)	Guide
		L	L <sub>1</sub>	B	l <sub>x</sub>	l <sub>y</sub>	H	H <sub>1</sub>	H <sub>2</sub>	G	b	c	e	k		
long carriage	<b>C3 RCS28 178 A</b>	140	178	26.5	104	0.5	24	15	9	M5	13.25	130	26	0.75	0.15	<b>LS 28</b>
	<b>C3 RCS43 245 A</b>	205	245	41	152	1	37	22.5	13.5	M8	20.5	188	37	1.5	0.50	<b>LS 43</b>

Dimensions also apply to C3 RAS and C3 RYS.

The markings show the contact points with the running surface of the rails.

## Carriages C4 RCS, C4 RAS, C4 RYS

### Roller combinations

The markings show the contact points with the running surface of the rails.

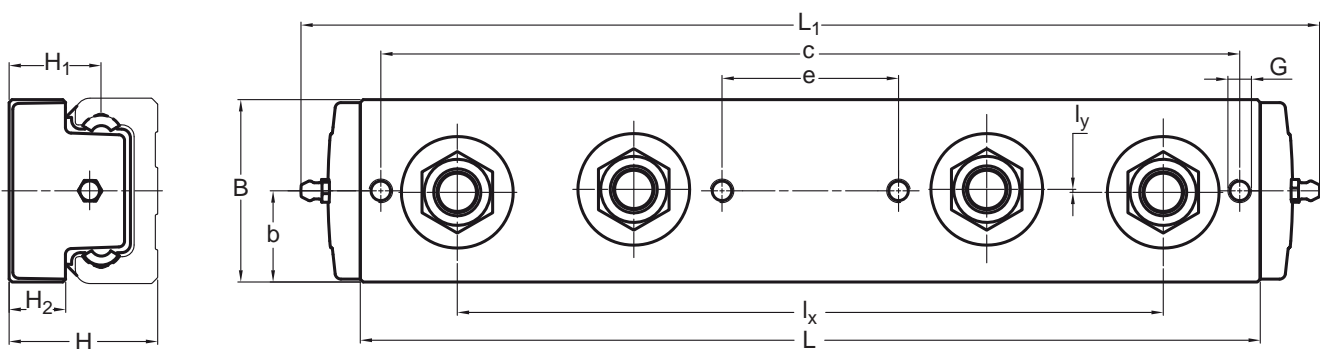
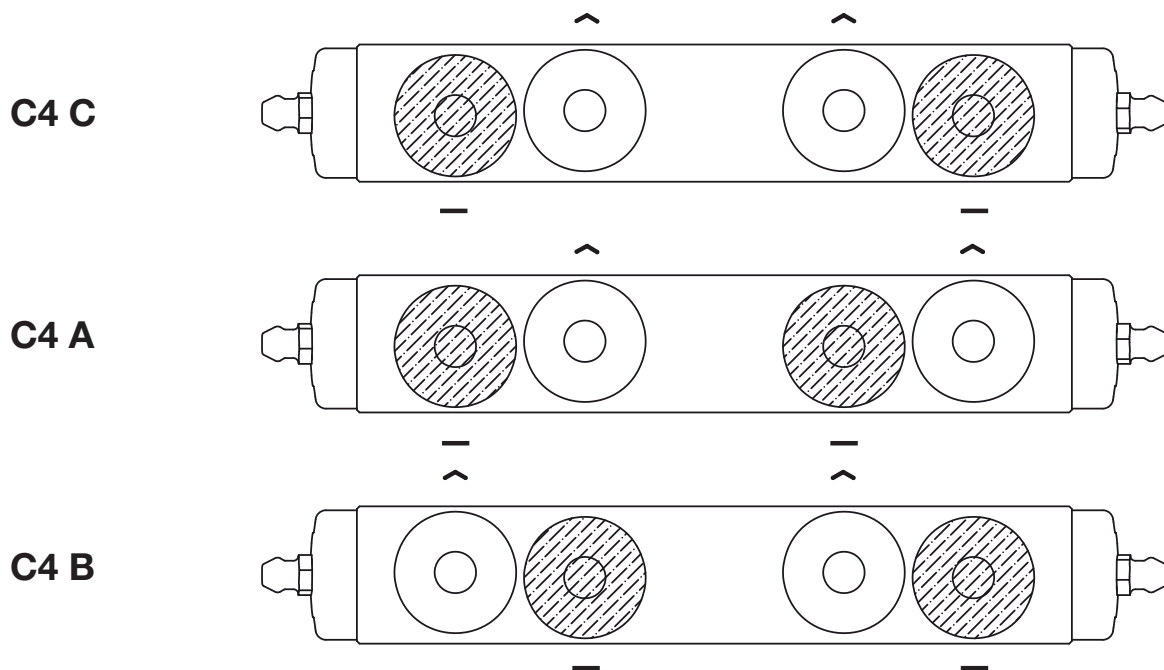

Type	Dimensions (mm)													Weight (kg)	Guide
	L	L <sub>1</sub>	B	l <sub>x</sub>	l <sub>y</sub>	H	H <sub>1</sub>	H <sub>2</sub>	G	b	c	e	k		
C4 RCS28 178 C C4 RCS28 178 A C4 RCS28 178 B	140	178	26.5	104	0.5	24	15	9	M5	13.25	130	26	0.75	0.23	LS 28
C4 RCS43 245 C C4 RCS43 245 A C4 RCS43 245 B	205	245	41	152	1	37	22.5	13.5	M8	20.5	188	37	1	0.58	LS 43

Dimensions also apply to C4 RAS C/A/B and C4 RYS C/A/B.



### Roller combinations

The markings show the contact points with the running surface of the rails.

**C5 A**

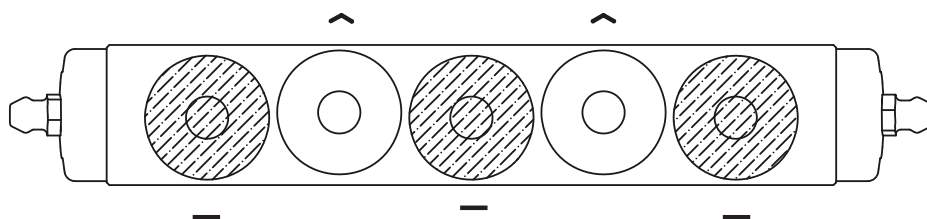

**C5 B**

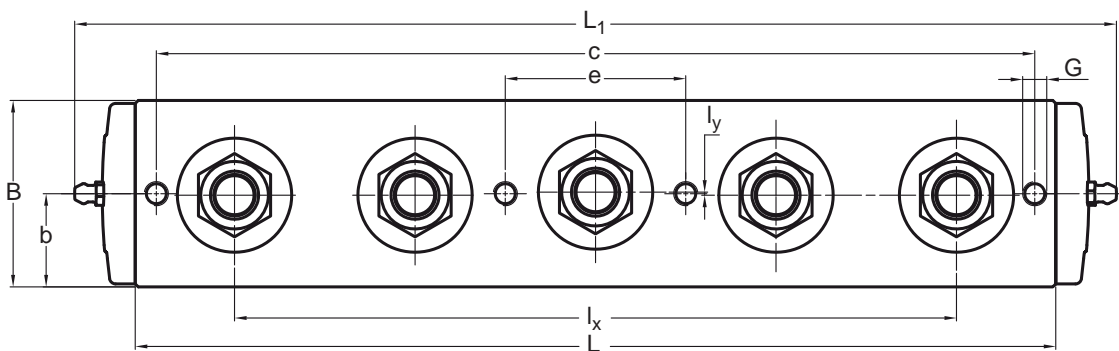
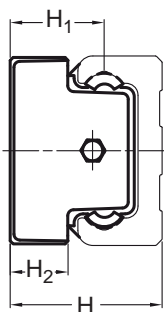
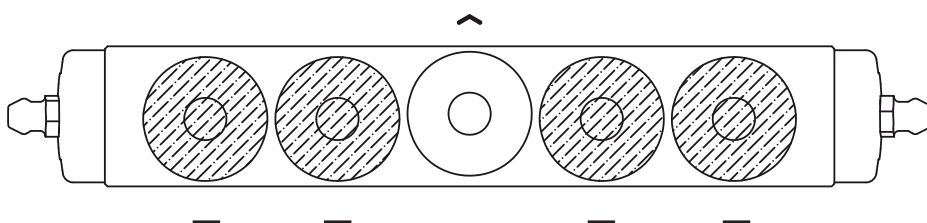

Type	Dimensions (mm)													Weight (kg)	Guide
	L	L <sub>1</sub>	B	l <sub>x</sub>	l <sub>y</sub>	H	H <sub>1</sub>	H <sub>2</sub>	G	b	c	e	k		
<b>C5 RCS28 178 A</b> <b>C5 RCS28 178 B</b>	140	178	26.5	104	0.5	24	15	9	M5	13.25	130	26	0.75	0.25	<b>LS 28</b>
<b>C5 RCS43 245 A</b> <b>C5 RCS43 245 B</b>	205	245	41	152	1	37	22.5	13.5	M8	20.5	188	37	1	0.66	<b>LS 43</b>

Dimensions also apply to C5 RAS A/B and C5 RYS A/B.



# Base-Line

## DC, C Systems

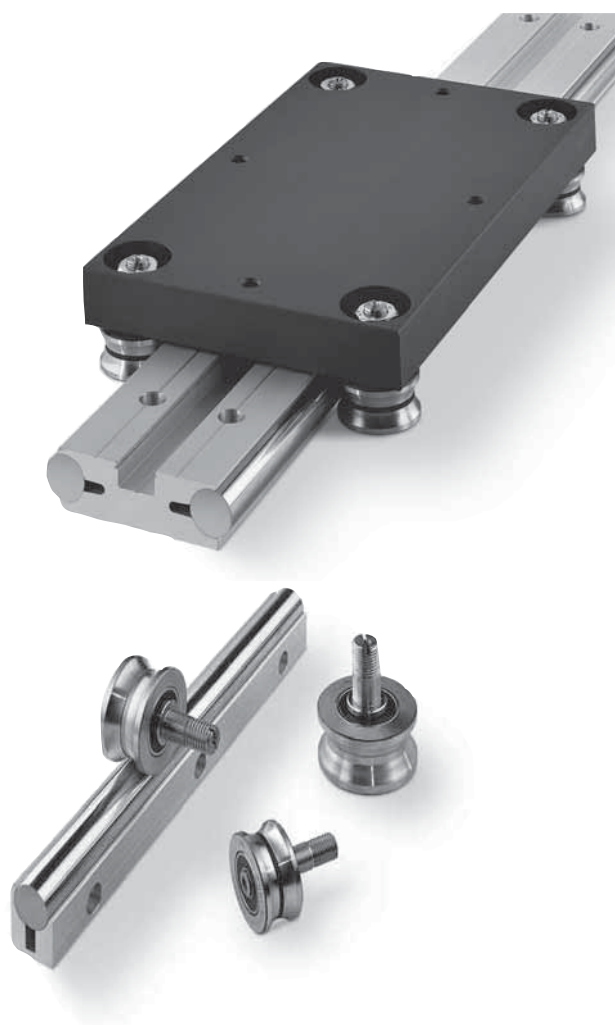

# Base-Line

## DC system

DC system is based on rails, guide rollers and carriages that provide a complete guiding system.

Rails and rollers can be used as single elements.

In most cases the application is based on standard carriages.

The load capacities are tabulated with reference to the axis system showed in the sketch below:

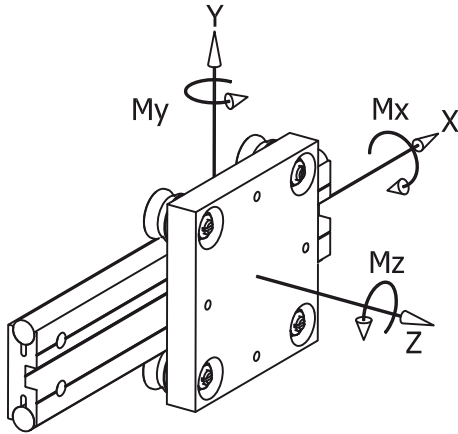

### MAXIMUM LOADS ON SINGLE CARRIAGE

The following table shows the maximum loads that can be applied on a single carriage.

Rails	Carriages	F <sub>y</sub> N	F <sub>z</sub> N	M <sub>x</sub> Nm	M <sub>y</sub> Nm	M <sub>z</sub> Nm
DC 10.54	T4 PFV 25 10 80	1590	800	22	18	35
	T4 PFV 25 10 120	1590	800	22	33	67
DC 16.80	T4 PFV 35 16 165	3570	1800	70	110	225
	T4 PFV 35 16 250	3570	1800	70	190	370
DC 18.65	T4 PFV 35 18 150	3940	1810	55	100	220
	T4 PFV 35 18 250	3940	1810	55	190	420
DC 25.95	T4 PFV 50 25 220	7890	3900	180	320	640
	T4 PFV 50 25 300	7890	3900	180	480	950

The maximum loads are based on the stud and bearing strengths and on a maximum contact pressure, between rail and roller, of 1250 N/mm<sup>2</sup>. The load in the table are considered as acting singularly. For applications with many loads acting at the same time the loads must be reduced.

### BASIC DYNAMIC LOADS OF SINGLE CARRIAGE

The following table shows the nominal loads that correspond to a nominal life of the bearing at 100 km.

The nominal lifetime of the carriage can be estimated from the standard bearing formula

$$L_{10} = (C_i/P_i)^3 \times 100 \text{ km}$$

$C_i$  is the basic dynamic load capacity in a specific direction  $i$  and  $P_i$  is the external load applied in the same specific direction.

Rails	Carriages	C <sub>y</sub> N	C <sub>z</sub> N	CM <sub>x</sub> Nm	CM <sub>y</sub> Nm	CM <sub>z</sub> Nm
DC 10.54	T4 PFV 25 10 80	3700	1200	32	27	84
	T4 PFV 25 10 120	3700	1200	32	51	158
DC 16.80	T4 PFV 35 16 165	9000	2950	115	185	570
	T4 PFV 35 16 250	9000	2950	115	310	950
DC 18.65	T4 PFV 35 18 150	9000	2950	95	165	510
	T4 PFV 35 18 250	9000	2950	95	315	970
DC 25.95	T4 PFV 50 25 220	17500	6100	290	500	1400
	T4 PFV 50 25 300	17500	6100	290	750	2150

### Calculation example: carriage loaded with an external load F

Carriage T4 PFV 50 25 220;  $F = 2000 \text{ N}$ .

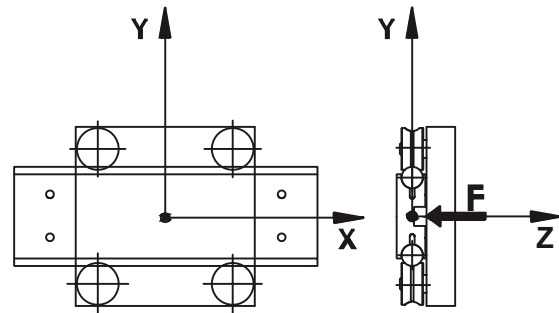

The external load  $F$  acts in the z-axis direction:

$$P_z = F = 2000 \text{ N}$$

In the table of the “maximum loads” you find that the load capacity  $F_z$  for carriage T4 PFV 50 25 220 is equal to 3900 N, so the system is validated against breakage.

To estimate the system lifetime we proceed as follows: from the table of the “basic dynamic loads” we see that  $C_z$ , for the carriage T4 PFV 50 25 220, is equal to 6100 N.

The nominal lifetime will be:

$$L_{10} = (6100/2000)^3 \times 100 = 2837 \text{ km}$$

Important notes:

- in order to reach the calculated lifetime it is important to lubricate the rails;
- for load configurations with many loads and moments acting at the same time in different directions, please refer to the calculation examples you can find at the beginning of the catalogue or contact our Technical department.

# Base-Line

## Guide rails DC

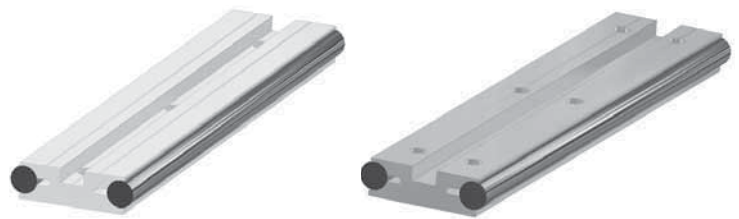

DC 16.80 and DC 18.65  
DC 10.54

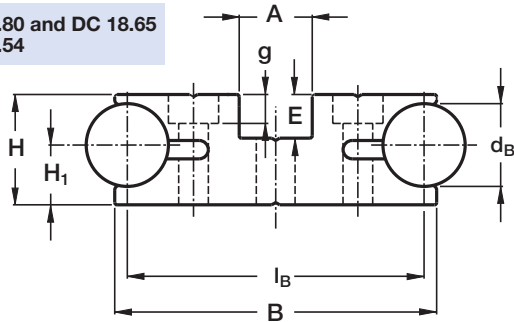

DC 25.95

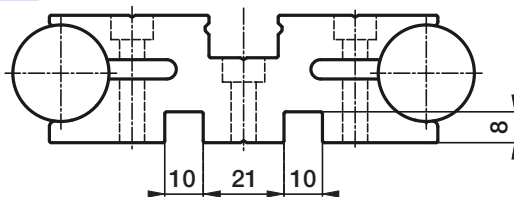

DC...S

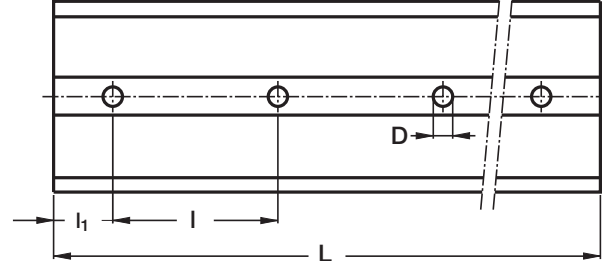

DC...D

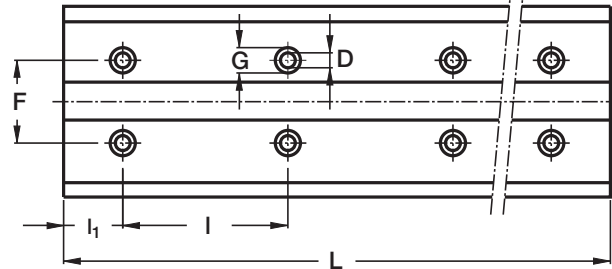

Type	Dimensions (mm)													Moments of inertia <sup>(2)</sup> (cm <sup>4</sup> )		Weight (kg/m)
	d <sub>B</sub>	l <sub>B</sub>	B	H	H <sub>1</sub>	A	E	D	G	g	F	l	l <sub>1</sub>	J <sub>x</sub>	J <sub>y</sub>	
DC 10.54 S <sup>(3)</sup>	10	54	57	19.5	13	25	10.5	6.5	-	-	-	150	30	2.16	20.5	3.15
DC 10.54 D <sup>(3)</sup>	10	54	57	19.5	13	25	10.5	4.5	8	4.2	36	150	30	2.16	20.5	3.15
DC 16.80 S <sup>(3)</sup>	16	80	86	25.5	14.5	18	9.5	8.5	-	-	-	150	30	9.6	85	7.1
DC 16.80 D <sup>(3)</sup>	16	80	86	25.5	14.5	18	9.5	6.5	11	6.3	54	150	30	9.6	85	7.14
DC 18.65 S	18	65	70.5	24	13	16	9.5	8.5	-	-	-	150	30	6.1	34.7	7
DC 18.65 D	18	65	70.5	24	13	16	9.5	6.5	11	6.3	36	150	30	6.1	34.7	7.14
DC 25.95 S <sup>(3)</sup>	25	95	101	33	18	19	13	10.5	-	-	-	150	30	21.8	142.2	13.5
DC 25.95 D <sup>(3)</sup>	25	95	101	33	18	19	13	6.5	11	6.3	58	150	30	21.8	142.2	13.53

max length in single element L=6000 <sup>(1)</sup>

1) Longer rails are supplied in sections with ground butt joints and, on request, with pin connection

2) Inertia value based on equivalent aluminium yield 70000 N/mm<sup>2</sup>

3) Available with stainless steel shafts

### Hole layout

- holes according to catalogue (**SB**)
- finishes to drawing (**NZ**)
- without holes (**NF**)

### Optional features

- ground one end (**R**)
- ground both ends (**RR**)
- stainless steel shafts (**NX**)
- chromium plated shafts (**CH**)

Example of standard designation: **DC2595S 2010 SB NX**

See page 17 for standard codification

# Base-Line

## Guide rails C

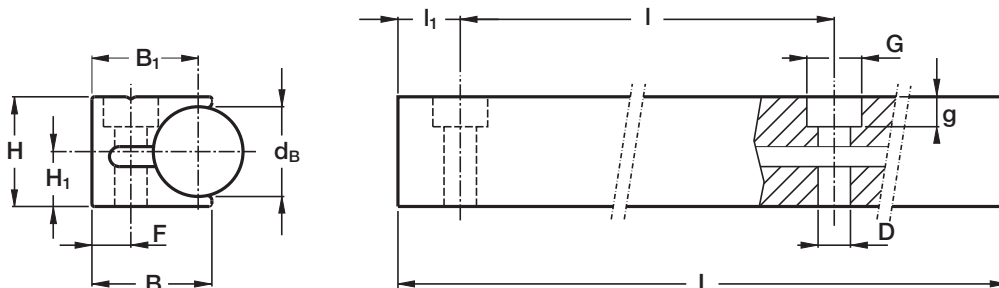

Type	Dimensions (mm)											Moments of inertia <sup>(2)</sup> (cm <sup>4</sup> )		Weight (kg/m)
	d <sub>B</sub>	B	B <sub>1</sub>	H	H <sub>1</sub>	D	G	g	F	I	I <sub>1</sub>	J <sub>x</sub>	J <sub>y</sub>	
<b>C 10</b> <sup>(3)</sup>	10	16.9	15.4	14.5	8	4.5	8	4.2	6.5	100	30	0.4	0.3	1.1
<b>C 18</b>	18	24	21.3	22	11	6.5	11	6.3	7.8	150	50	1.7	1.1	2.8
<b>C 22</b>	22	28	25	26.5	13.5	6.5	11	6.3	9	160	50	3.5	2	4.1
<b>C 30</b> <sup>(3)</sup>	30	36	32.5	36	19	9	15	8.3	11.5	180	60	11.1	5.6	7.6

max length in single element L=6000 <sup>(1)</sup>

1) Longer rails are supplied in sections with ground butt joints and, on request, with pin connection

2) Inertia value based on equivalent aluminium yield 70000 N/mm<sup>2</sup>

3) Available with stainless steel shafts

### Hole layout

- holes according to catalogue (**SB**)
- finishes to drawing (**NZ**)
- without holes (**NF**)

### Optional features

- ground one end (**R**)
- ground both ends (**RR**)
- stainless steel shafts (**NX**)
- chromium plated shafts (**CH**)

Example of standard designation: **C10 2060 SB**

See page 17 for standard codification



## Guide rollers PFV with “gothic arch” profile

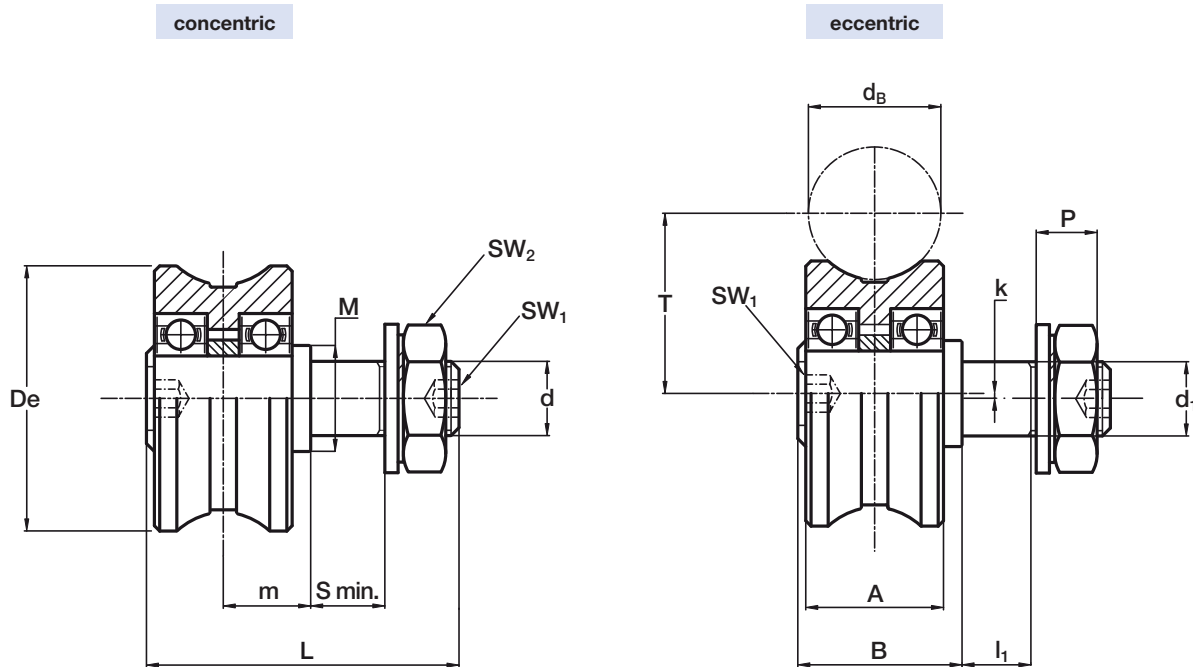

Type		Dimensions (mm)															Recommended pairings	
concentric	eccentric	De	dB	d <sub>1</sub> <sup>(1)</sup>	d	T	m	S min.	P	L	A	B	l <sub>1</sub>	M	SW <sub>1</sub>	SW <sub>2</sub>		k
<b>PFV 25.10</b> <sup>(3)</sup>	<b>PFVR 25.10</b> <sup>(3)</sup>	25	10	8	M8x1.25	15.5	7.5	11	9	34.8	12	14.8	10	12	4	13	0.75	<b>C 10/DC 10.54</b>
<b>PFV 35.16</b> <sup>(3)</sup>	<b>PFVR 35.16</b> <sup>(3)</sup>	35	16	10	M10x1.25	23.0	12.0	12	10.7	45.3	18	22.3	11	15	4	17	0.75	<b>DC 16.80</b>
<b>PFV 35.18</b> <sup>(3)</sup>	<b>PFVR 35.18</b> <sup>(3)</sup>	35	18	10	M10x1.25	24	12	12	10.7	45.3	18	22.3	11	15	4	17	0.75	<b>C 18/DC 18.65</b>
<b>PFV 43.22</b> <sup>(3)</sup>	<b>PFVR 43.22</b> <sup>(3)</sup>	43	22	12	M12x1.50	29.0	14.0	13	12.5	52.0	23	27.0	12	18	5	19	1.75	<b>C 22</b>
<b>PFV 50.25</b> <sup>(3)</sup>	<b>PFVR 50.25</b> <sup>(3)</sup>	50	25	14	M14x1.5	34	16.5	14	13.5	59	26	31	13	20	6	22	1	<b>DC 25.95</b>
<b>PFV 60.30</b>	<b>PFVR 60.30</b>	60	30	16	M16x1.50	41.0	19.5	17	14.0	69.5	31	36.5	16	30	8	24	1.75	<b>C 30</b>

Type		Dynamic load (N)	Limit loads (N)		Life coefficients		Torque wrench <sup>(2)</sup> settings (Nm)	Weight (g)
		C <sub>w</sub> <sup>(4)</sup>	radial F <sub>r</sub>	axial F <sub>a</sub>	X	Y		
<b>PFV 25.10</b>	<b>PFVR 25.10</b>	1 850	1 080	200	1	4.4	8	42
<b>PFV 35.16</b>	<b>PFVR 35.16</b>	4 550	2 120	430	1	4.4	20	115
<b>PFV 35.18</b>	<b>PFVR 35.18</b>	4 570	2 120	430	1	4.4	20	113
<b>PFV 43.22</b>	<b>PFVR 43.22</b>	7 600	3 150	780	1	4.3	26	210
<b>PFV 50.25</b>	<b>PFVR 50.25</b>	8 800	4 240	940	1	4	44	335
<b>PFV 60.30</b>	<b>PFVR 60.30</b>	15 700	5 360	1 350	1	4.3	64	570

1) Housing bore tolerance: H7

2) The torque wrench settings are given for non-lubricated threads; for lubricated threads, multiply figure by 0.8

3) Available in stainless steel (suffix **NX**)

4) C<sub>w</sub> basic load for 100 km

5) The guide rollers are complete with self-locking washers and hexagonal nut (DIN 439B) for fitting

6) Pressure angle α for load calculation: 60°

7) NBR seals, RS type

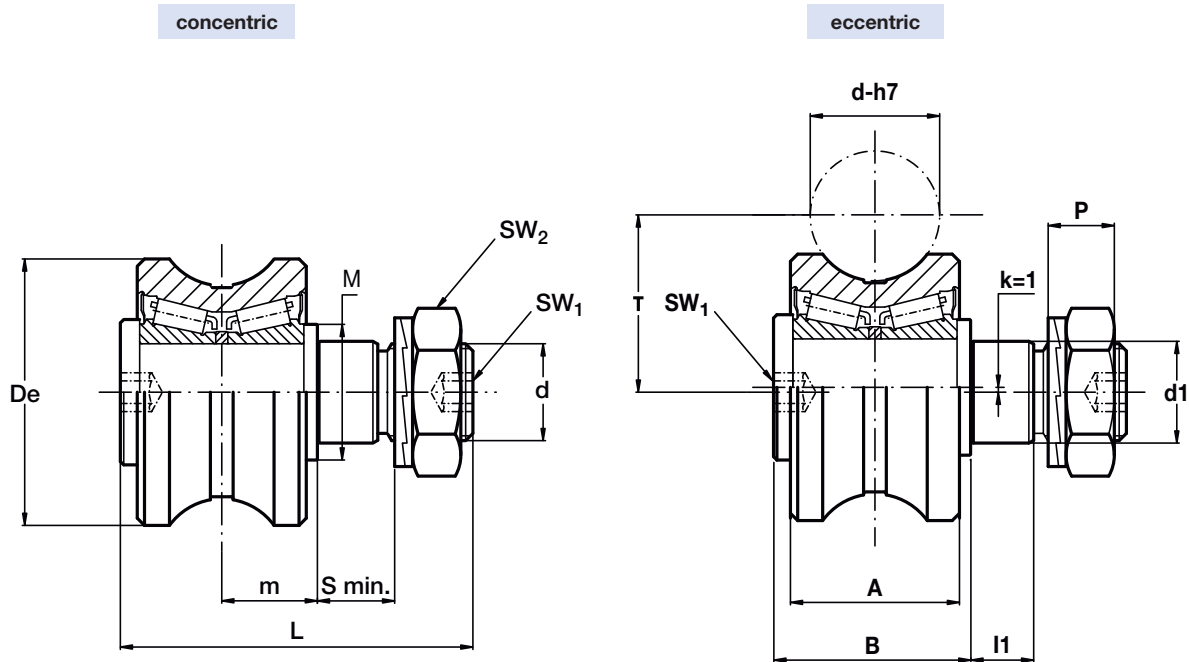

Type		Dimensions (mm)															
concentric	eccentric	De	d-h7	d <sub>1</sub> <sup>(1)</sup>	d	T	m	S min.	P	L	A	B	l <sub>1</sub>	M	SW <sub>1</sub>	SW <sub>2</sub>	k
<b>RKO 55.20</b>	<b>RKOR 55.20</b>	55	20	21	M 20 x 1.5	32.9	19.8	15	13.4	73	35	41	14	28	8	30	1
<b>RKO 55.25</b>	<b>RKOR 55.25</b>	55	25	21	M 20 x 1.5	34.3	19.8	15	13.4	73	35	41	14	28	8	30	1
<b>RKO 62.30</b>	<b>RKOR 62.30</b>	62	30	21	M 20 x 1.5	39.6	19.8	15	13.4	73	35	41	14	28	8	30	1
<b>RKO 80.40</b>	<b>RKOR 80.40</b>	79	40	36	M 30 x 1.5	50.7	27.8	19	19.6	100	45	55	18	44	12	46	1

Type		Dynamic load (N)	Limit loads (N)		Life coefficients		Torque wrench (Nm) <sup>(2)</sup> settings	Weight (kg)
		C <sub>w</sub> <sup>(4)</sup>	radial F <sub>r</sub>	axial F <sub>a</sub>	X	Y		
<b>RKO 55.20</b>	<b>RKOR 55.20</b>	40 750	11 900	3 550	1	2.88	80	0.6
<b>RKO 55.25</b>	<b>RKOR 55.25</b>	40 750	11 900	3 450	1	2.90	80	0.6
<b>RKO 62.30</b>	<b>RKOR 62.30</b>	46 000	11 900	3 150	1	2.65	80	0.7
<b>RKO 80.40</b>	<b>RKOR 80.40</b>	64 850	31 300	10 100	1	2.59	300	1.6

1) Housing bore tolerance: H7

2) Torque wrench settings are given for non-lubricated threads; for lubricated threads, multiply figure by 0.8

3) Standard seals: material NBR, type RS

4) On request, the guide rollers can be supplied with Viton seals for operating temperatures up to 120°C (suffix **V**)

5) C<sub>w</sub> basic load for 100 km

6) The guide rollers is complete with self-locking washers and hexagonal nut for fitting

7) Pressure angle α for load calculation: 70°C

# Base-Line

## Carriages T4PFV

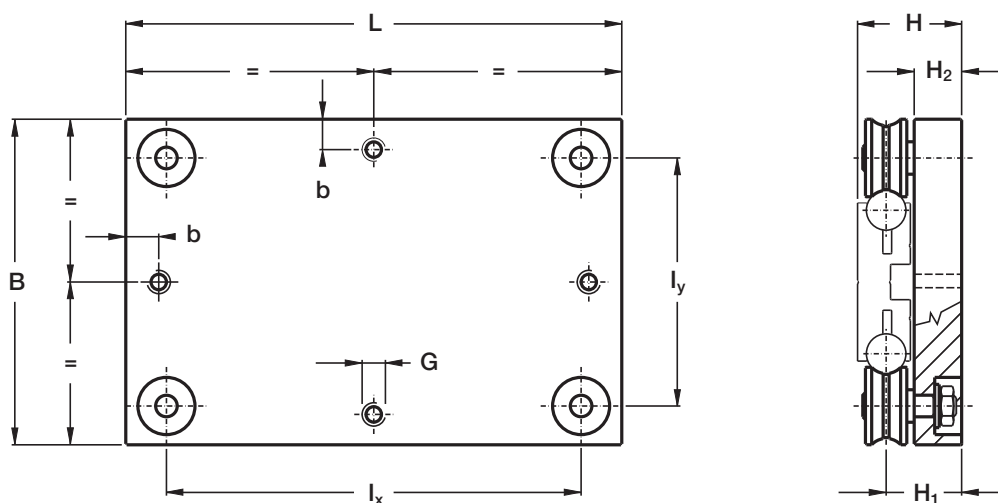

Type	Dimensions (mm)									Weight (kg)	Recommended pairings
	L	B	I <sub>x</sub>	I <sub>y</sub>	H	H <sub>1</sub>	H <sub>2</sub>	G	b		
T4PFV 25 10 80 <sup>(1)</sup>	80	120	45	85	41	28	20.5	M8	15	0.69	DC 10.54
T4PFV 25 10 120 <sup>(1)</sup>	120	120	85	85	41	28	20.5	M8	15	0.96	DC 10.54
T4PFV 35 16 165 <sup>(1)</sup>	165	165	126	126	50.5	36	24	M8	15	2.1	DC 16.80
T4PFV 35 16 250 <sup>(1)</sup>	250	165	211	126	50.5	36	24	M8	15	3.1	DC 16.80
T4PFV 35 18 150 <sup>(1)</sup>	150	150	113	113	49	36	24	M8	15	1.8	DC 18.65
T4PFV 35 18 250 <sup>(1)</sup>	250	150	213	113	49	36	24	M8	15	2.8	DC 18.65
T4PFV 50 25 220 <sup>(1)</sup>	220	220	163	163	63.5	45.5	29	M10	20	5	DC 25.95
T4PFV 50 25 300 <sup>(1)</sup>	300	220	243	163	63.5	45.5	29	M10	20	6.4	DC 25.95

1) Available with stainless steel guide rollers (**NX**)

2) Carriages are complete with guide rollers

3) Pressure angle  $\alpha$  for load calculation: 60°

# Base-Line

## Wiper NAID

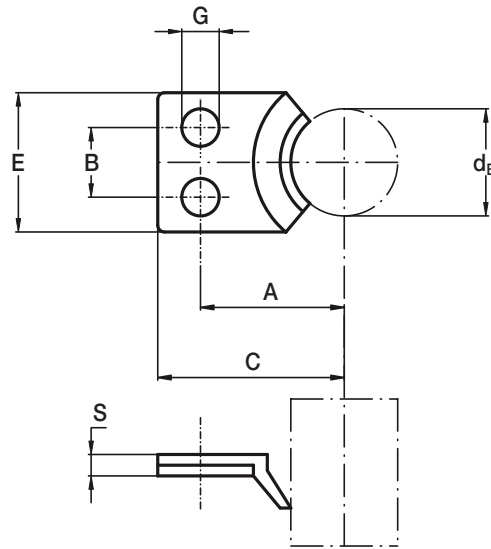
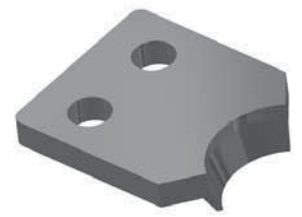

Type	Dimensions (mm)								Recommended pairings
	$d_B$	$E$	$C$	$A$	$B$	$G$	$A$	$S$	
<b>NAID 010</b>	10	13	17.5	13.5	6.5	3.5	12	3	<b>C 10</b>
<b>NAID 016</b>	16	20	26.5	20.5	10	4.5	18	3	<b>DC 16.80</b>
<b>NAID 018</b>	18	20	26.5	20.5	10	4.5	18	3	<b>C 18/DC 18.65</b>
<b>NAID 022</b>	22	24	30.0	24.0	14	4.5	23	3	<b>C 22</b>
<b>NAID 025</b>	25	28	37.5	30.5	18	4.5	26	3	<b>DC 25.95</b>
<b>NAID 030</b>	30	32	45.5	37.5	20	5.5	31	3	<b>C 30</b>

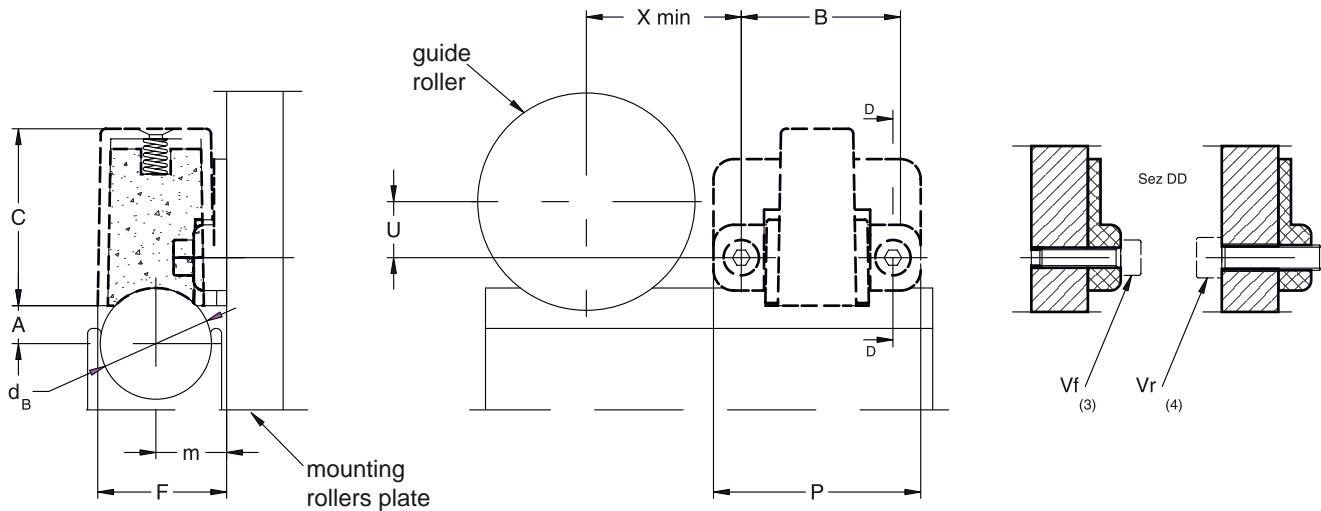

Type	Dimensions (mm)											Weight (g)	Suggested combinations
	X	U	B	F	m	d <sub>B</sub>	A	C	P	Vf	Vr		
<b>LUBC 25.10</b>	18	4.5	25	13	7.5	10	3	22	32.5	M3x12	M4	10	<b>PFV 25.10</b>
<b>LUBC 35.16</b>	23	9.5	25	22	12	16	5.5	32	32.5	M3x12	M4	15	<b>PFV 35.16</b>
<b>LUBC 35.18</b>	23	9.5	25	22	12	18	6.5	32	32.5	M3x12	M4	15	<b>PFV 35.18</b>
<b>LUBC 43.22</b>	29	12	30	25.5	14	22	22	35	41	M4x12	M5	30	<b>PFV 43.22</b>
<b>LUBC 50.25</b>	32.5	15.5	30	30.5	16.5	25	9	45	41	M4x12	M5	35	<b>PFV 50.25</b>
<b>LUBC 60.30</b>	37.5	20.5	30	36.5	19.5	30	11	50	41	M4x12	M5	40	<b>PFV 60.30</b>

- 1) The lubricator is supplied with the felt already lubricated. The lubricant has a mineral oil base
- 2) At the mounting, insert the screws inside the rollers plate, without tightening them, adjust the height of the plastic part in order to put it in contact with the raceways and then block it
- 3) The screws Vf for the frontal mounting are included in the packaging. Arrange two thread holes for dimension Vf in the mounting rollers plate
- 4) The screw for the mounting on the nut side of the roller are not included in the packaging. Arrange on the mounting rollers plate the holes in order to insert the screws Vr

### Optional features

- felt without lubricant (D)

# Base-Line

## Mounting examples

Oxy fuel cutting machine  
Base-Line C and DC

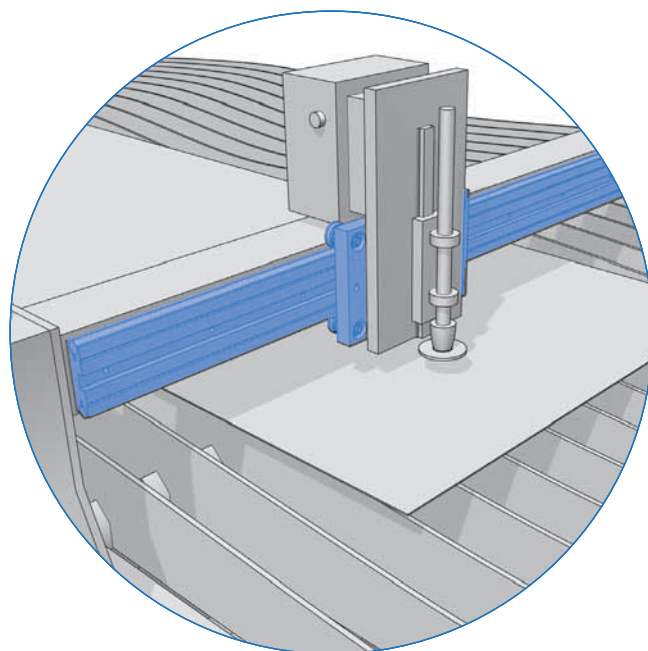
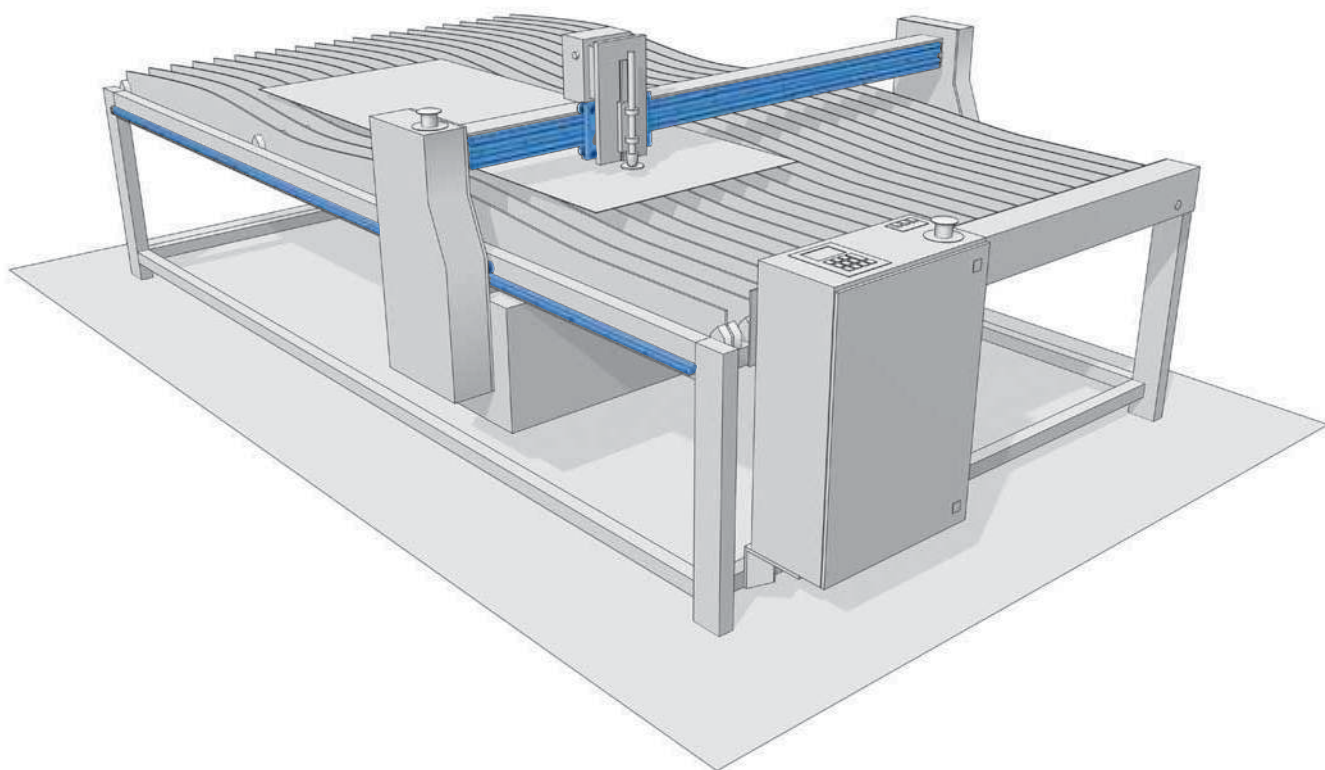

# Base-Line

## FWS, FWH System

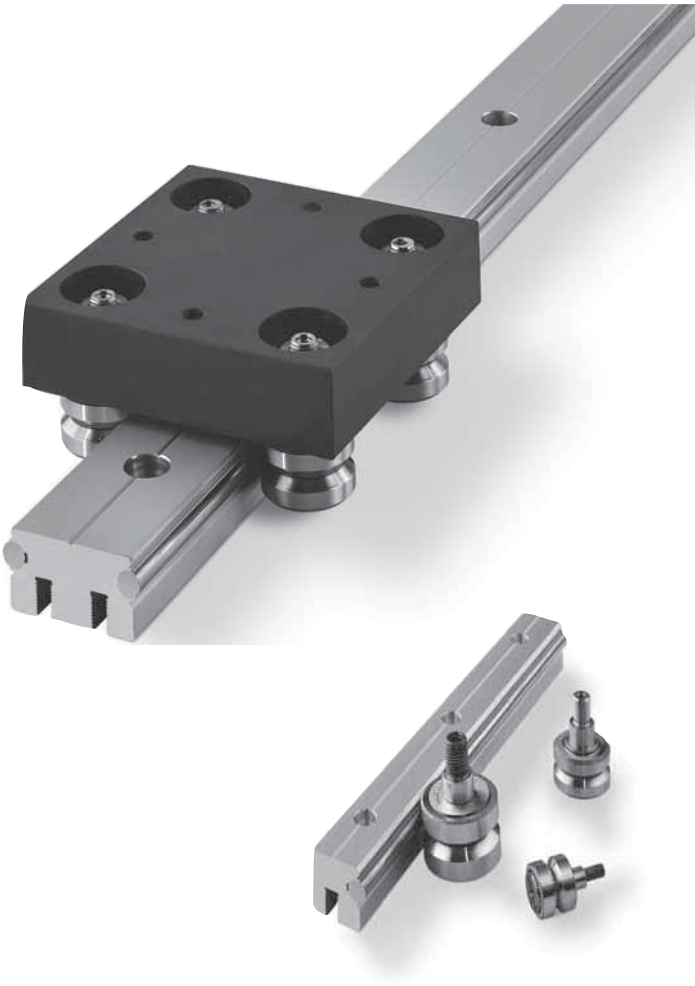

# Base-Line

## Guide rails FWS

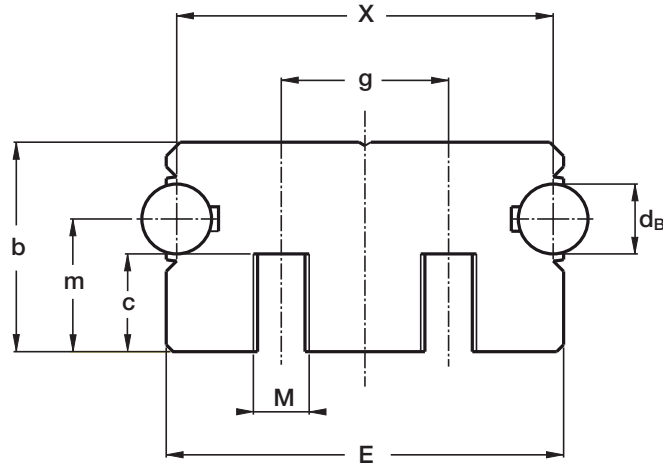

Type	Dimensions (mm)							
	$d_B$	X	M	g	E	b	m	c
<b>FWS 22</b>	6	34	M 5	16	36	20	14	10
<b>FWS 32</b>	8	42	M 6	20	45	25	17	12
<b>FWS 40</b>	10	54	M 8	24	57	30	19	14
<b>FWS 52</b>	12	66	M 10	32	69	36	24	18

single guide element L=4500 <sup>(1)</sup>

Type	Screw distance max.			Moments of inertia <sup>(2)</sup> cm <sup>4</sup>		Weight (kg/m)
	for 2 screw channels		for additional holes (NZ)	$J_x$	$J_y$	
	Distance (mm)	Torque wrench settings (Nm)	Distance (mm)			
<b>FWS 22</b>	190	2	220	2.07	6.01	2
<b>FWS 32</b>	210	5	240	5.10	14.56	3.3
<b>FWS 40</b>	250	15	280	11.01	35.26	5
<b>FWS 52</b>	250	23	280	22.85	74.12	7.2

1) Longer rails are supplied in sections with ground butt joints at the rods

2) Inertia value based on equivalent aluminium yield 70000 N/mm<sup>2</sup> including shafts

### Hole layout

- finishes to drawing (**NZ**)
- without holes (**NF**)

### Optional features

- ground one end (**R**)
- ground both ends (**RR**)
- stainless steel shafts (**NX**)

Example of standard designation: **FWS32/1500 NF**

See page 17 for standard codification



# Base-Line

## Guide rails FWH

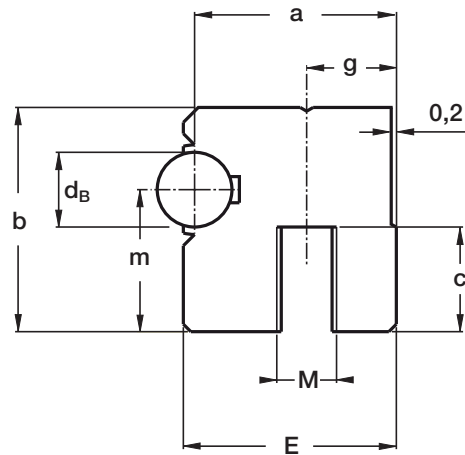

Type	Dimensions (mm)							
	$d_B$	a	M	g	E	b	m	c
<b>FWH 22</b>	6	17	M5	8	18	20	14	10
<b>FWH 32</b>	8	21	M5	10	22.5	25	17	12
<b>FWH 40</b>	10	27	M8	12	28.5	30	19	14
<b>FWH 52</b>	12	33	M10	16	34.5	36	24	18

Maximum length of single guide element L = 4 500 <sup>(1)</sup>

Type	Screw distance max.			Moments of inertia <sup>(2)</sup> cm <sup>4</sup>		Weight (kg/m)
	for 1 screw channels		for additional holes	$J_x$	$J_y$	
	Distance (mm)	Torque wrench settings (Nm)	Distance (mm)			
<b>FWH 22</b>	70	2	120	1.02	0.83	1
<b>FWH 32</b>	60	5	130	2.55	2.05	1.6
<b>FWH 40</b>	97	15	150	5.71	4.75	2.5
<b>FWH 52</b>	120	23	150	10.12	11.85	3.6

1) Longer rails are supplied in sections with ground butt joints

2) Inertia value based on equivalent aluminium yield 70000 N/mm<sup>2</sup> including shafts

### Hole layout

- finishes to drawing (**NZ**)
- without holes (**NF**)

### Optional features

- ground one end (**R**)
- ground both ends (**RR**)
- stainless steel shafts (**NX**)

Example of standard designation: **FWH32/1500 NF**

See page 17 for standard codification

# Base-Line

## Guide rollers FR..EU

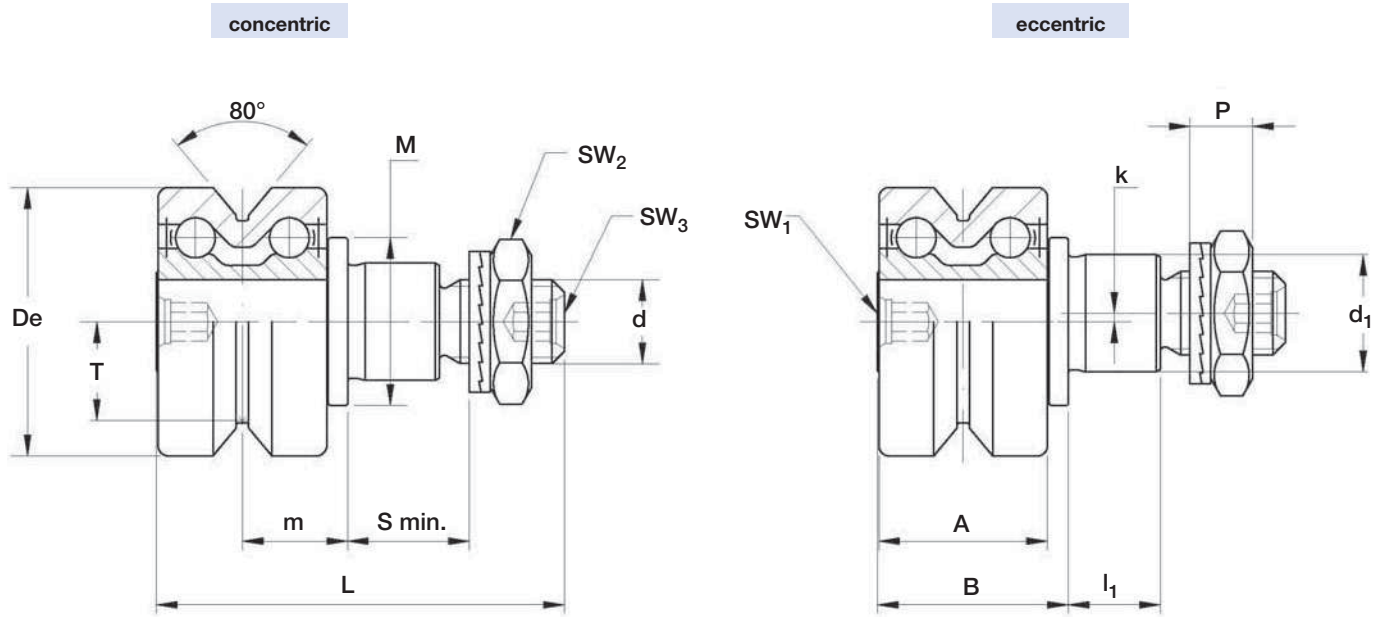

The sides of the race are slightly convex

Type		Dimensions (mm)															
concentric	eccentric	De	d <sub>1</sub> (1)	d	T	m	S <sub>min</sub>	P	L	A	B	l <sub>1</sub>	M	SW <sub>1</sub>	SW <sub>2</sub>	SW <sub>3</sub>	k
FR 22 EU <sup>(4)</sup>	FRR 22 EU <sup>(4)</sup>	22	9	M 6 x 1	7.7	9.4	9	6.5	36.8	15	18	8	14	4	10	3	0.8
FR 32 EU <sup>(4)</sup>	FRR 32 EU <sup>(4)</sup>	32	14	M 10 x 1.25	11.8	12.6	12	8.5	48.9	20.2	22.9	11	20	4	17	4	1
FR 40 EU <sup>(4)</sup>	FRR 40 EU <sup>(4)</sup>	40	16	M 12 x 1.5	14.6	15.5	12	10.4	58.5	25	29.5	11	22	5	19	5	1
FR 52 EU	FRR 52 EU	52	21	M 16 x 1.5	19.1	19.8	15	11.4	69.5	32	36.5	14	28	6	24	6	1.5

Type		Dynamic load (N)	Limit loads (N)		Life coefficients		Torque wrench settings <sup>(2)</sup> (Nm)	Weight (g)
		C <sub>w</sub> <sup>(4)</sup>	radial F <sub>r</sub>	axial F <sub>a</sub>	X	Y		
FR 22 EU	FRR 22 EU	2 900	1 400	420	1	2	3	45
FR 32 EU	FRR 32 EU	5 800	2 000	800	1	1.9	20	125
FR 40 EU	FRR 40 EU	8 500	3 650	1 400	1	1.9	26	230
FR 52 EU	FRR 52 EU	11 700	8 500	3 000	1	1.9	64	510

1) Housing bore tolerance: H7

2) The torque wrench settings are given for non-lubricated threads; for lubricated threads, multiply figure by 0.8

3) C<sub>w</sub> basic load for 100 km

4) FR/R 22, 32, 40 are available in stainless steel (NX)

The guide rollers are complete with self-locking washers and hexagonal nut (DIN439B) for fitting

Pressure angle  $\alpha$  for load calculation: 40°

NBR seals RS type

# Base-Line

## Guide Rollers FR..EU AS, FR..EU AZ

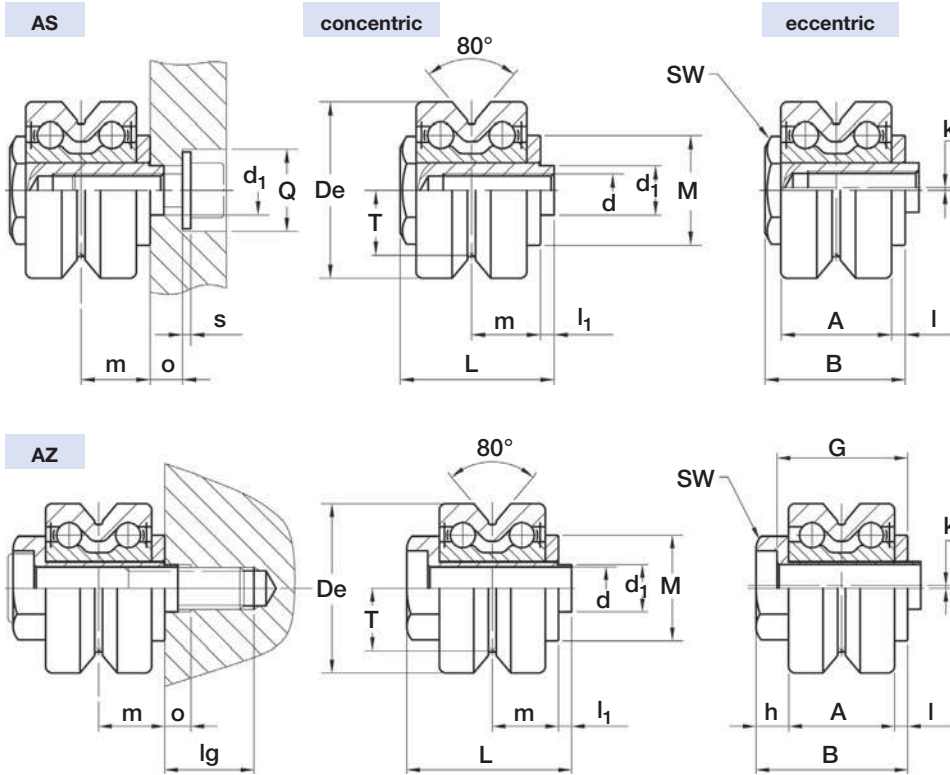

Type		Dimensions (mm)																		
concentric	eccentric	De	d1 <sup>(1)</sup>	d <sup>(2)</sup>	T	m	L	A	B	l <sub>1</sub>	I	h	M	SW	G	o	Q	lg <sup>(6)</sup>	s	k
FR 22 EU AS <sup>(5)</sup>	FRR 22 EU AS <sup>(5)</sup>	22	6	M 5	7.7	9.4	21.8	15	19.8	2	1.9	-	14	10	-	4.5	10	-	0	0.5
FR 32 EU AS <sup>(5)</sup>	FRR 32 EU AS <sup>(5)</sup>	32	9	M 6	11.8	12.6	28.1	20.2	25.6	2.5	2.5	-	20	17	-	6	15	-	1.5 <sup>(4)</sup>	0.5
FR 40 EU AS <sup>(5)</sup>	FRR 40 EU AS <sup>(5)</sup>	40	11	M 8	14.6	15.5	33.5	25	31	2.5	3	-	22	22	-	6.5	20	-	2 <sup>(4)</sup>	1
FR 52 EU AS	FRR 52 EU AS	52	16	M10	19.1	19.8	43.2	32	40	3.2	3.8	-	28	27	-	8	24	-	2.5 <sup>(4)</sup>	1.5
FR 22 EU AZ <sup>(5)</sup>	FRR 22 EU AZ <sup>(5)</sup>	22	6	5.1	7.7	9.4	23.9	15	21.9	2	1.9	5	14	11	18.9	4	-	13	-	0.5
FR 32 EU AZ <sup>(5)</sup>	FRR 32 EU AZ <sup>(5)</sup>	32	9	8.1	11.8	12.6	31.4	20.2	28.9	2.5	2.5	6.2	20	17	24.9	5	-	17	-	0.5
FR 40 EU AZ <sup>(5)</sup>	FRR 40 EU AZ <sup>(5)</sup>	40	11	10.1	14.6	15.5	38	25	35.5	2.5	3	7.5	22	22	30.5	5	-	26	-	0.8
FR 52 EU AZ	FRR 52 EU AZ	52	16	14.1	19.1	19.8	49.5	32	46.3	3.2	3.8	10.5	28	27	39.3	5.5	-	27	-	1.5

Guide roller size	Dynamic load (N)	Limit loads (N)		Life coefficients		Weight AS (g)	Weight AZ (g)	On re quest for AZ screw DIN7984
	Cw <sup>(3)</sup>	radial F <sub>r</sub>	axial F <sub>a</sub>	X	Y			
22	2 900	470	210	1	2	33	31	M 5 x 30
32	5 800	1 590	710	1	1.9	95	93	M 8 x 40
40	8 500	2 120	940	1	1.9	173	173	M10 x 50
52	11 700	5 830	2 560	1	1.9	374	365	M14 x 60

- 1) Housing bore tolerance: H7
- 2) Safety threads SPIRALOCK
- 3) Cw basic load for 100 km
- 4) Guide roller with washers DIN134 without screw DIN7984 or DIN912
- 5) FR/R 22, 32, 40 AS and AZ are available in stainless steel (NX)

- 6) AZ: minimum length of the thread engaged  
 steel = 1 x d  
 cast iron = 1.25 x d  
 aluminium = 2 x d  
 AS screws length: min = d+o+s; max = m+4+o+s

NBR seals RS type  
 Pressure angle  $\alpha$  for load calculation: 40°



## Floating guide rollers FRL..EU

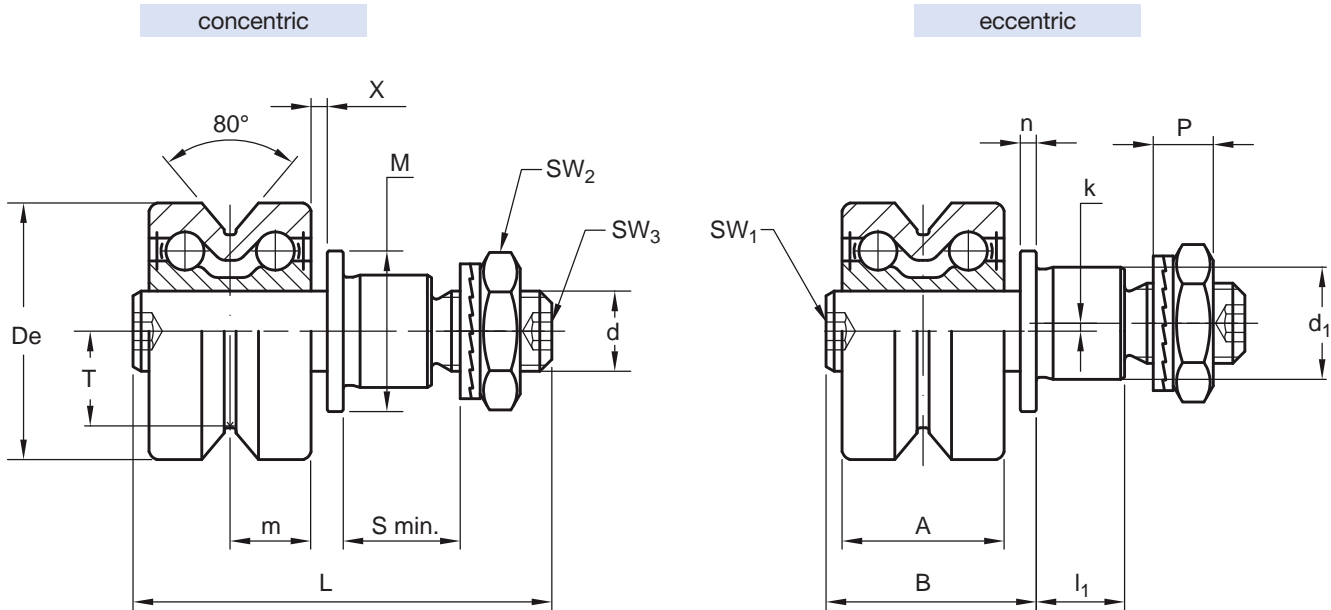
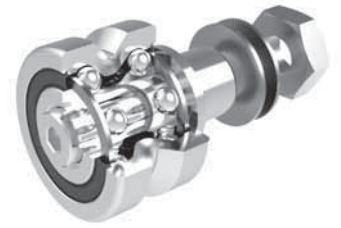

The race ways are slightly convex

Type		Dimensions (mm)																	
concentric	eccentric	De	d <sub>1</sub> <sup>1)</sup>	d	T	m	S <sub>min</sub>	P	L	A	B	l <sub>1</sub>	M	n	X	SW <sub>1</sub>	SW <sub>2</sub>	SW <sub>3</sub>	k
<b>FRL 22 EU</b> <sup>5)</sup>	<b>FRLR 22 EU</b> <sup>5)</sup>	22	9	M6 x 1.0	7.7	7.5	9	6.5	39.3	15.0	20.5	8.0	14.0	1.5	2	4	10	3	0.8
<b>FRL 32 EU</b> <sup>5)</sup>	<b>FRLR 32 EU</b> <sup>5)</sup>	32	14	M10 x 1.25	11.8	10.1	12	8.5	52.2	20.2	26.2	11.0	20.0	2	2	4	17	4	1.0
<b>FRL 40 EU</b> <sup>5)</sup>	<b>FRLR 40 EU</b> <sup>5)</sup>	40	16	M12 x 1.5	14.6	12.5	12	10.4	61.4	25.0	32.4	11.0	22.0	2.4	2.5	5	19	5	1.0
<b>FRL 52 EU</b>	<b>FRLR 52 EU</b>	52	21	M16 x 1.5	19.1	16.0	15	11.4	74	32.0	41.0	14.0	28.0	3	3	6	24	6	1.5
<b>FRL 62 EU</b>	<b>FRLR 62 EU</b>	62	27	M20 x 1.5	22.1	16.8	18.5	12.4	83.6	33.6	42.6	17.5	35.0	3	3	8	30	8	2.0

Type		Dynamic load (N)	Limit load (N)	Limit load Inox version (N) NX	Torque wrench setting <sup>2)</sup> (Nm)	Weight (g)
		C <sub>w</sub> <sup>4)</sup>	radial F <sub>r</sub>	radial F <sub>r</sub>		
<b>FRL 22 EU</b>	<b>FRLR 22 EU</b>	2900	1050	980	3	46
<b>FRL 32 EU</b>	<b>FRLR 32 EU</b>	5800	1700	1550	20	127
<b>FRL 40 EU</b>	<b>FRLR 40 EU</b>	8500	3000	2750	26	233
<b>FRL 52 EU</b>	<b>FRLR 52 EU</b>	11700	7600	6850	64	520
<b>FRL 62 EU</b>	<b>FRLR 62 EU</b>	13900	11000	10300	120	776

1) Housing bore tolerance: H7

2) The torque wrench settings are given for non-lubricated threads; for lubricated threads multiply figure by 0.8

3) Weight without fittings

4) C<sub>w</sub> = Basic load for 100 Km

5) Dimensions for stainless steel (NX) version

Standard seals: material NBR, RS type

Guide rollers include self-locking washers and hexagonal nut (DIN 439B)

Pressure angle  $\alpha$  for load calculation: 40°

# Base-Line

## Carriage T4FR

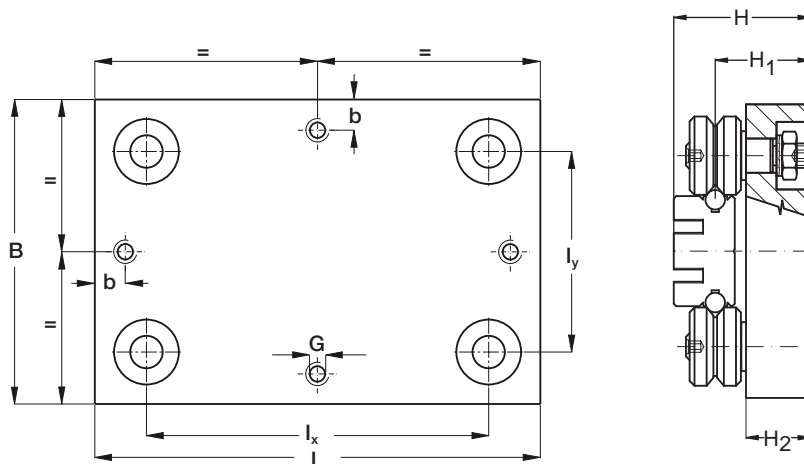

Type	Dimensions (mm)									Weight (kg)	Suggested combinations
	L	B	$l_x$	$l_y$	H	$H_1$	$H_2$	G	b		
<b>T4FR 22 90</b>	90	90	59	58.7	42.4	28.4	19	M6	15	0.6	<b>FWS 22</b>
<b>T4FR 22 150</b>	150	90	119	58.7	42.4	28.4	19	M60	15	0.9	<b>FWS 22</b>
<b>T4FR 32 120</b>	120	120	78	78	58.6	41.6	29	M8	15	1.5	<b>FWS 32</b>
<b>T4FR 32 180</b>	180	120	138	78	58.6	41.6	29	M80	15	2.1	<b>FWS 32</b>
<b>T4FR 40 150</b>	150	150	99	98.8	63.5	44.5	29	M8	15	2.6	<b>FWS 40</b>
<b>T4FR 40 220</b>	220	150	169	98.8	63.5	44.5	29	M80	15	3.4	<b>FWS 40</b>
<b>T4FR 52 190</b>	190	190	123	123	82.8	58.8	39	M10	20	5.4	<b>FWS 52</b>
<b>T4FR 52 260</b>	260	190	203	123	82.8	58.8	39	M10	20	6.8	<b>FWS 52</b>

# Base-Line

## Guide Rollers combination

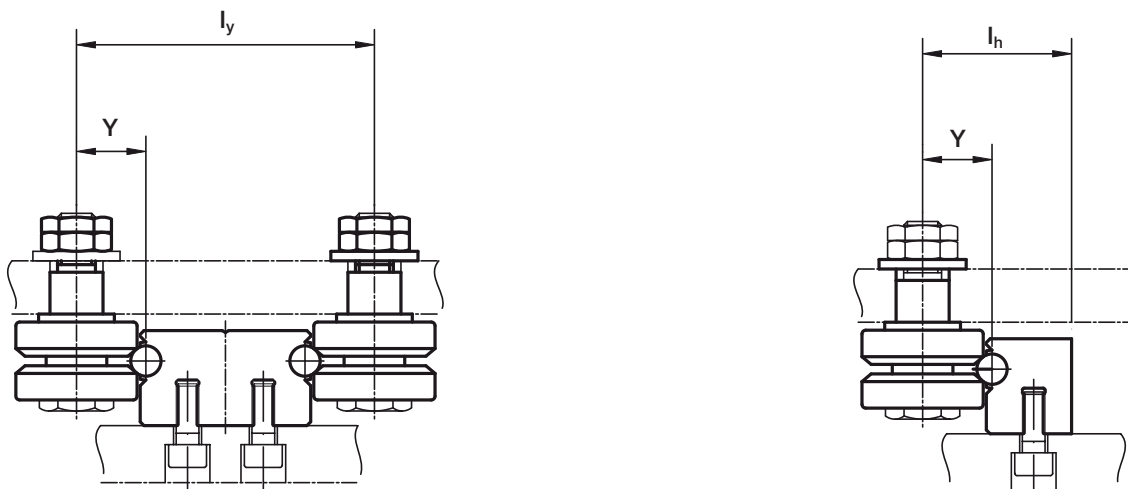

Type		Roller type FR/FRR..EU, FR/FRR..EU AS, FR/FRR..EU AZ, FRLK, FRLR, FRL		
		Y	l <sub>y</sub>	l <sub>h</sub>
FWS 22	FWH 22	12.4	58.8	29.4
FWS 32	FWH 32	18	78	39
FWS 40	FWH 40	22.4	98.8	49.4
FWS 52	FWH 52	28.4	122.8	61.4

## Mounting Examples

Glue dispensing machine

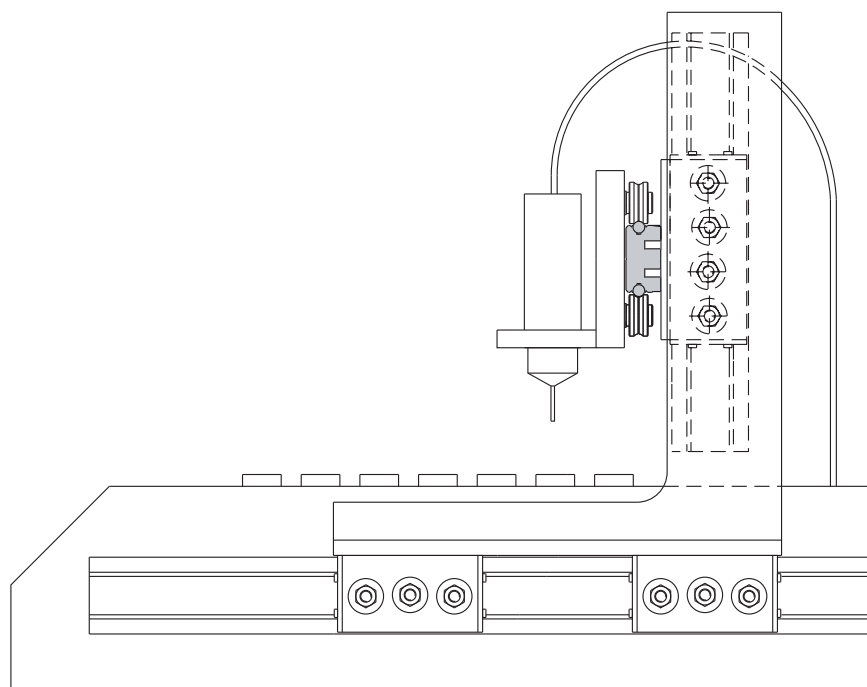

# Flexi-Line 645

## FWN System

---

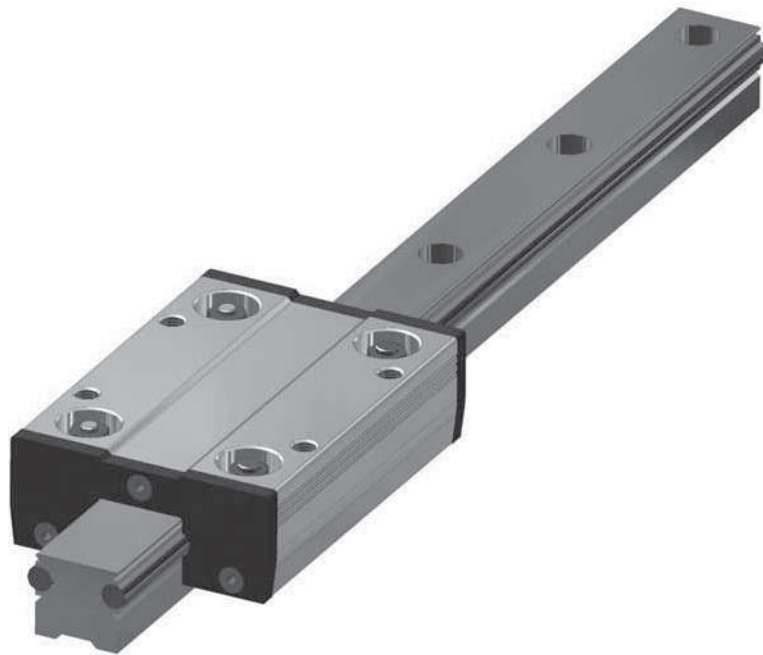

# Flexi-Line 645

## System Flexi-Line 645

Aluminium guide rails FWN as well as carriages TA4 and TB4 are the components of this line.

In addition to the standard dimensions that are ISO 645 compatible, the guide system can be adapted to customers' requirements.

Bore holes and threads on the guide rails can be made in any distance required, the carriages may have over-lengths and a special hole pattern and all this is also available as corrosion resistance type "NX".

Compared to linear guides made of steel these guide rails and carriages weigh up to 45% less and stand out due to their excellent running performance which minimises the driving power and reduces significantly the cost for motors and controls.

With eccentric bolts the guide rollers of the carriages are kept free from play. However the user also has the possibility to change the settings, for example in case of vibrations, and to apply an individual preload on the guide system. On both sides of the carriages can be mounted end plates with oil-soaked felt seals to ensure low-wear operation.

The following graph applies to the loads indicated in the tables:

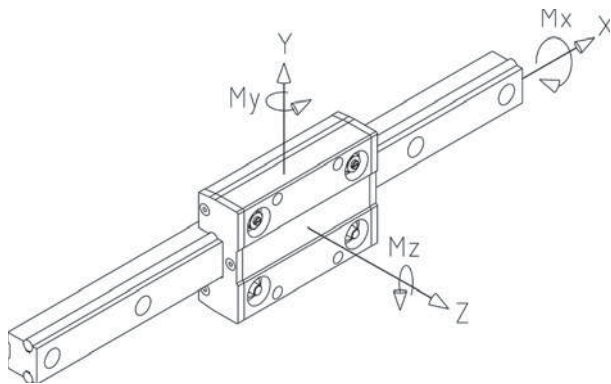

### MAXIMUM LOAD ON INDIVIDUAL CARRIAGES

The table below shows the maximum load that can be applied to an individual carriage.

Carriage	Fy (N)	Fz (N)	Mx (Nm)	My (Nm)	Mz (Nm)
TA4GLA17.06 TB4GLA17.06	600	400	5	15	20
TA4GLA19.06 TB4GLA19.06	1 700	960	19	33	70

### DYNAMIC LOAD OF THE INDIVIDUAL CARRIAGE

The table below shows the load corresponding to the nominal working life of 100 km.

The nominal working life of the carriage can be determined by the standard bearing formula.

$$L_{10} = (C_i/P_i)^3 \times 100 \text{ km}$$

$C_i$  is the carrying capacity in a specific direction and  $P_i$  is the load applied in the same direction.

Carriage	Cy (N)	Cz (N)	CMx (Nm)	CMy (Nm)	CMz (Nm)
TA4GLA17.06 TB4GLA17.06	2 596	1 445	13	46	84
TA4GLA19.06 TB4GLA19.06	4 920	2 700	30	100	180

Important:

- Values are calculated on the basis of lubricated rails
- For combined loads please proceed as indicated in the calculation examples at the beginning of the catalogue. In case of questions our application engineers will be pleased to assist you.

# Flexi-Line 645

## Guide rails FWN Dimensions according to DIN 645

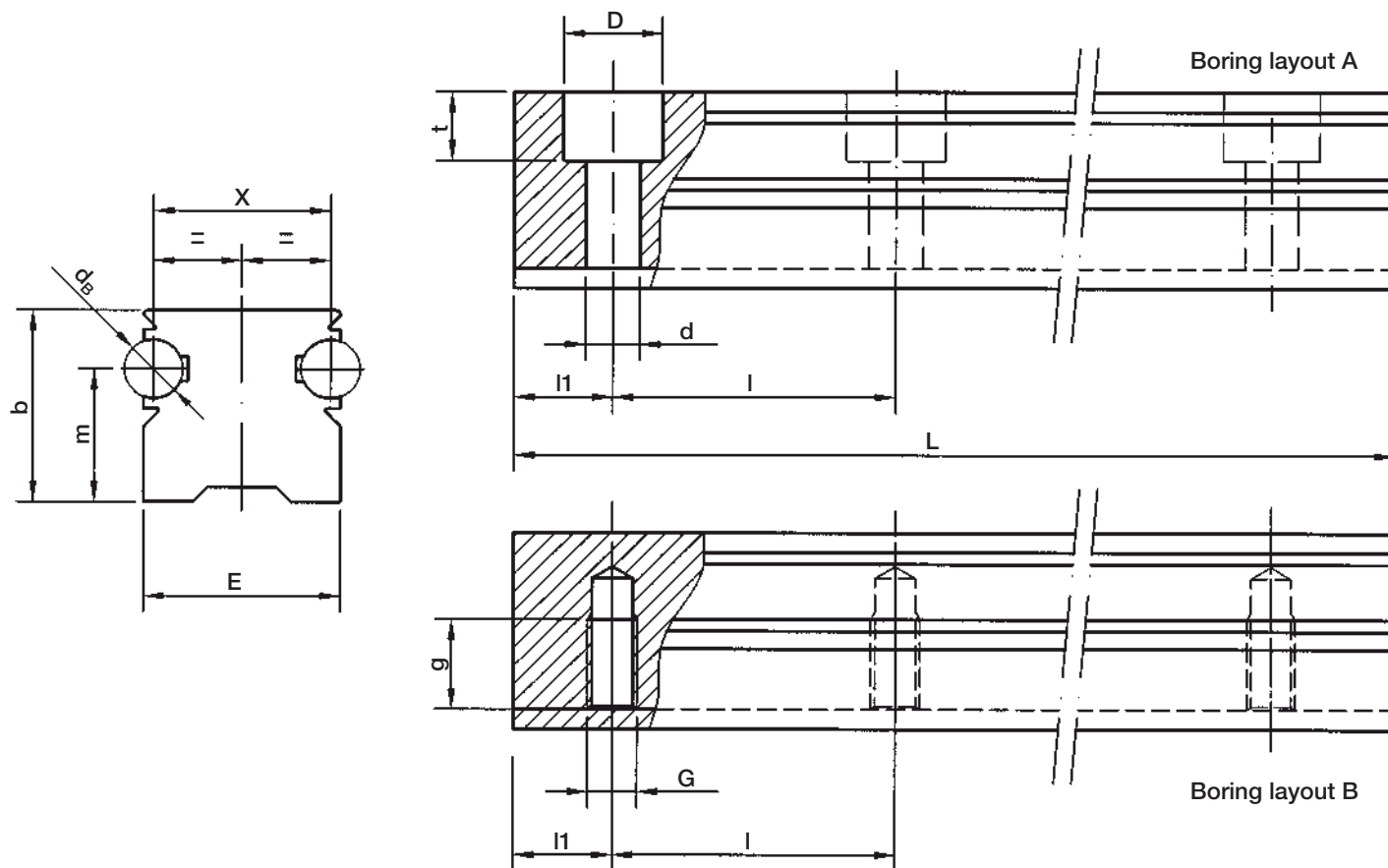

Type	Dimensions (mm)												Weight (kg/m)
	$d_B$	E	X	D	d	G	g	m	t	b	$l_1$	l	
<b>FWN 20</b>	6	20	18	10	5.5	M6	12	13.5	7	19.5	30	60	1.3
<b>FWN 25</b>	6	23	21	11	6.6	M6	12	18	8.5	25.5	30	60	1.8

Max length of single guide element L=5 800 mm (1)

1) Longer rails are supplied in sections with ground butt-joints

### Hole layout

- holes according to DIN (**A** or **B**)
- finishes to drawing (**NZ**)
- without holes (**NF**)

### Optional features

- ground one end (**R**)
- ground both ends (**RR**)
- stainless steel shafts (**NX**)

Example of standard designation: **FWN20/1000 A**

See page 17 for standard codification

# Flexi-Line 645

## Carriage TA4 Dimensions according to DIN 645

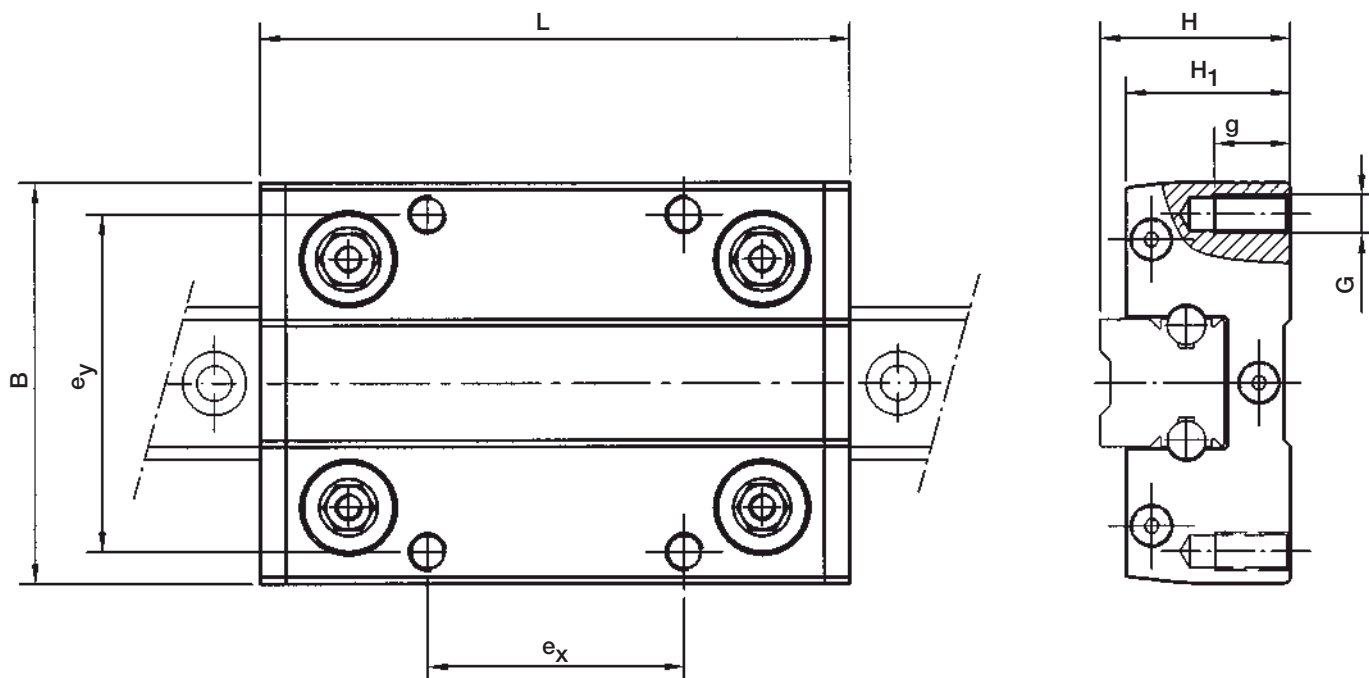

Type	Dimensions (mm)								Weight (kg)	Suggested combinations
	B	G	H	H <sub>1</sub>	L	e <sub>x</sub>	e <sub>y</sub>	g		
TA4GLA 17.06	63	M6	30	26	92	40	53	12	0.3	<b>FWN 20</b>
TA4GLA 19.06	70	M8	36	31	104	45	57	16	0.4	<b>FWN 25</b>

Longer carriages on request

### Max load on a single carriage

Carriage	F <sub>y</sub> (N)	F <sub>z</sub> (N)	M <sub>x</sub> (Nm)	M <sub>y</sub> (Nm)	M <sub>z</sub> (Nm)
TA4GLA 17.06	600	400	5	15	20
TA4GLA 19.06	1 700	960	19	33	70

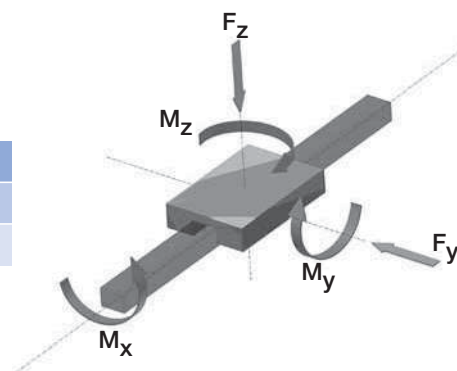

#### Optional features

- available with stainless steel guide rollers (**NX**)
- available with felts for lubrication (**UU**)



# Flexi-Line 645

## Carriage TB4 Dimensions according to DIN 645

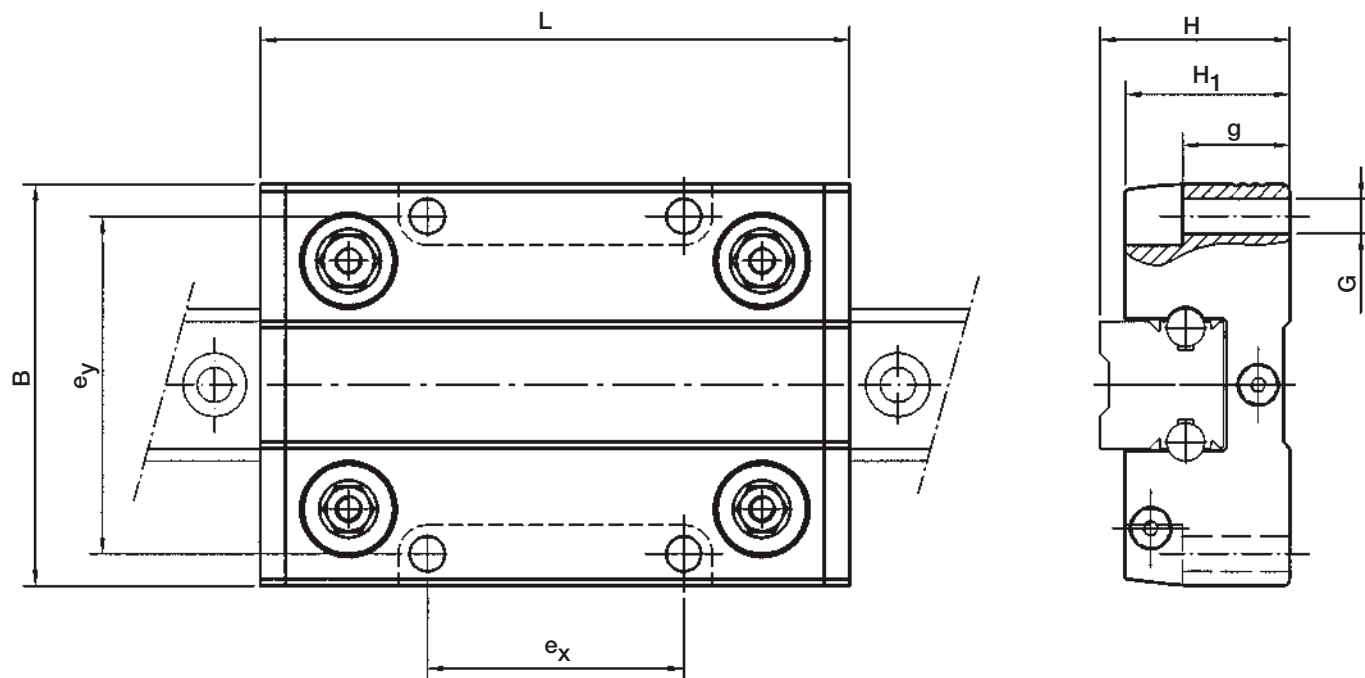

Type	Dimensions (mm)								Weight (kg)	Suggested combinations
	B	G	H	H <sub>1</sub>	L	e <sub>x</sub>	e <sub>y</sub>	g		
<b>TB4GLA 17.06</b>	63	5.5	30	26	92	40	53	17	0.25	<b>FWN 20</b>
<b>TB4GLA 19.06</b>	70	6.6	36	31	104	45	57	23.5	0.35	<b>FWN 25</b>

Longer carriages on request

### Max load on a single carriage

Carriage	F <sub>y</sub> (N)	F <sub>z</sub> (N)	M <sub>x</sub> (Nm)	M <sub>y</sub> (Nm)	M <sub>z</sub> (Nm)
<b>TB4GLA 17.06</b>	600	400	5	15	20
<b>TB4GLA 19.06</b>	1 700	960	19	33	70

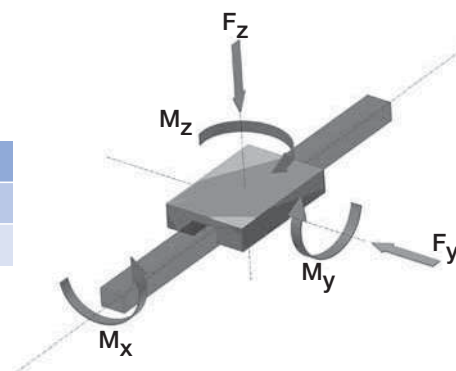

#### Optional features

- available with stainless steel guide rollers (**NX**)
- available with felts for lubrication (**UU**)



# Flexi-Line 645

## Mounting examples

Medical equipment  
Flexi-Line

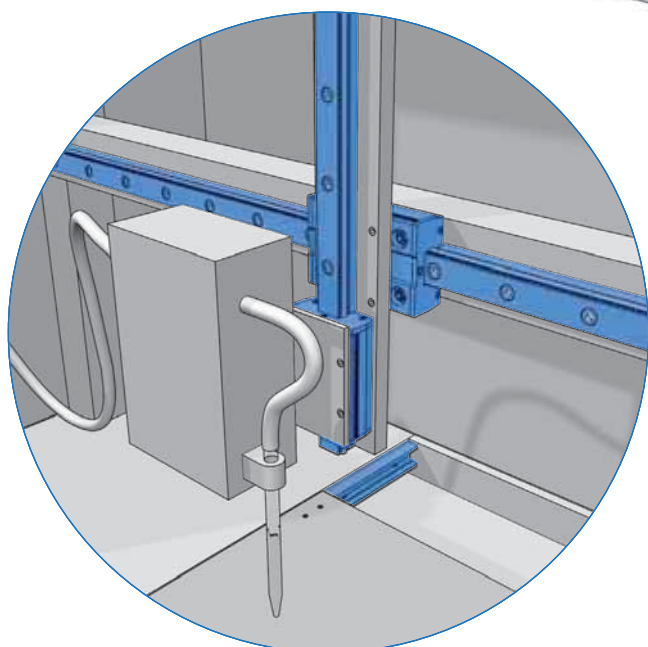
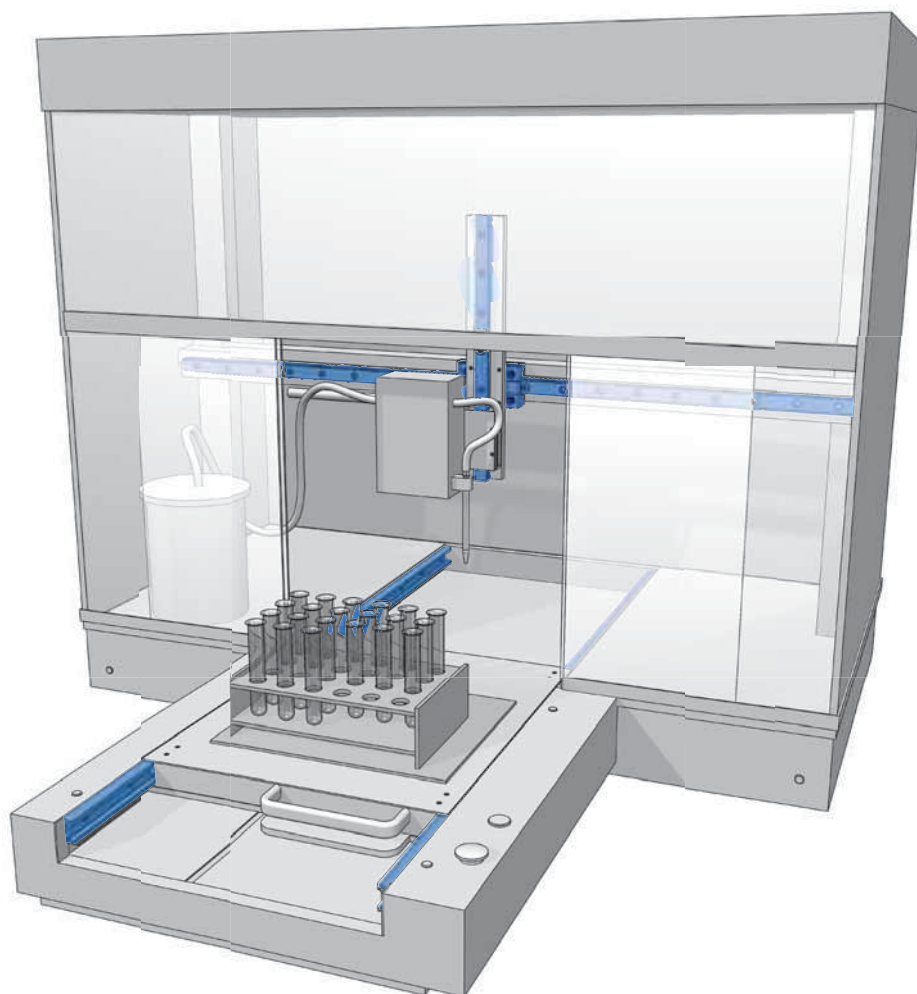

# U-Line

## LM, LML System

---

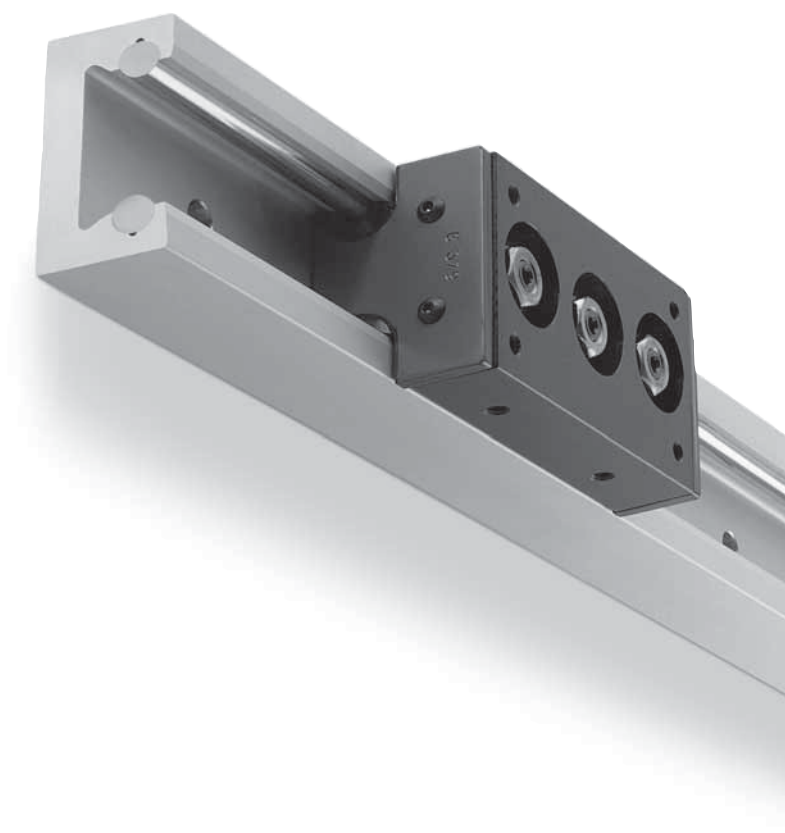

## LM system

LM system is based on rail, guide rollers and carriages to provide a complete guiding system.

Guide rails and rollers can be used as single elements. In most cases the application is based on standard carriages and cursors.

Referring to the axis system below, the load capacities are tabulated as follows:

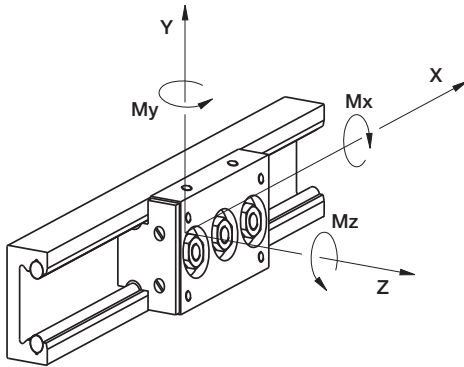

### MAX LOAD ON SINGLE CARRIAGE

The following table shows the maximum load that can be applied on a single carriage.

Guide	Carriage	Fy N	Fz N	Mx Nm	My Nm	Mz Nm
LM 30	C3 RCL 17 06 065	1000*	330	3,5	5,8	10
	C4 RCL 17 06 085	1000	660	7	11	20
LM 40	C3 RCL 24 06 085	1810*	520	7,6	15	26
	C4 RCL 24 06 114	1810	1040	15	25	52
LM 65	C3 RCL 35 10 115	4160*	1200	26	45	78
	C4 RCL 35 10 152	4160	2400	50	75	155
LM 90	C4 RCL 35 10 180	4160	2400	75	95	200
LM 120	T4 RCL 35 10 150	4160	2400	110	120	200
	T4 RCL 35 10 220	4160	2400	110	200	350
	T4 RCP 42 10 150	5250	3030	140	150	260
	T4 RCP 42 10 220	5250	3030	140	250	440
LM 180	T4 PFV 43 22 180	6300	3120	185	200	400
	T4 PFV 43 22 280	6300	3120	185	350	715

\* Fy directed to load the two concentric guide rollers

The maximum load is based on the guide roller data (stud and bearing strength) and on maximum contact pressure between rail and roller of 1250 N/mm<sup>2</sup>. Loading is considered to be acting in a single plane or axis only.

### BASIC DYNAMIC LOAD OF SINGLE CARRIAGE

The following table shows the nominal load that corresponds to a nominal life of the bearing at 100 km.

The nominal carriage life can be estimated from the standard bearing formula.

$$L_{10} = (C_i/P_i)^3 \times 100 \text{ km}$$

C<sub>i</sub> and P<sub>i</sub> are the basic capacity and load applied for a specific direction.

Guide	Carriage	Cy N	Cz N	CMx Nm	CMy Nm	CMz Nm
LM 30	C3 RCL 17 06 065	3000*	830	9	16	30
	C4 RCL 17 06 085	3000	1670	18	26	60
LM 40	C3 RCL 24 06 085	8400*	2340	34	67	122
	C4 RCL 24 06 114	8400	4670	68	110	244
LM 65	C3 RCL 35 10 115	15800*	4050	86	152	296
	C4 RCL 35 10 152	15800	8110	172	250	593
LM 90	C4 RCL 35 10 180	15800	8110	263	325	770
LM 120	T4 RCL 35 10 150	15800	8110	370	400	780
	T4 RCL 35 10 220	15800	8110	370	685	1335
	T4 RCP 42 10 150	24000	14130	650	700	1190
	T4 RCP 42 10 220	24000	14130	650	1195	2030
LM 180	T4 PFV 43 22 180	15190	5300	320	335	965
	T4 PFV 43 22 280	15190	5300	320	600	1725

\* Fy directed to load the two concentric guide rollers

### Calculation example: four carriages C3RCL 35 10 115 platform

The common configuration is shown in the here following sketch:

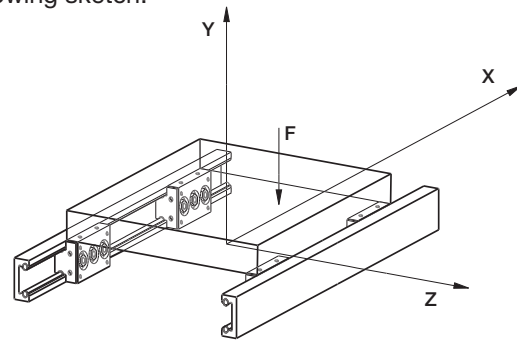

The platform moves along the two guide rails and has a load of "F" acting at 100 mm and 50 mm from the carriage centre.

Data: guide LM 65 and carriages C3RCL3510115

$$I_x = 400 \text{ mm} \quad I_z = 300 \text{ mm}$$

$$F = 6.000 \text{ N} \quad X_F = 100 \text{ mm} \quad Z_F = 50 \text{ mm}$$

In this configuration the load on the most heavily loaded carriage is P<sub>y</sub> and can be calculated using the following formula:

$$P = \frac{F}{4} + \frac{F \cdot X_F}{2 \cdot I_x} + \frac{F \cdot Z_F}{2 \cdot I_z} = 2750 \text{ N}$$

The load F<sub>y</sub> shown in the "max loads" table is 4.160N (carriages mounted with eccentric roller on top), so the system is validated against breakage.

To estimate the system life we proceed as follows: from the nominal life table C<sub>y</sub> = 15.800 N

$$L_{10} = (15.800/2.750)^3 \times 100 = 18.900 \text{ km}$$

Important note: to reach this value it is important to lubricate the rail, otherwise fretting corrosion between rail and roller can reduce the expected life.

## Auto-aligning system

### Systems

Auto-aligning systems are assembled with guide rollers RAL type on LM system carriages tables.

The guide rollers RAL type allows axial displacement of the roller on the pin. An "O" ring retains the roller in position during the mounting.

Auto-aligning systems compensate for opposite rail misalignment errors. They are useful for mounting inaccurately aligned structures or those structures subject to flexure.

### C3RAL C4RAL T4RAL

Is used to compensate for  $D_x$  misalignment between opposite rails. The table or carriage with all guide rollers RAL/RALR type can move towards or away from the rail. Type RAL provides radial support only. Axial load, transverse to the direction of travel, is reacted by carriage type RCL on the opposite rail.

### C3RYL C4RYL T4RYL

Rail misalignment  $D_y$  requires the ability for both carriages to rotate. The table or carriage RYL type, with guide rollers RCL/RCP in contact with a steel shaft of the LM rail and guide rollers RALR type in contact with the opposite shaft, allows carriage rotation ensuring at the same time the transverse direction control.

The maximum  $D_y$  value is dependent on the distance between the rails and the tabulated maximum angle ' $\alpha$ ' for that carriage.

Note: RYL carriage axial load capability is lower than the same size RCL/RCP carriage.

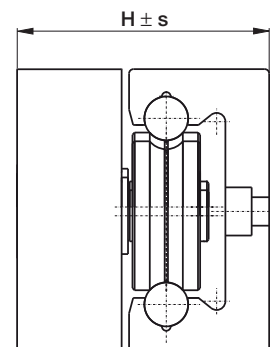
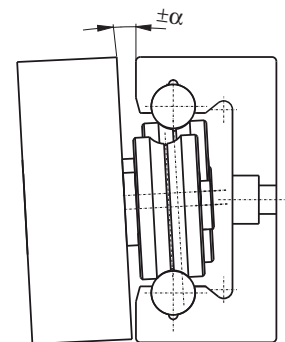
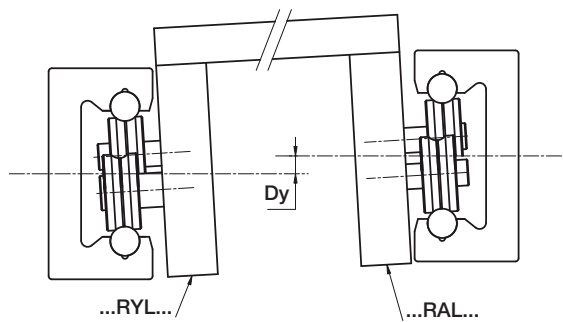
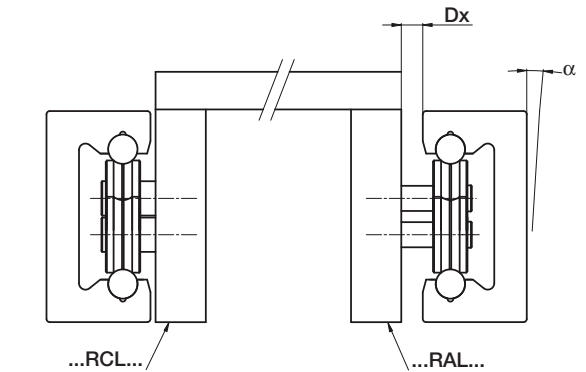
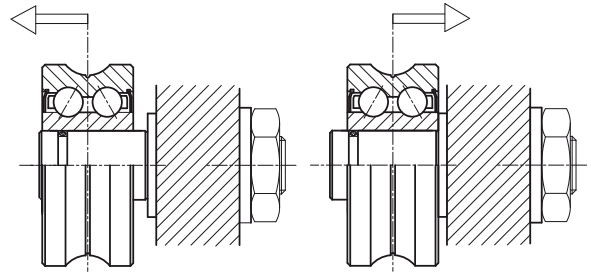

### Max transverse moving allowed by auto-aligning tables and carriages

Carriage code (1)		$\alpha$ max (°)	S max (mm)	H nominal (mm)	Rail
C3RAL 17 06 065	C4RAL 17 06 085	1	0.8	27.5	LM 30
C3RYL 17 06 065	C4RYL 17 06 085	1	-		
C3RAL 24 06 085	C4RAL 24 06 114	1	1	35.7	LM 40
C3RYL 24 06 085	C4RYL 24 06 114	1	-		
C3RAL 35 10 115	C4RAL 35 10 152	1	1	58	LM 65
C3RYL 35 10 115	C4RYL 35 10 152	1	-		
-	C4RAL 35 10 180	1	1	60.5	LM 90
-	C4RYL 35 10 180	1	-		
T4RAL 35 10 150	T4RAL 35 10 220	0.3	1	58.5	LM 120
T4RYL 35 10 150	T4RYL 35 10 220	0.3	-		
T4RAL 42 10 150	T4RAL 42 10 220	0.75	1.5	65.5	
T4RYL 42 10 150	T4RYL 42 10 220	0.75	-		

1) See light load systems Nadella catalogue for table and carriage dimensions.

2) Variations of dimension H exceeding  $\pm s$  can compromise bearing axial moving and decrease the roller limit load, Fr.

# U-Line

## Guide rails LM



LM 30

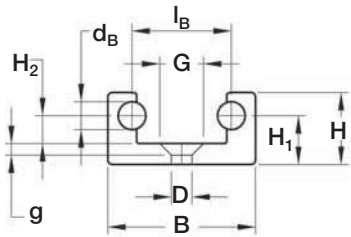

LM 90

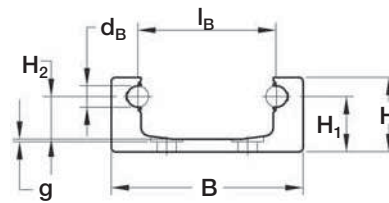

LM 40

LM 65

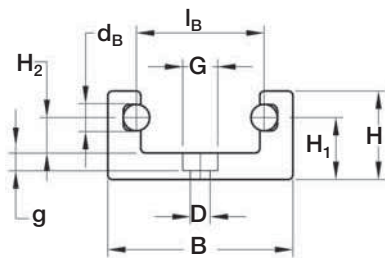

LM 120

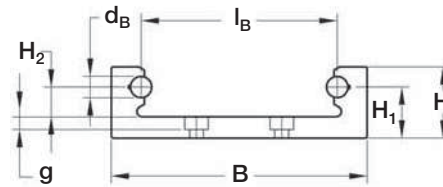

LM 180

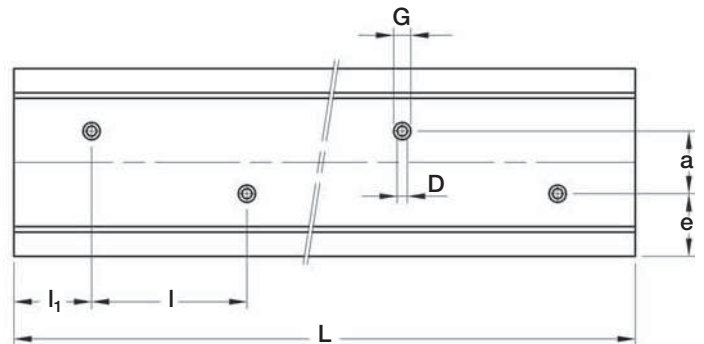
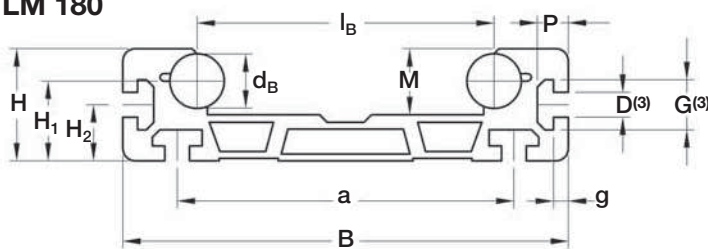

Type	Dimensions (mm)															Moments of inertia <sup>(2)</sup> (cm <sup>4</sup> )		Weight (kg/m)	L <sup>(1)</sup> max (mm)
	d <sub>B</sub>	l <sub>B</sub>	B	H	H <sub>1</sub>	H <sub>2</sub>	M	D	G	g	a	e	P	l	l <sub>1</sub>	J <sub>x</sub>	J <sub>y</sub>		
LM 30 <sup>(4)</sup>	6	21.5	32	15.5	10.5	6	11	4.5	9.5	2.5	-	16	-	80	40	0.5	3	1.1	6 000
LM 40 <sup>(4)</sup>	6	29	42	20	14	8	14	4.5	8	4	-	21	-	100	50	1.2	8.8	1.5	6 000
LM 65 <sup>(4)</sup>	10	42.5	65	32	23.5	13.5	22	6.5	11	6	-	32.5	-	100	50	8.8	54.9	4.1	6 000
LM 90 <sup>(4)</sup>	10	65	90	35	26	20	29	9	15	0.5	38	26	-	100	50	16.4	160.2	4.7	6 000
LM 120 <sup>(4)</sup>	10	92	120	33.5	24	14	23.5	6.5	11	6	40	40	-	100	50	14.8	311.6	6	6 000
LM 180	22	120	180	45	32	22.5	26.5	10 <sup>(3)</sup>	20.1 <sup>(3)</sup>	6	136	-	12.5	-	-	53.3	1 096.6	13.1	6 000

1) Longer rails are supplied in sections with ground butt joints and, on request, with pin connection

2) Inertia value based on equivalent aluminium yield 70000 N/mm<sup>2</sup>

3) Slot for nut DIN 508

4) available with stainless steel shafts (suffix **NX**)

### Hole layout

- holes according to catalogue (**SB**)
- finishes to drawing (**NZ**)
- without holes (**NF**)

### Optional features

- ground one end (**R**)
- ground both ends (**RR**)
- chromium plated shafts (**CH**)
- stainless steel shafts (**NX**)

Example of standard designation: **LM 40/1720 NF**

See page 17 for standard codification

## Guide rollers RCL, RCP, PFV

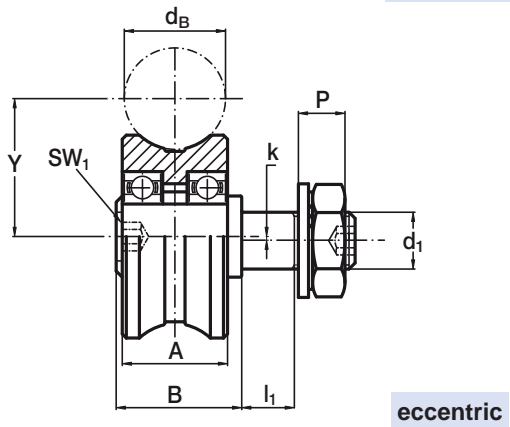
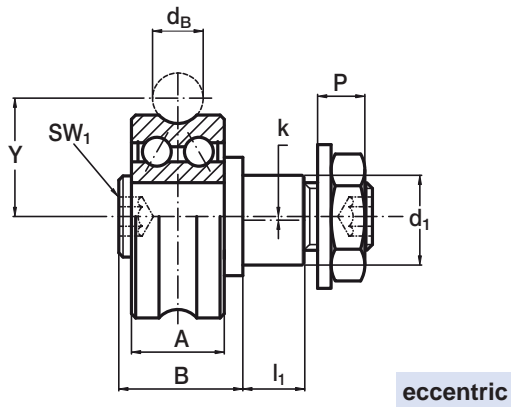
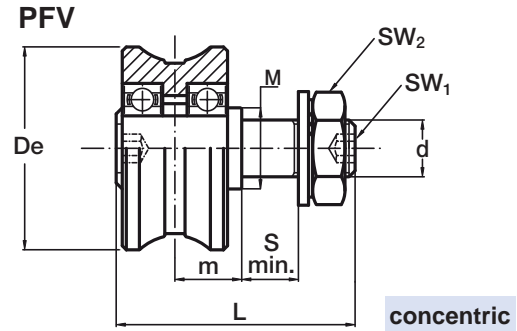
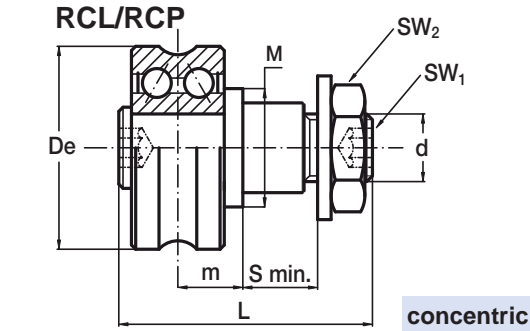

Type		Dimensions (mm)																Suggested combination	
concentric	eccentric	De	dB	d <sub>1</sub> <sup>(1)</sup> conc.	d <sub>1</sub> <sup>(1)</sup> ecc.	d	Y	m	S min.	P	L	A	B	l <sub>1</sub>	M	SW <sub>1</sub>	SW <sub>2</sub>		k
<b>RCL 17.06<sup>(3)</sup></b>	<b>RCLR 17.06<sup>(3)</sup></b>	17	6	5	6.5	M 5x0.8	10.5	6	6	3.7	21	7	11	5.2	9	2.5	8	0.25	<b>LM 30</b>
<b>RCL 24.06<sup>(3)</sup></b>	<b>RCLR 24.06<sup>(3)</sup></b>	24	6	8	11	M 8x1.25	14	7.7	7	5.6	28.2	11	14.7	6.5	14	4	13	0.5	<b>LM 40</b>
<b>RCL 35.10<sup>(3)</sup></b>	<b>RCLR 35.10<sup>(3)</sup></b>	35	10	10	10	M10x1.25	20.65	10.5	14	7	43	15.9	20.5	13	18	5	17	0.75	<b>LM 65</b>
<b>RCP 42.10</b>	<b>RCPR 42.10<sup>(3)</sup></b>	42	10	17	17	M12x1.25	24	12.5	12	9.5	50	19	24.5	11	25	6	19	0.75	<b>LM 120</b>
<b>PFV 43.22<sup>(3)</sup></b>	<b>PFVR 43.22<sup>(3)</sup></b>	43	22	12	12	M12x1.5	29	14	13	12.5	52	23	27	12	18	5	19	1	<b>LM 180</b>

Type		Dynamic load (N) C <sub>w</sub> <sup>(4)</sup>	Limit loads (N)		Life coefficients				Torque wrench <sup>(2)</sup> settings (Nm)	Weight (g)
			radial Fr	axial F <sub>a</sub>	Pa/Pr ≤ 0.37		Pa/Pr > 0.37			
					X	Y	X	Y		
<b>RCL 17.06</b>	<b>RCLR 17.06</b>	1 500	530	260	1	1.37	0.5	2.73	1.8	20
<b>RCL 24.06</b>	<b>RCLR 24.06</b>	4 200	1 600	830	1	1.37	0.5	2.73	8	40
<b>RCL 35.10</b>	<b>RCLR 35.10</b>	7 900	2 400	1 100	1	1.67	0.5	3.03	20	130
<b>RCP 42.10</b>	<b>RCPR 42.10</b>	12 000	4 300	1 160	1	1.17	0.5	2.53	24	185
<b>PFV 43.22</b>	<b>PFVR 43.22</b>	7 600	3 150	780	1	4	1	4	26	205

1) Housing bore tolerance: H7

2) The torque wrench settings are given for non-lubricated threads; for lubricated threads, multiply figure by 0.8

3) Available in stainless steel (suffix **NX**) with RS seals type

4) C<sub>w</sub> basic load for 100 km

5) The guide rollers are complete with self-locking washers and hexagonal nut (DIN 439B) for fitting

6) Pressure angle α for load calculation: 60°

7) Standard shields ZZ type for RCL and RCP; NBR seals type RS for PFV



concentric

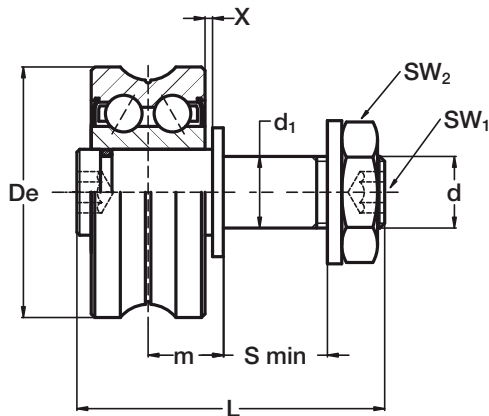

eccentric

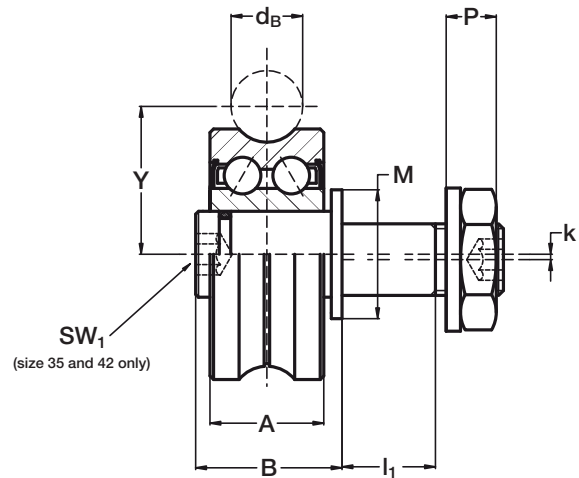

Type		Dimensions (mm)																		Suggested combination
concentric	eccentric	De	dB	d <sub>1</sub> <sup>(1)</sup> conc.	d <sub>1</sub> <sup>(1)</sup> ecc.	d	Y	m	S min.	P	L	A	B	X <sup>(5)</sup>	I <sub>1</sub>	M	SW <sub>1</sub>	SW <sub>2</sub>	k	
<b>RAL 17.06</b> <sup>(6)</sup>	<b>RALR 17.06</b> <sup>(6)</sup>	17	6	5	6.5	M 5x0.8	10.5	6	6	3.7	20.5	7	10.5	0.8	5.2	9	2.5	8	0.25	<b>LM 30</b>
<b>RAL 24.06</b> <sup>(6)</sup>	<b>RALR 24.06</b> <sup>(6)</sup>	24	6	8	11	M 8x1.25	14	7.7	7	5.6	27.5	11	14	1	6.5	14	4	13	0.5	<b>LM 40</b>
<b>RAL 35.10</b> <sup>(6)</sup>	<b>RALR 35.10</b> <sup>(6)</sup>	35	10	10	10	M10x1.25	20.65	10.5	14	7	43	15.9	20.5	1	13	18	5	17	0.75	<b>LM 65</b>
<b>RAL 42.10</b>	<b>RALR 42.10</b>	42	10	17	17	M12x1.25	24	12.5	12	9.5	49	19	23.5	1.5	11	25	6	19	0.75	<b>LM 120</b>

Type		Dynamic load (N)	Limit loads (N) <sup>(5)</sup>	Torque wrench <sup>(2)</sup> settings (Nm)	Weight (g)
		C <sub>w</sub> <sup>(3)</sup>	radial F <sub>r</sub>		
<b>RAL 17.06</b>	<b>RALR 17.06</b>	1 500	450	1.8	20
<b>RAL 24.06</b>	<b>RALR 24.06</b>	4 200	1 400	8	40
<b>RAL 35.10</b>	<b>RALR 35.10</b>	7 900	2 100	20	130
<b>RAL 42.10</b>	<b>RALR 42.10</b>	12 000	3 400	24	185

1) Housing bore tolerance: H7

2) The torque wrench settings are given for non-lubricated threads; for lubricated threads, multiply figure by 0.8

3) C<sub>w</sub> basic load for 100 km

4) The guide rollers are complete with self-locking washers and hexagonal nut for fitting

5) Dimension ± X is the max displacement from dimension m to ensure proper guide roller function and safety

6) Available in stainless steel (suffix **NX**) with **RS** seals type

7) Standard shields ZZ type

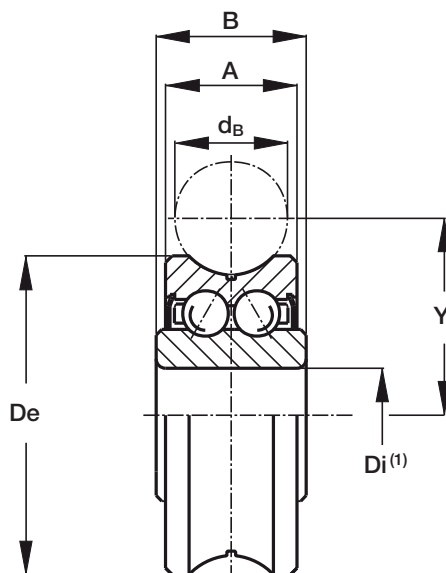

Type	Dimensions (mm)					
	De	dB	Di <sup>(1)</sup>	Y	A	B
GLA 17.06 <sup>(4)</sup>	17	6	5	10.5	7	8
GLA 24.06 <sup>(4)</sup>	24	6	8	14	11.9	11.9
GLA 35.10 <sup>(4)</sup>	35	10	12	20.65	15.9	15.9
GLA 35.12	35	12	12	21.75	15.9	15.9
GLA 42.10	42	10	12	24	19	19
GLA 47.10	47	10	15	26.65	19.9	19.9
GLA 52.16	52	16	20	31.5	20.6	22.6

Type	Dynamic load (N)	Limit loads (N)		Life coefficients				Weight (g)
				Pa/Pr ≤ 0.37		Pa/Pr > 0.37		
	C <sub>w</sub> <sup>(2)</sup>	radial C <sub>or</sub>	axial C <sub>oa</sub>	X	Y	X	Y	
GLA 17.06	1 500	840	350	1	1.37	0.5	2.73	10
GLA 24.06	4 200	2 300	1 000	1	1.37	0.5	2.73	20
GLA 35.10	7 900	5 100	1 500	1	1.67	0.5	3.03	80
GLA 35.12	7 800	5 000	1 400	1	2.47	0.5	3.83	80
GLA 42.10	12 000	7 100	2 100	1	1.17	0.5	2.53	100
GLA 47.10	15 400	9 200	3 300	1	0.97	0.5	2.33	170
GLA 52.16	19 300	10 500	4 000	1	2.17	0.5	3.53	230

1) Tolerance of Diameter Di: +0 / -0.008 mm

2) C<sub>w</sub> basic load for 100 km

3) Pressure angle α for load calculation: 60°

4) Available in stainless steel (suffix **NX**) with RS seals type

5) Standard shields ZZ type (GLA 52.16 with RS seals type)

## Carriage C3RCL, C3RAL, C3RYL

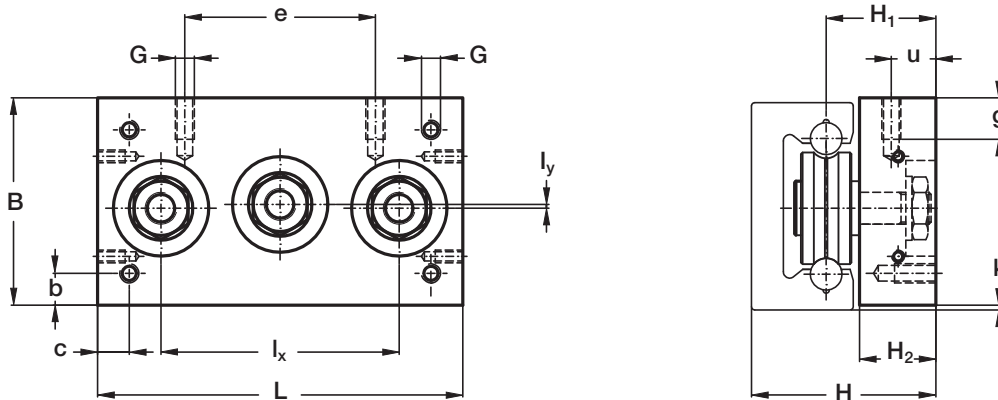

Type	Dimensions (mm)														Weight (kg)	Suggested combinations
	L	B	I <sub>x</sub>	I <sub>y</sub>	H	H <sub>1</sub>	H <sub>2</sub>	G	g	b	c	u	e	k		
<b>C3RCL 17 06 065</b>	65	32	40	0.5	27.5	17	11	M4	6	4	6	5.5	24	0.5	0.1	<b>LM 30</b>
<b>C3RCL 24 06 085</b>	85	42	58	1	35.7	21.7	14	M5	8	6	6	7	35	1	0.2	<b>LM 40</b>
<b>C3RCL 35 10 115</b>	115	65	75	1.2	58	34.5	24	M6	10	10	10	14	60	1.5	0.8	<b>LM 65</b>

- 1) Dimensions in the table are correct also for carriages C3 RAL, C3 RYL  
 2) Available with stainless steel guide rollers (suffix **NX**)

## Carriage C4RCL, C4RAL, C4RYL

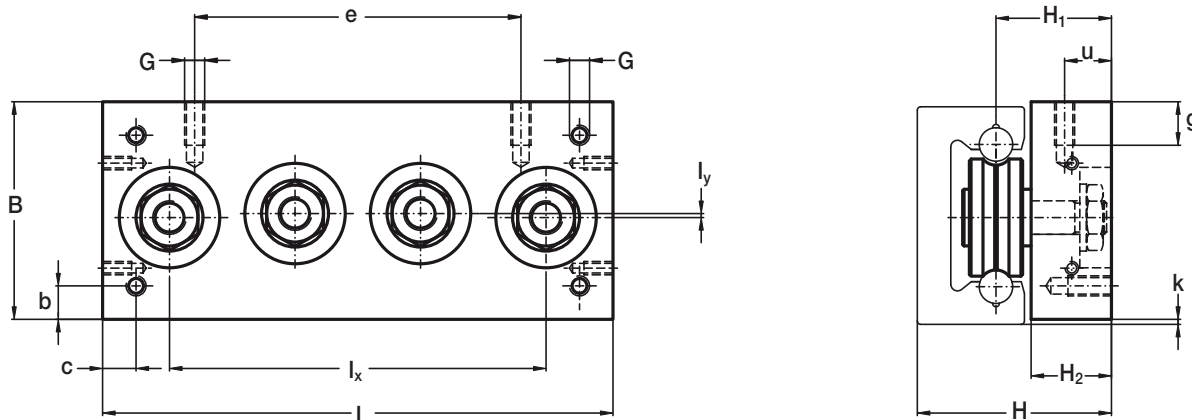

Type	Dimensions (mm)														Weight (kg)	Suggested combinations
	L	B	I <sub>x</sub>	I <sub>y</sub>	H	H <sub>1</sub>	H <sub>2</sub>	G	g	b	c	u	e	k		
<b>C4RCL 17 06 085</b>	85	32	60	0.5	27.5	17	11	M4	6	4	6	5.5	44	0.5	0.15	<b>LM 30</b>
<b>C4RCL 24 06 114</b>	114	42	87	1	35.7	21.7	14	M5	8	6	6	7	60	1	0.25	<b>LM 40</b>
<b>C4RCL 35 10 152</b>	152	65	112.5	1.2	58	34.5	24	M6	10	10	10	14	90	1.5	1	<b>LM 65</b>
<b>C4RCL 35 10 180</b>	180	90	135	23.7	60.5	34.5	24	M6	10	10	10	14	120	2	1.5	<b>LM 90</b>

- 1) Dimensions in the table are correct also for carriages C4 RAL and C4 RYL  
 2) Available with stainless steel guide rollers (suffix **NX**)

# U-Line

## Carriage T4RCL, T4RCP, T4PFV, T4RAL, T4RYL



T4RCL  
T4RCP

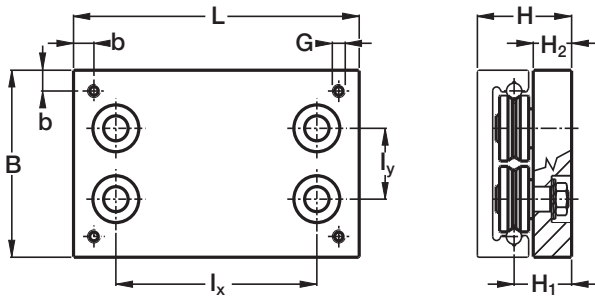

T4PFV

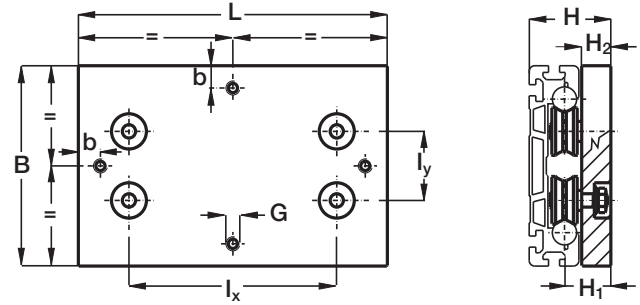

Type	Dimensions (mm)									Weight (kg)	Recommended pairing
	L	B	I <sub>x</sub>	I <sub>y</sub>	H	H <sub>1</sub>	H <sub>2</sub>	G	b		
T4RCL 35 10 150	150	120	99	50.7	58.5	34.5	24	M8	10	1.6	LM 120
T4RCL 35 10 220	220	120	169	50.7	58.5	34.5	24	M8	10	2.2	LM 120
T4RCP 42 10 150	150	120	99	44	65.5	41.5	29	M8	15	2	LM 120
T4RCP 42 10 220	220	120	169	44	65.5	41.5	29	M8	15	2.7	LM 120
T4PFV 43 22 180	180	180	127	62	74	42	28	M10	20	3.1	LM 180
T4PFV 43 22 280	280	180	227	62	74	42	28	M10	20	4.5	LM 180

1) Dimensions valid also for T4RAL and T4RYL

## Lubricator LUBM

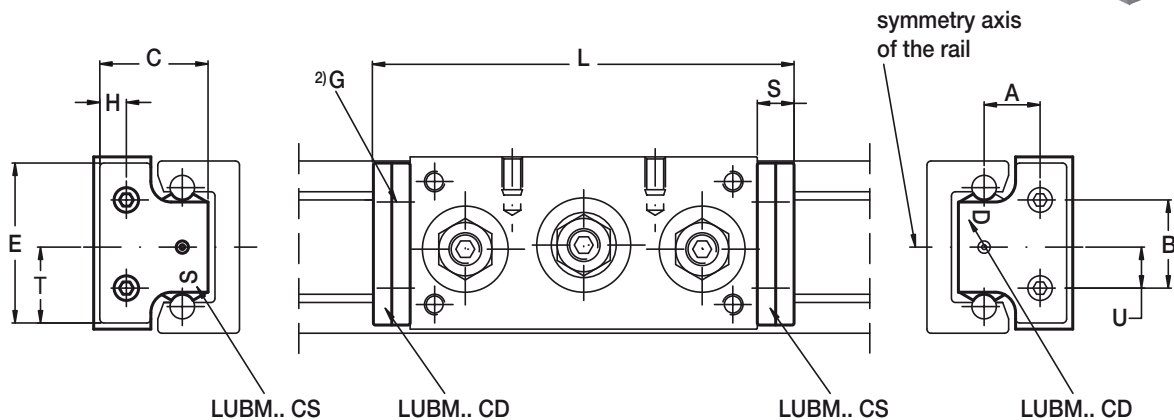
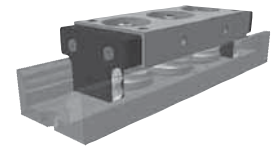

Type	Dimensions (mm)										Suggested combinations with the rails	
	A	B	U	E	T	H	C	G	S	L		
LUBM 030	9.5	16	8	30	15	6.5	20.5	M2.5	9	83	103	LM 30
LUBM 040 CD/CS	13.7	21.5	10	40	19	7	27	M3	9	103	132	LM 40
LUBM 065 CD/CS	20.5	30	15	63	30	13	44.5	M4	9	133	170	LM 65

1) The lubricator is supplied with the felt already lubricated. The lubricant has a mineral oil base - 2) One lubricator for packaging. Countersunk head screws for the mounting are already in the packaging - 3)The lubricator can be mounted on carriages RCL, RAL and RYL - (4) Optional felt without lubricant (D)

## System LML

### Application

Aluminium guide rails LML as well as RCL guide rollers with a plastic-coated outer ring are the components of this line.

LML can be used whenever extremely compact dimensions, simple linear motion and an economic solution are required.

LML system is suitable for manual and low precision movements, for safety doors, for the adjustment of cameras and sensors and many other products.

Applications can be found amongst others in mechanical engineering, medical and food engineering or object monitoring.

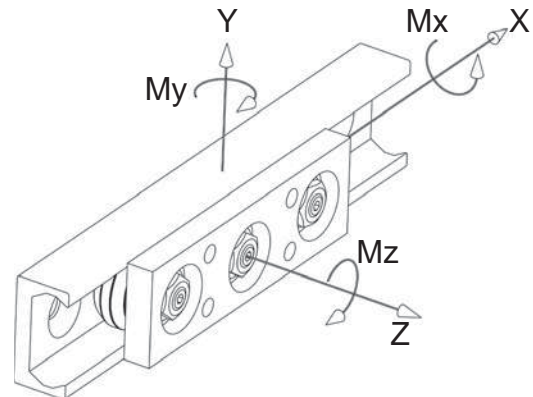

### Materials, surfaces, running characteristics

The guide rail, made of extruded aluminium, has a hard anodised surface. This grey-coloured protective coating ensures a significant protection against wear and corrosion. In addition, it has good tribological characteristics.

The guide rollers are made of corrosion-resistant bearing steel and their outer rings are coated with a special polyamide material.

This material combination contributes to a further improvement of the already known good running characteristics of Nadella roller guides and makes possible an absolutely low-noise linear motion without any stick-slip. In contrast to steel to steel combinations, the plastic coating of the guide rollers is slightly flexible and allows higher production tolerances and thus a cost-efficient production.

### Load rating and working life

The carrying capacity of the system is determined by the surface pressure between the plastic coating and the aluminium guide rail.

The working life is not calculated.

The following graph applies to the loads indicated in the tables:

### MAXIMUM LOAD ON INDIVIDUAL CARRIAGES

The table below shows the maximum static load that can be applied to an individual carriage for up to 100 hours without leading to permanent deformation of the outer rings. For short stress (<2s) and under dynamic load the values can be doubled.

Carriage	Fy (N)	Fz (N)	Mx (Ncm)	My (Ncm)	Mz (Ncm)
C3RCL 16 NX	150*	30	12.5	60	150
C4RCL 16 NX	150	60	25	95	300

\* Fy with effect on the two concentric rollers.

### Option sliding guide

For mostly static applications such as adjusting devices or for non-critical linear movements a suitable polyamide slide with incorporated lubricant is available. Please contact our application engineers.



# U-Line

## Guide Rails LML

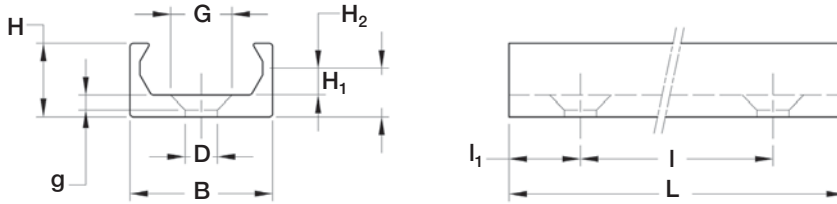

### Hole layout

- holes according to catalogue (SB)
- holes according to drawing (NZ)
- without holes (NF)

Type	Dimensions (mm)										Moments of inertia <sup>(1)</sup> (cm <sup>4</sup> )		Weight (kg/m)	L <sub>max</sub> (mm)
	B	H	H1	H2	D	G	g	l	l1	Jx	Jy			
LML 20	20	10.3	6.8	3.8	4.5	9.5	2.5	80	40	0.068	0.427	0.235	2800	

1) Inertia value based on E module for aluminium 70 000 N/mm<sup>2</sup>. Surface hard anodised

## Carriage C3RCL 16 NX

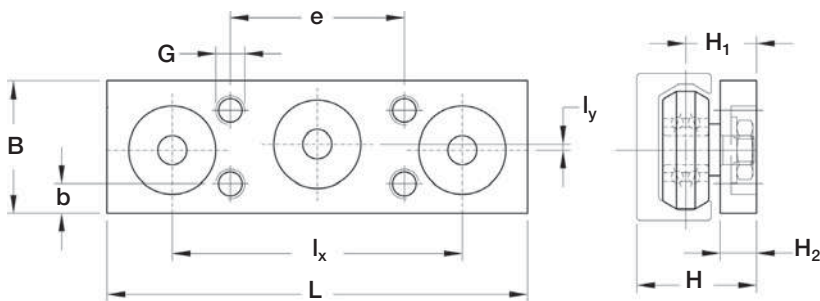

## Carriage C4RCL 16 NX

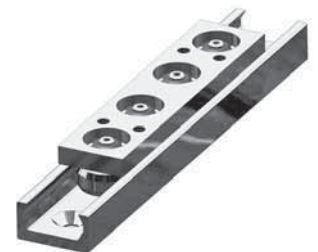
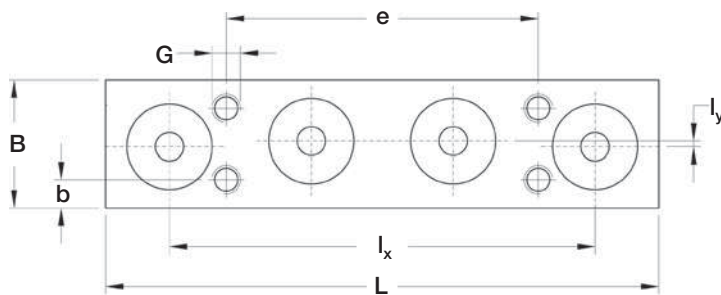

Type	Dimensions (mm)											Weight (g)
	L	B	lx	ly	H	H1	H2	G	b	e		
C3RCL 16 NX	58	18	40	0.8	16.5	9.75	5	M4	4	24	33	
C4RCL 16 NX	78	18	60	0.8	16.5	9.75	5	M4	4	44	44	

Corrosion-resistant design

Example: standard rail **LML20/1200SB**  
standard carriage **C3RCL16NX**

## Mounting example

Protective doors on machine tool  
U-Line

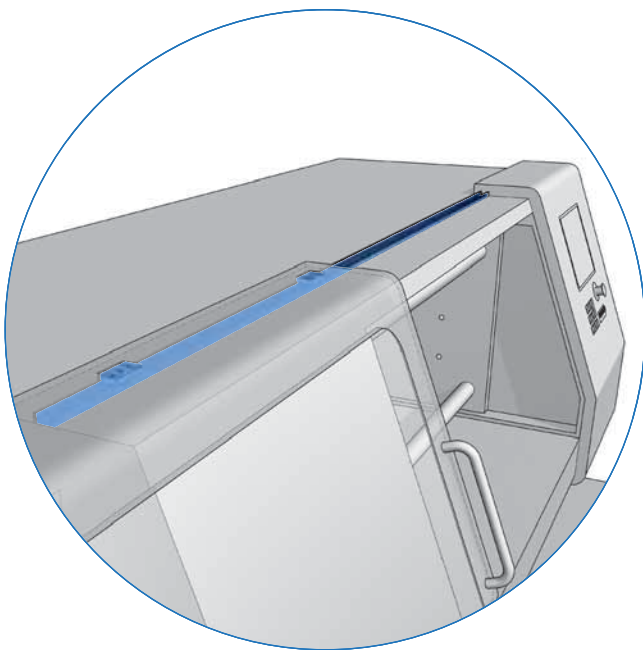
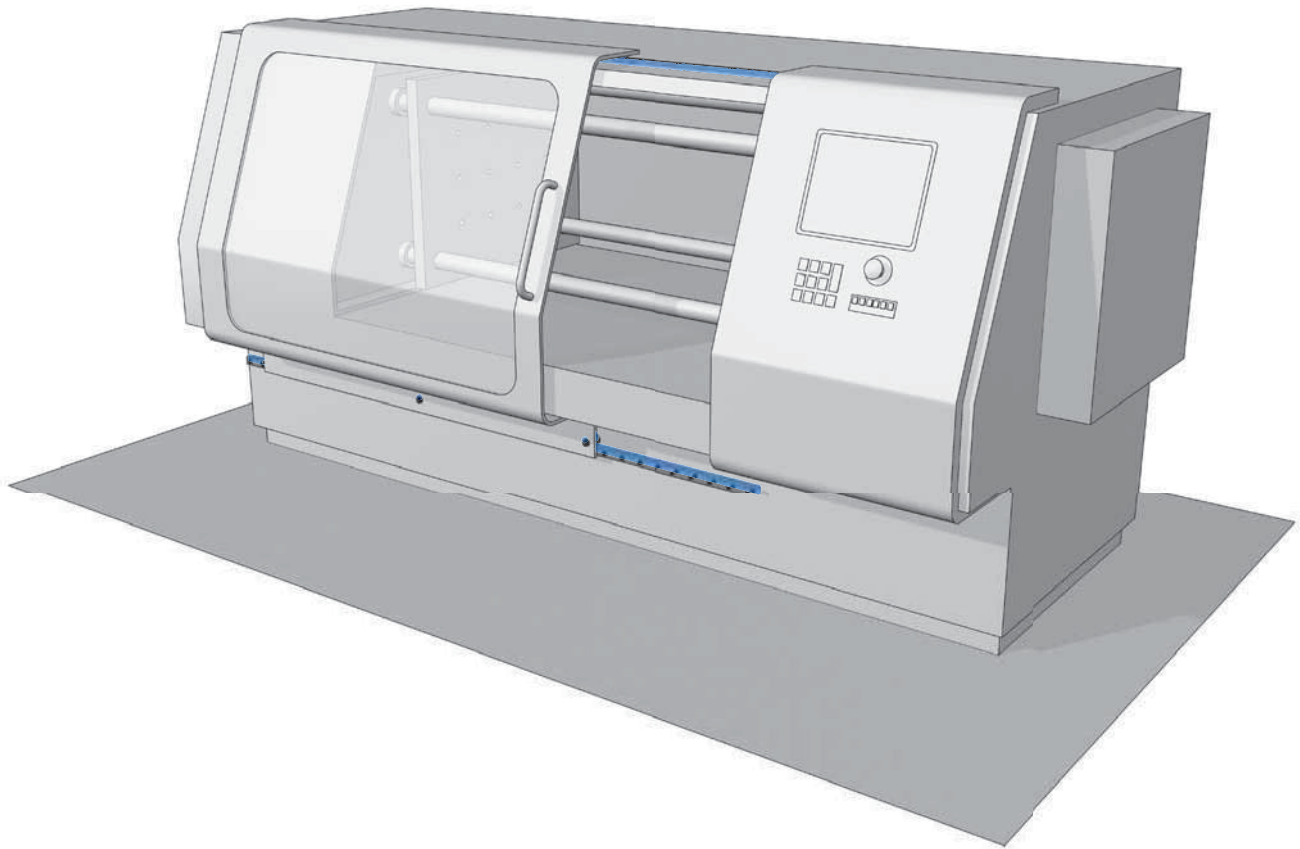

# Product index (in alphabetic order)

Product	Description	Page
<b>BL</b>	Carriage with burnished body for the ROLBLOC system	43
<b>C</b>	Rail composed by an aluminium body and one shaft in steel, with a single raceway for Base-Line system	88
<b>C3RAL, C4RAL</b>	Carriages with body in anodised aluminium with 3 or 4 guide rollers type RAL for auto-aligning system U-Line	116
<b>C3RAS, C4RAS, C5RAS</b>	Carriage with body in anodised aluminium with 3, 4 or 5 guide rollers type RAS for auto-aligning system C-Line	81-82-83
<b>C3RCL, C4RCL</b>	Carriage with body in anodised aluminium with 3 or 4 guide rollers type RCL for U-Line system	116-119
<b>C3RCS, C4RCS, C5RCS</b>	Carriages with body in anodised aluminium with 3, 4 or 5 guide rollers type RCS for auto-aligning system C-Line	81-82-83
<b>C3RYL, C4RYL</b>	Carriage with body in anodised aluminium with 3 or 4 guide rollers type RCL and RAL for auto-aligning system U-Line	116
<b>C3RYS, C4RYS, C5RYS</b>	Carriages with body in anodised aluminium with 3, 4 or 5 guide rollers type RCS and RAS for auto-aligning system C-Line	81-82-83
<b>DC</b>	Rail composed by an aluminium body and two shafts in steel, with two raceways for Base-Line system	87
<b>DIST FS</b>	Spacers for rails FS, FSH and FSR	59
<b>FK</b>	Guide wheel with tapered roller bearings for GP rails of Heavy-Line system	31
<b>FKU</b>	Guide wheel with tapered roller bearings for GU rails of Heavy-Line system	22
<b>FKX</b>	Guide wheel with tapered roller bearings for FSX rails of V-Line system	56
<b>FKY</b>	Guide wheel with tapered roller bearings for FS and FSH rails of V-Line system	56
<b>FR..EU</b>	Guide roller with ball bearings for FS and FSH rails of V-Line system, and FWS and FWH rails of Base-Line system	52-98
<b>FR..EU AS/AZ</b>	Floating guide rollers with ball bearings for FS and FSH rails of V-Line system, and FWS and FWH rails of Base-Line system	53-99
<b>FRL..EU</b>	Floating guide rollers with needle roller bearings for FS and FSH rails of V-Line system, and FWS and FWH rails of Base-Line system	57-100
<b>FRN..EI</b>	Guide roller with needle roller bearings for FS and FSH rails of V-Line system	54
<b>FS..M, FSH..M</b>	Rail in steel with ground raceways, for V-Line system	49-51
<b>FS..MT, FSH..MT</b>	Rail in steel with sandblasted raceways, for V-Line system	48-50
<b>FSR..M</b>	Circular rail in steel, for Multi-Motion-Line system	67
<b>FSRO</b>	Oval circuit composed of linear and circular pieces of rail for Multi-Motion-Line system	69
<b>FSRQ</b>	Ring circuit composed of linear and circular pieces of rail for Multi-Motion-Line system	70
<b>FSX..M</b>	Rail in steel with ground raceways, for V-Line system	51
<b>FSX..MT</b>	Rail in steel with sandblasted raceways, for V-Line system	50
<b>FWH</b>	Rail composed by an aluminium body and one shaft in steel, with a single raceway for Base-Line system	97
<b>FWN</b>	Rail composed by an aluminium body and two shafts in steel, with two raceways for Flexy-Line 645 system	105
<b>FWS</b>	Rail composed by an aluminium body and two shafts in steel, with two raceways for Base-Line system	96
<b>GC</b>	Guide roller with needle roller bearings for GP rails of Heavy-Line system	32-33
<b>GLA</b>	Guide wheel with double row of balls with oblique contact, with "gothic arch" profile for U-Line system	115
<b>GP..M</b>	Rail in steel , ground raceways for Heavy-Line system	29
<b>GP..MC</b>	Rail in steel , rough ground raceways for Heavy-Line system	28
<b>GU..M</b>	Rail in steel , ground raceways for Heavy-Line and Rolbloc system	20-41
<b>GU..MT</b>	Rail in steel , sandblasted raceways for Heavy-Line and Rolbloc system	20-41
<b>LM</b>	Rail composed by an aluminium body and two shafts in steel, with two internal raceways for U-line system	112
<b>LML</b>	Rail totally in aluminium with two internal raceways for U-line system	119
<b>LS</b>	Rail in steel with internal raceways for C-Line system	78
<b>LUBC</b>	Lubricator for Base-Line system (guide rollers running on C and DC rails)	93
<b>LUBM</b>	Lubricator for U-Line system (carriages running in LM rails)	117
<b>LUBP</b>	Lubricator for Heavy-Line system (guide rollers running on GP rails)	36
<b>LUBU</b>	Lubricator for Heavy-Line system (guide rollers running on GU rails)	24
<b>LUBX, LUBY</b>	Lubricator for V-Line system (guide rollers running on FS and FSH rails)	60-61
<b>MBL</b>	Carriage with black anodised aluminium body and three guide rollers with ball bearings, for Rolbloc system	42
<b>NAID</b>	Wipers for C and DC rails of Base-Line system	92

# Product index (in alphabetic order)

Product	Description	Page
<b>PFV gothic profile</b>	Guide roller with “gothic arch” profile, based on ball bearings, for C and DC rails of Base-Line system, and LM rails of U-Line system	89-113
<b>PK</b>	Guide roller with tapered roller bearings for GP rails of Heavy-Line system	30
<b>PR</b>	Adjustment plates for BL carriages of Rolbloc system	44
<b>RAL</b>	Floating guide rollers with “gothic arch” profile, with a double row of balls with oblique contact, for LM rails of U-Line system	114
<b>RAS</b>	Floating guide rollers with balls for LS rails of C-Line system	80
<b>RCL</b>	Guide rollers with “gothic arch” profile, with a double row of balls with oblique contact, for LM rails of U-Line system	113
<b>RCP</b>	Guide rollers with balls for LS rails of C-Line system	113
<b>RCS</b>	Guide rollers with balls profile, for LS rails of C-Line system	79
<b>RKO</b>	Guide rollers with tapered roller bearings, with “gothic arch” profile for C and DC rails of Base-Line system	90
<b>RKU</b>	Guide rollers with tapered roller bearings, for GU rails of Heavy-Line system	21
<b>RKUL</b>	Floating guide rollers with tapered roller bearings for GU rails of heavy line system	23
<b>RKX</b>	Guide rollers with tapered roller bearings, for FSX rails of V-Line system	55
<b>RKY</b>	Guide rollers with tapered roller bearings, for FS and FSH rails of V-Line system	55
<b>RKYL, RKXL</b>	Floating guide rollers with tapered roller bearings for FS.. rails of V-Line system	58
<b>SAG</b>	Guide pins for the mounting alignment of GU rails of Heavy-Line system	25
<b>TA4, TB4</b>	Carriages with anodised aluminium body with four guide rollers type GLA for FWN rails of Flexi-Line system	106-107
<b>T4FR</b>	Carriages with anodised aluminium body with four guide rollers type FR..EI for FWS rails Base-Line system	101
<b>T4PFV</b>	Carriages with anodised aluminium body with four guide rollers type PFV with “gothic arch” profile for C and DC rails of Base-Line system, and LM rails of U-Line system	91
<b>T4R...</b>	Steering carriage for FSR..M circular rails of Multi-Motion-Line system	71
<b>T4RAL</b>	Carriages with black anodised aluminium body with four floating guide rollers type RAL with “gothic arch” profile for LM rails of U-Line system	117
<b>T4RCL, T4RCP</b>	Carriages with black anodised aluminium body with four guide rollers type RCL or RCP with “gothic arch” profile for LM rails of U-Line system	117
<b>T4RYL</b>	Carriages with black anodised aluminium body with four guide rollers type RCL/RCP and RAL with “gothic arch” profile for LM rails of U-Line system	117

# Suffix index (in alphabetic order)

<b>A</b>	Standard hole pattern according to the catalogue for GP rails
<b>AC</b>	Hollow shafts optional for rails C, DC and LM
<b>B</b>	Standard hole pattern according to the catalogue for GP rails
<b>CH</b>	Chromium plated shafts
<b>D</b>	Felt without lubricant
<b>GZ</b>	Surface zinc-plated for LS rails (C-Line)
<b>M</b>	Ground profile
<b>MC</b>	Rough ground profile (for GP rails)
<b>MT</b>	Drawn and sandblasted profile
<b>NF</b>	Rails without holes
<b>NX</b>	Stainless steel version for guide rollers or guide rails
<b>NW</b>	Chemical Nickel-plating
<b>NZ</b>	Finishes to drawing
<b>R</b>	Ground on one end
<b>RR</b>	Ground on both ends
<b>SB</b>	Standard hole pattern according to the catalogue
<b>UU</b>	Felts for lubrication available (for carriages TA4 and TB4 of Flexi-Line 645 system)
<b>V</b>	Seals in Viton



# Note

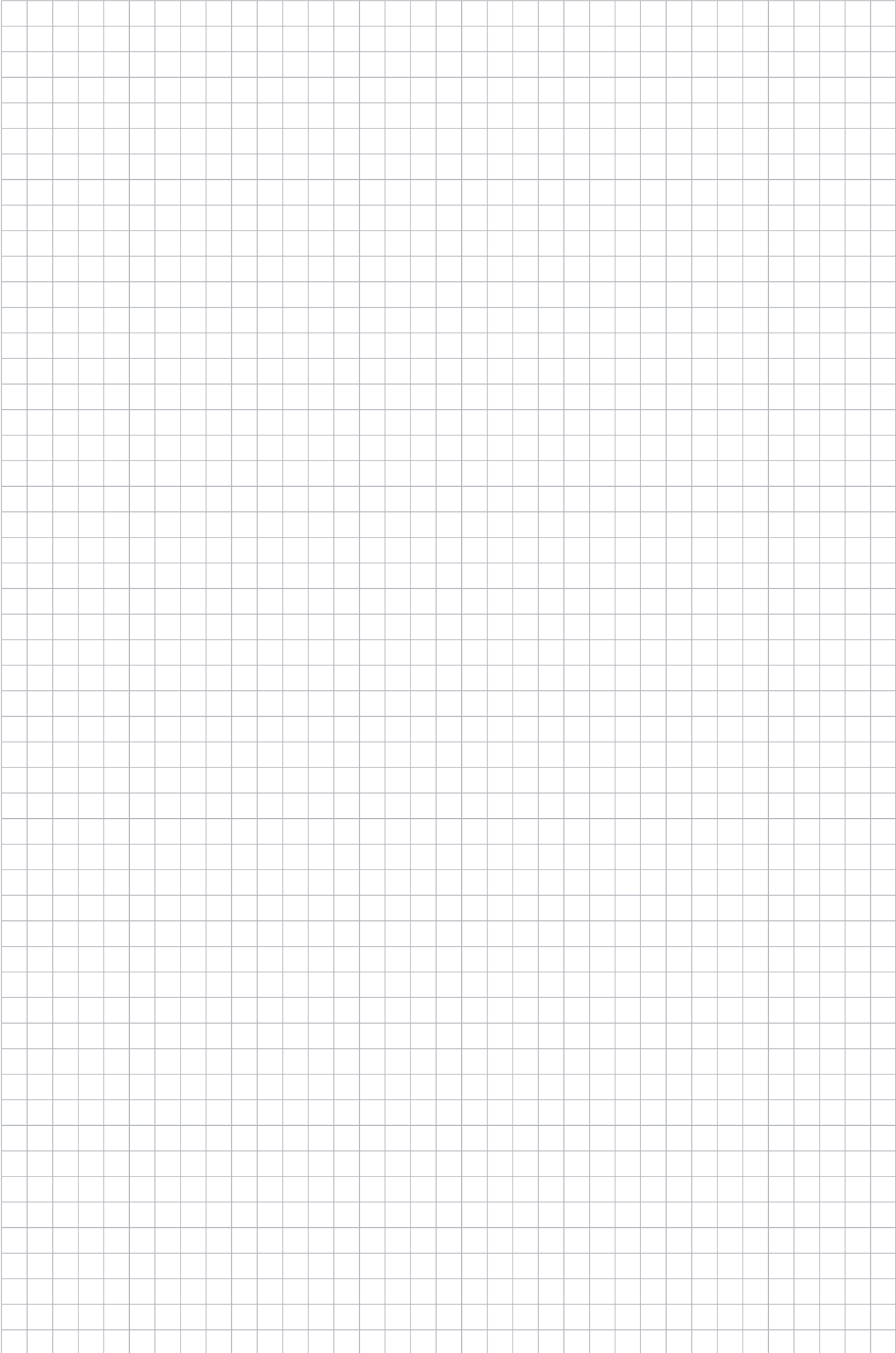

# Note

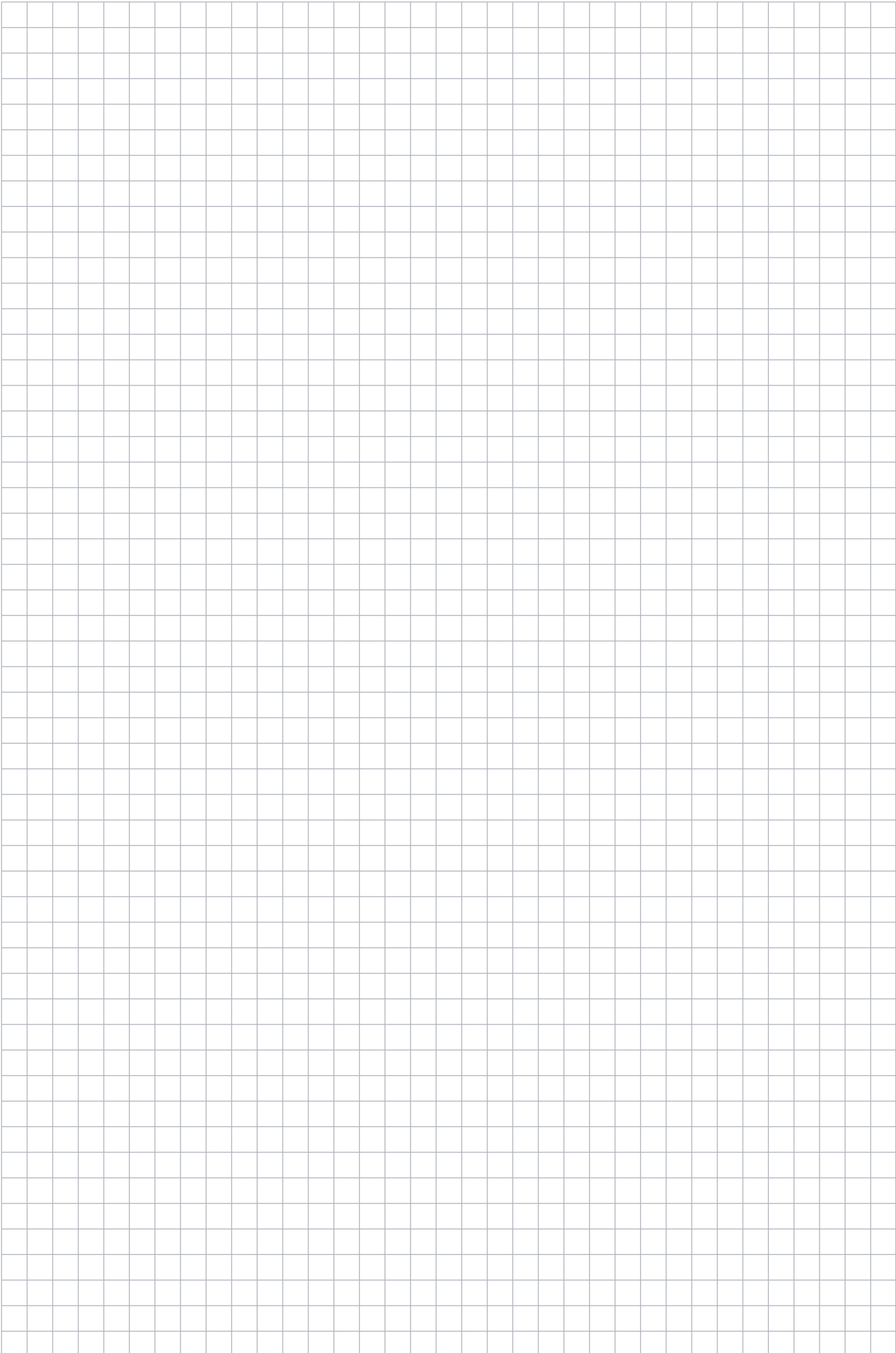

# **3D CAD DRAWINGS**

*Our 2D and 3D drawings can be  
down loaded from our web site:*

**[www.nadella.eu](http://www.nadella.eu)**

## ■ Nadella S.r.l.

Via Melette, 16  
20128 Milano  
Tel. +39 02.27.093.297  
Fax +39 02.25.51.768  
customer.service@nadella.it  
www.nadella.it

## ■ Nadella GmbH

Rudolf-Diesel-Straße 28  
71154 Nufringen  
Tel. +49 (0)70 32 95 40-0  
Fax +49 (0)70 32 95 40-25  
info@nadella.de  
www.nadella.de

## ■ Nadella Inc.

4884 Hawkins Road  
Jackson, MI 49201 - USA  
Toll Free +1 866 828 0611  
Fax +1 (517) 764 0806  
info@nadella.com  
www.nadella.com

## ■ Nadella Office Shanghai

728 German Centre, 88 Keyuan Road  
Pudong Shanghai 201203  
Tel. +86 21 2898 6196  
Tel. +86 21 2898 6199  
info@nadella.cn.com  
www.nadella.cn.com

## NADELLA WORLDWIDE ORGANISATION

### Europe:

- Austria
- Czech Republic
- Denmark
- Finland
- France
- Germany
- Hungary
- Italy
- Netherlands
- Norway
- Poland
- Romania
- Slovakia
- Slovenia
- Spain
- Sweden
- Switzerland
- Turkey
- United Kingdom



- Head office
- Branches and distributors