

THE SPECIALIST  
FOR MOTION  
TECHNOLOGY

# AXNR CIRCULAR SYSTEM

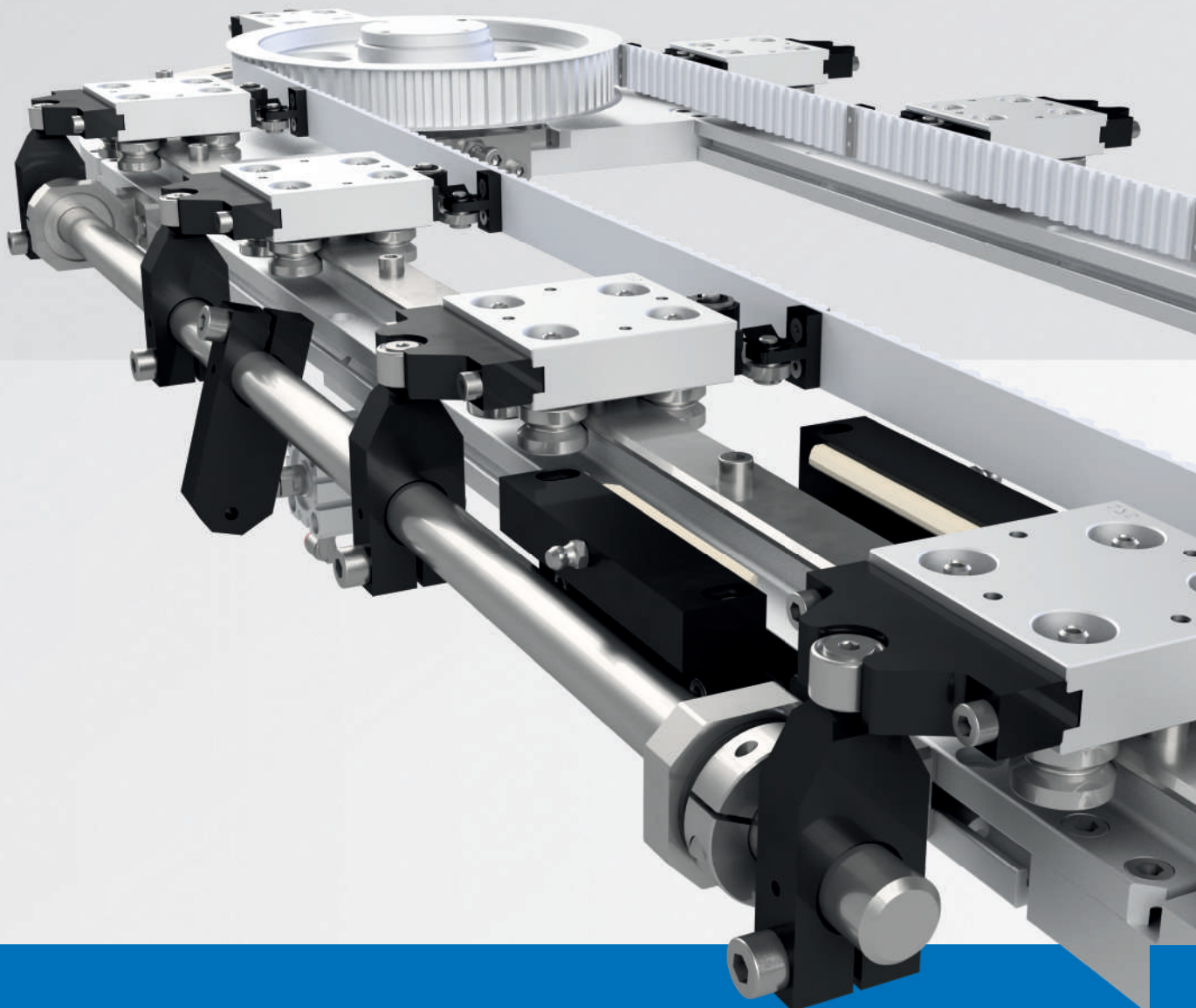



# SUMMARY



<b>PAGE 04</b>	<b>1.0 NADELLA GROUP</b>
<b>PAGE 06</b>	<b>2.0 PRODUCT OVERVIEW</b>
<b>PAGE 10</b>	<b>3.0 SYSTEM CONFIGURATION</b> <ul style="list-style-type: none"><li>• Circular rail FSRO and FSRQ</li><li>• Carriages</li><li>• Basic configurations</li></ul>
<b>PAGE 16</b>	<b>4.0 CIRCULAR SYSTEMS</b> <ul style="list-style-type: none"><li>• Circular system AXNRO</li><li>• Circular system AXNRQ</li><li>• Carriage T4R</li><li>• Load, moments and operating temperature</li></ul>
<b>PAGE 24</b>	<b>5.0 TECHNICAL FEATURES</b> <ul style="list-style-type: none"><li>• Drive connections and positioning system</li><li>• Circular system selection</li><li>• Applications</li><li>• Order codes</li></ul>

THE SPECIALIST FOR MOTION TECHNOLOGY

Nadella Group is an expert system partner for all areas of motion technology, with specialized manufacturer companies and a worldwide sales network.

Wherever innovative ideas, customized solutions, precision and reliability are required, developers and design engineers rely on products and solutions from the Nadella Group.

COMPANIES, BRANDS AND PRODUCTS OVERVIEW



**durbal**

Linear Guide Systems



Linear Modules



Complete Systems



Bearings and Cam Followers



Adjusting Nuts & Rings



Telescopic Rails



**TESCUBAL**



Rod Ends and Spherical Plain Bearings



Clevises and Ball/Axial Joints



Precision Ball Screws



Rolled Ball Screws

MILESTONES

**1930**

NADELLA foundation in France

**1958**

Founding of NADELLA GMBH in Germany

**1963**

Founding of NADELLA S.P.A. in Italy

**1984**

Start of development and sale of Nadella Linear

**2012**

New Nadella subsidiaries in China and USA

**2014**

Acquisition of DURBAL

**2018**

Acquisition of CHIAVETTE UNIFICATE

**2019**

Founding of Nadella Motion Technology Changxing Co. Ltd.

**2020**

New Nadella subsidiaries in France and Spain  
Acquisition of SHUTON and IPIRANGA

**2021**

Acquisition of DAMO

KEY NUMBERS

1 Group

8 manufacturing plants

14 main locations  
Italy, Germany, France, United Kingdom, Spain, United States, China

leading the way in the international markets

in over 60 countries

for more than 90 years

APPLICATION SECTORS



RAILWAY TECHNOLOGY



WAREHOUSE & LOGISTICS



MEDICAL ENGINEERING



FOUNDRY & IRONWORKS



ROBOTICS AUTOMATION



PACKAGING INDUSTRY



AEROSPACE TECHNOLOGY



PHARMACEUTICAL PRODUCTION



CUTTING & WELDING



HI-TECH PRODUCTION

## THE SPECIALIST FOR MOTION TECHNOLOGY

Our customers' satisfaction is the basis for our success and growth. That is why we are at your service around the world and always keep your requirements as a priority.

We have a worldwide network of sales engineers and distributors in Europe, Asia and the USA. This allows us to ensure customer-oriented solutions and best in class delivery and service.

## WORLDWIDE NETWORK



## BRANCHES AND CONTACTS

### NADELLA S.p.A. Italy

Via Melette, 16  
20128 Milano  
Tel.: +39 02 27 093  
Fax: +39 02 257 64 79  
customer.service@nadella.it  
www.nadella.it

### NADELLA S.A. Spain

Poligono Industrial Erratzu  
Parcela G3. Pabellón 221 - Apdo.65  
E-20130 Urnieta - Gipuzkoa  
Tel. +34 943 336 370  
ventas@nadella.es  
www.nadella.com

### NADELLA GmbH Germany

Rudolf-Diesel-Str. 28  
71154 Nufringen  
Tel.: +49 7032 9540-0  
Fax: +49 7032 9540-25  
info@nadella.de  
www.nadella.de

### DURBAL Metallwarenfabrik GmbH - Germany

Verrenberger Weg 2  
74613 Öhringen  
Tel.: +49 7941 9460-0  
Fax: +49 7941 9460-90  
info@durbal.de  
www.durbal.com

### NADELLA Inc. United States

14115 - 63 Way North  
Clearwater - Florida 33760-3621  
Tel.: +1 844-537-0330 (toll-free)  
Tel.: +1 844-537-0331  
info@nadella.com  
www.nadella.com

### CHIAVETTE UNIFICATE S.p.A. Italy

Via G. Brodolini 6-8-10  
40069 Zola Predosa, Bologna  
Tel.: +39 051 75 87 67  
Fax: +39 051 75 47 80  
tescubal@chivette.it  
www.chivette.com

### NADELLA Linear Shanghai Co. Ltd. - China

Room D314, No. 245 Xinjunhuan  
RoadMinhang, Shanghai 201114  
Tel.: +86 21 5068 3835  
Fax: +86 21 5038 7725  
info@nadellalinear.com  
www.nadella.cn.com

### SHUTON S.A. Spain

Poligono Industrial Erratzu  
C/Subino, 5 - 01170 LEGUTIANO  
Tel.: +34 945 465 629  
Fax: +34 945 465 610  
shuton@shuton.com  
www.shuton.com

### NADELLA Sarl France

12 Parvis Colonel Arnaud Beltrame  
Hall A 4ème étage  
78000 Versailles  
Tel.: +33 (0)1 7319 4048  
service.client@nadella.fr  
www.nadella.fr

### HUSILLOS IPIRANGA Spain

Poligono Industrial Erratzu  
Parcela G3. Pabellón 221 - Apdo.65  
E-20130 Urnieta - Gipuzkoa  
Tel. +34 943 336 370  
info@ipirangahusillos.com  
www.ipirangahusillos.com

## DISTRIBUTORS COVERAGE

Austria	China	France	India	Korea	Portugal	Slovakia	Switzerland
Belgium	Czech Republic	Germany	Ireland	Netherlands	Romania	Slovenia	Taiwan
Brazil	Denmark	Great Britain	Israel	Norway	Russia	Spain	Turkey
Canada	Finland	Hungary	Italy	Poland	Singapore	Sweden	United States



# PRODUCT OVERVIEW



**PAGE 8**

## **2.1 PRODUCT OVERVIEW**

- Circular systems
- Carriages

**PAGE 9**

## **2.2 PRODUCT DESCRIPTION**

## PRODUCT OVERVIEW

### CIRCULAR SYSTEMS

Type		PAGE
AXNRO		18
AXNRQ		20

### CARRIAGES

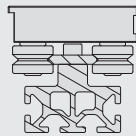
Type		PAGE
T4R		22

# PRODUCT DESCRIPTION

Nadella AXNR circular module is a further development of Nadella FSR circular rails.

AXNR module is a reliable and cost competitive solution.

The product is based on the combination of standard components to allow product definition and availability in short time.

Modification or special version to meet specific requirement are anyway possible.

The Nadella AXNR circular system is composed of groups of standard elements: aluminium basement, guide rails and carriages, transmission by gearbox and toothed belt, lubrication units and carriage indexing for precise carriage location.

AXNR circular system has following outstanding advantages:

- Nadella as leader in the V guides market provides guide rollers characterized by high load capacity, stiffness and precision, necessary to obtain regular movements and accurate positioning.
- Depending on the configuration, a special rod end design of connection between toothed belt and carriages provides a steady and smooth moving of entire system.
- Aluminium alloy machined base directly connected to the gearbox lead to a space-saving system, meanwhile a steady and easy-mounting solution.
- Customized solution and complete system are available thanks to flexible configuration

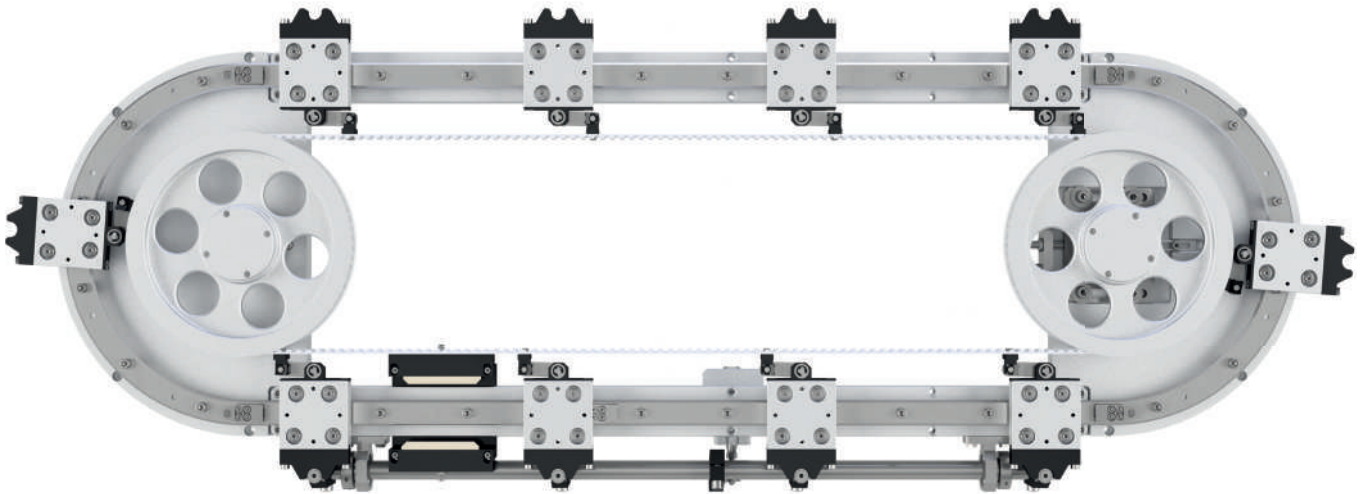

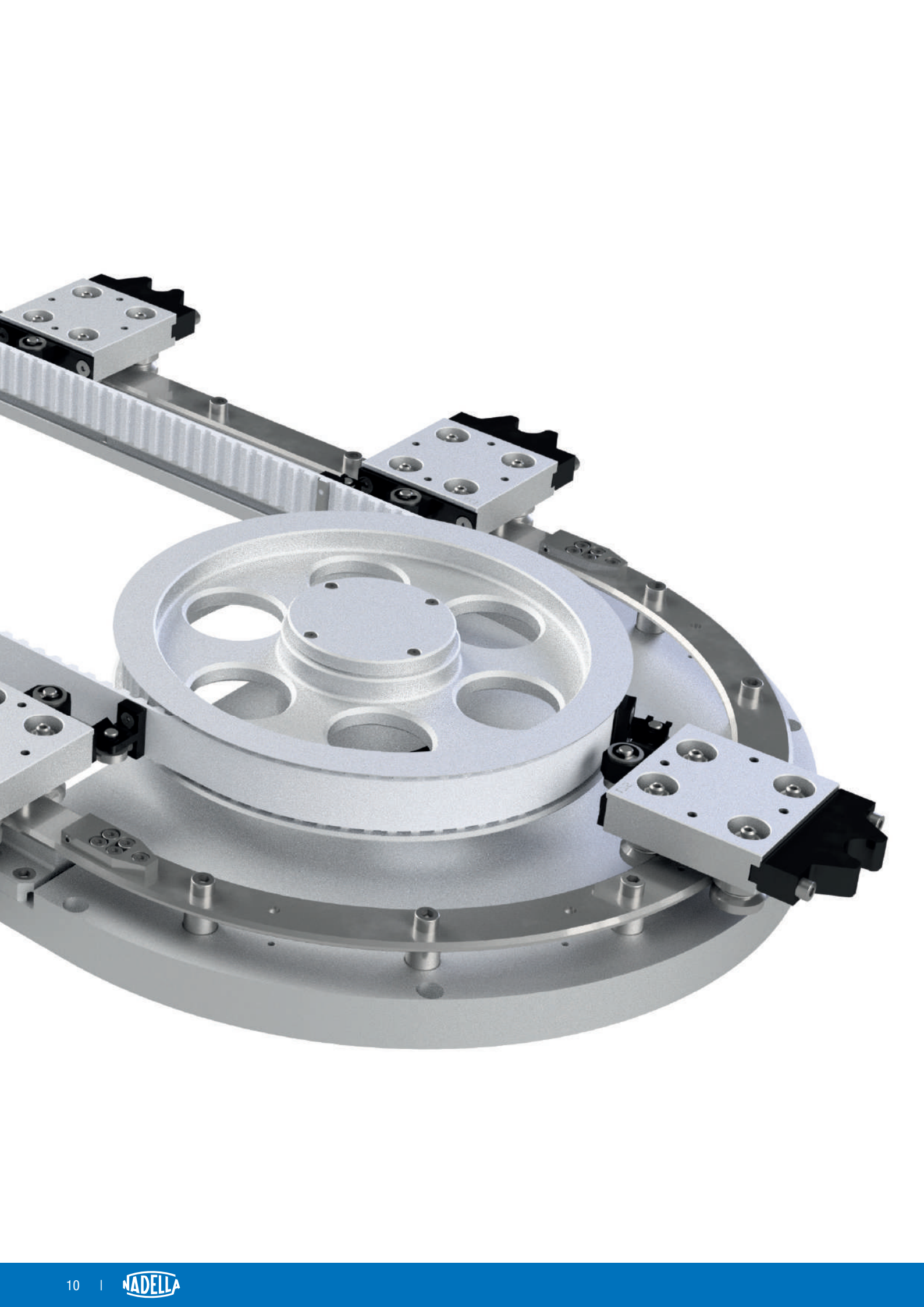

# SYSTEM CONFIGURATION

# 3

PAGE 12

3.1 CIRCULAR RAIL FSRO AND FSRQ

PAGE 13

3.2 CARRIAGES

PAGE 14

3.3 BASIC CONFIGURATION

# SYSTEM CONFIGURATION

## CIRCULAR RAIL FSR0 AND FSRQ

# 3.1

Circular rails are induction hardened on raceway to achieve life and ground to improve surface finish and accuracy. Circular rails are composed of both circular and straight parts. When the systems dimensions become excessive for shipment in a preassembled unit alignment blocks provide a simple way to align the joints between two parts. In this case it's convenient to ask for a short removable piece of rail to simplify the carriage insertion on the assembled unit (Option 13).

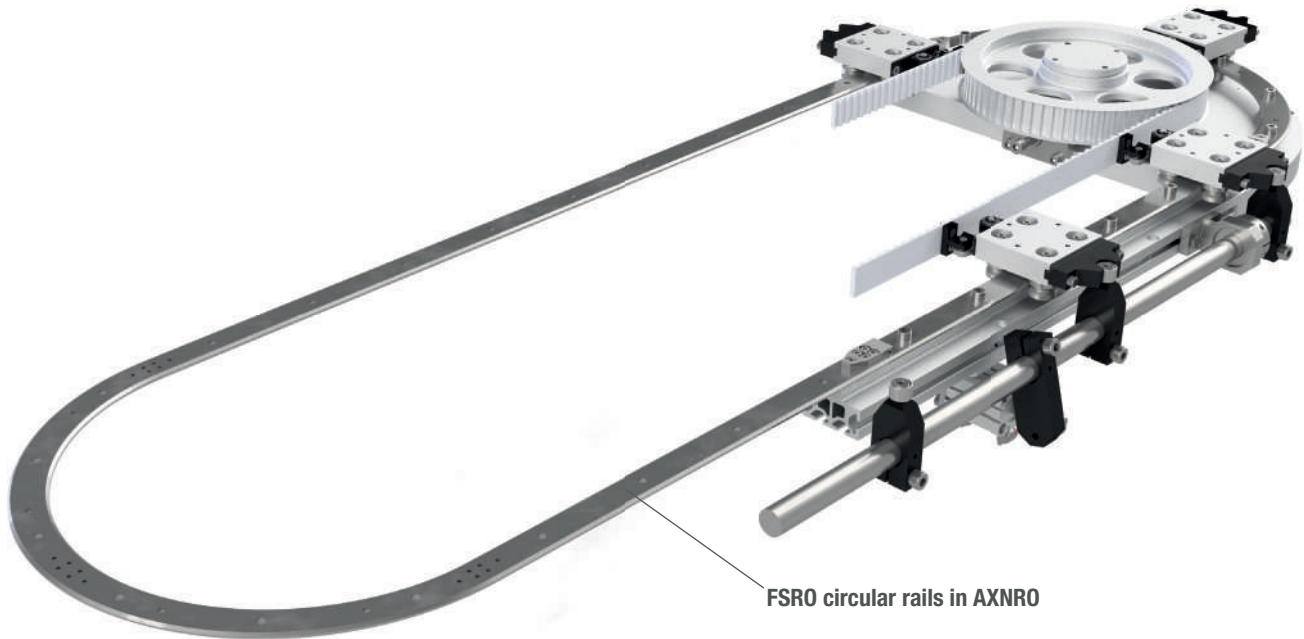

Nadella circular module AXNRO is made of oval circuit FSR0. AXNRQ is made of ring circuit FSRQ.

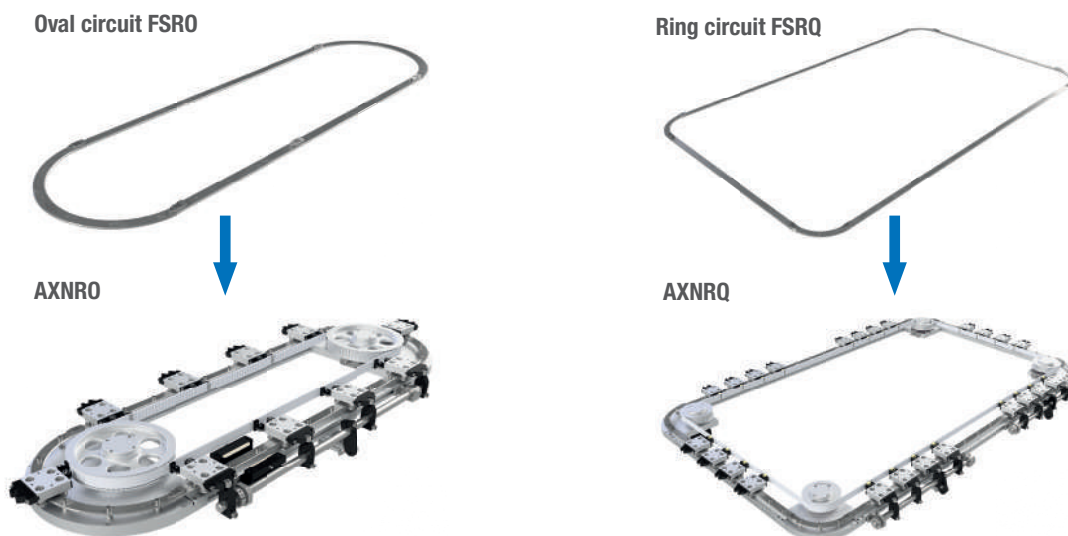

## SYSTEM CONFIGURATION CARRIAGES

Carriages equipped with Nadella guide rollers supporting the load in all directions. Standard carriages with rollers in fixed position to allow precise movement in the round and in the straight section of the guide rail circuit. Carriage preload is set already in the factory for a ready to use product.

The carriage is equipped with two concentric guide rollers and two eccentric guide rollers. The eccentric guide rollers are mounted on the inner side of the circuit and allow to set the preload.

Normal preload is registered already in the factory for a ready to use product, but on request higher or lower preload can be required.

The preload remains constant on the straight and on the round path, but during the transition, when two rollers are on the round rail and the other two are on the straight rail, the preload is lost and a small play between the rollers and the guide occurs.



Concentric roller FR...EU



Eccentric roller FRR...EU

The carriage body is based on an anodized aluminium plate. Additional machining as reference holes can be easily done. Special carriage design to fit the application requirement are always feasible.

## CORROSION RESISTANT CARRIAGES

Guides and guide rollers in stainless steel are part of the standard Nadella range and carriages in anticorrosion version can be easily configured.

Most applications with anticorrosion requirement use stainless steel rollers in aluminium table and other steel components, as the cam for carriage location, protected by nickel plating. Fully stainless solution can be provided on request.

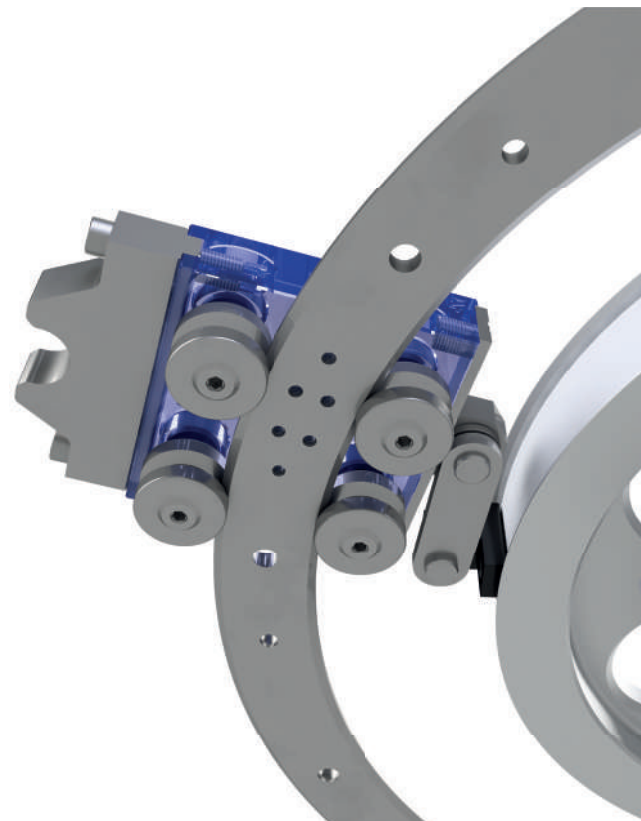

# SYSTEM CONFIGURATION

## BASIC CONFIGURATION

### TRANSMISSION

Carriage traction is based on toothed belt for silent and maintenance free transmission. Design focused to reduce the distance from the belt to the carriage in order to minimize the peak-load on the carriage connection at high speed during the transition from round to straight path.

Carriage distance has to be a multiple of the belt pitch: 10 mm up to rail radius 300 mm and 20 mm for radius 400 and 500. The length of the module depends from the length of the belt. For carriages at constant pitch, the most common configuration, the belt length is calculated as the number of carriages by their pitch. The module length will fit the required belt length.

### FLOATING CONNECTION

Toothed belt and carriages are linked by a floating connection to provide a reliable movement and the compensation of distance between belt and carriage on the round path.

Two types of connectors available: A type based on rod end and B type based on direct engagement.

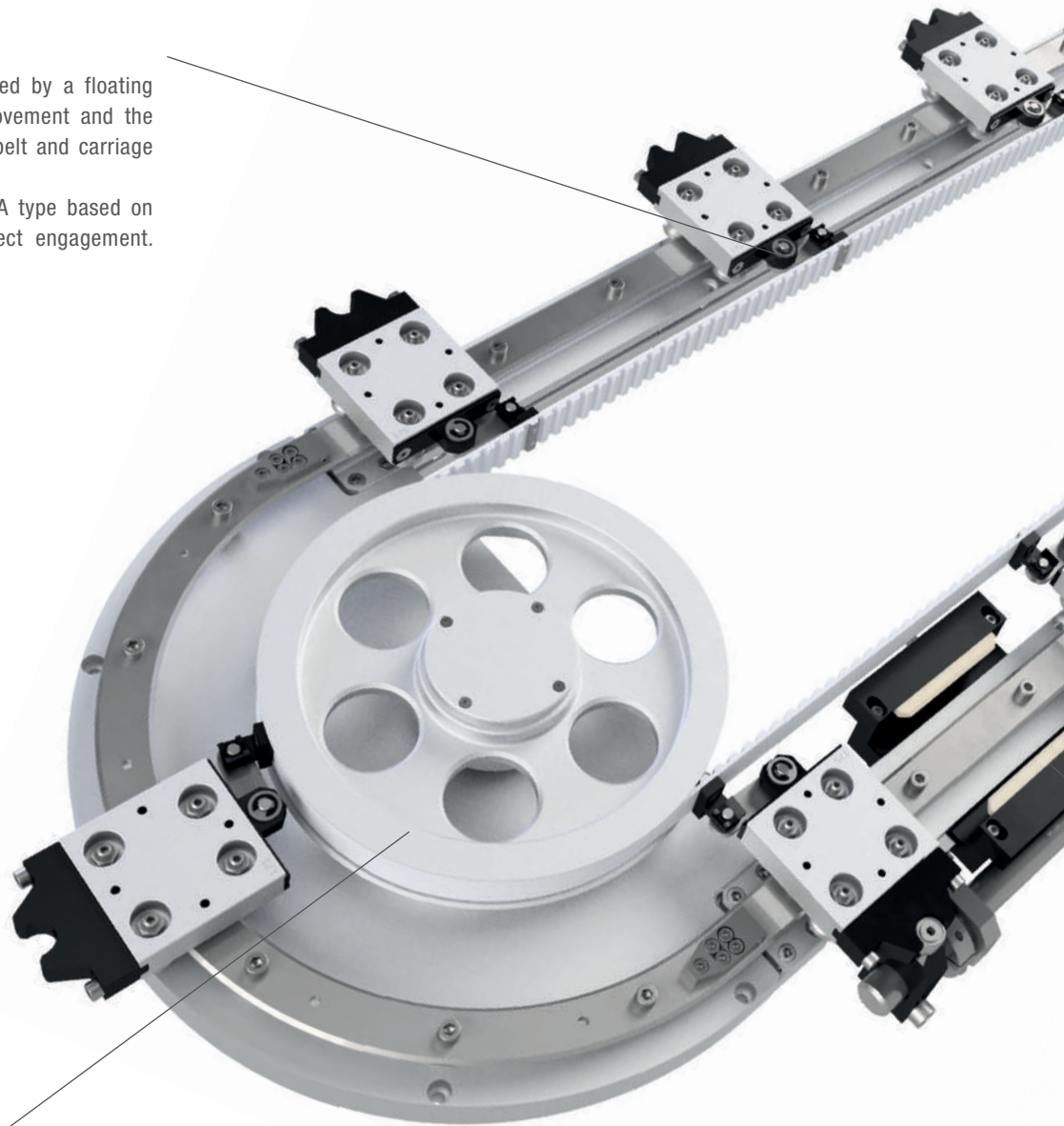

### DYNAMIC SYSTEM

Drive pulley directly mounted on the gear box output shaft for maximum integration. First class gear box to achieve high dynamic and accuracy performances are delivered configured already with the proper interface for the specific customer motor.

On request specific gear box can be supplied.

## ALUMINIUM ALLOY BASE

The module basement is made in aluminium. It is composed by the main plates supporting the pulleys and the profiles to support the linear guide rails. It's a compact solution that allows to save space in the equipment.

For long modules it's necessary to support the module to avoid excessive stress and deformation in the structure.

The extruded profiles supporting the linear rails have T slots along their length used to fix options as lubricators and carriage indexing cam in any position.

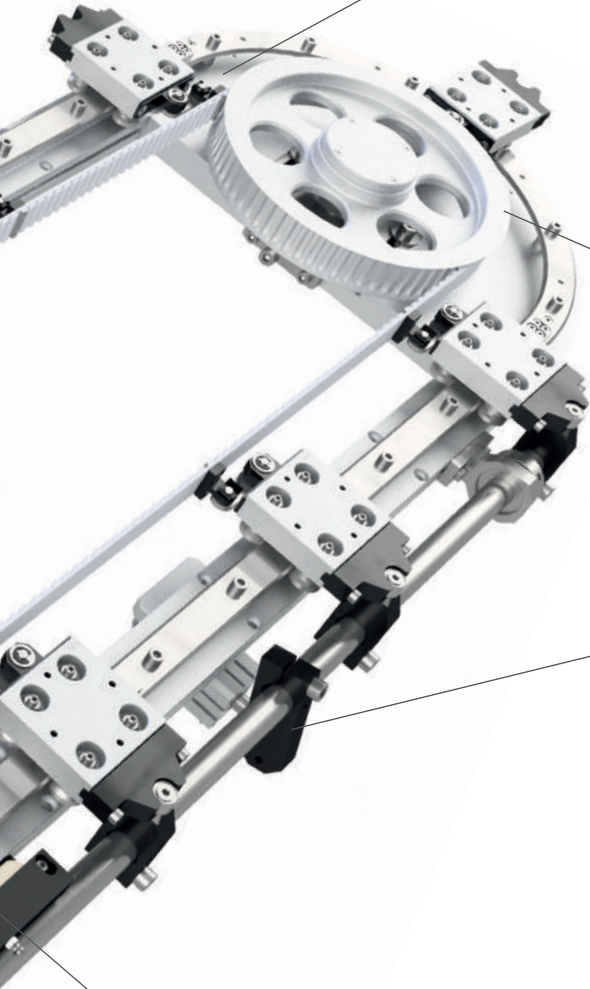

## IDLER PULLEY

Idler pulley is mounted on a slide to allow belt tensioning.

## POSITIONING SYSTEM (OPTIONAL)

The positioning system guarantees the repeating accuracy of carriage position

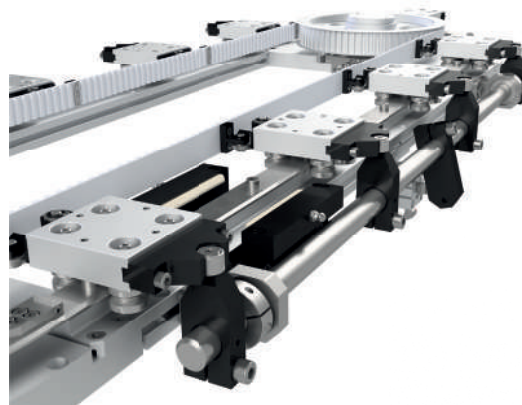

## LUBRICATION

Nadella LUBR system is an easy mounting solution. The lubrication oil stored in the foam is directly released to the surface of the guide rollers minimizing the oil consumption. The reservoir effect of the foam allows to reduce the maintenance activity for lubrication.

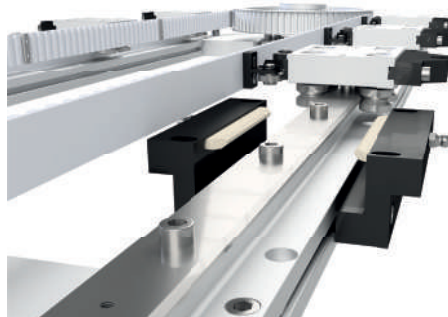

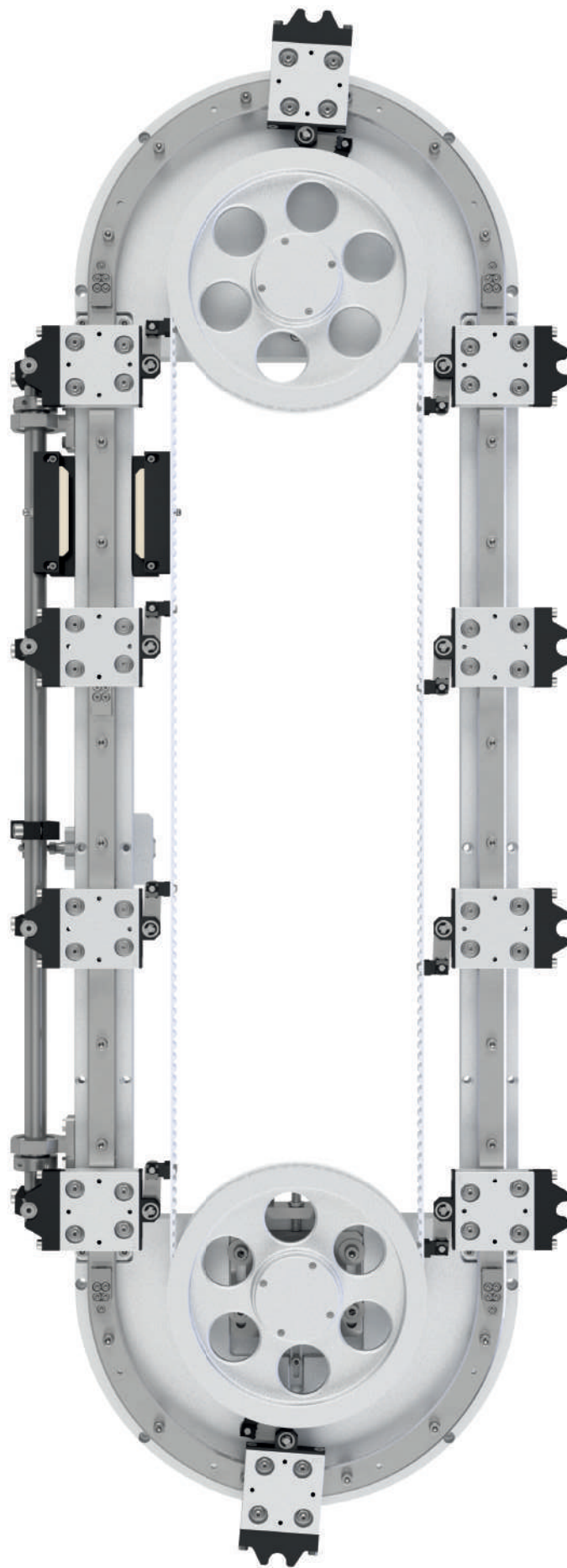

# CIRCULAR SYSTEMS

# 4

PAGE 18

4.1 CIRCULAR SYSTEM AXNRO

PAGE 20

4.2 CIRCULAR SYSTEM AXNRQ

PAGE 22

4.3 CARRIAGE T4R

PAGE 23

4.4 LOAD, MOMENTS AND OPERATING TEMPERATURE

# CIRCULAR SYSTEMS

## AXNRO

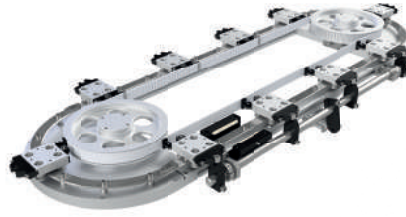

Available in  
EVO version

**EVO**

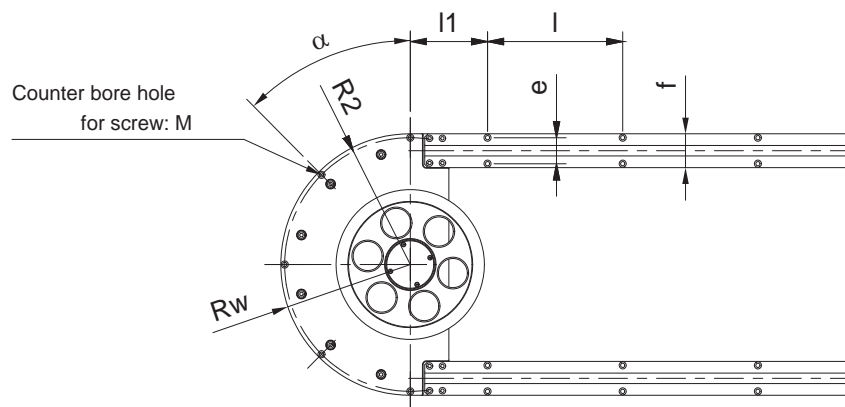
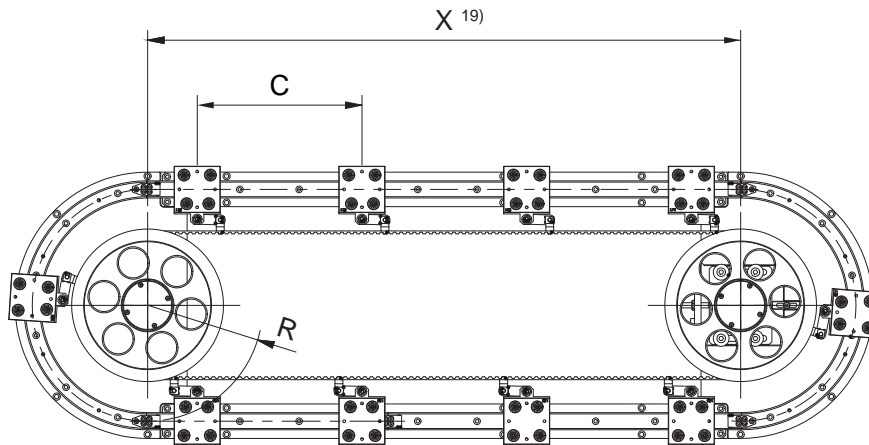
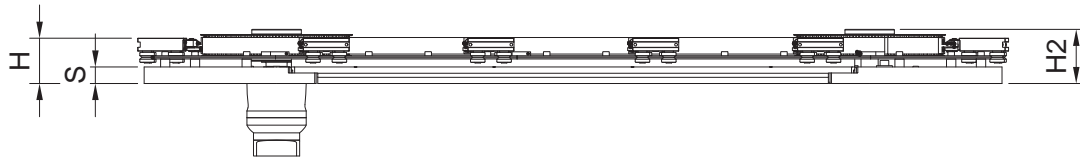

# 4.1

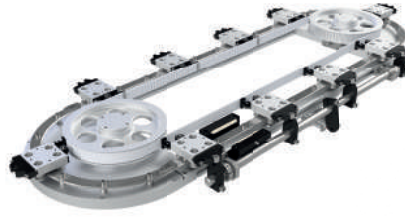

Available in  
EVO version

**EVO**

Type	R <sup>1)</sup> mm	R <sub>w</sub> <sup>2)</sup> mm	GRS <sup>3)</sup>	BT <sup>4)</sup>	Z <sup>5)</sup>	H <sup>6)</sup> mm	H <sub>2</sub> <sup>7)</sup> mm	S mm	R <sub>2</sub> <sup>8)</sup> mm	α <sup>9)</sup> °	f <sup>10)</sup>	l <sub>1</sub> <sup>11)</sup> mm	l <sup>12)</sup> mm	d <sup>13)</sup> mm	D <sup>14)</sup> mm	h <sup>15)</sup> mm	e <sup>16)</sup> mm	WxL <sup>17)</sup> kg	WxAL <sup>18)</sup> kg
AXNRO 75	75	101	FS22M	AT10-25	17	68,5	80	25	95	60x3	52	120	200	6,6	11	4	40	14,3	6,6
AXNRO 125	125	151	FS22M	AT10-25	40	68,5	82	25	145	45x4	52	120	200	6,6	11	4	40	19,7	6,6
AXNRO 175	175	201	FS22M	AT10-25	70	68,5	82	25	195	45x4	52	120	200	6,6	11	4	40	27,4	6,6
AXNRO 225	225	265	FS35M	AT10-32 / AT20-32	85 / 42	83	95	25	256	45x4	80	140	200	9	15	8/21	62	54,4	13
AXNRO 300	300	340	FS35M	AT10-32 / AT20-32	130 / 64	83	95	25	331	45x4	80	148	200	9	15	8/21	62	73,0	13
AXNRO 400	400	460	FS47M	AT20-50	90	102	125	30	450	22,5x8	120	168	200	11	18	10/26	100	186	24,5
AXNRO 500	500	560	FS47M	AT20-50	120	102	125	30	550	22,5x8	120	172	200	11	18	10/26	100	245	24,5

1) Circular guide radius

2) Aluminum base radius

3) Guide rail size

4) Belt Type

5) Number of teeth in pulley Z

6) See the technical drawing at page 22 for details

7) Distance between module mounting surface and upper surface of belt wheel

8) Distribution radius of mounting hole

9) Distribution angle of mounting hole

10) Aluminum beam width

11) Hole spacing at the beginning of line segment

12) Hole spacing of straight line

13) Counterbore hole perforation diameter

14) Counterbore hole diameter

15) Counterbore hole depth

16) Hole spacing

17) Approximate weight for module length X = 1 m (without carriages)

18) Weight for additional length

19) Length of module in X direction. Length is the distance between the rail centres, see page 30 for details and calculation method

# CIRCULAR SYSTEMS

## AXNRQ

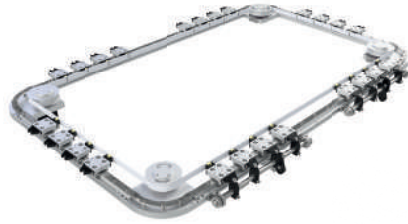

Available in  
EVO version

**EVO**

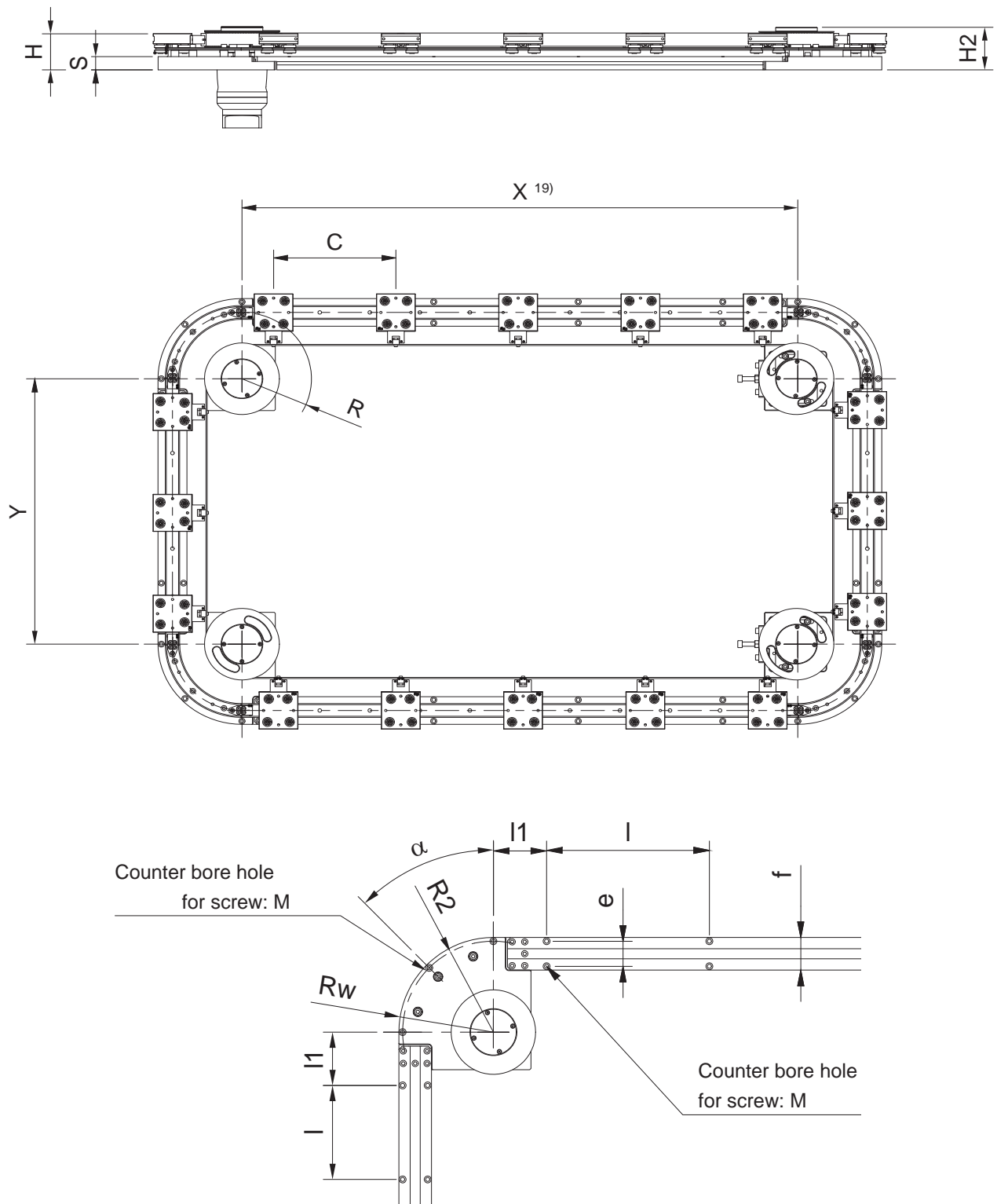

# 4.2

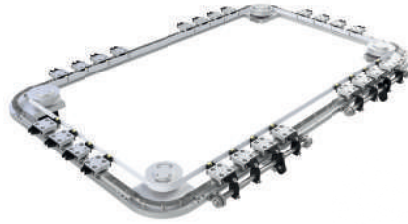

Available in  
EVO version

**EVO**

Type	R <sup>1)</sup> mm	R <sub>w</sub> <sup>2)</sup> mm	GRS <sup>3)</sup>	BT <sup>4)</sup>	Z <sup>5)</sup>	H <sup>6)</sup> mm	H <sub>2</sub> <sup>7)</sup> mm	S mm	R <sub>2</sub> <sup>8)</sup> mm	α <sup>9)</sup> °	f <sup>10)</sup>	l <sub>1</sub> <sup>11)</sup> mm	l <sup>12)</sup> mm	d <sup>13)</sup> mm	D <sup>14)</sup> mm	h <sup>15)</sup> mm	e <sup>16)</sup> mm	W <sub>xL</sub> <sup>17)</sup> kg	W <sub>xAL</sub> <sup>18)</sup> kg
AXNRQ 75	75	101	FS22M	AT10-25	17	68,5	80	25	95	45x2	52	120	200	6,6	11	6	40	23,4	6,6
AXNRQ 125	125	151	FS22M	AT10-25	40	68,5	82	25	145	45x2	52	120	200	6,5	11	6	40	32,9	6,6
AXNRQ 175	175	201	FS22M	AT10-25	70	68,5	82	25	195	45x2	52	128	200	6,6	11	6	40	43,5	6,6
AXNRQ 225	225	265	FS35M	AT10-32 / AT20-32	85 / 42	83	95	25	256	45x2	80	140	200	9	15	8/21	62	76,9	13
AXNRQ 300	300	340	FS35M	AT10-32 / AT20-32	130 / 64	83	95	25	331	45x2	80	160	200	9	15	8/21	62	106	13
AXNRQ 400	400	460	FS47M	AT20-50	90	102	125	30	450	22,5x4	120	190	200	11	18	10/26	100	276	24,5
AXNRQ 500	500	560	FS47M	AT20-50	120	102	125	30	550	22,5x4	120	215	200	11	18	10/26	100	370	24,5

1) Circular guide radius

2) Aluminum base radius

3) Guide rail size

4) Belt Type

5) Number of teeth in pulley Z

6) See the technical drawing at page 22 for details

7) Distance between module mounting surface and upper surface of belt wheel

8) Distribution radius of mounting hole

9) Distribution angle of mounting hole

10) Aluminum beam width

11) Hole spacing at the beginning of line segment

12) Hole spacing of straight line

13) Countersunk hole perforation diameter

14) Countersunk hole diameter

15) Countersunk hole depth

16) Hole spacing

17) Approximate weight for module length X = 1 m (without carriages)

18) Weight for additional length

19) Length of module in X direction. Length is the distance between the rail centres, see page 30 for details and calculation method

# CIRCULAR SYSTEMS

## CARRIAGE T4R

# 4.3

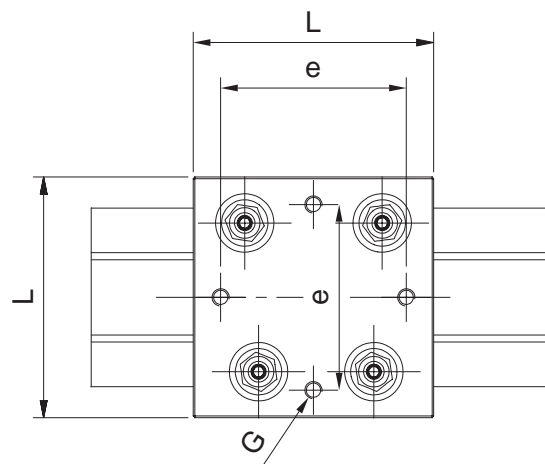
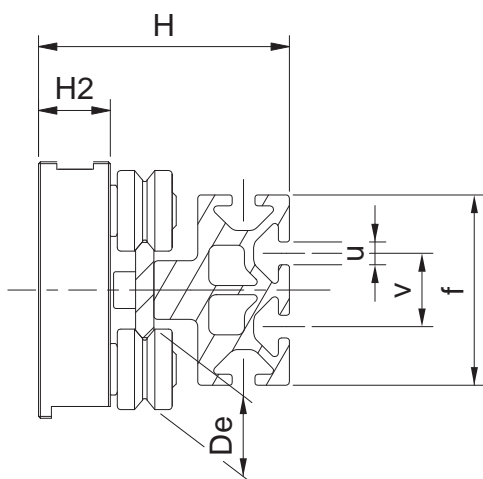

Type	L mm	D <sub>e</sub> mm	e mm	G	H mm	H <sub>2</sub> mm	U	V	f	Weight <sup>1)</sup> kg	Combinations
T4R 75 FR22EU-...	70	22	54	M5	68,5	19,6	6,2	20	52	0,40	AXNR 75
T4R 125 FR22EU-...	70	22	54	M5	68,5	19,6	6,2	20	52	0,40	AXNR 125
T4R 175 FR22EU-...	70	22	54	M5	68,5	19,6	6,2	20	52	0,40	AXNR 175
T4R 225 FR32EU-...	110	32	90	M8	83	27,4	6,2	40	80	1,22	AXNR 225
T4R 300 FR32EU-...	110	32	90	M8	83	27,4	6,2	40	80	1,22	AXNR 300
T4R 400 FR40EU-...	150	40	126	M10	102	29,5	6,2	2x30	120	2,50	AXNR 400
T4R 500 FR40EU-...	150	40	126	M10	102	29,5	6,2	2x30	120	2,50	AXNR 500

1) Weight without locating CAM

### CONNECTORS

Connector type A with Durbal tie rod is available for AXNR radius 125 175 225 300 mm.

Connector type B is available for all dimensions.

AXNR radius	Belt type	Carriage model	
		Connector type A	Connector type B
75	AT10-25		T4R75 FR22EU-B ...
125	AT10-25	T4R125 FR22EU-A ...	T4R125 FR22EU-B ...
175	AT10-25	T4R175 FR22EU-A ...	T4R175 FR22EU-B ...
225	AT10-32	T4R225 FR32EU-A ...	
	AT20-32		T4R225 FR32EU-B ...
300	AT10-32	T4R300 FR32EU-A ...	
	AT20-32		T4R300 FR32EU-B ...
400	AT20-50		T4R400 FR40EU-B ...
500	AT20-50		T4R500 FR40EU-B ...

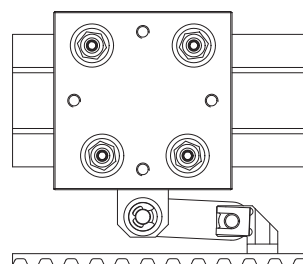

Connector type A

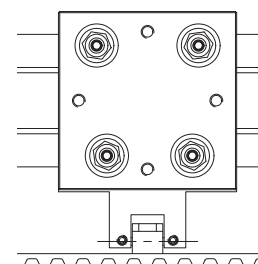

Connector type B

# CIRCULAR SYSTEMS

# LOAD, MOMENTS AND OPERATING TEMPERATURE

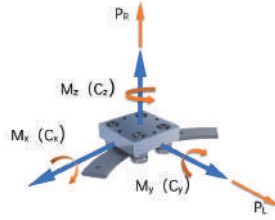

## MAXIMUM LOADS ON SINGLE CARRIAGE

The following table shows the maximum loads that can be applied on a single carriage.

Module	Carriage	F <sub>y</sub>	F <sub>z</sub>	M <sub>x</sub>	M <sub>y</sub>	M <sub>z</sub>
AXNR.. 75	T4R75FR22EU-...	2800	1680	18	26	48
AXNR.. 125	T4R125FR22EU-...	2800	1680	18	28	51
AXNR.. 175	T4R175FR22EU-...	2800	1680	18	30	53
AXNR.. 225	T4R225FR32EU-...	4000	3200	63	95	130
AXNR.. 300	T4R300FR32EU-...	4000	3200	63	100	130
AXNR.. 400	T4R400FR40EU-...	7300	5600	190	250	350
AXNR.. 500	T4R500FR40EU-...	7300	5600	190	250	350

The maximum loads are based on the stud and bearing strengths. The loads in the table are considered as acting singularly. For applications with many loads acting at the same time the loads must be reduced.

## BASIC DYNAMIC LOADS OF SINGLE CARRIAGE

The following table shows the nominal loads that correspond to a nominal life of the bearing at 100 km. The nominal lifetime of the carriage can be estimated from the standard bearing formula

$$L_{10} = (C_i / P_i)^3 \times 100 \text{ km}$$

C<sub>i</sub> is the basic dynamic load capacity in a specific direction i and P<sub>i</sub> is the external load applied in the same specific direction.

Module	Carriage	F <sub>y</sub>	F <sub>z</sub>	M <sub>x</sub>	M <sub>y</sub>	M <sub>z</sub>
AXNR.. 75	T4R75FR22EU-...	5800	4000	43	62	100
AXNR.. 125	T4R125FR22EU-...	5800	4000	43	67	105
AXNR.. 175	T4R175FR22EU-...	5800	4000	43	72	110
AXNR.. 225	T4R225FR32EU-...	11600	8500	165	250	375
AXNR.. 300	T4R300FR32EU-...	11600	8500	165	260	375
AXNR.. 400	T4R400FR40EU-...	17000	12000	400	550	800
AXNR.. 500	T4R500FR40EU-...	17000	12000	400	550	800

C<sub>i</sub> is the basic dynamic load capacity in a specific direction i and P<sub>i</sub> is the external load applied in the same specific direction.

## CALCULATION EXAMPLE: CARRIAGE LOADED WITH AN EXTERNAL LOAD F

Carriage T4R225 FR32EU-A-00  
F = 2000 N

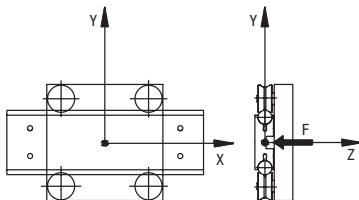

The external load F acts in the z-axis direction: P<sub>z</sub> = F = 2000

In the table of the “maximum loads” you find that the load capacity F<sub>z</sub> for carriage T4R225 FR32EU is equal to 3200, so the system is validated against breakage. To estimate the system lifetime we proceed as follows: from the table of the “basic dynamic loads” we see that C<sub>z</sub>, for the carriage T4R225 FR32EU, is equal to 8500.

The nominal lifetime will be:

$$L_{10} = (8500 / 2000)^3 \times 100 = 7676 \text{ Km}$$

The admissible load on the system depends on guide rollers load capacity and on the retention force of the connector between carriage and belt.

The tables in this page allow the selection of AXNR module size, based on guide roller load capacity, speed and accelerations involved. The belt transmission, in fact, is subject to inertia forces due to the duty cycle and due to the centrifugal acceleration between the straight and curved path.

This second acceleration becomes consistent when increasing the velocity and usually defines the max admissible speed of the carriage. For a system mounted in horizontal plane and with the payload mass centred on the carriage with connector B type the graph here below allows a preliminary evaluation.

Moreover, mass position on the carriage and module orientation strongly affect the load on the belt.

Contact our Technical Service to better evaluate your load conditions. See page 30 and Application Form for the data to be used for the dimensional verifying.

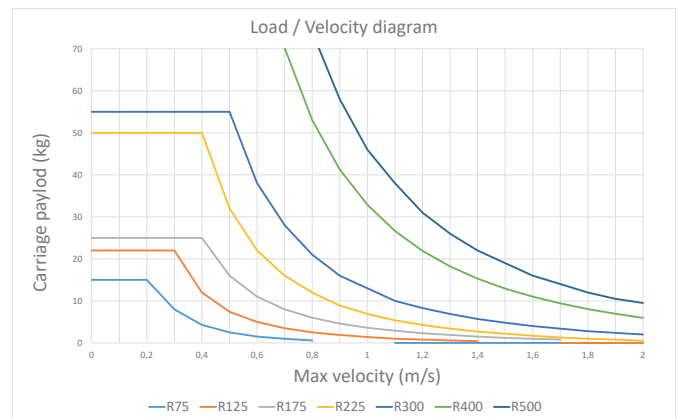

## OPERATING TEMPERATURE

The standard operating temperature is between -10°C and +70°C. Out of this range, please contact the Nadella technical support.

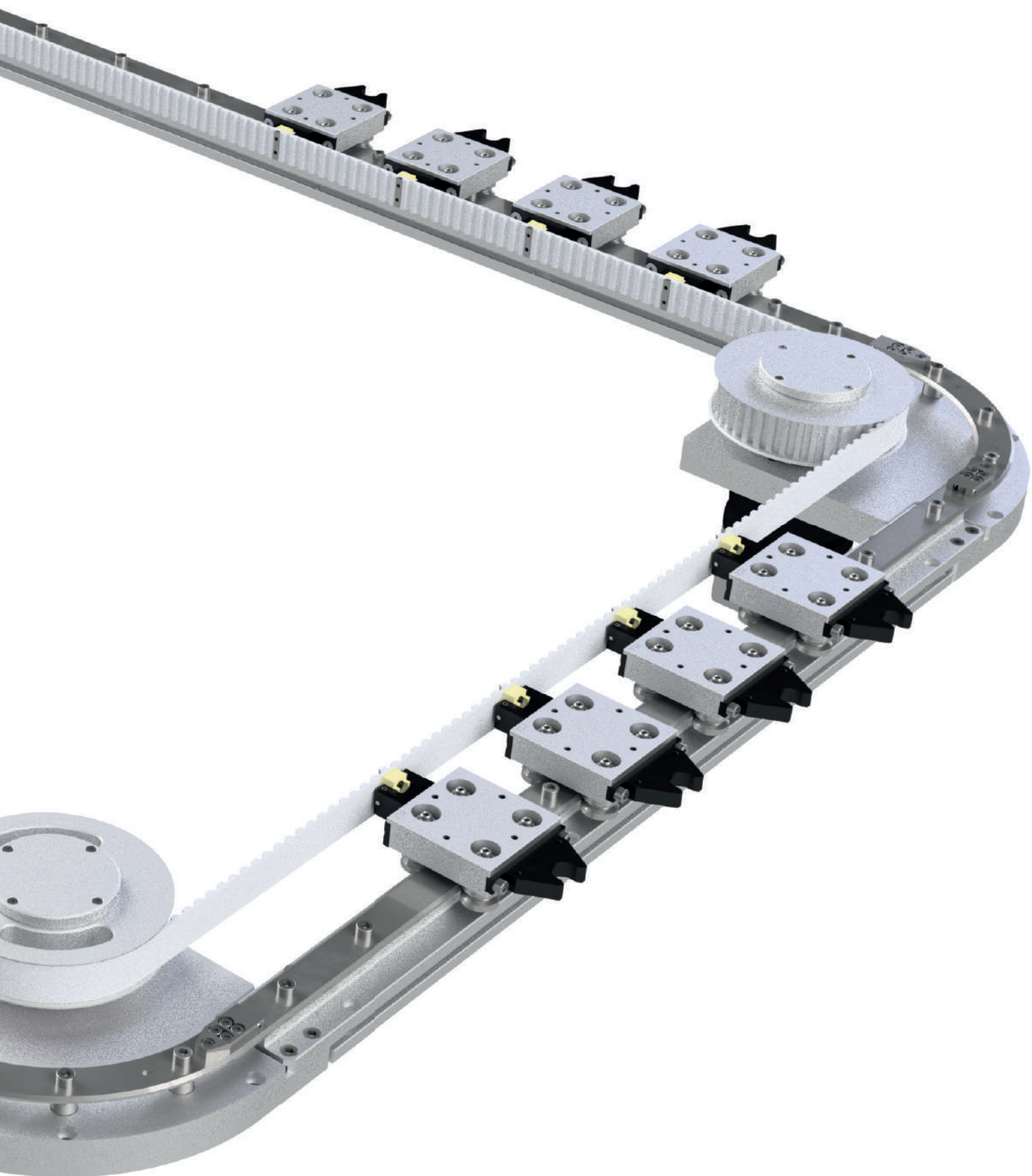

# TECHNICAL FEATURES



**PAGE 26**

## **5.1 DRIVE CONNECTIONS AND POSITIONING**

- Direct gearbox connection
- Positioning system
- Transverse reinforcements

**PAGE 30**

## **5.2 CIRCULAR SYSTEM DEFINITION ELEMENTS**

**PAGE 31**

## **5.3 APPLICATION FORM**

**PAGE 32**

## **5.4 APPLICATION EXAMPLES**

- Test line
- Bottling line
- Battery assembly line
- High speed conveyor

**PAGE 36**

## **5.5 SPARE PARTS**

**PAGE 37**

## **5.6 ORDER CODES**

- AXNR System
- Carriage

# TECHNICAL FEATURES

## DRIVE CONNECTIONS AND POSITIONING

### DIRECT GEARBOX CONNECTION



The gearbox is directly connected to the aluminium alloy base of AXNR Circular System.

Planetary gearbox with reinforced bearings are used to support the belt tension and to allow precise movement.

Depending on the available space it is possible to select the axial gearbox or the 90° angle gearbox. Gearbox is complete of flange and finished accordingly with the motor type used by the customer.

In most cases a two stages gearbox is selected to achieve the right balancing between speed and torque.

The table here below shows approximate dimensions and available ratios for the two stages gearbox.

Precise dimension can be defined with the specific motor flange type identification.

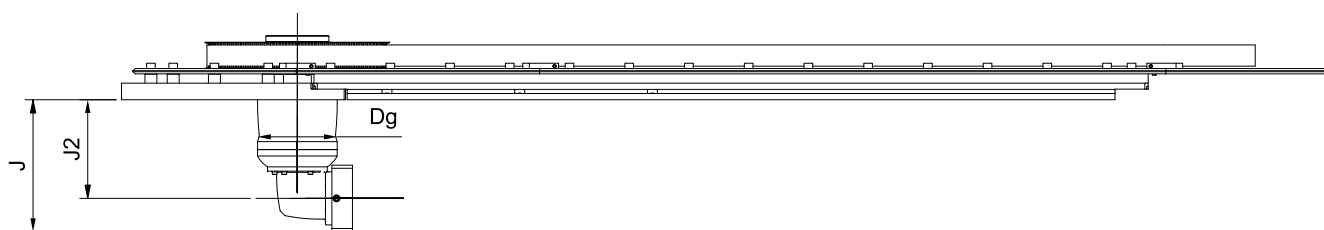
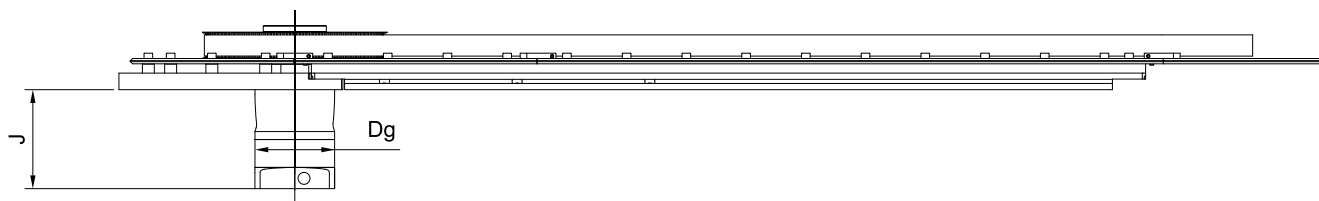

Type	Gear box body size Dg	Axial version J	Angle version J2/J	Available gear box ratio
AXNRO / AXNRQ 75	50	70	57 / 77	9-12-15-16-20-25-28-30-32-35-40-50-64-70-100
AXNRO / AXNRQ 125 AXNRO / AXNRQ 175	90	111	99 / 140	9-12-15-16-20-25-28-30-32-35-40-50-64-70-100
AXNRO / AXNRQ 225 AXNRO / AXNRQ 300	120	142	139 / 197	9-12-15-16-20-25-28-30-32-35-40-50-64-70-100
AXNRO / AXNRQ 400 AXNRO / AXNRQ 500	155	172	178 / 253	20-25-32-40-50-60-64-100

## POSITIONING SYSTEM

AXNR positioning system has been developed especially for precise circular applications. The system is driven by an air cylinder located below the straight module beam. The cylinder rotates the indexer shaft equipped with cam followers that engage in the locating cam fixed on the carriages. The system allows repeatability in the carriage location of  $\pm 0.05$  mm. One or several positioning systems can be mounted on the module to index all carriages or some carriages only.

**BEFORE**

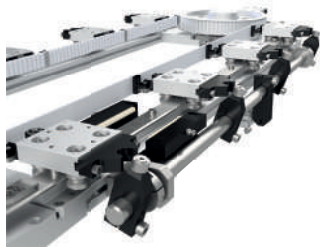

Avoid the moving carriage

**AFTER**

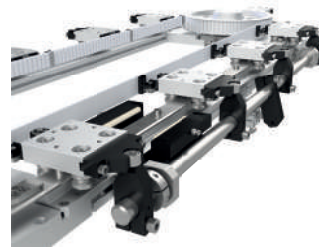

Automatic positioning system

When the positioning system is used carriages are equipped with locating cam.

Locating cam

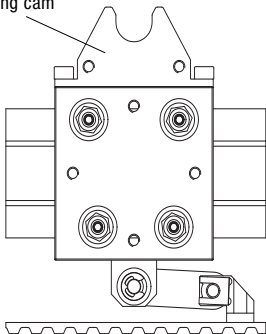

Positioning system is driven by pneumatic cylinder. Consider there is a space below the system and beside the carriages required for the air cylinder.

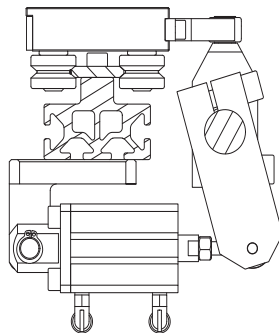

One cylinder is used to activate several positioning cam follower. Normal maximum length for a single unit up to 2000 mm.

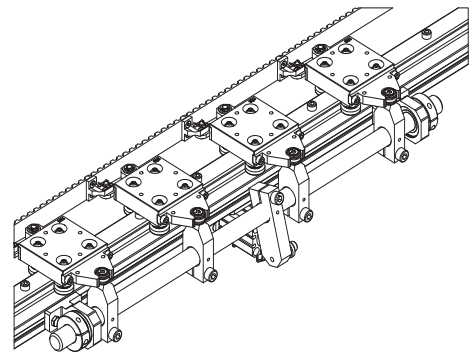

## TRANSVERSE REINFORCEMENT

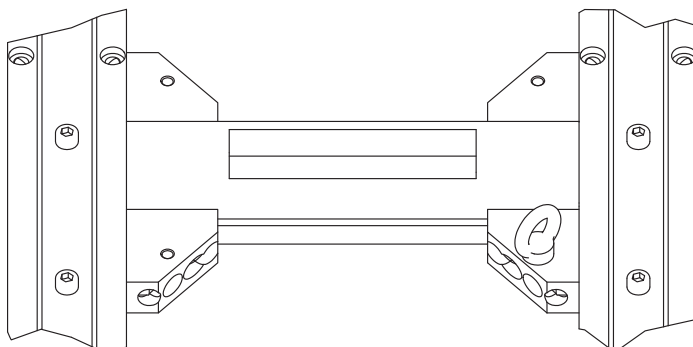

In case of long or heavy modules these can be provided with transversal supports (Option 14).

The supports are linked to the structure with angular connectors equipped with threaded holes to accommodate eyebolts.

# TECHNICAL FEATURES

## DRIVE CONNECTIONS AND POSITIONING

### INDUCTIVE PROXIMITY SENSORS KIT

In case a reference point is required, inductive proximity sensors can be used. The sensor can be easily fixed on the aluminium profile and reads a ferromagnetic target positioned on the carriage cam.

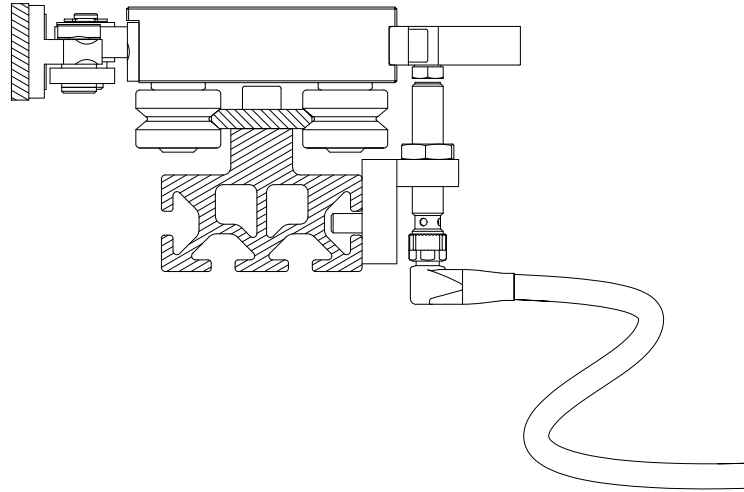

Kit	AXNR size	Sensor	Connected voltage	Max load current	Switching precision	Cable length	Protection class
20.036.610	22	Switch i4 PNP-NO (Normally Open)	10 ... 30 V DC	200 mA	≤ 10% of sensing distance	5m	IP 67
20.036.620	22	Switch i4 PNP-NC (Normally Close)					
20.055.610	35	Switch i4 PNP-NO (Normally Open)					
20.055.620	35	Switch i4 PNP-NC (Normally Close)					

Each kit is composed by one sensor, with its cable and its holder and one ferromagnetic target.

## NOTE

A large grid of graph paper, consisting of 20 columns and 30 rows of small squares, intended for taking notes.

# TECHNICAL FEATURES

## CIRCULAR SYSTEM DEFINITION ELEMENTS

# 5.2

For the definition of the AXNR system proceed as follows:

1. Define the application requirement: weight and dimension of the mass to be handled, additional forces acting on the carriage, expected system life, module orientation in the space, environment condition as cleanness, temperature, cycle details as stroke, acceleration, velocity, cycle time.
2. Select the carriage dimension accordingly with the load and carriage load capability. Data in the tables allow calculation in simple cases, refer to Nadella service for assistance.
3. Decide which configuration is desired (AXNO or AXNRQ) and how many carriages are needed.
4. Estimate the module dimensions as follows. The dimensions depend on the belt length. In most cases the carriages are at constant pitch and the belt length is calculated as the number of carriages by the carriage distance (carriage distance has to be multiple of the belt pitch). From the belt length deduct the length of belt around pulleys (the belt pitch by the number of teeth of the full pulley Z). The result is the length of the belt parallel to the straight path. Divide this value by 2. For AXNRQ this result is a first approximation of the module Length X. For AXNRQ decide the desired width dimension Y and deduct it. The X length here calculated is a theoretical length, actual system length X has to be increased of few mm to compensate the elongation of the belt during the assembly (needed elongation is defined by Nadella during the product definition phase).
5. Choose gearbox type, lubricator position, carriage positioning system and other options. For AXNRQ modules define in which corner the drive pulley has to be located.
6. Fill in the application form and submit it to Nadella. It will simplify the technical evaluation and offering process.

# AXNR APPLICATION FORM

# 5.3

## AXNR Application Form

Company	
Contact person	
Phone	
email	
date	
Project designation	

## Application Data

Equipment type / Application description	
AXNR type (AXNR0 or AXNRQ)	
AXNR radius (75, 125, 175...)	
AXNRQ Width Y (useless value for AXNR0)	
Mark the drive pulley position	
System orientation [Horizontal, Lateral, Vertical]	
Number of carriages	
Distance between carriages [mm]	
Mass M applied on the carriage [kg]	
Mass position [mm]	<p>X=</p> <p>Y =</p> <p>Z =</p>
Additional force F acting on the carriage	<p>Fx=</p> <p>Fy =</p> <p>FZ =</p>
Additional force position	<p>X=</p> <p>Y =</p> <p>Z =</p>
Complete Cycle time [s]	
Stroke time (time to move from one position to the next one) [s]	
Acceleration [m/s <sup>2</sup> ]	
Max velocity [m/s]	
Carriage locating system [Yes / No]	
Number of positions with carriage locating system	
Gear box type [Axial / 90° angle]	
Gear box ratio 1:...	
Other requirements (corrosion resistance, temperature range, ...)	

## TECHNICAL FEATURES APPLICATION EXAMPLES

### TEST LINE

This high efficiency space-saving test line is possible due to the combination of the AXNRO Circular System and AXN actuators, which provides an automatic unmanned solution on every process.

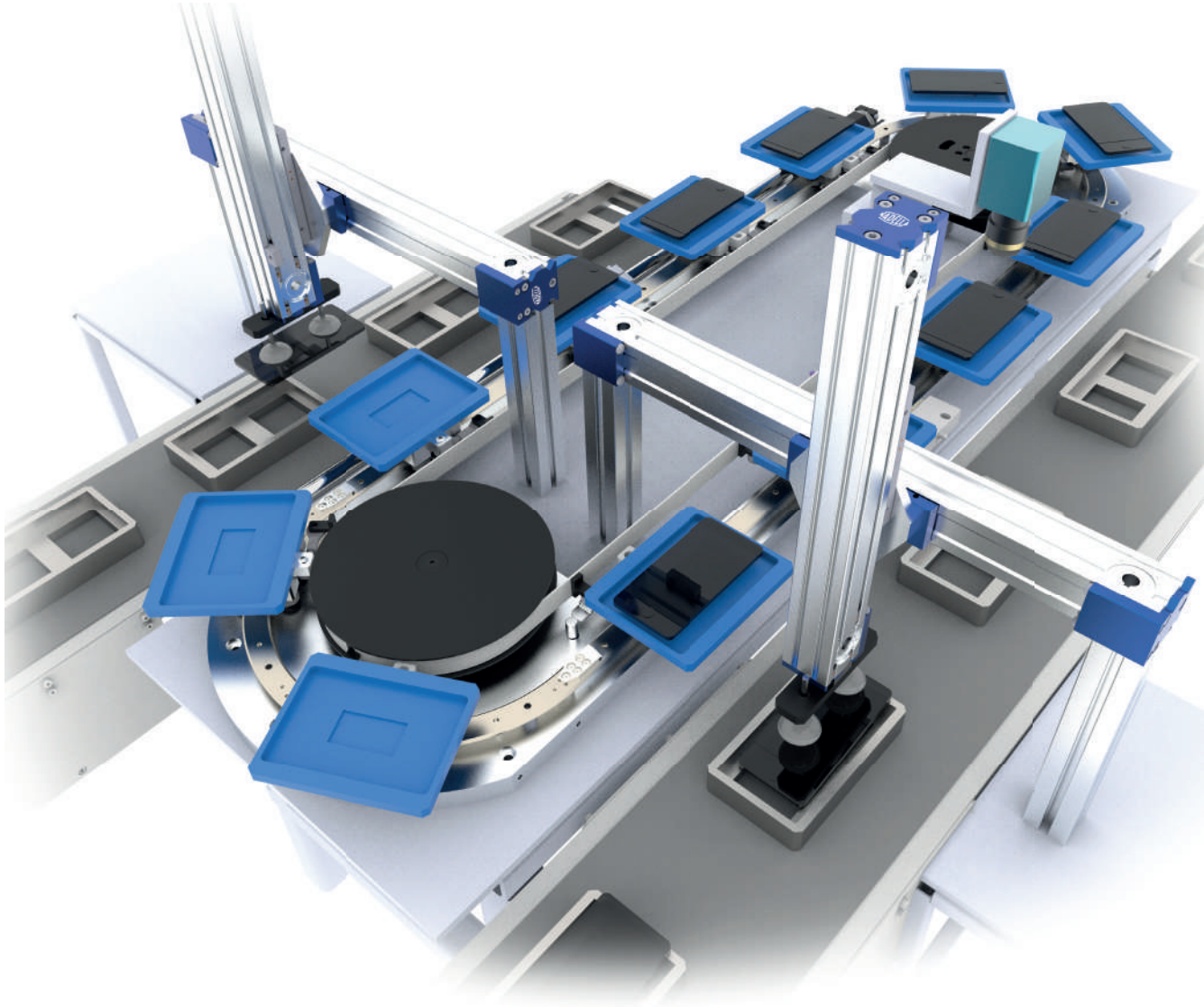

### BOTTLING LINE

Bottling line consists of both AXNRQ Circular System and AXN actuators for bottling, sealing, testing, marking and packaging processes. This line provides a space-saving automatic solution with high consistency.



## TECHNICAL FEATURES APPLICATION EXAMPLES

### BATTERY ASSEMBLY LINE

Battery assembly line consists of a big radius AXNRO Circular System paired with articulated robots. The high quality of Nadella rollers guarantees remarkable load capacity and long service time.

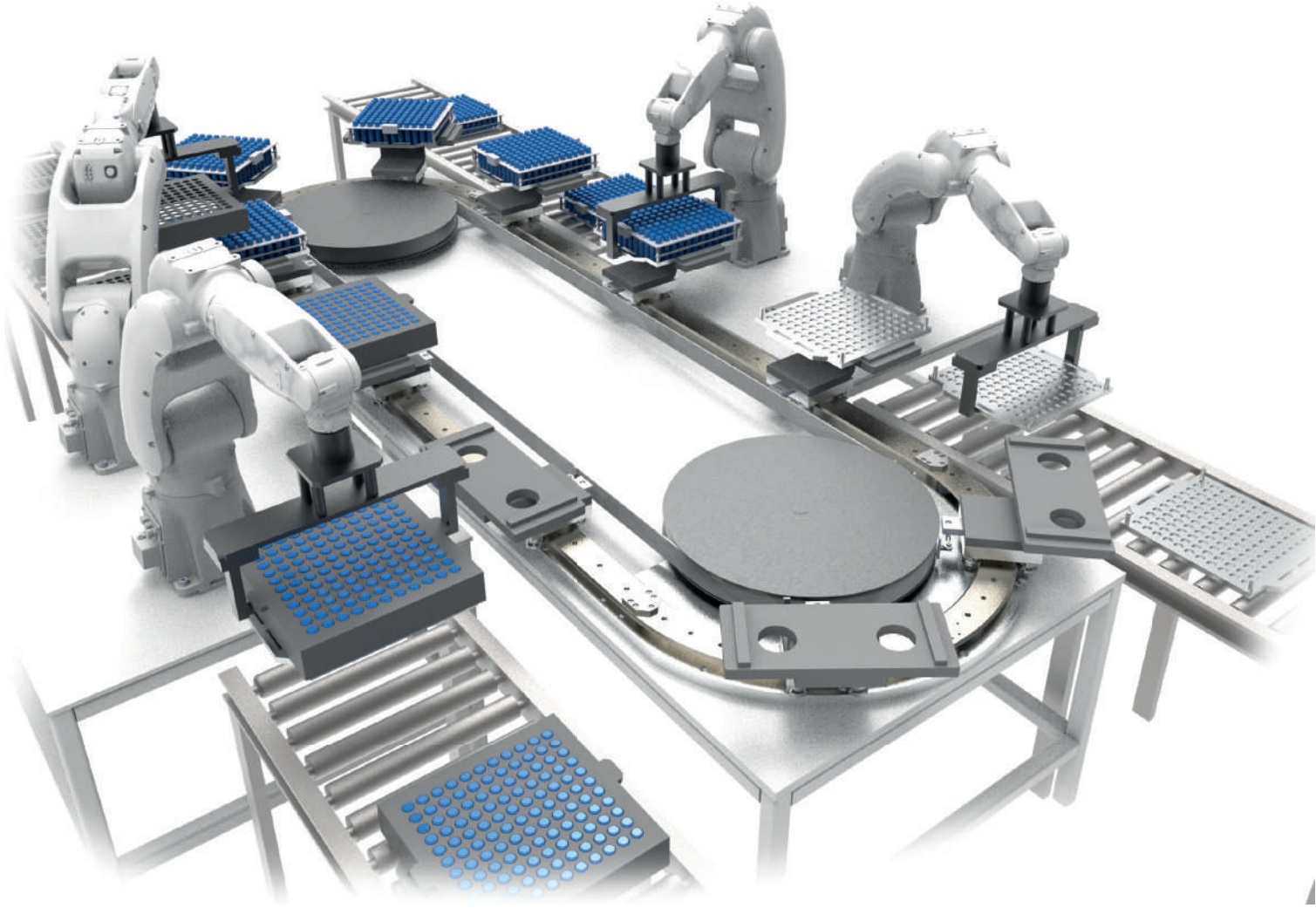

## TECHNICAL FEATURES APPLICATIONS EXAMPLES

### High Speed Conveyor

Two AXNRO Circular Systems can be positioned parallel to each other to serve as a double row conveyor, developed specifically for high speed and precision positioning. All floating rollers on one side provide self alignment, which eases the parallelism tolerance of the two bases during mounting and results in a steady conveyor system.

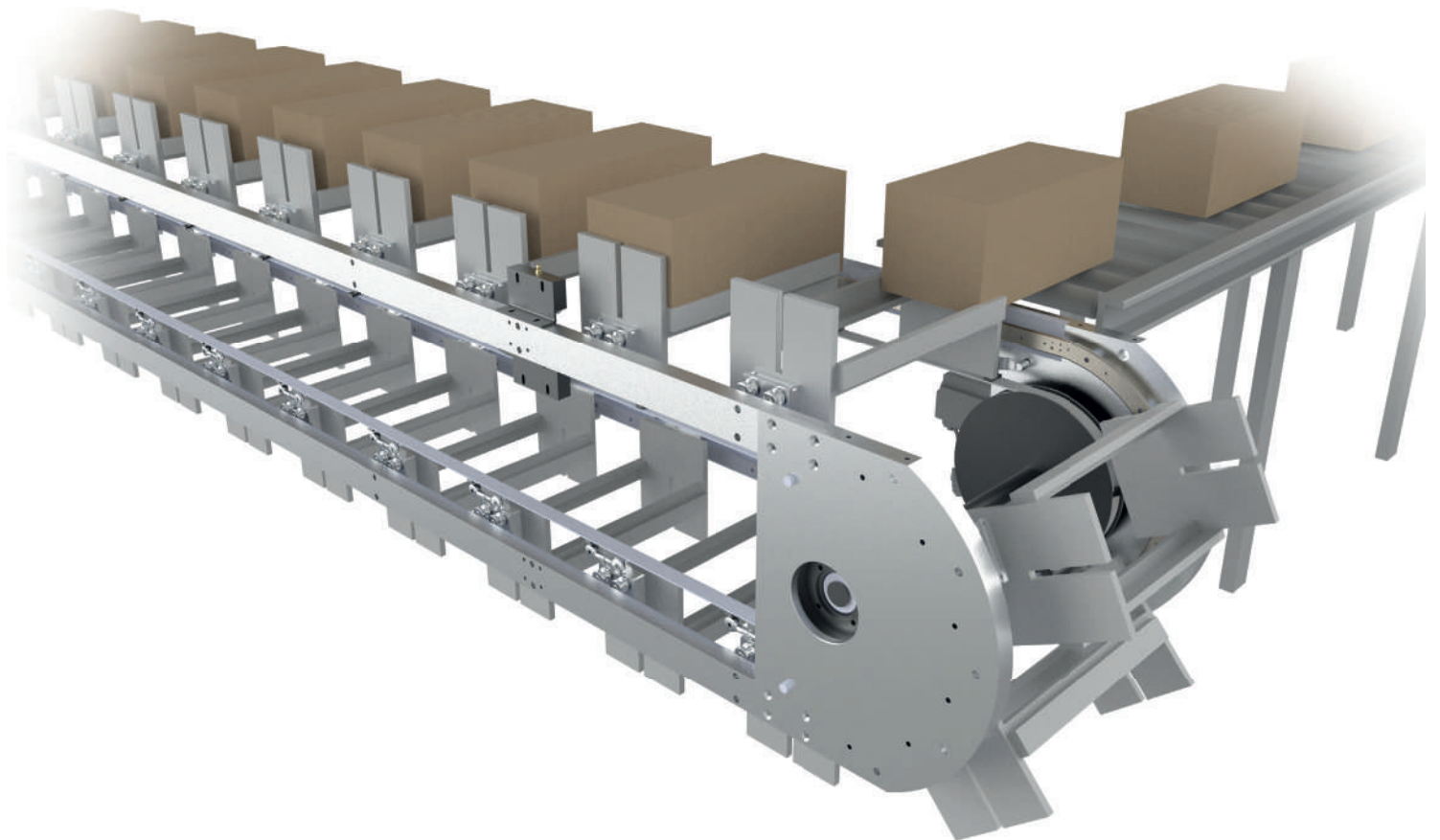

# TECHNICAL FEATURES

## SPARE PARTS

# 5.5

## SPARE PARTS

AXNR system is designed to work for a long time. Anyway some parts are subject to wear and spare parts can be ordered to prevent equipment downtime. When ordering spare parts for already existing modules please provide the serial number printed on the unit.

Spare part list (in bold suggested):

- **Belt (false teeth included)**
- **Lubricator felts**
- Belt and pulleys
- Complete carriage (see carriage ordering code)
- Connection between carriage and belt
- Carriage locating cam
- Positioning system cam follower
- Positioning system air cylinder
- Complete positioning system unit
- Guide rollers (concentric and eccentric)
- Gearbox
- Home sensor
- Home sensor with fitting

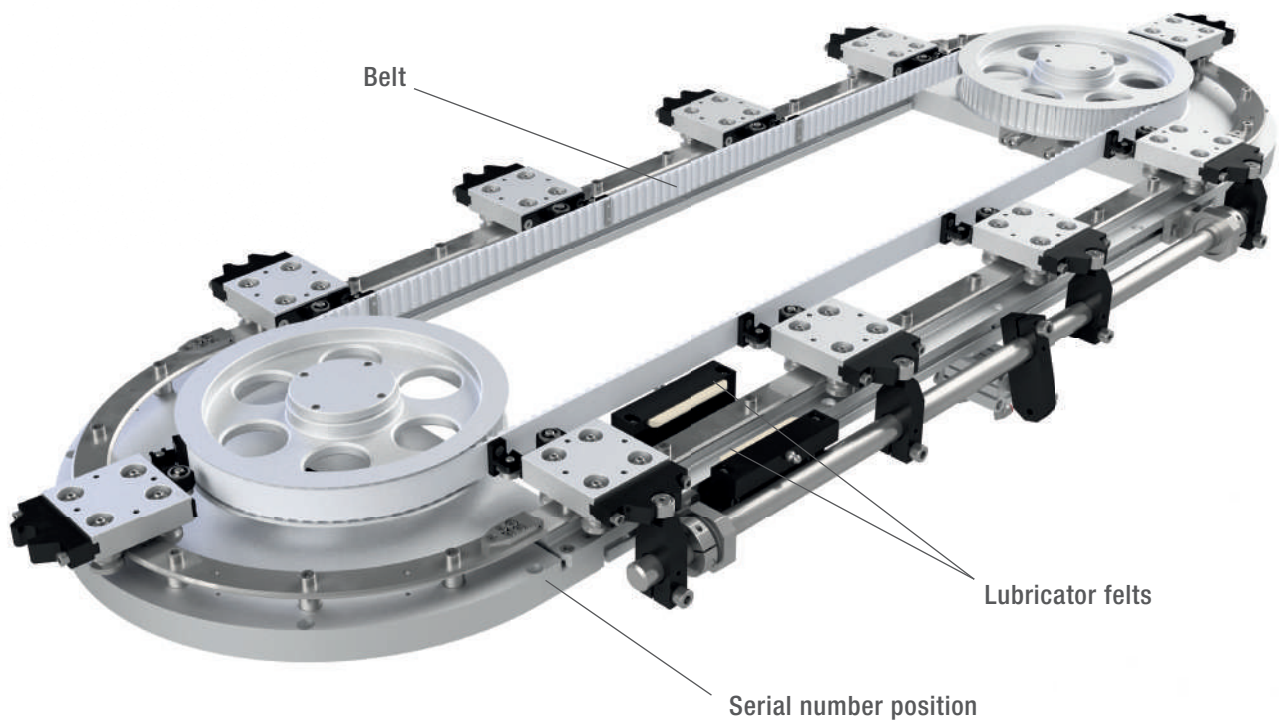

# TECHNICAL FEATURES ORDER CODES

## AXNR SYSTEM

### ORDER CODE

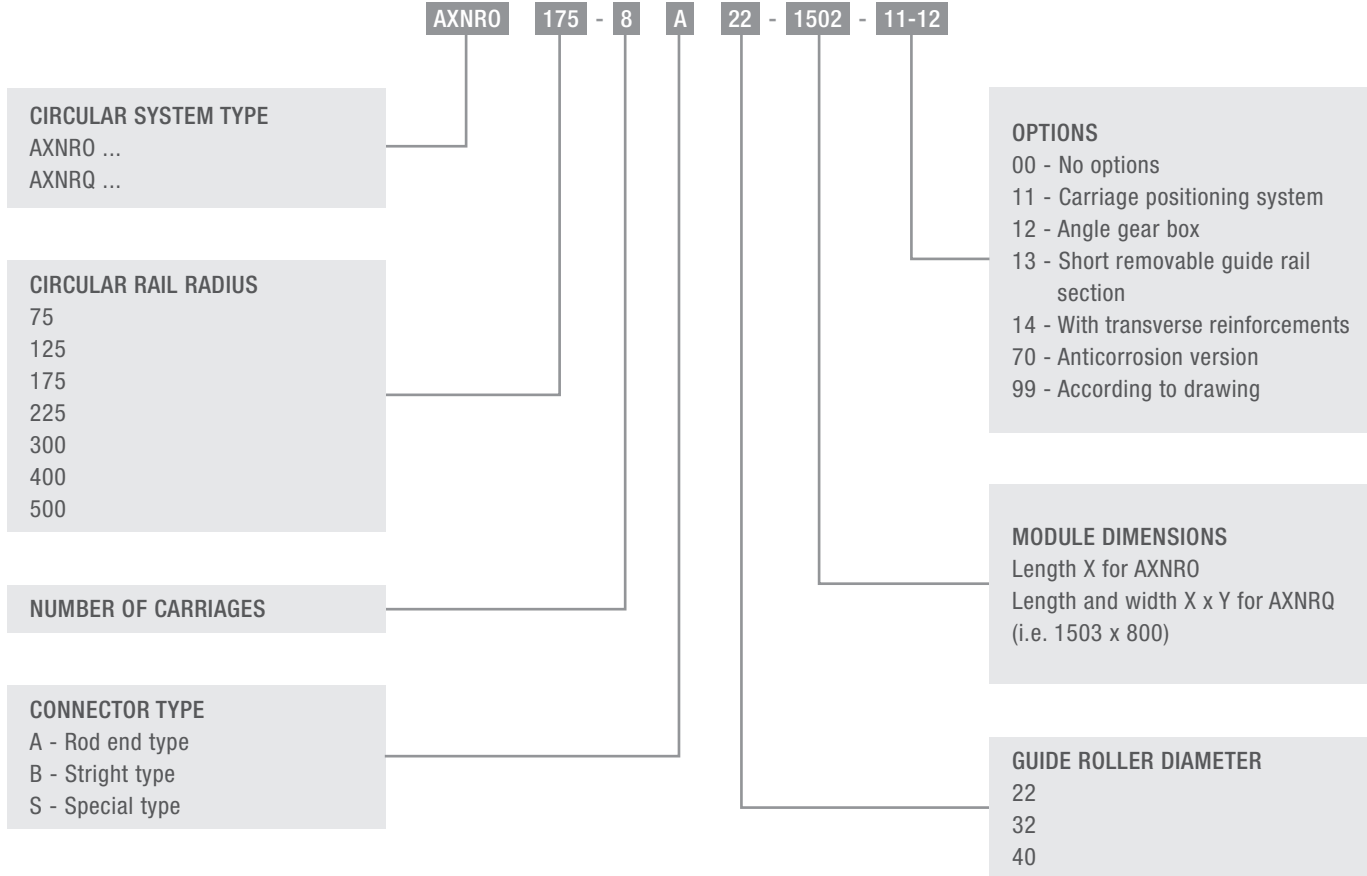

## CARRIAGE

### ORDER CODE

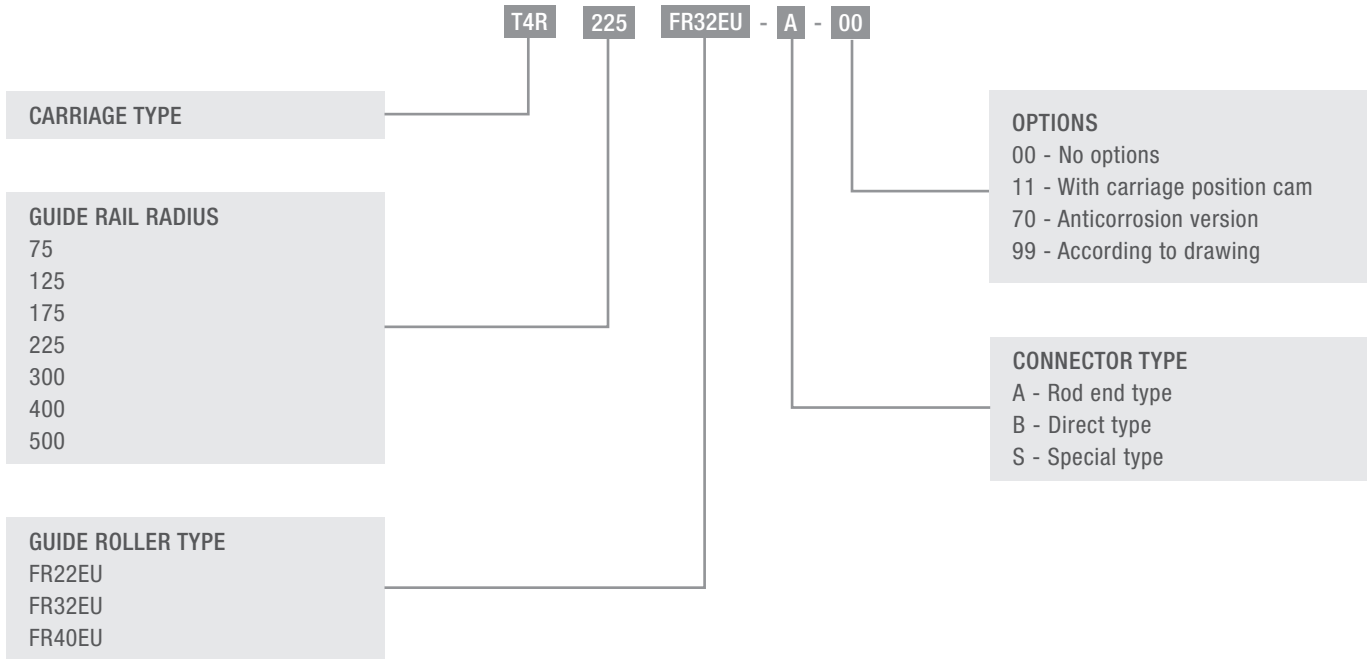

# NOTE

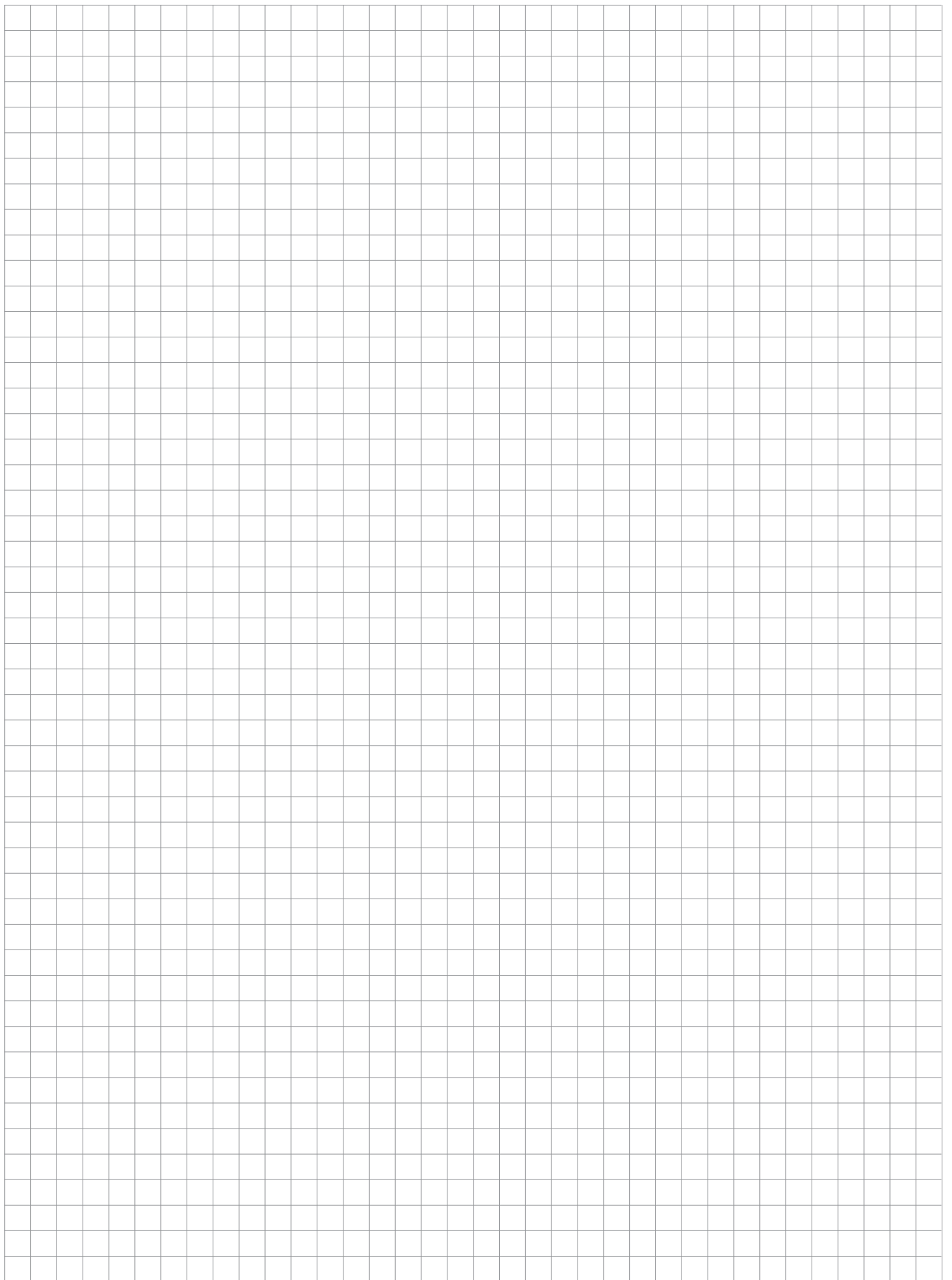





**NADELLA** / [nadella.com](http://nadella.com)

**DURBAL** / [durbal.com](http://durbal.com)

**CHIAVETTE UNIFICATE** / [chiavette.com](http://chiavette.com)

**IPIRANGA** / [ipirangahusillos.com](http://ipirangahusillos.com)

**SHUTON** / [shuton.com](http://shuton.com)

**THE SPECIALIST FOR MOTION TECHNOLOGY**

**AXNR221EN**

Version 02/2022 · Nadella Group | [nadella.com](http://nadella.com) | Errors and omissions excepted.